

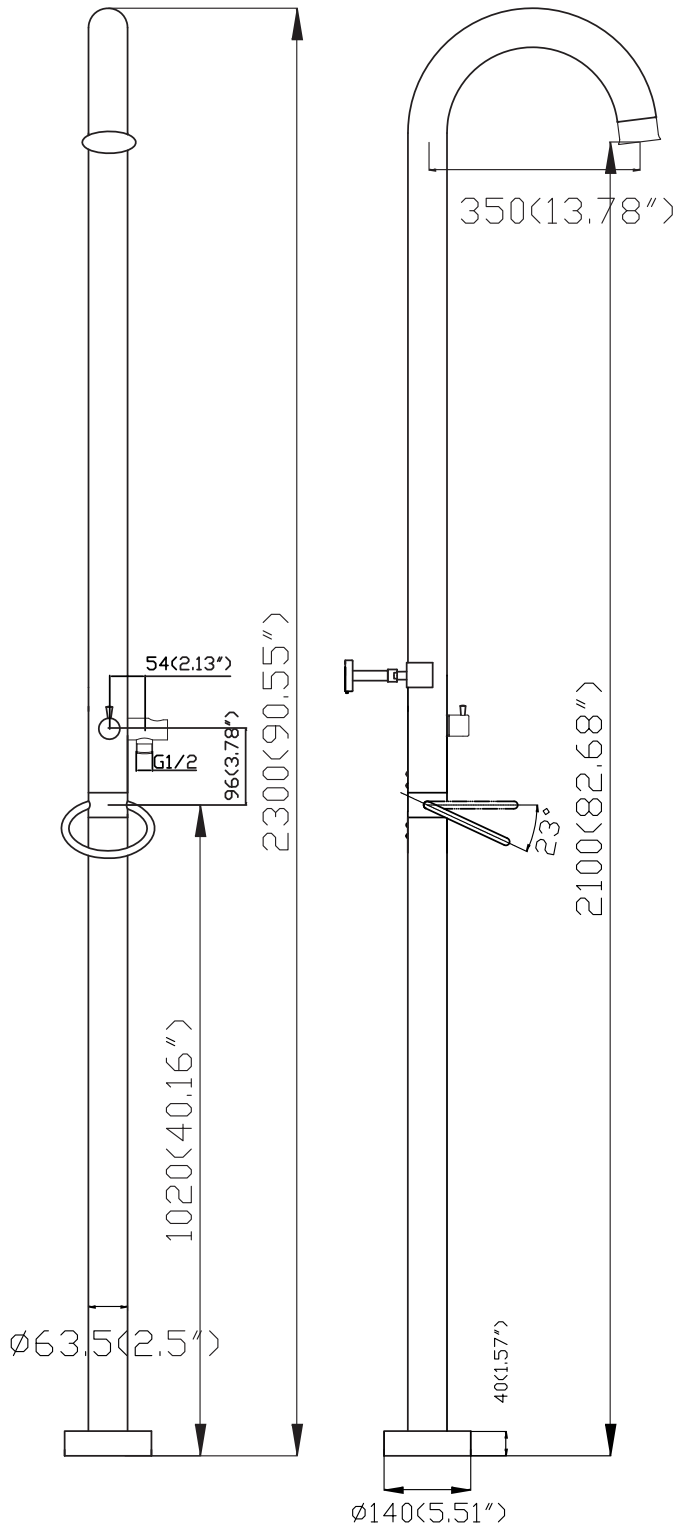

## JEE-O original 02



Article code:  
 400-6400 (original-02-brushed)  
 400-6480 (original-02-polished)  
 Cartridge: Sedal mixer  
 Material: Stainless Steel r304  
 Connection: nylon<sup>(out)</sup>/epdm<sup>(in)</sup>  
 flexhose with brass swivel  
 Length of flexhose 150 cm  
 Flow at water of 38°C /100.4°F  
 12l / 3,2gal p/m at 3bar pressure  
 Dimension package:  
 L 158 x W 18 W 54 x H 21 cm  
 L 62,2 x W 7,1 W 21,3 x H 8,3"  
 Weight: 13.2 kg / 29.10 lbs  
 Package weight: 2,0kg /4.40lbs  
 Placing on a water-tight floor  
 2 year warranty  
 HS code: 84818011900

Note: UV radiation and extreme temperature can affect the color and structure of the JEE-O original surface.

[www.jee-o.com](http://www.jee-o.com)

