

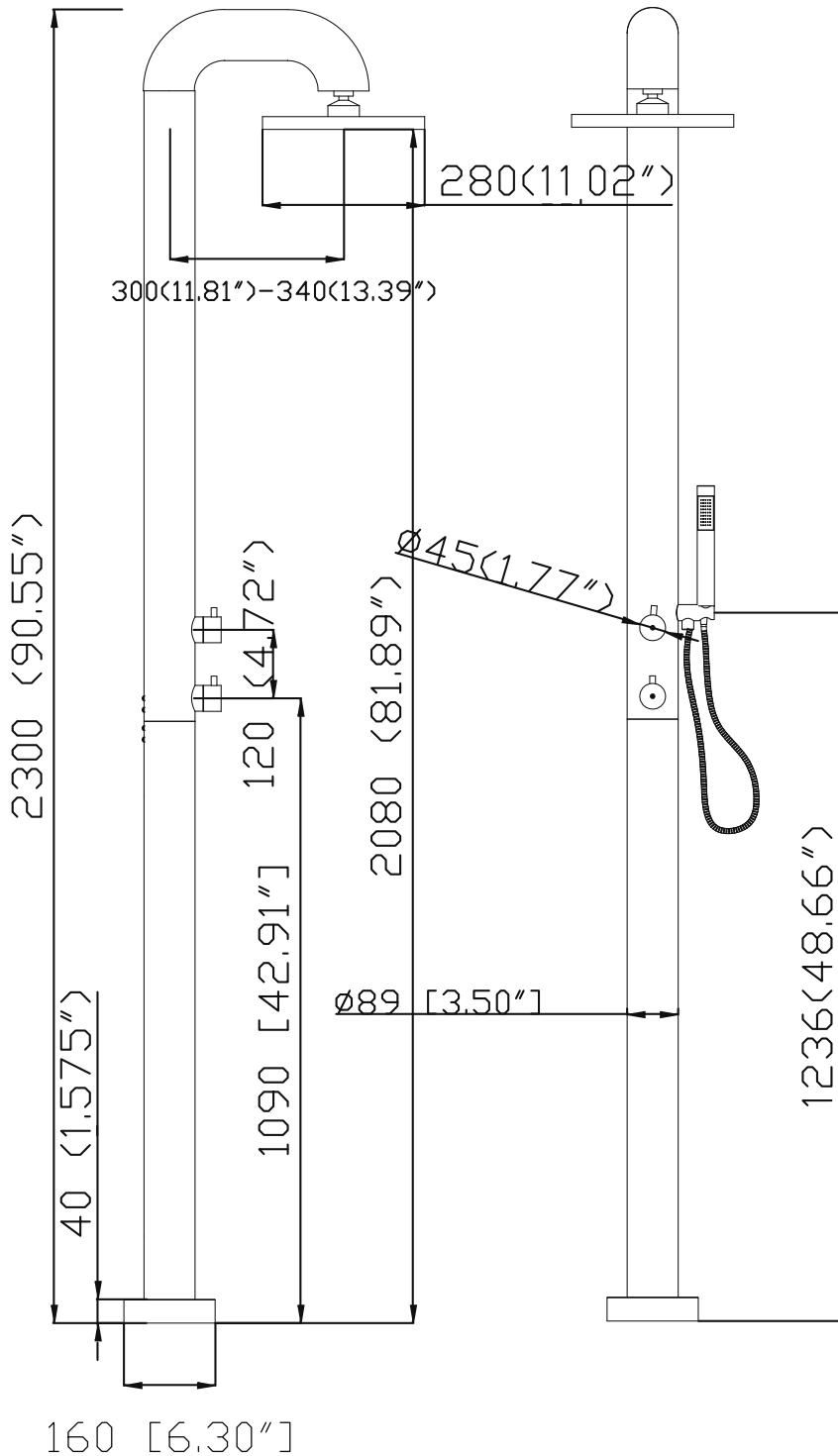

## JEE-O fatline 02TH



Article code:

400-6490 (fatline-02TH-brushed)

400-6495 (fatline-02TH-polished)

Cartridge: Cedal / normal

Material: Stainless Steel r304

Connection: nylon<sup>(out)</sup>/epdm<sup>(in)</sup>

flexhose with brass swivel

Length of flexhose 150cm

Flow at water of 38°C / 100.4°F

10l / 2.6 p/m at 3bar pressure

Dimension package:

L 158 x W 18 W 54 x H 21 cm

L 62,2 x W 7,1 W 21,3 x H 8,3"

Weight: 18 kg / 39.60lbs

Package weight: 2,0kg / 4.40lbs

Placing on a water-tight floor

2 year warranty

HS code: 84818011900

Note: UV radiation and extreme temperature can affect the color and structure of the JEE-O fatline surface.

[www.jee-o.com](http://www.jee-o.com)

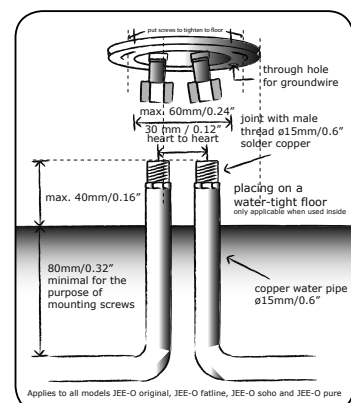

Applies to all models JEE-O original, JEE-O fatline, JEE-O soho and JEE-O pure

