

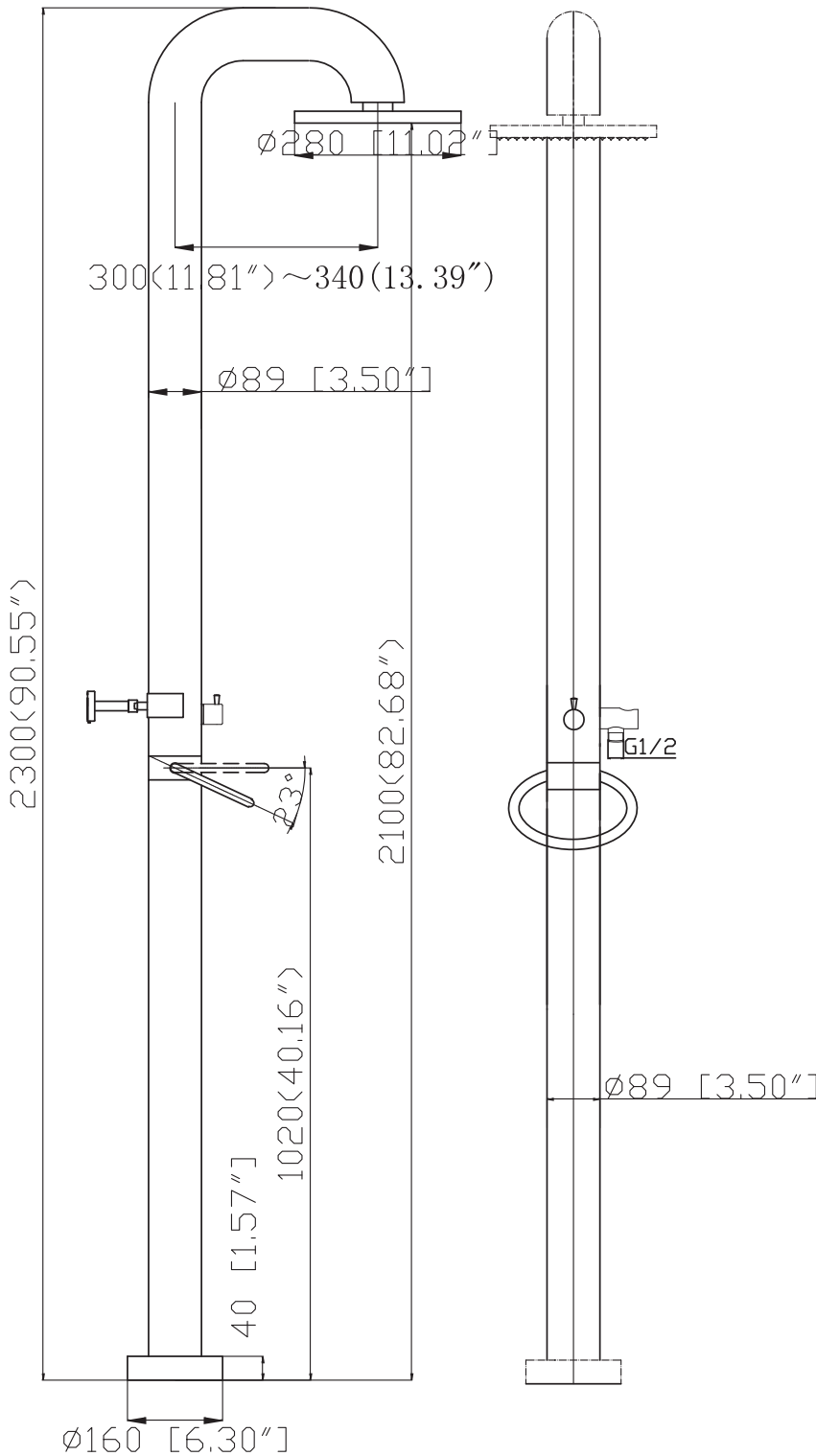

JEE-O fatline 02

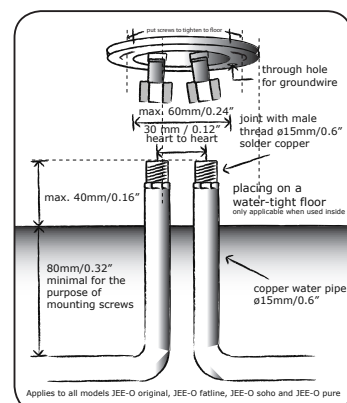

Article code:
 400-6460 (fatline-02-brushed)
 400-6465 (fatline-02-polished)
 Cartridge: Sedal mixer
 Material: Stainless Steel r304
 Connection: nylon^(out)/epdm⁽ⁱⁿ⁾
 flexhose with brass swivel
 Length of flexhose 150 cm
 Flow at water of 38°C /100.4°F
 12l / 3.2gal p/m at 3bar presure
 Dimension package:
 L 158 x W 18 W 54 x H 21 cm
 L 62,2 x W 7,1 W 21,3 x H 8,3"
 Weight: 17.6 kg / 38,80 lbs
 Package weight: 2,0kg /4.40lbs
 Placing on a water-tight floor
 2 year warranty
 HS code: 84818011900



Note: UV radiation and extreme temperature can affect the color and structure of the JEE-O fatline surface.

www.jee-o.com