

PEARL BASIN MIXER

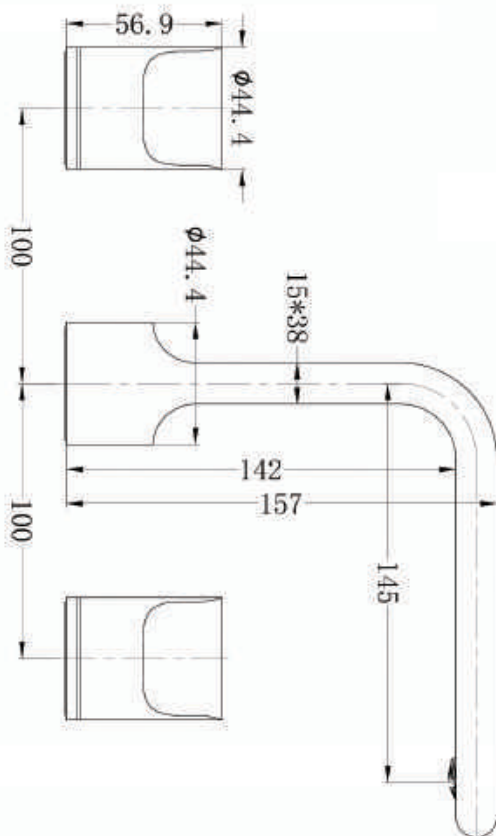

Dimensions are nominal measurements only.

SPECIFICATION

PRODUCT CODE	YSW2017-01
WELS RATING	6 STAR 4.5L/MIN
WATERMARK LICENSE	WM-060073
TEMPERATURE RATING	MIN 1°C-MAX 75°C
PRESSURE RATING	MIN 150KPa-MAX 500KPa

FINISH

NR201701CH	chrome
NR201701BRG	brushed rose gold
NR201701GM	gun metal

MAINTENANCE AND CARE

All surfaces should be cleaned with mild liquid detergent or soap and water.

Do not use cream cleaners or citrus based cleaning products, as they are abrasive.

Use of unsuitable cleaning agents may damage the surface. Any damage caused in this way will not be covered by warranty.

PACKAGING INCLUDES

- 1x spout set
- 2x body set
- 2x valve
- 1x allen key
- 1x mixing tube



Versions: 2019.12

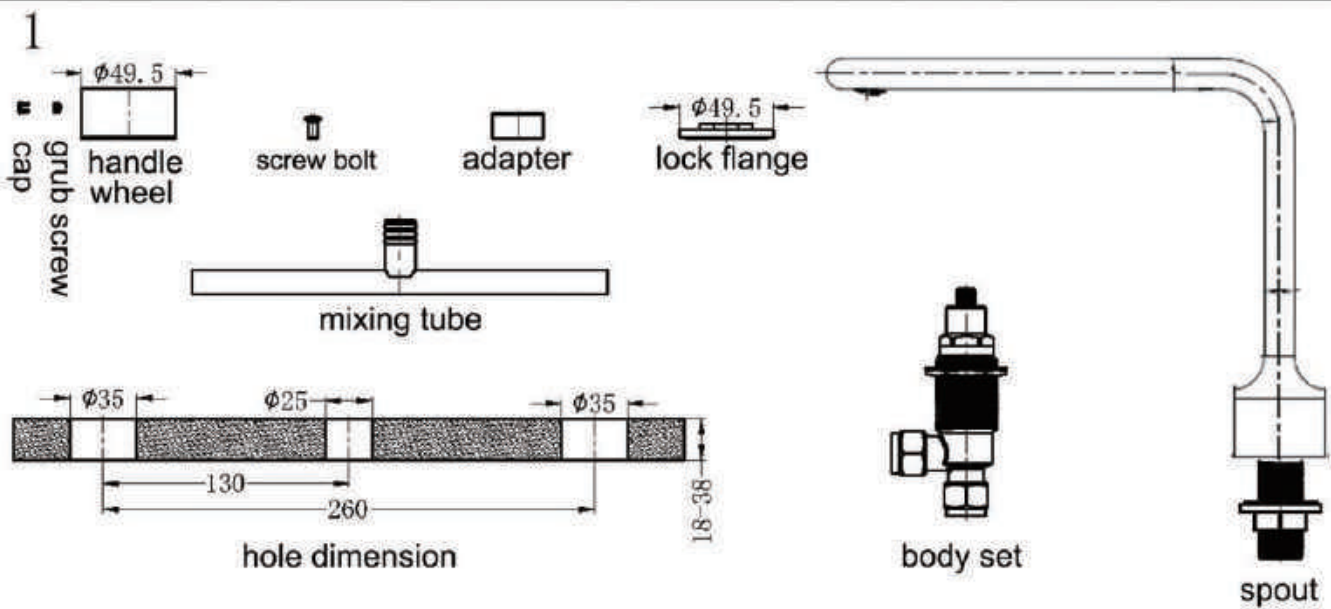

2

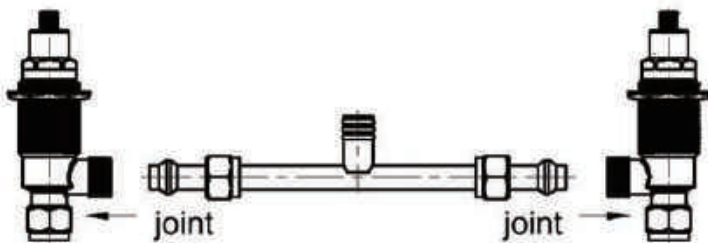

1. remove the joint from the body set.
2. put the hex nut and joint on the mixing tube in a row as the picture.
3. plug the joint into body set , and screw hex nut , don't too tight.

3

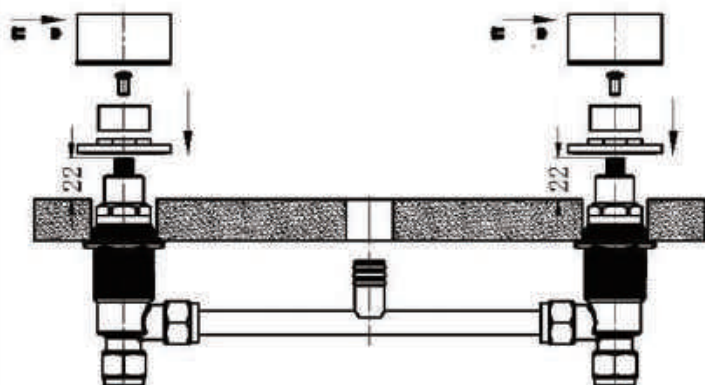

1. plug the assembled kit (picture 2) from the bottom side of the counter, and adjust the height as the picture.
2. put on lock flange, and tighten by wrench firmly.
3. put on adapter and lock by the screw bolt.
4. put handle wheel and lock the grub screw, then put on the cap.

4

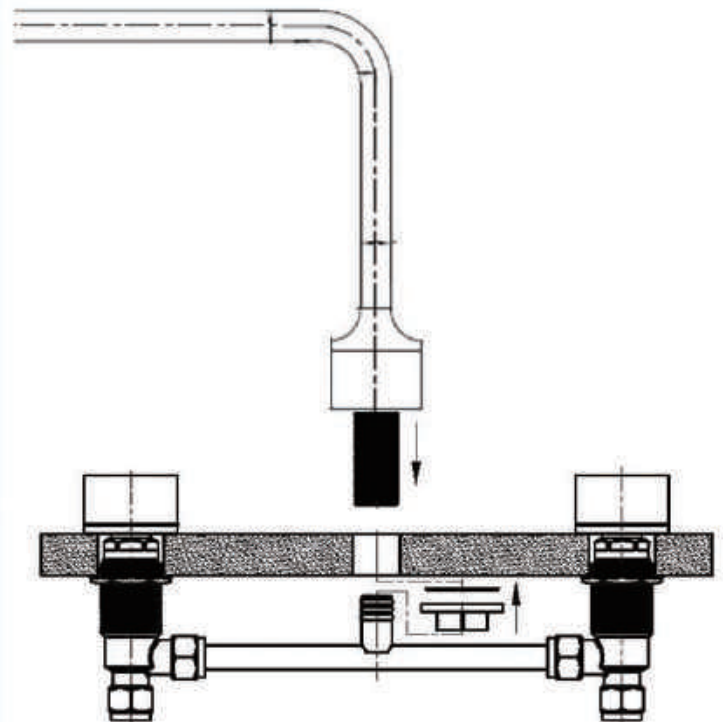

1. remove the hex nut and washer from the spout.
2. plug the spout in the hole on the counter and put on the washer and spout hex nut.
3. plug the bottom of the spout onto mixing tube.
4. tighten the spout hex nut.
5. tighten the hex nut beside the joint firmly by wrench.