





Kara Progressive Wall Basin Set

SPECIFICATION

PRODUCT CODE	YSW2719-07A
WELS RATING	5 STAR 6L/MIN
WATERMARK LICENSE	WM-060073
TEMPERATURE RATING	MIN 1°C-MAX 75°C
PRESSURE RATING	MIN 150KPa-MAX 500KPa



FINISH

	CHROME NR271907a (160/185/230) CH		MATTE BLACK NR271907a (160/185/230) MB
	BRUSHED NICKEL NR271907a (160/185/230) BN		GUN METAL NR271907a (160/185/230) GM
	BRUSHED GOLD NR271907a (160/185/230) BG		

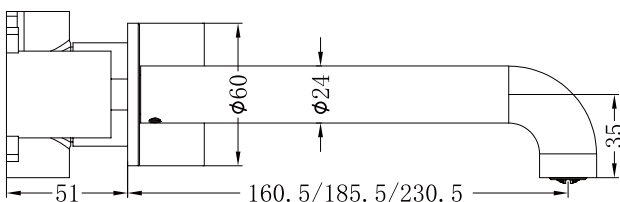
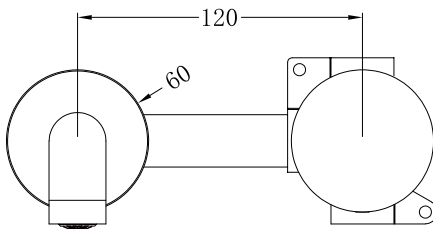

Dimensions are nominal measurements only.



Versions: 2021.11

MAINTENANCE AND CARE

All surfaces should be cleaned with mild liquid detergent or soap and water.

Do not use cream cleaners or citrus based cleaning products, as they are abrasive.

Use of unsuitable cleaning agents may damage the surface. Any damage caused in this way will not be covered by warranty

PACKING INCLUDES

- 1x spout
- 1x plate
- 1x hand wheel
- 1x body
- 1x install kits

Installation Instruction

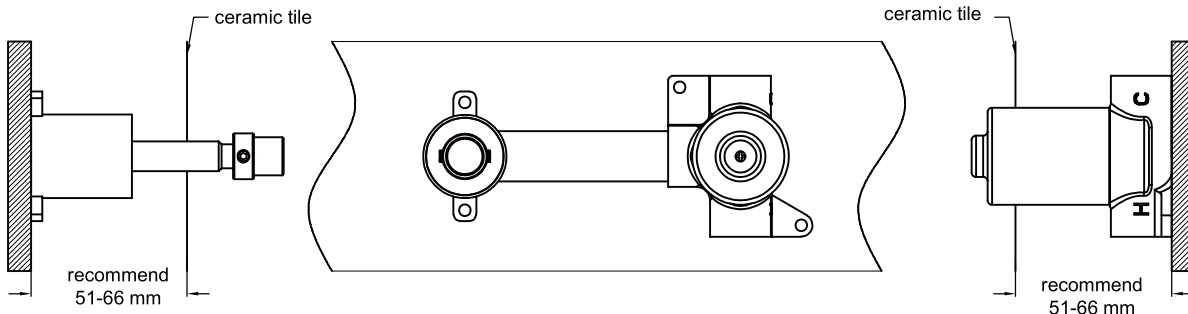

1. Fix body on noggin and ensure installation depth is 51-66mm from noggin to ceramic tile.

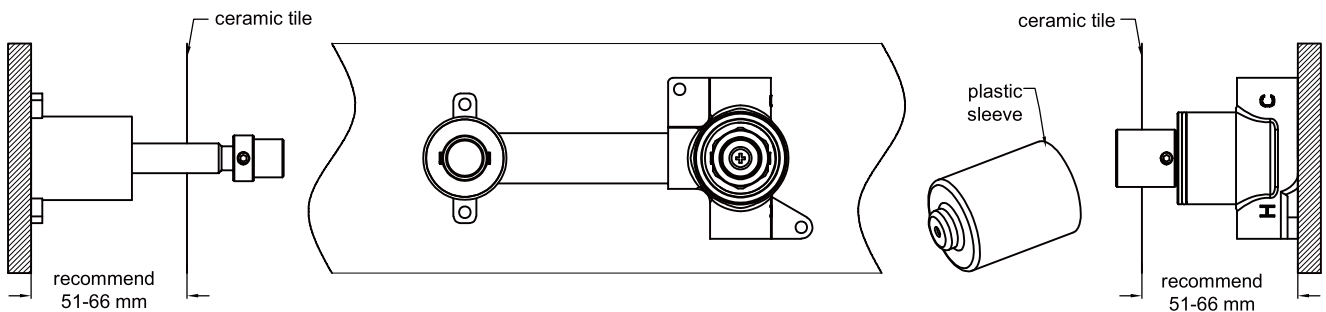

2. Connect cold water hose and hot water hose. take off plastic sleeve and conduct water pressure test for leak.

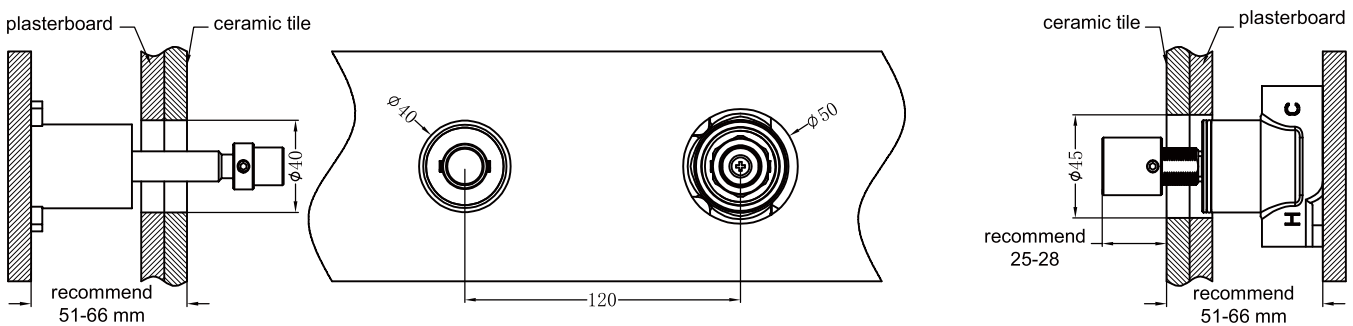

3. Adjust connecting rod and ensure depth is 25-28mm from the front of adaptor to ceramic tile.

Then install plasterboard and ceramic tile after drilling a $\phi 50$ and a $\phi 40$ hole according to above picture.

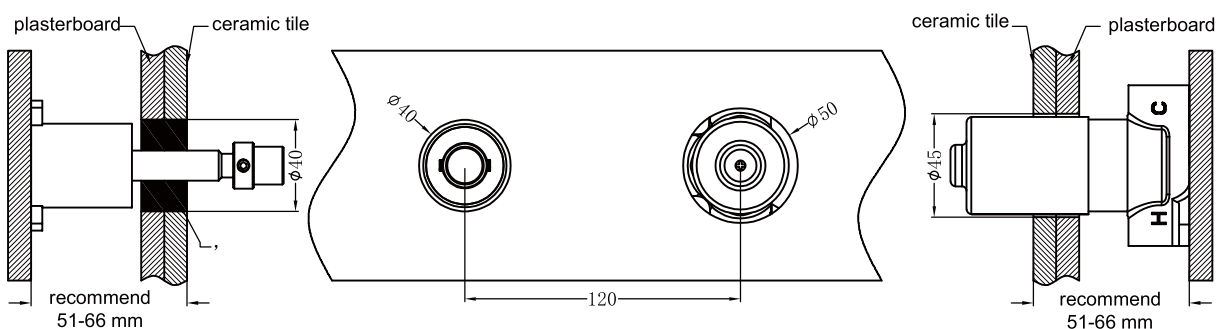

4. Install plastic sleeve back to the body.

