

Smart Toilet

This user' s guide contains the product warranty certificate.  
Be sure to read this user' s guide carefully before use.

## A Trustworthy Smart Toilet Seat !

Our first-class core technology & rigorous QC system  
Make the bidet top product in the world.

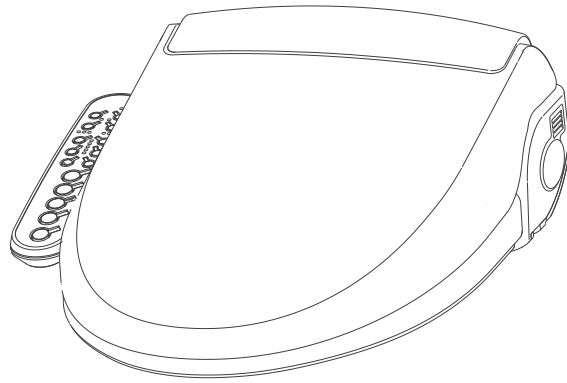

- Posterior wash, female wash, enema wash are set in one nozzle
- Mixed water bubble with air Make the massage wash more comfortable
- High performance of Waterproof
- Easy clean and quick disassembly
- Energy-saving
- Temperature Lock Function (set for saving energy)

## CONTENTS

<b>01</b>	Precautions before use .....	4	<b>PREPARE</b>
	How to Use the Product .....	5	
	Safety Instructions .....	6	
	Product Characteristic & Parts .....	9	
	Identification .....	10	
<b>02</b>	Installation method .....	12	<b>OPERATION</b>
	Initial Operation .....	14	
	Disassembly of Product .....	15	
	Basic Operation .....	16	
	Function Adjustment .....	17	
	Maintenance & Cleaning .....	19	
<b>03</b>	Tank Drain & Operation in Winter .....	20	<b>OTHER</b>
	Instructions Before Repair .....	21	
	Product Specifications .....	22	
	Product Warranties .....	23	
	Harmful and toxic substances of product .....	25	

## BEFORE REQUESTING OPERATION

- 1** Applies to AC220V-240V~ 50/60Hz.

Insert the power plug into the outlet with ground wire, and make sure the power is supplied

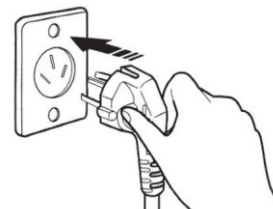

After installation, pls confirm belows

- 2** Open water-valve, confirm there's no leakage  
Water-valve must be opened to operate the machine.

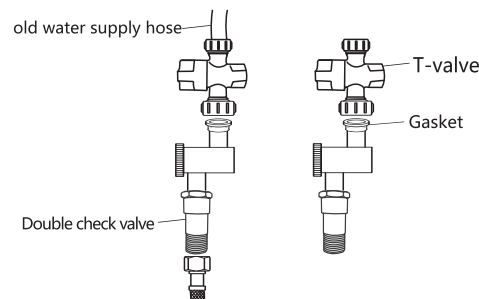

**⚠** Gasket must be installed on T-valve to prevent leakage

- 3** Please clean the filter periodically, and replace the external water feed filter.

Keep cleaning the external filter periodically, or it will cause solid blockage, to the water supply.

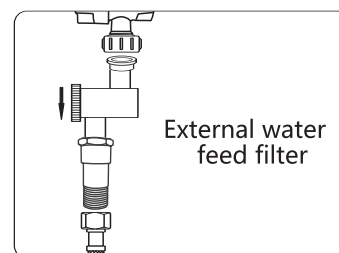

- 4** Please sit on the seat sensor, all the functions work only when the seat sensor is activated.

If human body leaves the seat, nozzle will stop working and get back into the bidet.

If you add children assist seat onto the cover, the machine can't work normally.

- 5** Please confirm the pressure of water supply.

The cleaning water pressure will be low if you use the cleaning function and flush the toilet at the same time.

The nozzle won't be normally operated at excessively low water pressure supply area.

Product maintenance-nozzle

- 1** If you want to clean the nozzle, press  for 3 seconds.

When nobody sits on the bidet, press  for 3 seconds, the nozzle will reach out automatically and stop.

Clean the nozzle by brush, then press  or have someone sit on the bidet, the nozzle will return into the bidet and self-clean it once again.

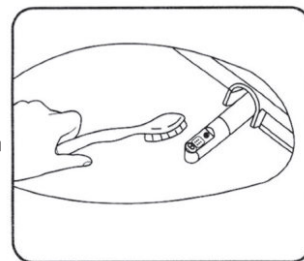

## HOW TO USE THE PRODUCT

- 1** Sit on the toilet seat

Be sure to sit on the seat sensor.

If the sensor is not activated, functions will not work, deodorizing function starts automatically.

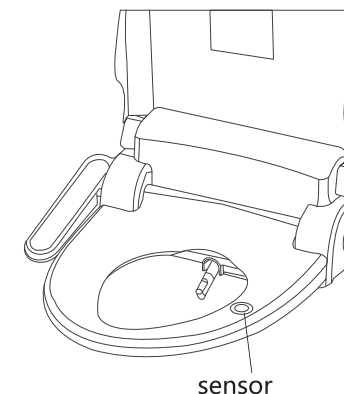

- 2** Press  Posterior /Move  Feminine /Move  Enema /Clean

Press Posterior, Feminine, Enema Wash to select the function you need, press it again in use, the nozzle can move forward and backward, the cleaning function lasts for 1 min.

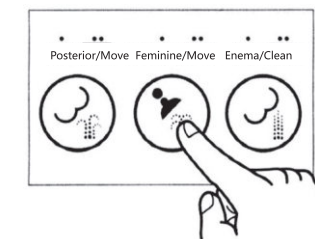

- 3** Press Enema/Clean (ENEMA WASH function)

The Enema function will have warm water cleaning last for 1 min, soft but powerful spout will help stimulating the anus to defecate.

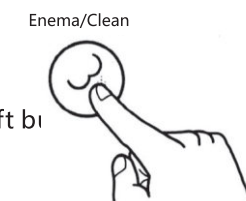

- 4**  Press DRY button

Dryer indicator light on, press to choose the temp level you need.

Dryer function lasts for 3 minutes.

It is recommended to wipe off the water on your body before use

the dryer function.



- 5**  Press the STOP button

If you want to stop any function in use, just press "stop"

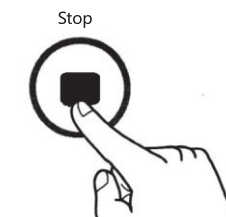

PREPARE

# SAFETY INSTRUCTION

To avoid body injury and property loss, please use correctly and observe this safety instruction strictly

► Each symbol refers to the followings.



**Warning**

Against the warning rules would lead to serious injury or death.



**Caution**

Against the caution rules would lead to minor injuries or property loss.

Don't	Don't	Don't contact with fires	Don't disassembly, modification or repair
	Don't spray water	Don't plug or touch with wet hand.	Don't soak in the water
Must	Must	Do grounding	Remove plug-in

## Warning

### Warning



Disassembly, modification or repair is not allowed.



It would cause electric shock or fire, any questions on product please call our service center.



Don't spray water directly onto the product or power plug.



Would cause electric shock or fire.



Power supply must have ground wire, or it would cause product failure or get electric shock.

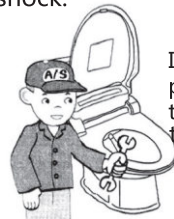

If there's no ground wired plug, please get a professional electrician to install one. Would cause electric shock.



Don't plug or touch the power cord with wet hand.

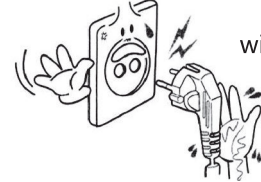

Would cause electric shock.



Long time of using heated seat & dry function, may cause low temperature burn. Children, disabled or sensitive skinned people please pay special attention to it.

## Safety Instructions



**Warning**



Don't connect to power supply before the bidet is completely installed, water supply pipe connected, and water supply valve opened.



• May cause fire or product fault.



Be caution of low temperature burn

- If the skin touch the warm seat for too long it may cause low temperature burn. For children, elderly or disabled people, please set the seat temperature at low level or turn it off.
- If using at a high temperature, for the safety of next user, please set the temperature back into low level after use.



- Don't clean the bidet with detergent, benzene solvent, bleach, paint thinner, etc
- May cause color-fade or surface cracked.



• Even in warranty, product problem caused by these reasons, maintenance will be charged for.



When disassembly or repair, pls be sure to cut the power for safety.

remove the plug-in

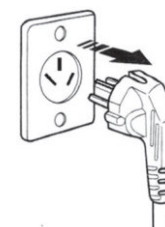

• May cause electric shock



Don't use a multi plug-in

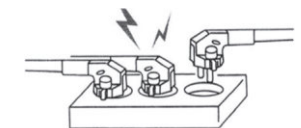

- Please use 220V-240V~power supply.
- Misuse of power supply may cause overheated or fire.
- Ensure use a good quality plug.



Please use tap water, not industrial water.

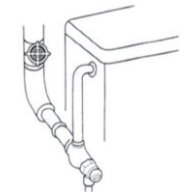

- May cause skin inflammation or product fault.
- Don't put cigarette or flammable materials near the product nor throw them onto it.



Don't



- May cause electric shock or fire.



Be sure to use good quality plug and outlet

Don't

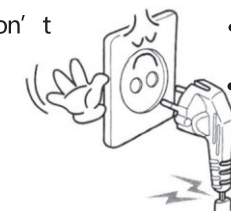

- Only professional person can repair plug and outlet
- May cause electric shock or fire

PREPARE



When children, old or disabled people use the bidet, please have a guarder companied with them

## Safety Instruction



### Notice



Don't stand on the product nor put heavy objects on it.

Don't

Adjust water pressure



- Don't stand on the product or the operation plate.
- May cause injury or damage the product.



Don't pull the cover or the seat overexertedly

Don't



- Don't play it as toys
- May cause product fault



Don't pull or bend the connecting hose.

Don't

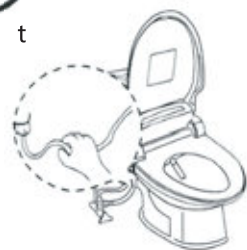

- May cause leakage or block the water supply.



Don't spray urine onto the nozzle or the dryer hole.

Must



- That stinks
- Use a soft brush to clean the nozzle



Don't use when there's problem, call service center

Don't



- When problems occurred, don't use, inform the service center asap, or it may cause electric shock or fire.



Don't block the nozzle and the dryer hole with any object nor your hand.

Don't



- May cause product failure.
- May cause fire or electric shock.
- May cause burn injury.



Don't soak the bidet into water.

Don't



- May cause electric shock



Long time no use, please remove the power plug and drain the water tank.

Must



- Water stored in tank for too long time will breed bacteria and may cause skin disease.

## PRODUCT CHARACTERISTIC & ACCESSORIES

### Characteristic

- Posterior, Feminine, Enema: 3 nozzles in 1 spray bar
- Comfortable Massage wash, abundant air bubbles in water column
- Waterproof & Moistureproof
- Button operation, easy to control
- Energy saving
- Power memory can remember the temperature (lock function)

### Functions

#### ♣ Wash Function

Posterior, Feminine, Enema, Massage wash, Bubble wash, Continuous warm water supply, Nozzle self-cleaning, antibacterial material, and easy to drain water tank.

#### ♣ Quick and Comfort Function

Nozzle position adjustable, seat and dryer wind temperature adjustable, energy-saving Easy disassembly.

#### ♣ Safety Function

Special plastic welding technology make a top class water-proof performance, seat sensor won't operate wash functions until it detect human body sitting on it), fault self examining, electronic tamper-proof and other safety protection devices.

### Accessories

#### Pipe parts

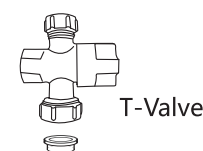

T-Valve

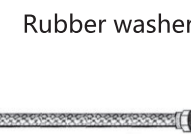

Rubber washer

#### Fixing Parts

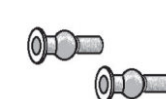

Expansion Screws

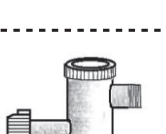

Water Filter



Washer plate

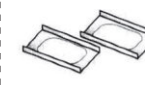

Bracket Holders

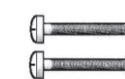

Set screws

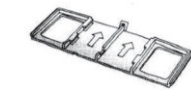

Bracket

#### User Manual

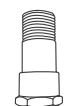

Double check valve

# IDENTIFICATION



## Details

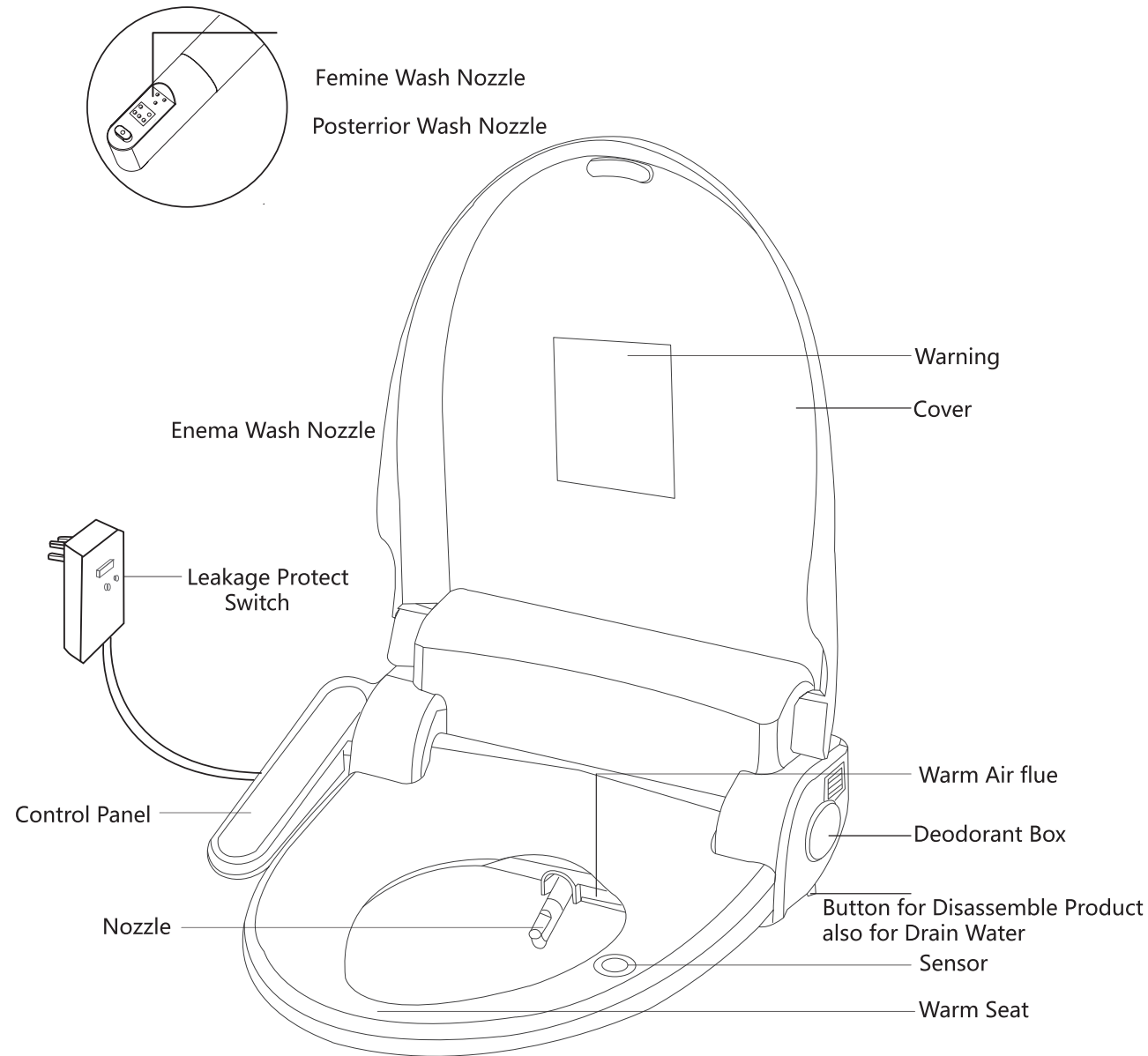







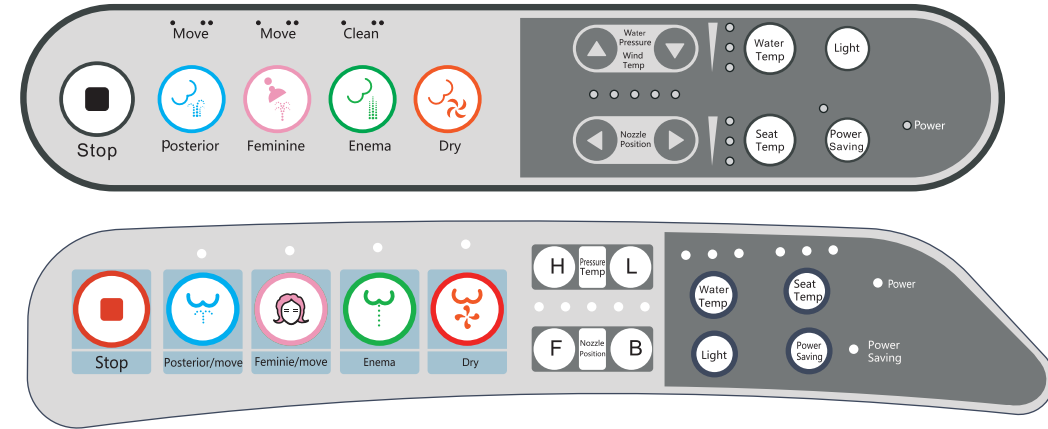



# IDENTIFICATION



## Control Panel



PREPARE

 <p>세정 모드 Posterior Wash</p>	<p>For cleaning the annus, wash for 2 minutes (press again in use, change to move/massage wash)</p>	 <p>비데 모드 Feminine/Mov</p>	<p>Wash for 2 minutes (press again in use, change to move/massage wash)</p>
 <p>배변 모드 Enema</p>	<p>Enema function lasts for 2 minutes</p>	 <p>건조 Dry</p>	<p>Dry function last for 3 minutes</p>
 <p>Pressure Wind Temp</p>	<p>1-5 grades of water pressure adjustable</p>	 <p>Nozzle Position</p>	<p>Control the nozzle location as needed</p>
 <p>Water Temp</p>	<p>4 levels of water temperature adjustable room temperature about 34°C/37°C/40°C</p>	 <p>Seat Temp</p>	<p>4 levels of water temperature adjustable room temperature about 34°C/37°C/40°C</p>
 <p>Power Saving</p>	<p>Power saving function</p>	 <p>Stop</p>	<p>To stop all function</p>

- Be sure to sit on the sensor, if the sensor is not occupied, basic functions will not work.
- The water temperature can set to be about 34°C " low " /37°C " middle " /40°C " high? ,if the supply water is lower than 10°C, the water would be lower than setting temperature.



## INSTALLATION

### ⚠ Before Installation

Power supply: AC220V-240V~50/60Hz(option)

Don't connect to power supply before completely installed and water supply connected.

Ground wire is a must. If no ground,have a professional person to install one.

### Confirm water feed valve

Confirm whether water feed valve work with our accesories, we have 3 T-valve to choose.

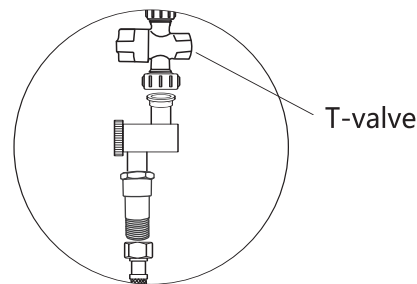

■ Disassembly special water supply valve or pipe, need professional person.

### Installation

**1** Turn clockwise to close the water supply valve, then unscrew the water supply pipe.

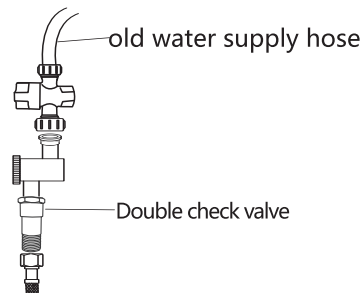

**2** Remove the original toilet cover

Release the two setting nuts then remove the seat cover.  
•Don't throw the cover,keep it for further use.

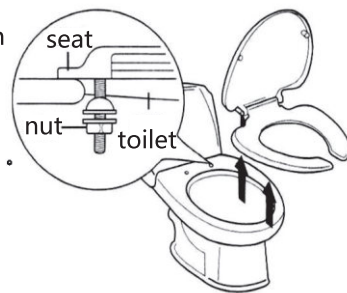

**3** Install T-valve,be sure to install gaskets to avoid leakage

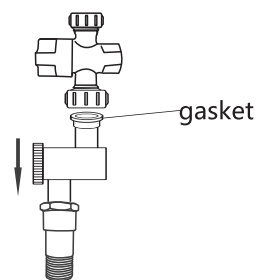

**4** Connect the water supply pipe with T-Valve

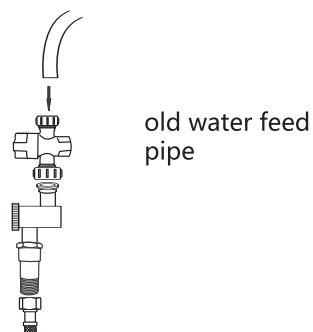

※

## INSTALLATION

**5** Install the fixing accessories according to the following installation sketch map.

**6** After the fixing plate installed,try it with the machine to adjust it at the right position,then let go of the machine and tighten the screws.

1. Fixing plate
2. Setting screw
3. Fixing gasket
4. Expanding nut
5. Gasket
6. The toilet

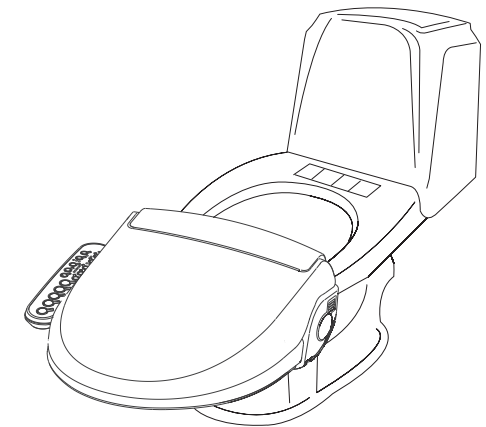
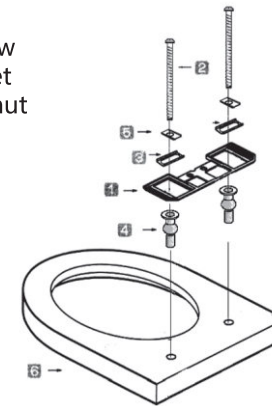

**7** Push the main body along the groove on the fixing plate to completely install the machine. Push it in until it sounds "click" ,install finished

**8** After the main body installed,connect the water supply filter and the main body with pipe in our accessories pack,then connect the other side of the filter to the T-Valve,and turn anti-clockwise to open the valve.

connect the bidet-use hose to the bidet body.

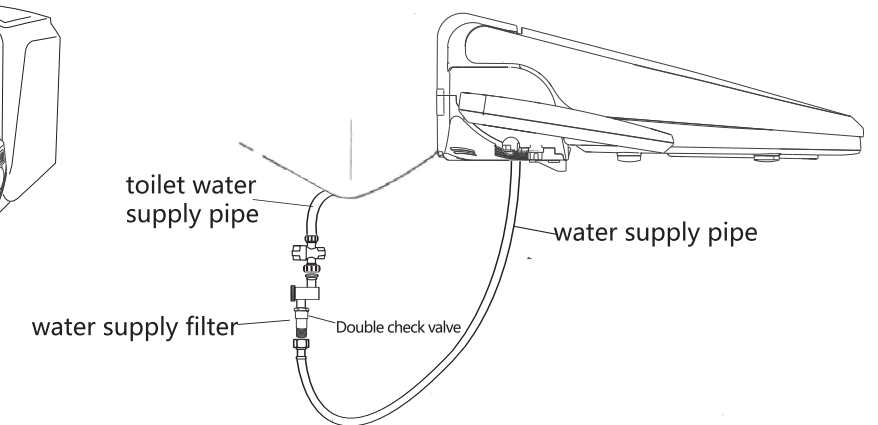
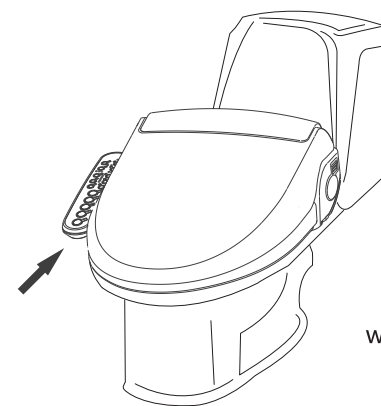

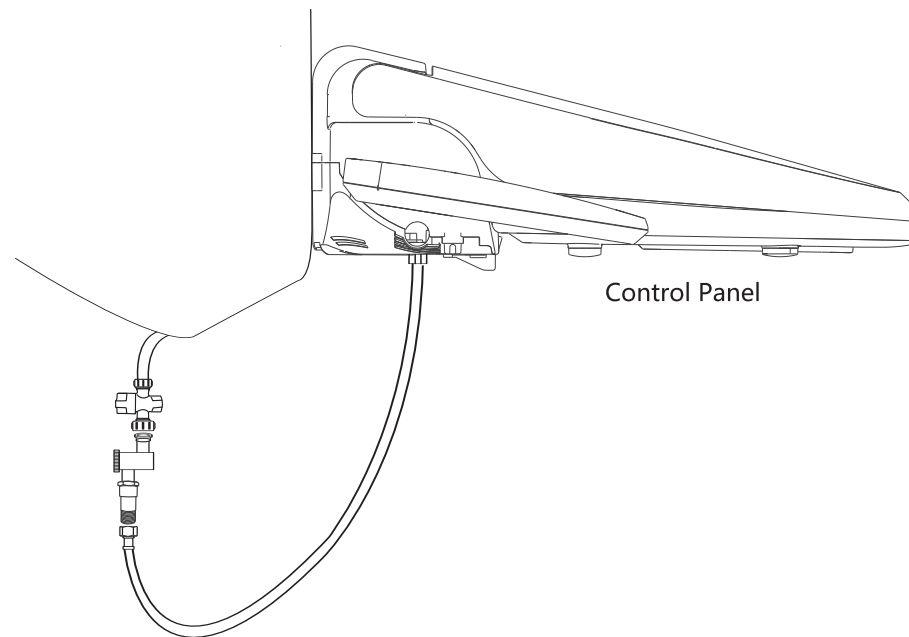

## INITIAL OPEATION

- 1 Turn anti-clockwise to open the water supply valve .  
Make sure there' s no leakage around the joint part.



- 2 The 1st time connect power

- When connected to 220V-240V~power, all indicator twinkles,and the machine buzzer will have 1 long and 2 short sounds,and the nozzle move forward and backward for once and then reset, when you hear "bi" sound, all the above movements stop,power indicator light on,self-checking finished.

- 3 • When nobody seated on,press  Posterior  Feminine or  Enema,it begin to inject water into the water tank,water pressure indicator light is off, when you hear"bi" sound, water injection finished.

- 4 Function confirmation

- Put your hand on the sensor or sit on it, press the function buttons to set the parameters you need.

Notice :

- 1.With human body touching the sensor,press any cleaning button would have water spraying out,be careful not to splashed in your body.

- 2.The functions won't operate unless you touch the sensor.

## DISASSEMBLY OF PRODUCT

- 1 Pull the power plug from the outlet
- 2 Turn clockwise to close the water feed valve
- 3 Press the button on the right side of bidet , completely drain the water tank
- 4 Remove the water feed pipe,disassemble as the following steps.

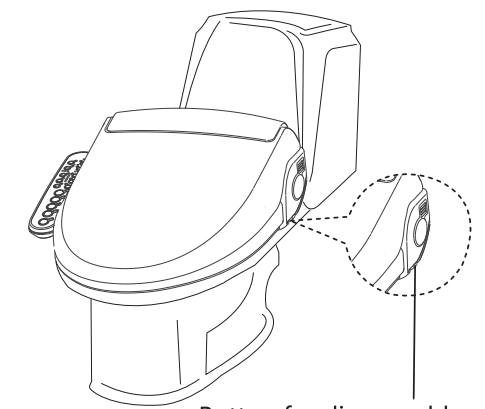

Button for disassemble product also for drain water

- Press Button for disassemble product and hold, at the same time pull the main body forward, and then remove it from the toilet.

 Don' t Reverse bidet when the product is connected to power.

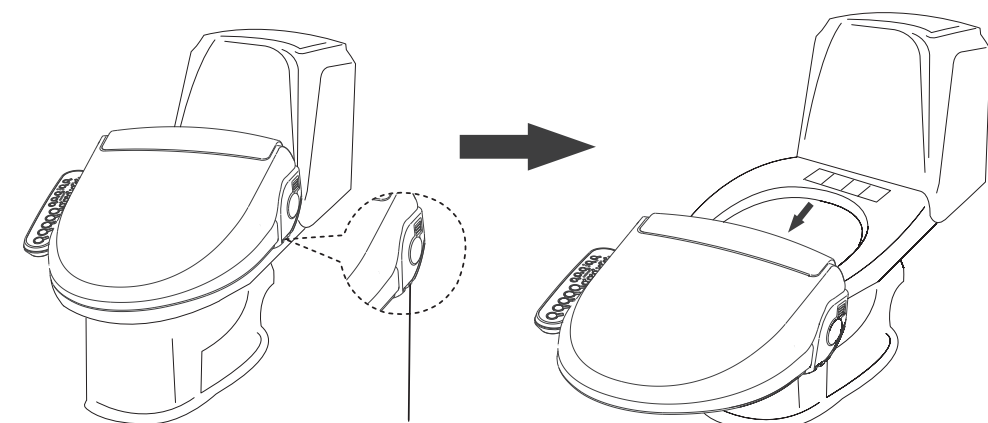

Button for Disassemble Product also for Drain Water

- 5 Screw off the water supply hose and T-valve ( refer to page 12 - page 13 for detail )
- 6 Connect the water supply hose to the water suply valve,turn anti-clockwise to open the valve,and check if there' s any leakage around the joint part.
- 7 After then,install the original toilet cover.

The above mentions from1-4steps are for a normal cleaning of the product. 5-7steps are for a completely disassemble of our product.



## HOW TO USE PRODUCT(BASIC)

### Notice

- When children, elders, sensitive skin people, drunkard and those who are taking pills. use the product, please select seat temperature to "low" or "off" to avoid low temp burn.

### Sit on the toilet seat Feminine/Move Remind

- Be sure to sit on the seat sensor
- Make sure the skin touch the sensor position, clothes will affect the sensitivity of the machine work.
- If the sensor is not occupied, function will not work, Be gentle to press the buttons.

### Select Posterior Feminine Enema

#### Remind

- The POSTERIOR, FEMALE & ENEMA WASH function last for 1min and stop automatically, if you want to continue, press it again.
- In the use of POSTERIOR, FEMALE & ENEMA WASH function, press the button again, the nozzle begin to move forward and afterward doing massage wash.

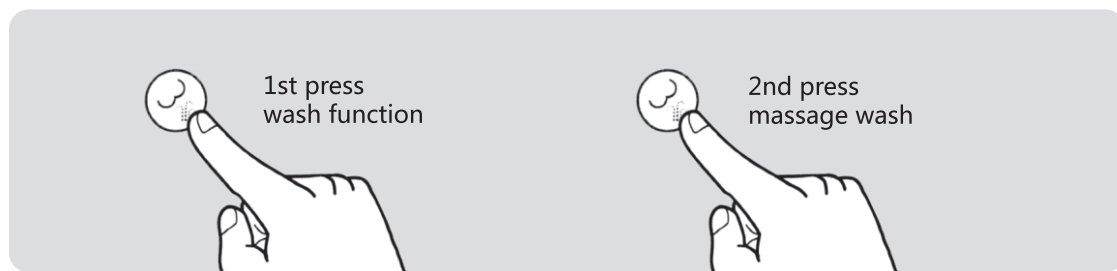

### Press Dry button

- Hot air indicator lamp will light on
- Dryer works for 3 minutes
- It is recommended to wipe out the water on your button operating the dry function for improving dry effect

### Press the Stop button

- Any operation will stop.

## HOW TO USE PRODUCT(FUNCTION)

### Water Pressure Control

- Press button ▲ HI ▼ LOW, to adjust water pressure
- Check the water filter regularly for stable use, if it's blocked, it may cause low water pressure.
- The more light on the higher the ( ) water pressure.

※ The initial setting is 3rd ( ) level.

### Water temperature Control

- Press , indicator ( ) changes, choose the temperature you need.

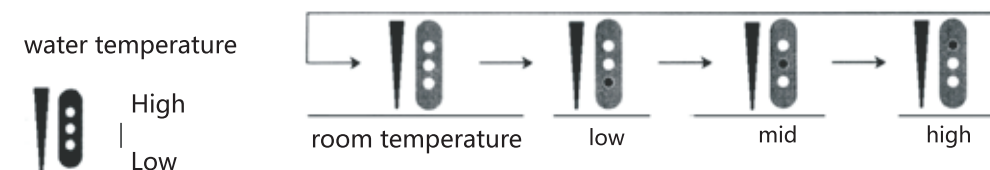

### Seat Temperature Control

- Press , Indicator ( ) changes, choose the temperature you need.

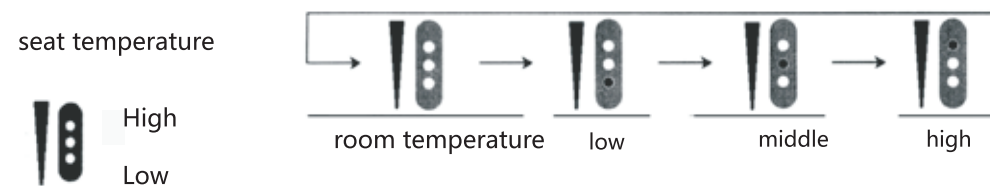

- Remind
- Seat temperature changes according to the room temperature.
  - Long time no use, close the cover to save power and heat.

- Confirm
- The machine has power memory, if the power is cut off and restart the machine, it will remember the parameter set before.

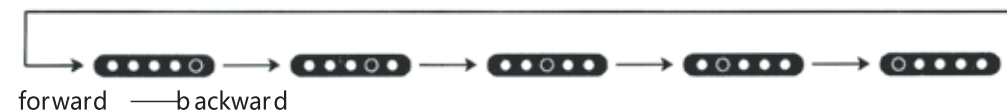

### Nozzle Position Control

- Press ◀ ▶ to control the nozzle position.
- The initial setting is 3rd level.
- The following shows how the indicator changes when you press the button:



## HOW TO USE THE PRODUCT (FUNCTION)

### Dry

- Press Dry, the indicator shows  hot air temperature
- Press  ▲ Hi ▼ Low to right hot air temperature.
- 5 levels of temperature selectable.
- The more indicator lights on, the higher the temperature.

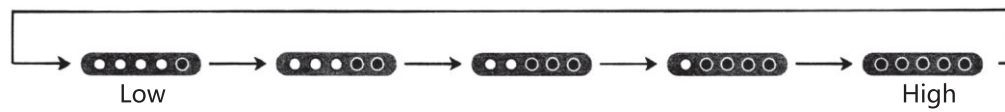

### Move/Massage wash

- In the use of posterior or feminine wash, press the button again it will change to move/massage wash.
- Then Press the button again, it stop move and change to normal cleaning.



press 1st time--wash



press 2nd time--move wash

### Light

- Press " Light " button to start or stop the function.
- Normally, the light is set at off state, when be seated, the light starts automatically and 10 seconds after
- people leave the seat, it will stop automatically.

### Power saving

- Press " power saving ", to see the indicator light on, the function start.
- In power saving mode, seat temperature and water temperature is set at about 28°C.
- Press " power saving ", to see the indicator light off, the function stop.
- When be seated, the power saving automatically closed and work normal, when people leave the seat, it starts automatically again.

 In power saving mode, water and seat temperature will be lower than normal mode.

## MAINTENANCE & CLEANING

### Notifications



1. For power saving, close the seat cover after use can help keep the heat.
2. Set a low temperature, and according to different season, adjust different temperature.
3. Remove the power plug if long term non-use.

### Nozzle self clean

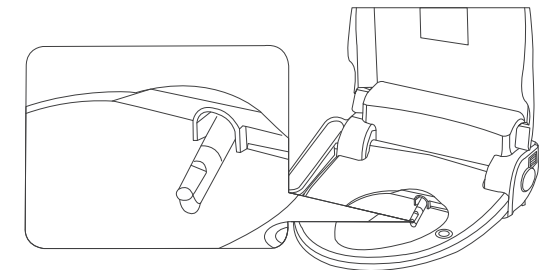
- To ensure non pollution clean water, nozzle will automatically self-clean before and after use.



### Cleaning of Nozzle

- Press the WASH button  for 3 seconds, the nozzle will move forward and stop (for 2 minutes).
- Clean the nozzle with a soft brush, then press "STOP"  button, the nozzle will return to the bidet and self-clean once again.

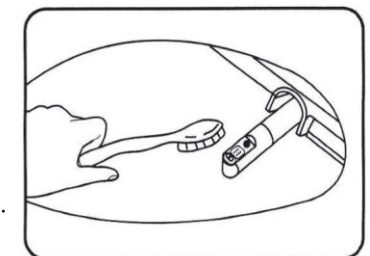

### Cleaning of Bidet Body

1. Exterior surface of bidet is made of plastic material, so do not clean it with abluent, benzene, bleach, paint thinner, etc.
  - ➔ Will cause color fade or damage.
2. Do not spray water directly onto the surface.
  - ➔ Will cause fire or machine fault.
3. Before clean work, please be sure to cut the power, and do not splash any water to the power plug or outlet.
4. After cleaning, wipe the surface with a soft dry cloth.

 An incorrect wash method would cause color fade or damage, we will charge for repair these problems.

## MAINTENANCE

### Cleaning of Water pipe filter

1. Close the water feed valve by turning it clockwise
2. Disconnect the water supply hose. Take the screen filter out and clean it with soft brush.(e.g. toothbrush)
3. After cleaning, place it back. Then connect the water supply hose.
4. Open the water feed valve by turning it anti-clockwise.

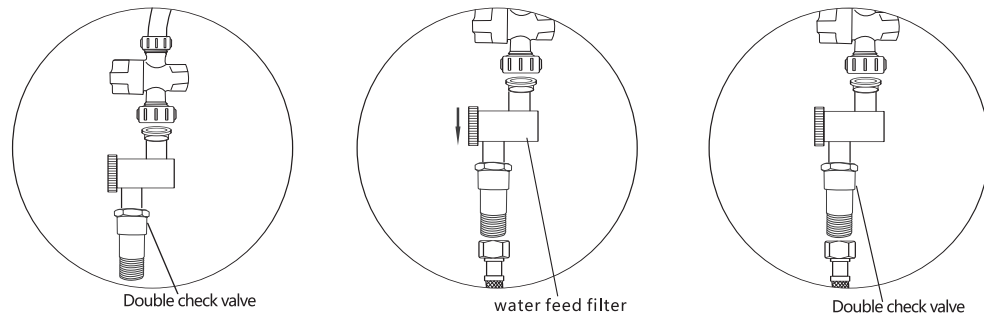

### Drainage of water tank

- 1 Remove the plug to cut the power.
- 2 Cut off water supply by turning the water feed valve clockwise.
- 3 Please drain the water tank if the bidet is unused for a long time, Press the draining button at the right side of bidet to drain off the water directly into the toilet.

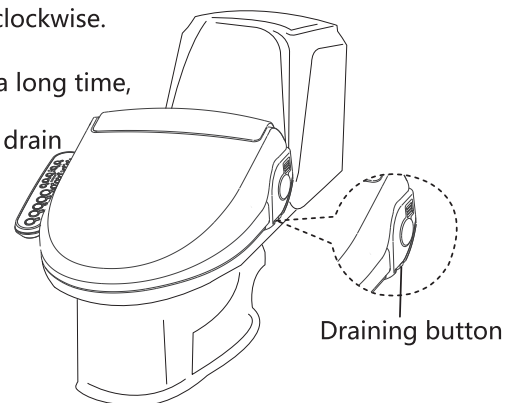

### Usage in winter

- 1 Plug in power supply until the power indicator light is on.
- 2 To avoid water frozen, press  to set a water temperature level, should at least set a "low" level.
- 3 If non-use for a long time, please remove power plug, and drain the water tank.



## INSTRUCTIONS BEFORE REPAIR

\* Please check the following points before requesting the repair of the product.

Signs to occurred	check method
Completely out of operation	Check the power indicator light is on; Check if the power plug is not connected; Check if the human body sits on the seat sensor position.
No water sprays out	Check if the water supply is suspended; Check if water feed valve is locked; Check if nozzle is blocked; Check if connection hose is bent.
Water pressure is low	Check if water pipe filter is blocked; Check if the water pressure is set at low level
Water/Seat/Dry temperature is not warm enough	Check if their temperature is set at "off" or "low" level
The Nozzle doesn't work	Check if human body sit on the seat sensor position.
Enema wash is not operated	Check if it is set at CHILD mode
Machine shake	Tighten the screws
Warm wind dry is not operated	Seat on, and touch the sensors

## PRODUCT SPECIFICATIONS



Model			
Rated voltage		AC220V -240V~	
Rated frequency		50Hz	
Rated power		600W	
Water Supply	Connection	Directly Connect to Waterpipe	
	Water pressure	0.1MPa-0.75MPa	
Wash Unite	Posterior wash	0.7-0.9L/min	
	Feminine wash	0.7-0.9L/min	
	Water pressure	1-5 grades : adjustable	
	Water temperature	Room temperature, about 34,37,40 Celsius 4 grades adjustable	
	Heater capacity	400 W	
	Safety device	Water temp sensor, Water Level Switch, Overheating prevention circuit	
Heated Seat	Seat temperature	Room temperature, about 34,37,40Celsius 4 grades adjustable	
	Heater capacity	45 W	
	Safety device	Overheating prevention circuit, Thermostatic switch	
Dry	Warm air temp	-	about 44°C、48°C、52°C、56°C
	Heater capacity	-	200W
	Safety device	-	Overheating Thermal Cutoff
Deodorant	-	o	
Laxative	o		
Power saving	o		
Light	o		
Leakage Current Detector Inte	o		
Water supply temperature	5°C -35°C ( 37.4°F -95°F ) (suggest 12°C -34°C)		
Using ambient temperature	3°C -40°F ( 37.4°F -104°F )		
Dimension	L: 496mm W: 478mm H: 185mm L: 525mm W: 478mm H: 185mm		
Weight	5.4kgs (packed 8.9 kgs) 5.3kgs (packed 8.8 kgs)		

## PRODUCT WARRANTIES



### Product Warranties

Thanks for buying our products.

The product is warranted for 24 months according to the description written on this warranty;

Please fill the warranty card carefully when you buy the product, and keep properly;

Any questions, submit this warranty card to local dealer



Product name	Electronic bidet	Model	
Serial No.		Invoice No.	
Purchaser		Install Date	
Address			

#### Paid maintenance terms

- Defects and /or fault caused by improperly install or misoperation that against the installation manual.
- Damage from abuse ,fire, flood, freeze, and any other acts of nature.
- Damage resulting from unauthorized alterations, attachments and /or repairs.
- Damage from installing the unit in an environment with animals, mice or insects.
- Damage caused by excess moisture or from water clogging the water closet.
- Damage from not being installed in accordance with all applicable local codes, ordinances and good trade practices.
- Color fading due to use in inappropriate environment.
- Damage from consumable chemicals.
- The warranty will not be covered without providing the date of purchase with original receipt.



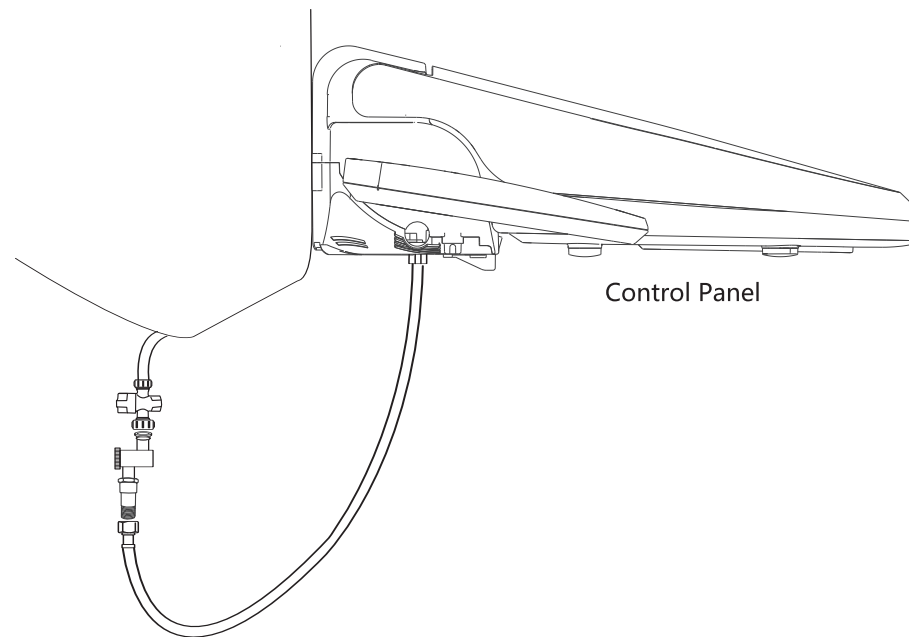

**IMPORTANT**

For Australian market only

A certified dual check valve is supplied and must be installed after the water supply point.

The product must be installed complying with relevant PCA requirements.

- 1** Connect the dual check to water supply point. Please ensure dual check is installed in the correct direction as marked on its body.
- 2** Then connect one end of the hose/filter assembly to the dual check valve.
- 3** Ensure the other end of hose/filter assembly is tightly connected to the shower toilet main body.

Name and content of harmful substances in products

Name of parts	Harmful Substance					
	Pb	Hg	Cd	Cr(VI)	PBB	PBDE
Main board	●	○	○	○	○	○
Remote control	●	○	○	○	○	○
Battery	●	○	○	○	○	○
Accessories	●	○	○	○	○	○

This form is compiled in accordance with the «Regulations on the Control of the Restriction of the Use of Hazardous Substances in Electrical and Electronic Products» .

- Indicates that the content of this hazardous substance in all homogeneous materials of the part is below the limit requirement specified in the relevant standards.
- Indicates that the hazardous substance is at least in a homogeneous material of the part exceeding the limit requirement of specified in the relevant standards. And there is no mature alternative in the industry at present, but it meets the requirements of environmental protection.



The figure in this logo indicates that the product has an environmentally friendly life of 10 years under normal use. The figures in this logo indicate that the product has an environmentally friendly life of 10 years under normal use. Some components may also have an environmentally friendly age mark, and their useful life is based on the number in the logo. Depending on different model, the product may not include all the above components except the main unit. Please refer to the actual sales configuration of the product.

**Environmental protection**

- Do not dispose of the product and its parts as ordinary household waste.
- Please comply with local laws and regulations on handling of this product and its components and support recycling operations.