

MIKA

Wall Basin Mixer w Faceplate

- 2121252100 | Chrome
- 2121252110 | Brushed Nickel
- 2121252160 | Brushed Brass
- 2121252170 | Matte Black
- 2121252190 | Gun Metal

WELS 5 Stars 6.0L/Min | AP | Fixed Spout | 190mm

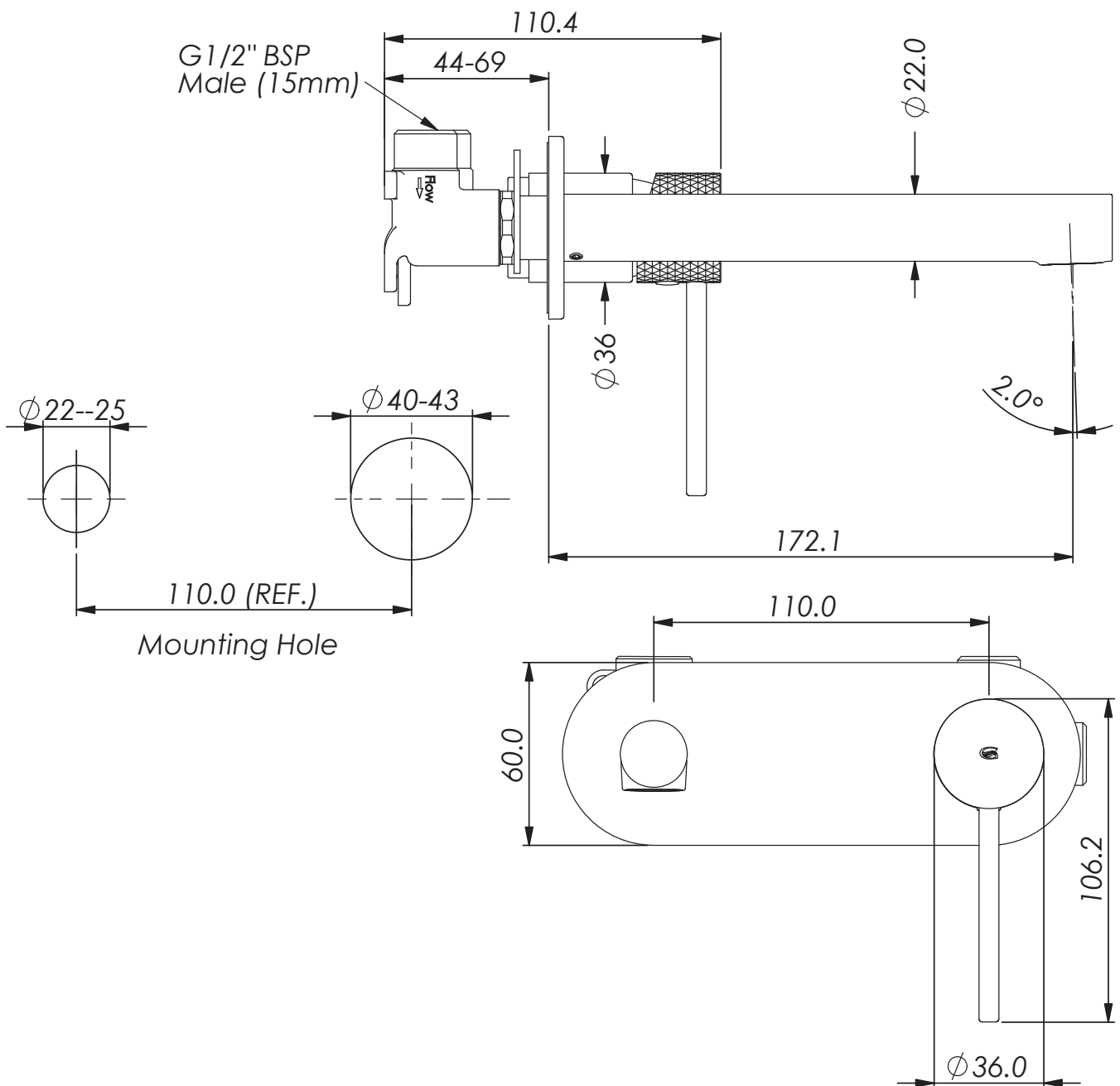

NZ PHONE - 0800 655 455
 EMAIL - nzsales@greenstapware.com
 WEBSITE - greenstapware.com





MACI & MIKA WALL BASIN / BATH MIXER WITH PLATE

(For Mains Pressure Installations Only)

PRODUCT #

BATCH #

ATTENTION PLUMBER

To ensure the optimum performance and customer satisfaction please adhere to the following:

- **Flush out all pipe work prior to installation.**
- Installation shall be in accordance with the AS/NZS3500 series of standards.
The maximum operating pressure within any building should not exceed 500kpa.
Pressure above 500kpa can cause damage from water hammer, reducing life of appliances, taps and fittings and cause excessive noise in the plumbing system.
- Pressure over 500kPa will require a limiting valve.
- Inline strainer / filter must be installed in the line before the mixer to cover both hot and cold supplies (not supplied). Must be accessible.

TECHNICAL DATA

- Minimum Water pressure for satisfactory operation: 150kPa
- Maximum Water pressure: 500kPa
- Maximum hot water temperature: 70°C
If the Water temperature exceeds 70°C an approved Tempering Valve must be fitted.
- The flow rate of the sink and basin mixers has been rated under the NZ Water Efficiency Labeling Scheme (WELS) to 5 Star — 6.0 litres per minute.

Please leave this form with the product once installed.

For full warranty terms and conditions, please see the warranty card enclosed with this product or visit www.greenstapware.com/warranty-and-care/

NZ

Distributed by: Greens Global Limited

PO Box 5055, Hamilton, 3200

22 The Boulevard, Te Rapa, Hamilton 3200

Phone: 07 849 0109, Fax: 07 849 0540

Website: www.greenstapware.com

Email: nzsales@greenstapware.com

Service Hotline: 0800 655 455

42148 11/21

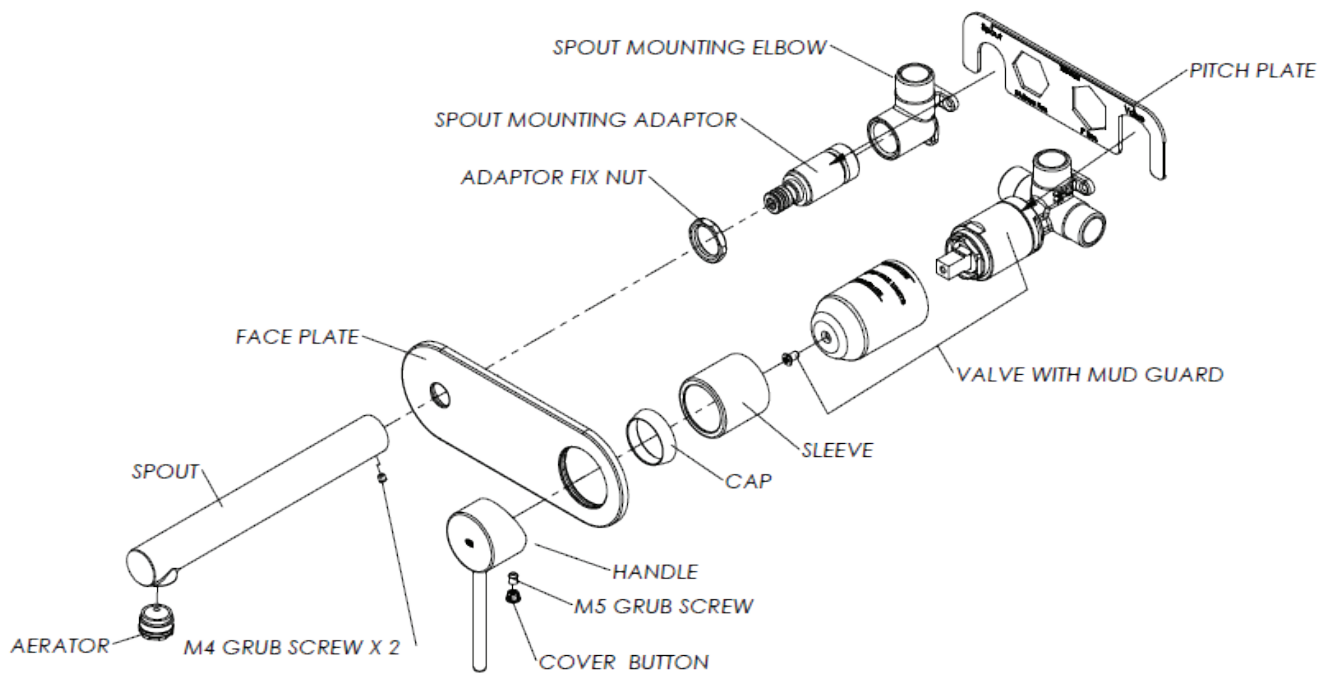
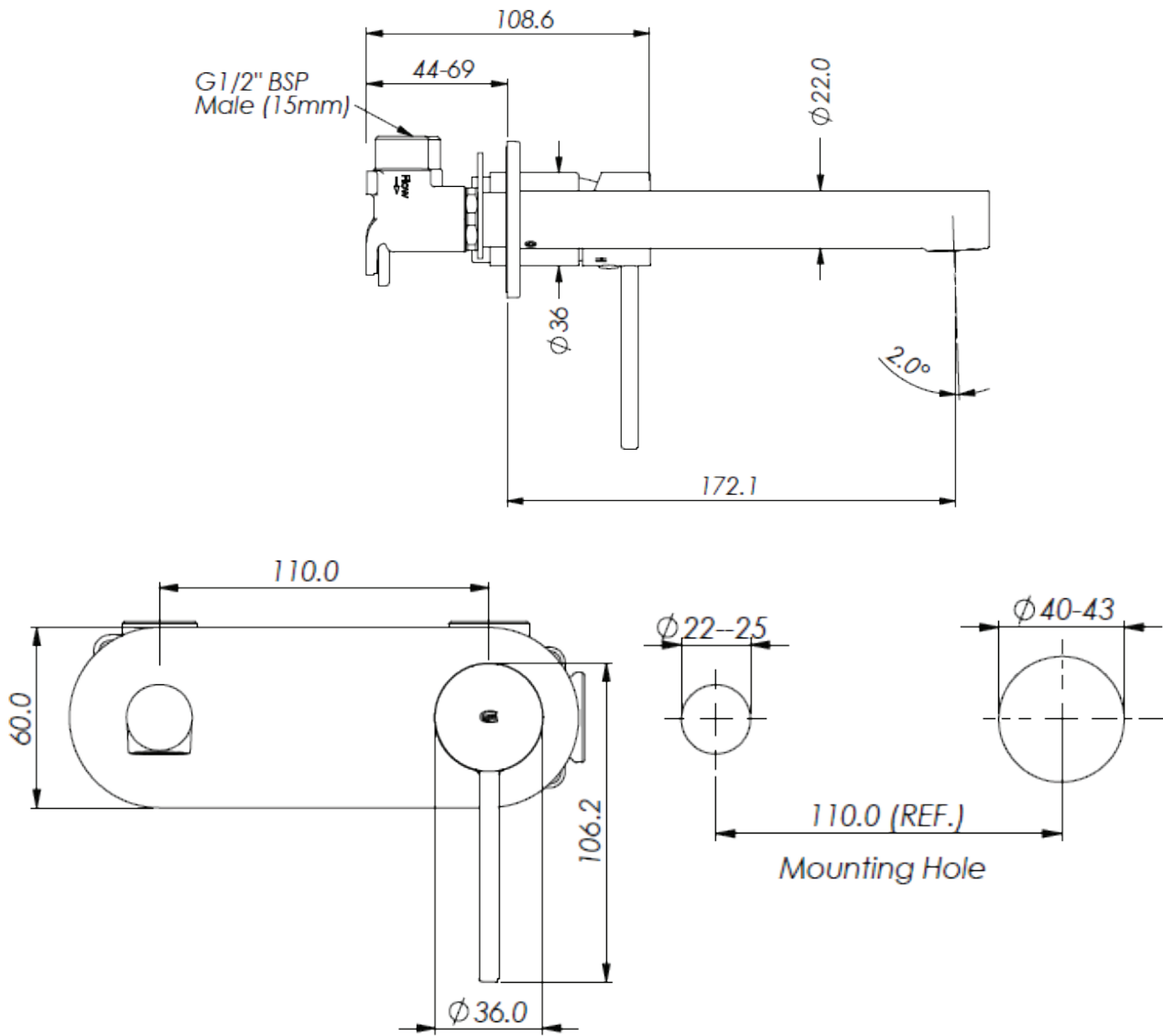

**NOTE: Spout can be installed on the left or right side of the mixer valve.
Valve body mounting 44-69mm behind finished wall
Finished wall cut-out: Mixer 40-43mm dia round.
Spout 22-25mm dia.**

Installing Mixer Valve Body:

1. **15mm Male** inlets & outlet.
 - a. Hot inlet (left), Cold inlet (Right)
 - b. Outlet (Top).
2. **44mm - 69mm back of valve body to the finished wall.**
3. Finished wall cut-out : **Mixer 40-43mm dia round, Spout 22-25mm dia.**
4. Do not pressure test with valve in the open position when the outlet is closed.

Installing Spout Mounting Elbow:

1. Install the brass 15mm mounting elbow for spout position and connect water supply from mixer outlet to elbow.
 - a. **Check alignment of valve body and spout mounting using the pitch plate.**
 - i. Sit the pitch plate in the **groove of valve body** and sit **over the mounting tube.**
 - ii. Check is level with a spirit level.
 - b. Install the G1/2" threaded tube to the mounting elbow.
 - i. Using a 12mm Allen key (Not supplied).
 - ii. Note: **Must have MAX 15mm thread** from finished wall for adaptor.
 - c. Install the fix nut and tighten against the mounting elbow.
 - d. To water test, cap off using a 15mm threaded plug (not supplied).

Install Face Plate & Handle:

1. Remove the mud guard by removing the screw.
2. Push on sleeve, screw on cap.
2. Remove the protective tape from the seal and slide the faceplate over the mixer body and mounting for elbow and position against the wall lining.
 - a. Plate is reversible.
3. Ensure the seal is in place on inside of plate for valve body and spout.
4. Sealant will be required behind faceplate on uneven surfaces for water seal.
5. Install the handle with the 2.5mm Allen key supplied and fit button.

Installing Spout & Mounting Adaptor:

1. Remove the mounting adaptor from spout by unscrewing the grub screws under the spout until nearly out.
 - a. This is to ensure the O-rings on the adaptor are not cut.
2. Install spout mounting adaptor.
 - a. Use spanner or 12mm Allen key.
 - b. Cut threaded tube to **MAX 15mm of thread** from finished wall.
2. Grease the O-rings on the adaptor and install spout and tighten grub screws.

PTO

WELS & Bath Installations:

Mixer is set up for basin installations with a 4 Star rating 7.0 l/m aerator.

For bath installations remove the 4 star rated aerator by unscrewing anti-clockwise and replace with flow straightener, using tool supplied.

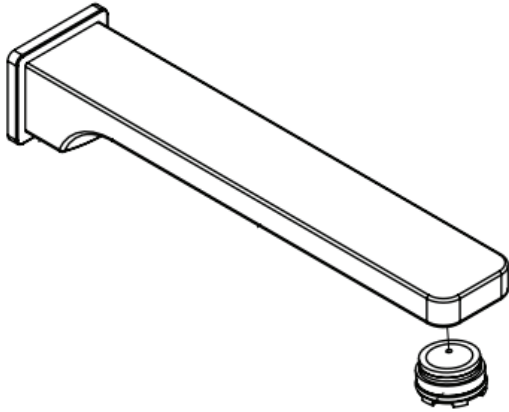



MACI & MIKA WALL BASIN / BATH MIXER WITH PLATE (For All Pressure Installations) INSTALLATION INSTRUCTIONS

PRODUCT #

BATCH #

ATTENTION PLUMBER

To ensure the optimum performance and customer satisfaction please adhere to the following:

- **Flush out all pipe work prior to installation.**
- Installation shall be in accordance with the AS/NZS3500 series of standards.
The maximum operating pressure within any building should not exceed 500kpa.
Pressure above 500kpa can cause damage from water hammer, reducing life of appliances, taps and fittings and cause excessive noise in the plumbing system.
- Pressure over 500kPa will require a limiting valve.
- Inline strainer / filter must be installed in the line before the mixer to cover both hot and cold supplies (not supplied). Must be accessible.

TECHNICAL DATA

- Minimum Water pressure for satisfactory operation: 35kPa
- Maximum Water pressure: 500kPa
- Maximum hot water temperature: 70°C
If the Water temperature exceeds 70°C an approved Tempering Valve must be fitted.
- The flow rate of the sink and basin mixers has been rated under the NZ Water Efficiency Labeling Scheme (WELS) to 5 Star — 6.0 litres per minute.

Please leave this form with the product once installed.

For full warranty terms and conditions, please see the warranty card enclosed with this product or visit www.greenstapware.com/warranty-and-care/

Distributed by: Greens Global Limited
PO Box 5055, Hamilton, 3200
22 The Boulevard, Te Rapa, Hamilton 3200
Phone: 07 849 0109, Fax: 07 849 0540
Website: www.greenstapware.com
Email: nzsales@greenstapware.com
Service Hotline: 0800 655 455

42148 06/22

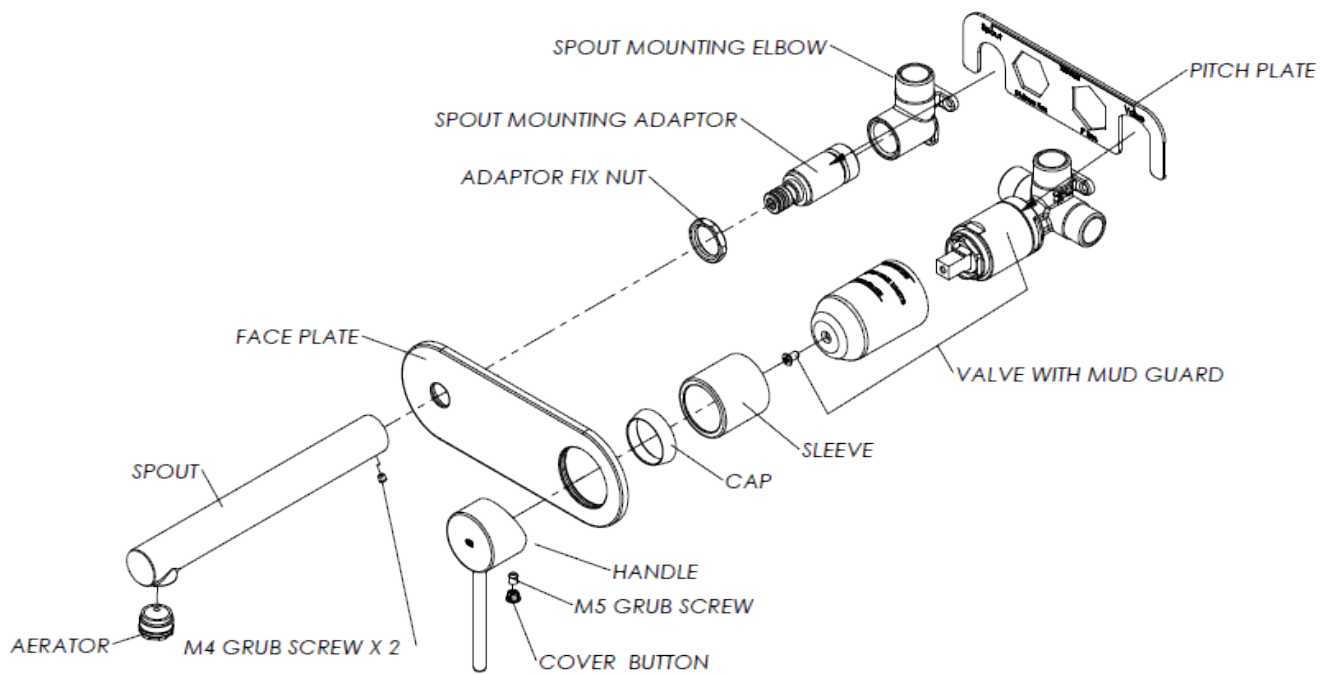
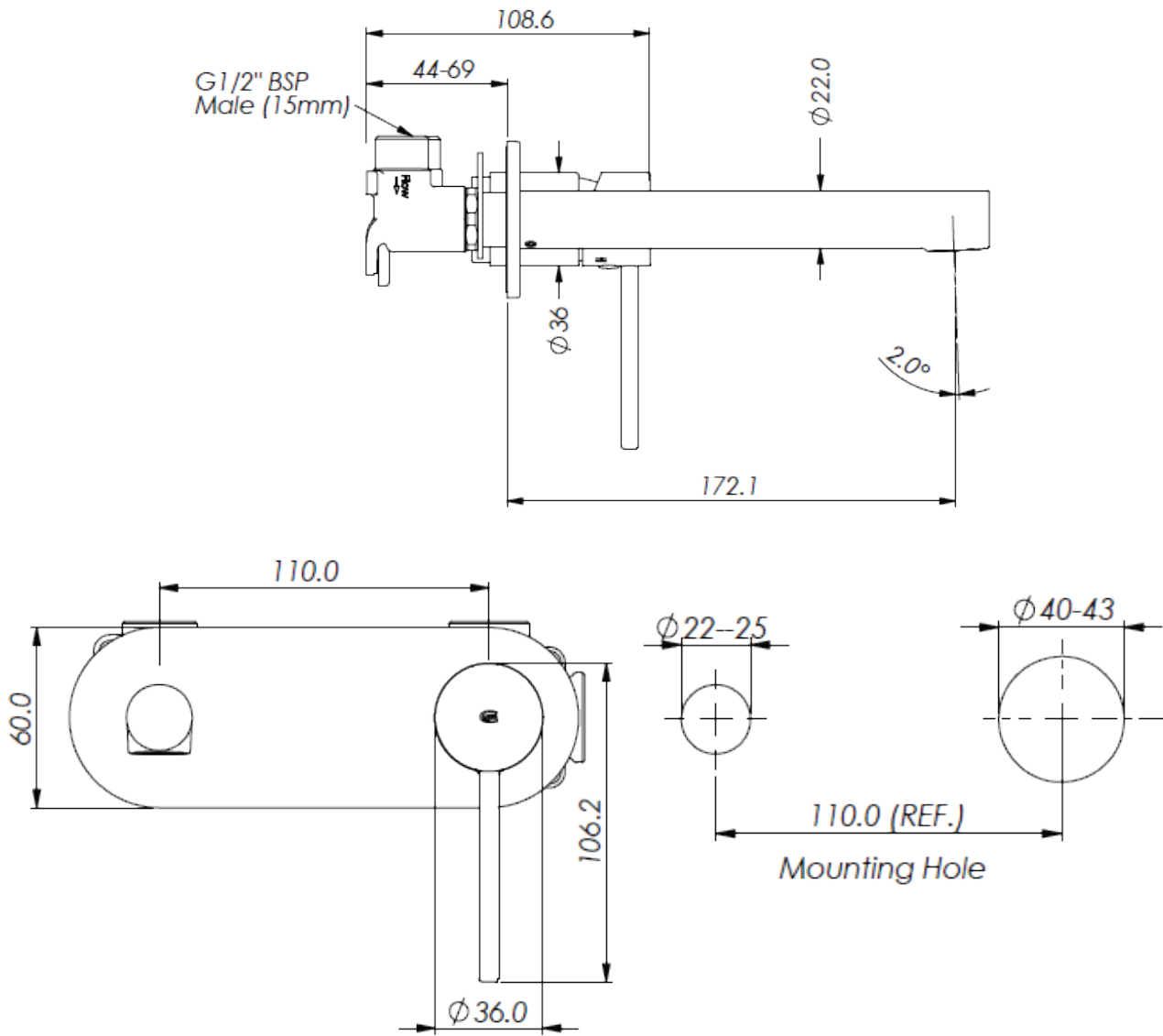

NOTE:

- Spout can be installed on the left or right side of the mixer valve.
 - Valve body mounting 44-69mm behind finished wall
 - Finished wall cut-out: Mixer 40-43mm dia round.
Spout 22-25mm dia.
 - **UNEQUAL PRESSURE: NON-RETURN MUST BE INSTALLED TO THE LOW PRESSURE HOT INLET OF VALVE.**
-

Installing Mixer Valve Body:

1. **Unequal Pressure**: Install non-return to hot inlet of mixer valve (arrow for flow).
2. **15mm Male** inlets & outlet.
 - a. Hot inlet (left), Cold inlet (Right)
 - b. Outlet (Top).
3. **44mm - 69mm back of valve body to the finished wall.**
4. Finished wall cut-out : **Mixer 40-43mm dia round, Spout 22-25mm dia.**
5. Do not pressure test with valve in the open position when the outlet is closed.

Installing Spout Mounting Elbow:

1. Install the brass 15mm mounting elbow for spout position and connect water supply from mixer outlet to elbow.
 - a. **Check alignment of valve body and spout mounting using the pitch plate.**
 - i. Sit the pitch plate in the **groove of valve body** and sit **over the mounting tube.**
 - ii. Check is level with a spirit level.
 - b. Install the G1/2" threaded tube to the mounting elbow.
 - i. Using a 12mm Allen key (Not supplied).
 - ii. Note: **Must have MAX 15mm thread** from finished wall for adaptor.
 - c. Install the fix nut and tighten against the mounting elbow.
 - d. To water test, cap off using a 15mm threaded plug (not supplied).

Install Face Plate & Handle:

1. Remove the mud guard by removing the screw.
2. Push on sleeve, screw on cap.
2. Remove the protective tape from the seal and slide the faceplate over the mixer body and mounting for elbow and position against the wall lining.
 - a. Plate is reversible.
3. Ensure the seal is in place on inside of plate for valve body and spout.
4. Sealant will be required behind faceplate on uneven surfaces for water seal.
5. Install the handle with the 2.5mm Allen key supplied and fit button.

Installing Spout & Mounting Adaptor:

1. Remove the mounting adaptor from spout by unscrewing the grub screws under the spout until nearly out.
 - a. This is to ensure the O-rings on the adaptor are not cut.
2. Install spout mounting adaptor.
 - a. Use spanner or 12mm Allen key.
 - b. Cut threaded tube to **MAX 15mm of thread** from finished wall.
2. Grease the O-rings on the adaptor and install spout and tighten grub screws.

WELS & Bath Installations:

Mixer is set up for basin installations with a 4 Star rating 7.0 l/m aerator.

For bath installations remove the 4 star rated aerator by unscrewing anti-clockwise and replace with flow straightener, using tool supplied.

