

MIKA

Gooseneck Sink Mixer

- 212125400 | Chrome
- 212125410 | Brushed Nickel
- 212125460 | Brushed Brass
- 212125470 | Matte Black
- 212125490 | Gun Metal

WELS 5 Stars 6.0L/Min | AP | Swivel Spout
| Smart Aerator

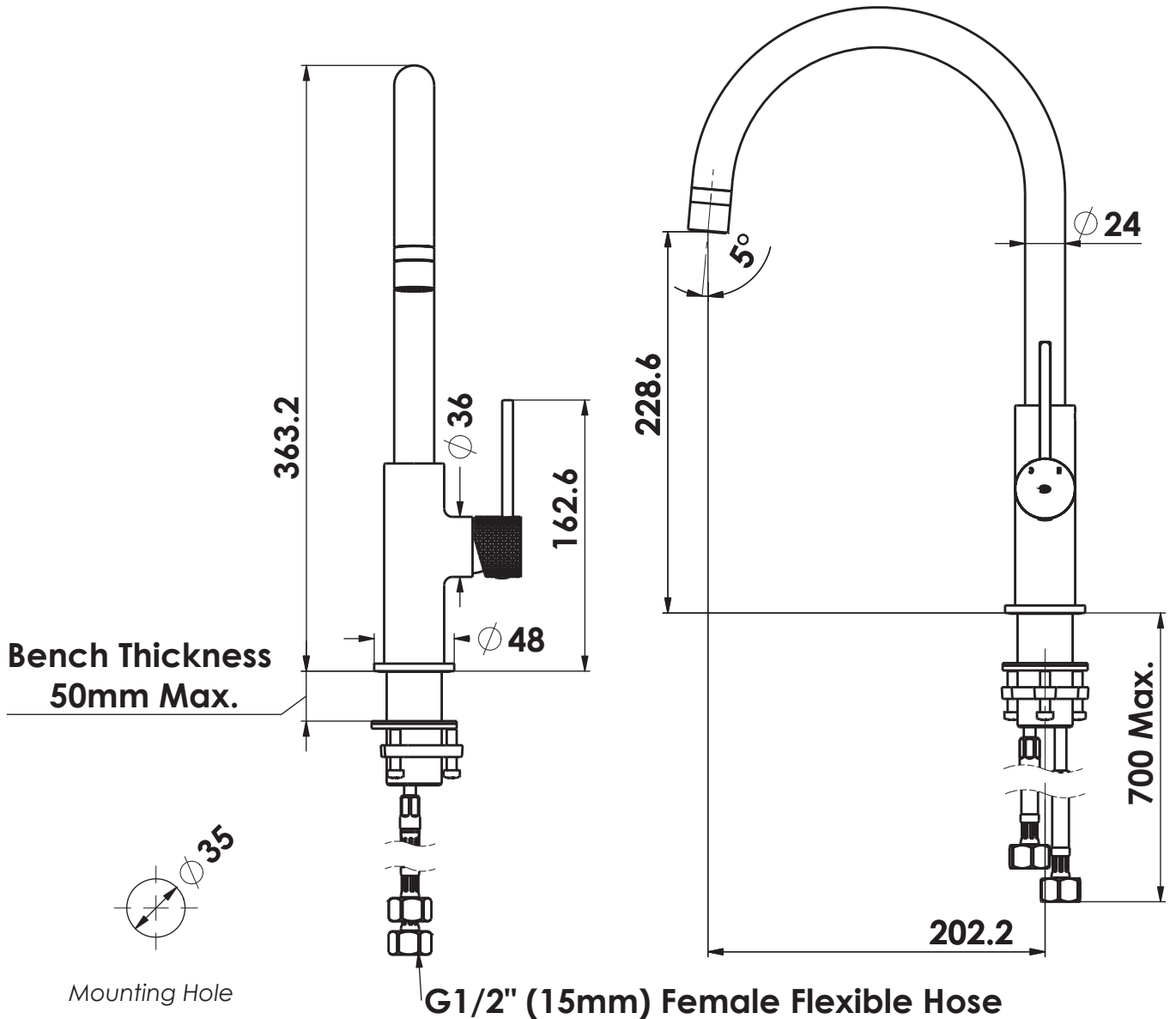

NZ PHONE - 0800 655 455
EMAIL - nzsales@greenstapware.com
WEBSITE - greenstapware.com

 | **GREENS**
where life meets water



MACI & MIKA SINK & BASIN MIXERS (For All Pressure Installations) **INSTALLATION INSTRUCTIONS**

PRODUCT #

BATCH #

ATTENTION PLUMBER

To ensure the optimum performance and customer satisfaction please adhere to the following:

- **Flush out all pipe work prior to installation.**
- Installation shall be in accordance with the AS/NZS3500 series of standards.
The maximum operating pressure within any building should not exceed 500kpa.
Pressure above 500kpa can cause damage from water hammer, reducing life of appliances, taps and fittings and cause excessive noise in the plumbing system.
- Pressure over 500kPa will require a limiting valve.
- Inline strainer / filter must be installed in the line before the mixer to cover both hot and cold supplies (not supplied). Must be accessible.

TECHNICAL DATA

- Minimum Water pressure for satisfactory operation: 35Pa
- Maximum Water pressure: 500kPa
- Maximum hot water temperature: 70°C
If the Water temperature exceeds 70°C an approved Tempering Valve must be fitted.
- The flow rate of the sink and basin mixers has been rated under the NZ Water Efficiency Labeling Scheme (WELS) to 5 Star — 6.0 litres per minute.

Please leave this form with the product once installed.

For full warranty terms and conditions, please see the warranty card enclosed with this product or visit www.greenstapware.com/warranty-and-care/

Distributed by: Greens Global Limited
PO Box 5055, Hamilton, 3200
22 The Boulevard, Te Rapa, Hamilton 3200
Phone: 07 849 0109, Fax: 07 849 0540
Website: www.greenstapware.com
Email: nzsales@greenstapware.com
Service Hotline: 0800 655 455

#42146 11/21

Sink Mixer

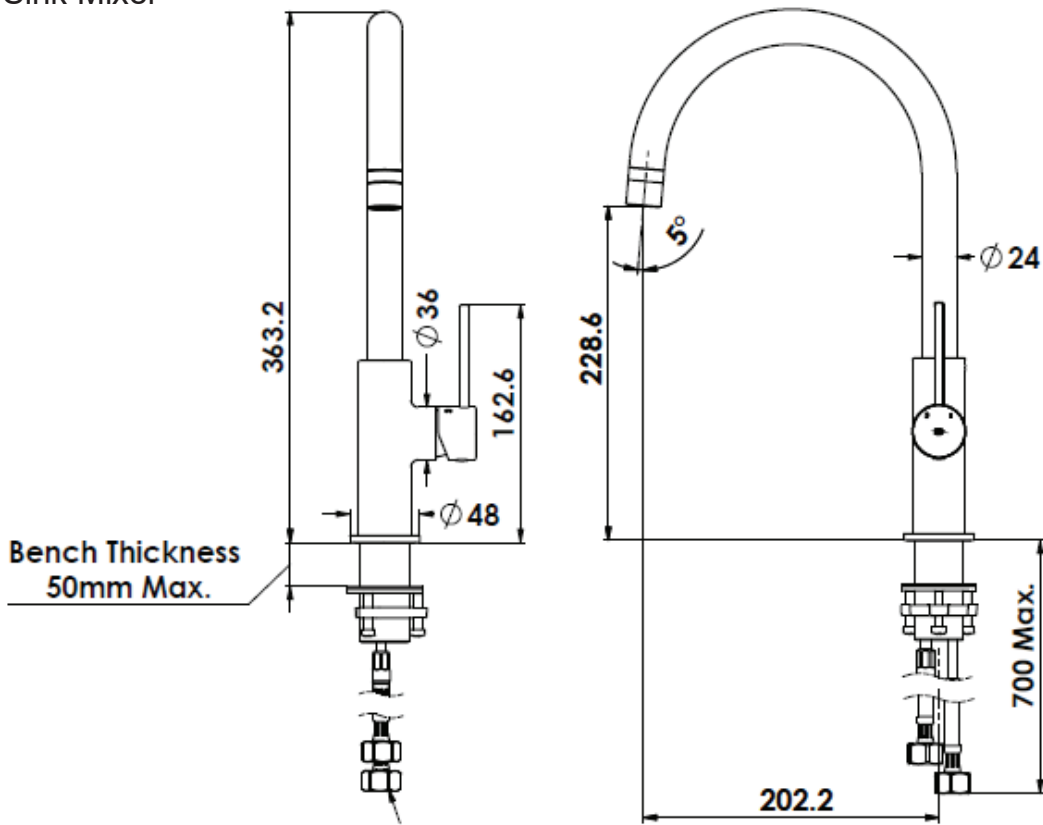

Bench Thickness
50mm Max.

G1/2" (15mm) Female Flexible Hose



Basin Mixers STD & Tower

Mounting Hole

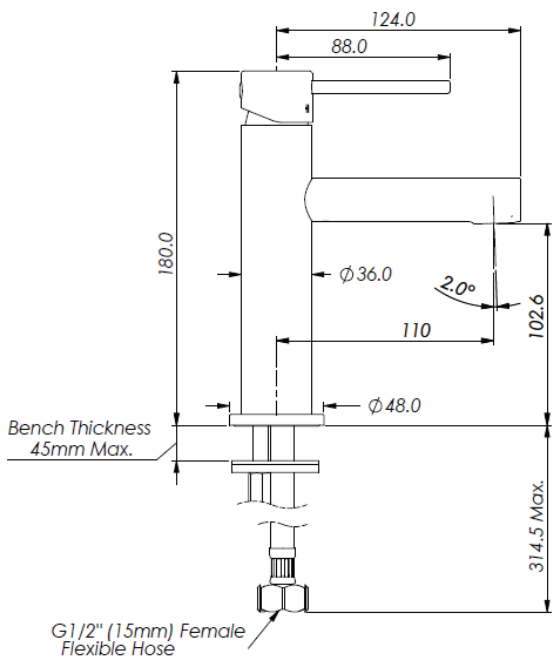

Bench Thickness
45mm Max.

G1/2" (15mm) Female
Flexible Hose

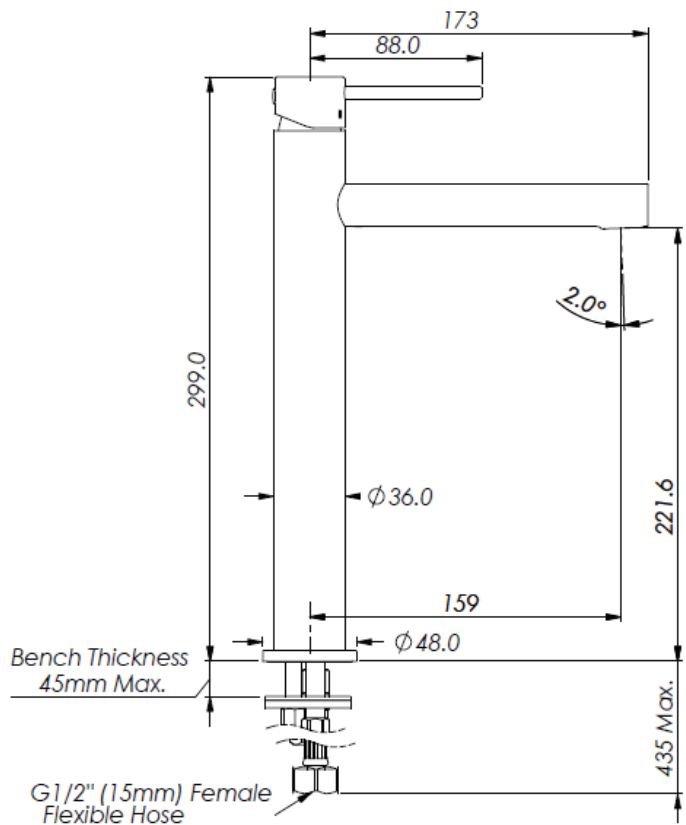

Bench Thickness
45mm Max.

G1/2" (15mm) Female
Flexible Hose

SINK MIXERS

Note: Fits Maximum Bench thickness of 50mm.

To install mixer, cut a mounting hole 35mm in diameter in the bench surface.

Equal pressure Installations only: Please remove non-return valve pre fitted to "Hot" water inlet hose (red braided hose).

1. Unscrew mounting nut and remove steel washer and rubber washer from threaded mixer tail. Ensure **seal** is sitting in groove at base of mixer.
2. Position mixer in bench top with the handle on the right.
3. From underneath the bench install the **rubber washer** then the **steel washer** and screw **mounting nut** onto threaded tail of mixer and **tighten the jacking screws**.
 - a. Screws may require backing off before installing nut.
4. Install inlet hoses:
 - a. Screw the "HOT" hose (red) and **hand tighten** into hot inlet (red) of mixer.
 - b. Screw the "COLD" hose (blue) and **hand tighten**, into cold inlet of mixer.
5. **Connect flexi hoses** to water supply.
 - a. Non-return valve must be fitted to hot inlet hose for unequal pressure (arrow for flow).
 - b. The union nuts must be connected to 15mm thread fittings which have a **machined end face with a chamfer, not "sawn off" threaded tube**.
 - c. **Do not over tighten the nuts**.
 - i. Hand tighten then 1/4 turn with spanner.
 - d. **Do not kink, stretch or twist**, any bends in the flexible hose should have radius of no less than 85mm.
6. Turn on water supply and **check for leaks**.

BASIN MIXERS

Note: Fits Maximum Bench thickness of 45mm.

To install mixer, cut a mounting hole 35mm in diameter in the bench surface.

Equal pressure Installations only: Please remove non-return valve pre fitted to "Hot" water inlet hose (red braided hose).

1. Unscrew mounting nut and remove steel washer and rubber washer from mounting thread.
2. Check the M8 **mounting thread is tight** into base of mixer.
3. Ensure **seal** is sitting in groove in the base flange of mixer.
4. Lower mixer with fitted hoses into the mounting hole and position mixer in bench top.
5. From under bench, install the **rubber washer** then the **steel washer** over mounting thread and screw the **mounting nut** to mounting thread.
Tighten with 11mm tube spanner and secure the mixer to the bench.
6. **Connect flexi hoses** to water supply.
 - a. Non-return valve must be fitted to hot inlet hose for unequal pressure (arrow for flow).
 - b. The union nuts must be connected to 15mm thread fittings which have a **machined end face with a chamfer, not "sawn off" threaded tube**.
 - c. **Do not over tighten the nuts**.
 - i. Hand tighten then 1/4 turn with spanner.
 - d. **Do not kink, stretch or twist**, any bends in the flexible hose should have radius of no less than 85mm.
7. Turn on water supply and **check for leaks**.

BENCH TOPS

- ◆ Formica/wooden bench tops, extra mounting support is required below the bench.
- ◆ Stainless steel bench tops ensure the mounting washer is against the S/Steel.
- ◆ **Vitreous china tops additional sealant maybe required at the base of the mixer to ensure a water tight seal.**

AERATORS

SINK MIXER - MAINS PRESURE Fitted with the dual spray aerator .



SINK MIXER - LOW PRESSURE Replace complete aerator.

1. Unscrew the dual spray aerator from the mixer outlet anti-clockwise at point shown in picture below.
2. Screw the low pressure aerator to mixer outlet, in by hand clock-wise, then a light nip up with a spanner.
 - a. Ensure washer is in place.



BASIN - MAINS PRESSURE

On mains pressure systems to achieve the WELS 5 star rating 6 l/m, the aerator at the end of the spout needs to be replaced.

Unscrew the aerator anti-clockwise and replace with the WELS rated aerator using the tool supplied.

