

## Trespa Pura NFC® Flush Cladding System, Vertical Installation

Make a facade drawing.

- We recommend you read the below instructions first to ensure correct placement of cladding and accessories.

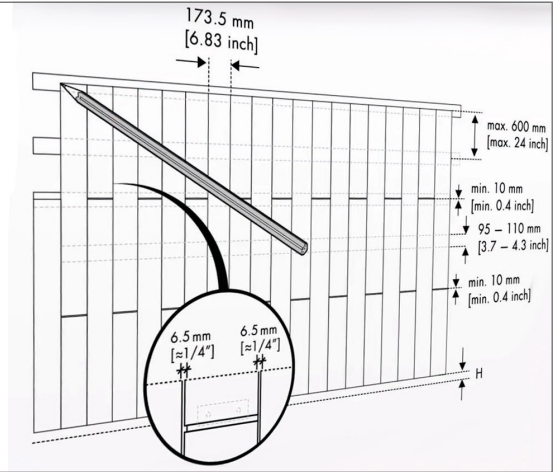

- Mount Vertical battens of 95-110mm width, minimum 34mm deep.
- Mount horizontal battens of 115-120mm width, with a minimum depth of 34mm.
- The maximum distance between the horizontal battens is 600mm on centre.
- Fix battens with flat head screws.
- It is essential that all battens are mounted in such a way that they provide a perfectly flat surface for the Pura cladding.

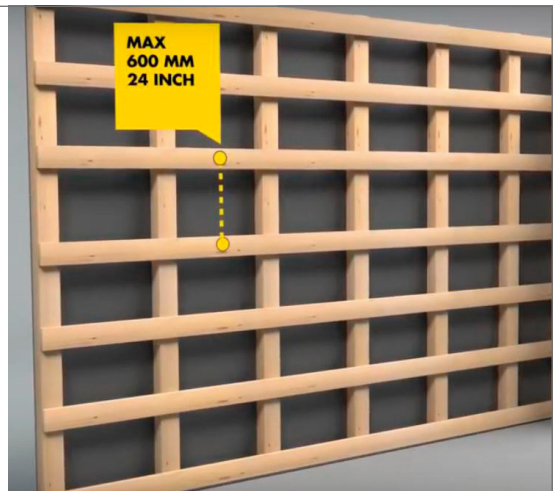

- The first horizontal batten should be placed 5mm from the ground.



- Ensure there is sufficient space behind the vertical battens for natural ventilation.

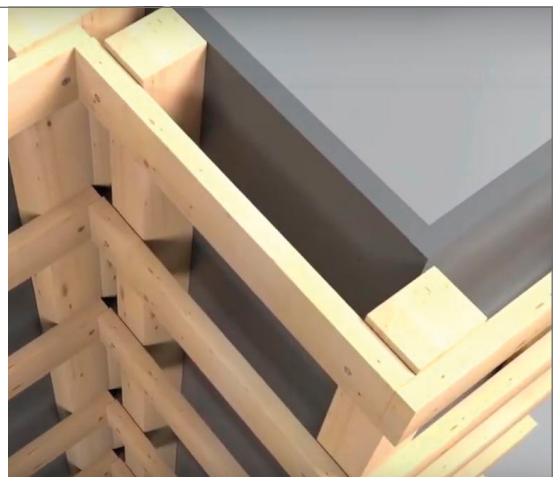

- Attach strips of **EPDM Rubber Gasket** at least as wide as the horizontal batten.

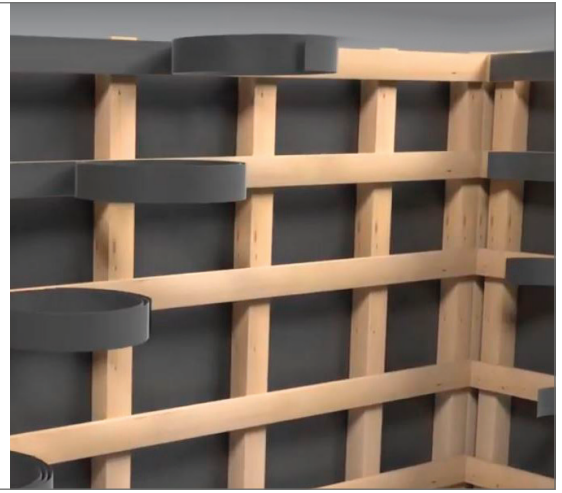

- Fit **Finish Profiles** and **Outer Corner Profiles** at appropriate places on your cladding framework.
- Fix the profiles with a **SFS Intec Profile Screws** along the length of the profile.

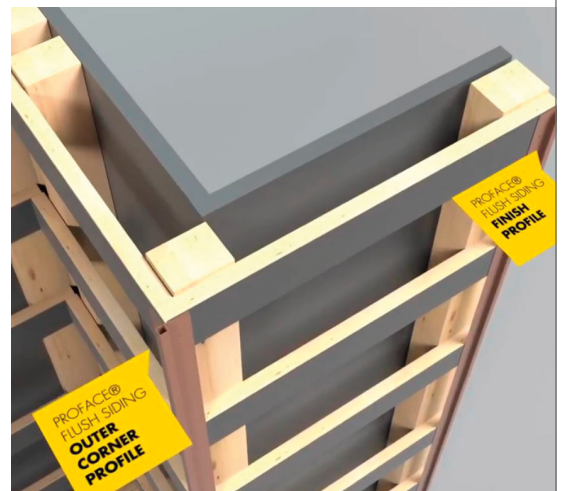
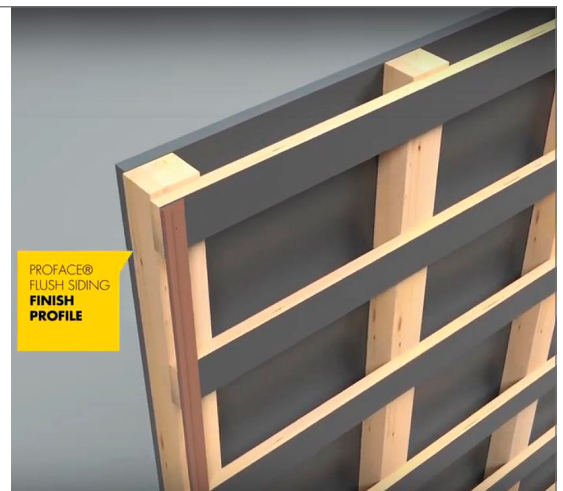

- Place a **Support Profile** on the first batten.

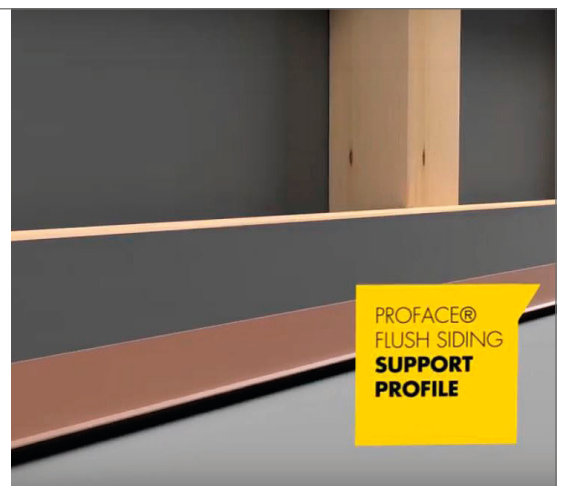

- Fix a **Universal Clip** as illustrated - note the clip positioning.

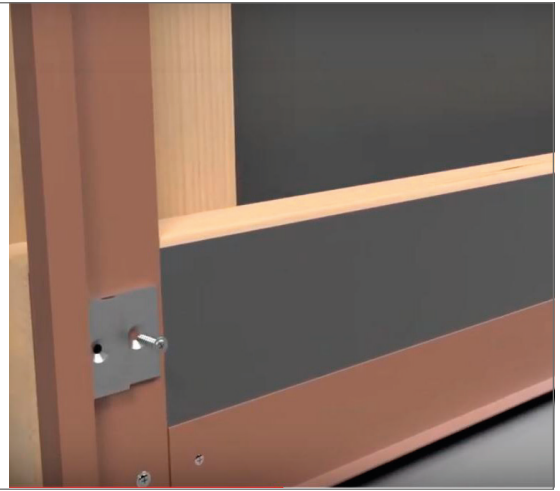

- Ensure any inner joints (where 2 vertical planks would meet) are in the middle of the horizontal batten, allowing sufficient space for the Universal Clips below and above the joint.



- Cut the cladding plank to size.
- Cut a **Support Profile** to 100mm length and secure above the cladding plank. Ensure there is an 8mm clear gap between the plank edge and the support profile.



- For the next vertical column of cladding planks, allow an expansion gap of 1mm between the edge of the plank and the next Universal Clip.
- Note the clip positioning.

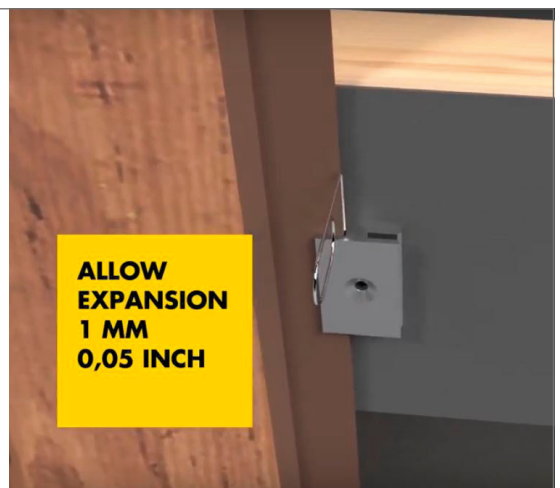

- Place the remainder of the cladding planks up to the corner or edge.



- For the corners, cut a cladding plank to size.

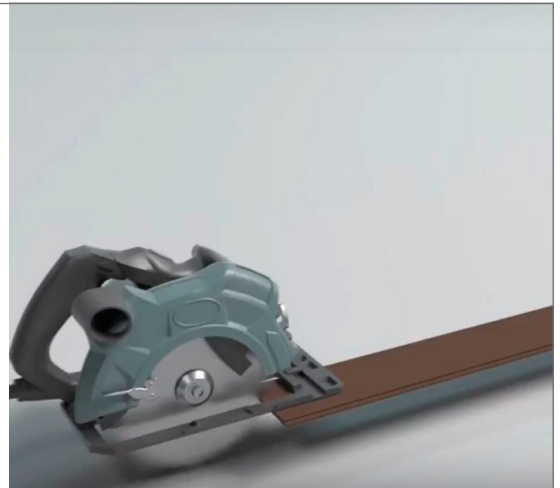

- Drill 8 mm holes at least 20 mm from the top of the siding.
- Drill 8 mm holes at least 20 mm from the side of the cladding/horizontal batten.

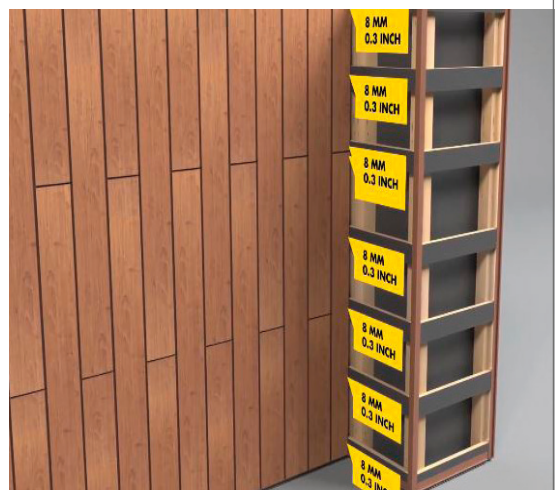

- Fix the cladding with **SFS Intec HPL Fast Fixing Screws**.



- If a roof trim is used to finish your installation, leave a 5mm gap between the top of the cladding planks and the trim.



*This document is intended to provide guidelines for informational purposes only. We strongly advise that the customer, project owner and architect seek independent advice from a certified construction professional and/or engineer regarding application and installation as well as compliance with design requirements, applicable codes, laws and regulations, and test standards. Please check your local codes and applicable design requirements for proper use.*

*For current product/technical information see [www.trespa.info](http://www.trespa.info)*

## Questions?

Please contact Performance Panels Limited on:  
01422 310 319

Alternatively email us on:  
[info@performance-panels.co.uk](mailto:info@performance-panels.co.uk)



performance panels

[www.performance-panels.co.uk](http://www.performance-panels.co.uk)