

*ew*  
ELITE WATER  
SYSTEMS

# 3 STAGE WHOLE HOUSE WATER FILTERING SYSTEM

Powered by



## TITANIUM LT

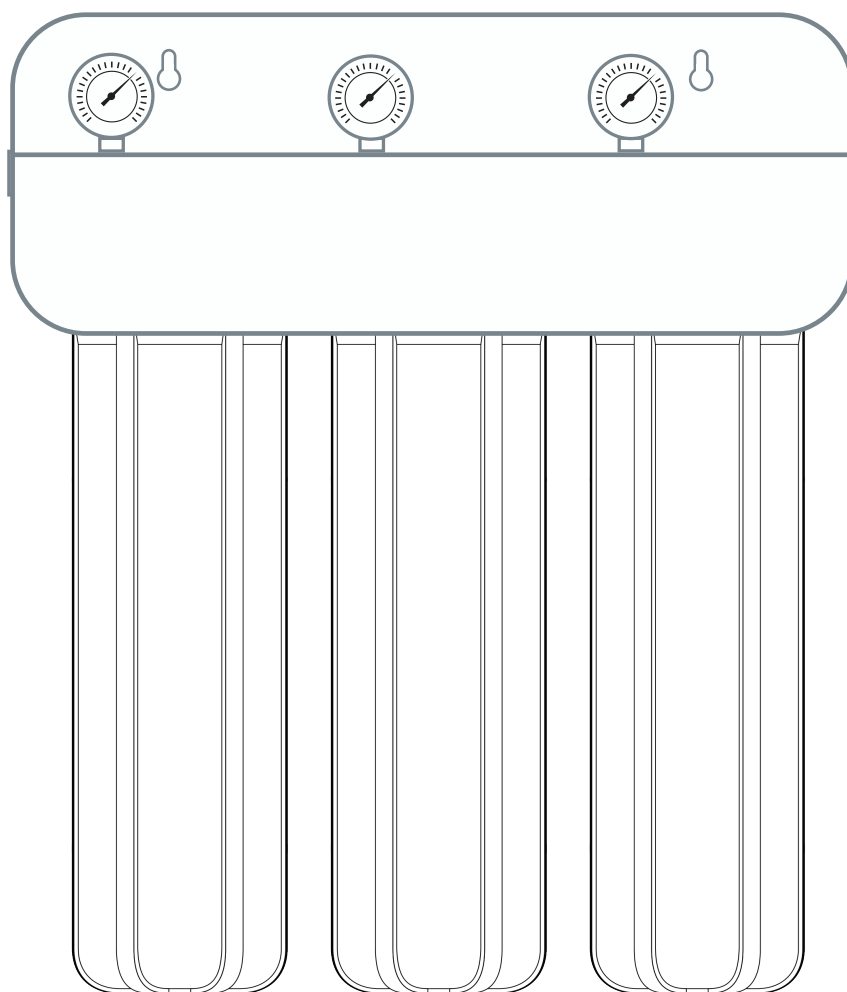

### PROFESSIONAL INSTALLATION, OPERATING AND SERVICE MANUAL



Components certified by IAPMO R&T to NSF/ANSI 42, 61, 372 - lead free, CSA B483.1. In compliance with Drinking Water Treatment Units regulations, USA and Canada.



## TABLE OF CONTENTS

1	Safety Alert Symbols	2
2	General Information	2
3	Personnel's Qualification	3
4	Precautions, Warnings	3
5	Installation	3
6	Start Up	4
7	Use	4
8	Spare Parts	5
9	Cartridge Replacement	6
10	Maintenance	7
11	Troubleshooting	7
12	Filter and Cartridge Disposition	7
13	LIMITED WARRANTY	7

### 1 - Safety Alert Symbols

#### **WARNING**

**WARNING SIGN:** indicates a potentially hazardous situation which, if not avoided, could result in death or serious injury. It highlights conditions that are a serious risk for personal safety.

#### **CAUTION**

**CAUTION SIGN:** Indicates a potentially hazardous situation which, if not avoided, may result in a minor or moderate injury, and to alert against unsafe practices.

#### **NOTICE**

**NOTICE SIGN:** Alerts you to pertinent facts and conditions.

### 2 - General Information

#### **CAUTION**

**PLEASE READ THIS INSTRUCTIONS MANUAL THOROUGHLY AND CAREFULLY AND UNDERSTAND ITS CONTENTS BEFORE INSTALLING THE ELITE WATER SYSTEM FILTER HOUSING.**

- *The information in this instruction manual is subject to modifications without prior notice and is not binding on the manufacturer Elite Water Systems*
- *Keep the instruction manual for future reference.*

**Product Identification:** A label carrying product identification, serial number, production batch is applied on the package of the product. An additional label describing maximum working pressure and maximum working temperature is applied to the filter housing.

The label must not be removed, tampered, hidden, covered, or changed.

If the label on the product is missing or the operational conditions on the label are not legible, **DO NOT INSTALL** the filter and contact Elite Water System Dealers or contact at 210-556-5452.

#### **WARNING**

**The values of the maximum working temperature and the maximum working pressure shown in the label affixed to the filter housing are intended as maximum working parameters and must not be exceeded under any circumstances.**

The filter cartridge intended to operate with this filter housing may not be included in the package and, if not included, must be purchased separately. Carefully choose the filter cartridge fit for the selected filter housing in the literature and pamphlets made available by Elite Water System Dealers.

Use only original Elite Water System Filter Cartridges. The use of cartridges different from the original ones voids the warranty.



### 3 - Personnel's Qualification

ONLY QUALIFIED AND LICENSED PERSONNEL MAY PERFORM INSTALLATION, SERVICE AND MAINTENANCE OF THE ELITE WATER SYSTEM FILTERS.

### 4 - Precautions, Warnings

READ ALL INSTRUCTIONS AND PRECAUTIONS BEFORE INSTALLING AND USING YOUR ELITE WATER SYSTEM PRODUCT.

#### WARNING

-  Before installation ensure that any electric plugs in the vicinity of the area are disconnected.
-  Do not install near electric appliances.
-  Do not use with water that is microbiologically unsafe or of unknown quality without adequate disinfection before or after the system. Systems certified for cyst reduction may be used on waters that contain filterable cysts.

#### CAUTION

Turn-off the water main before installation.

### 5 - Installation

Refer to Fig. A, B and C for installation directions.

- Before installation, check if the plumbing system has been set-up according to the applicable plumbing code.
- Avoid all kinds of tensions by using an Elite Water System wall bracket, accessory available on demand. Should the use of the wall bracket be impossible, the installer (qualified and licensed personnel) shall be responsible for the most appropriate installation avoiding tensions which may affect the filter's integrity.
- Connect the inlet to the product's side with the arrow IN and the outlet to the side with the arrow OUT. (Fig. B)
- Connect to pipes using tapered (conical) fittings ONLY in the case of NPT marked housings and/or in the case of housings specified as NPT in the label affixed in the package of the product. Three-quarter (3/4) "Sharkbite" X 1" male reducing adapter (lead free) recommended or a 3/4 "Sweat" X 1" male reducing adapter. Preferably connect to pipes using flexible hoses.
- Connect to pipes using BSP (cylindrical) fittings in the case the housing is not marked NPT or not specified as NPT in the package label.
- Preferably connect to pipes using flexible hoses.  
Use only sealing tape as a sealant for the connections.
- The installation of a By-pass is recommended (see Fig. A).  
If the housing is provided complete with cartridge, remove the protective plastic wrap from the cartridge before the use.
- Refer to Fig. pag. 6 section 9 below for step-by-step instructions for the insertion of a (new) cartridge.

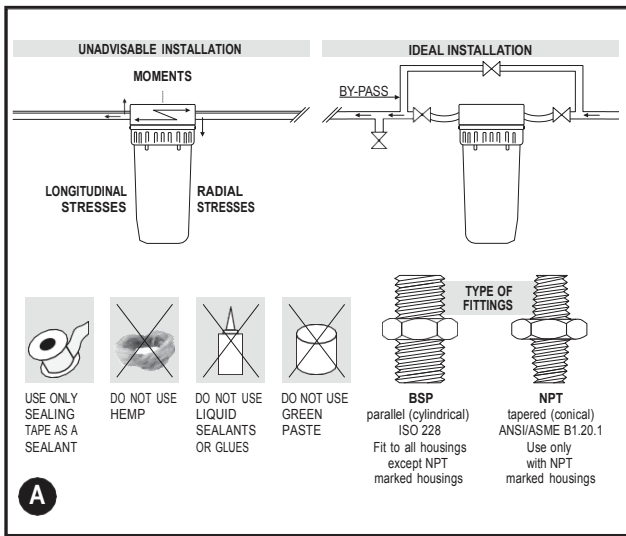

## Modes for presentation of inlet and outlet directions (arrows) in different filter housings models

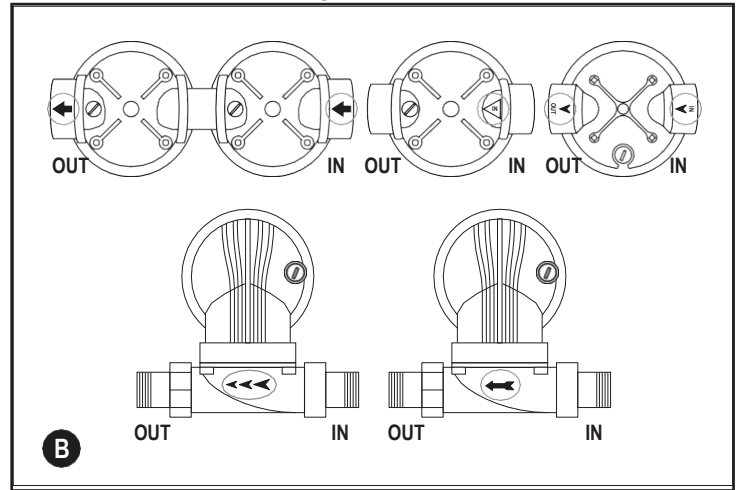

### 6 - Start Up

- Keep the Filter package with label affixed to identify the product.
- Ensure that the sealing is tight and secure.
- After the installation, run the tap and let the water flow for at least 5 minutes before use.

#### CAUTION

The initial quality of the water will not be optimal unless the tap runs for at least 5 minutes before use.

### 7 - Use (check the label on the package to identify the filter housing series and model)

- Refer to Figure C for installation layout.
- Three Piece and Big filter housing with plastic threaded connections are certified against NSF/ANSI Standards 42 and 61 for the filtration of drinking water. In case of use for the filtration of drinking water, do not use for filtration of water that is unsafe or of unknown quality. Systems certified for cyst reduction may be used on waters that contain filterable cysts.
- Check for the filter housing model from the label applied on the product package and from the legend (Sticker Legend) printed on the package.
- Respect the working parameters shown in the package data plate and in the label affixed to the filter housing.
- If pressure exceeds the working conditions, protect the product with a pressure reducer.
- Keep transparent (clear) filter housings models protected from light. Use only opaque (blue) housings models for installation under direct light. Filter housings with designations transparent and opaque must be supplied with cold water only.
- Use Reinforced Polypropylene (Big) filter housing models only for water with pH not applicable for drinking water (check for national/local regulations). Reinforced Polypropylene filter housings must be supplied with cold water only. Keep Reinforced Polypropylene filter housings models protected from light.
- Use only HOT filter housing models for hot water filtration (applicable working temperature on product's label).
- Protect from excessive cold or heat: do not expose to temperature below 39°F (4°C) or above 113°F (45°C) all housings models with the only exception of HOT model which can stand up to 176°F (80°C).
- Protect from back-flows of hot water (except for HOT models within working parameters) with a non-return valve.
- Protect from hammering with an anti-hammering device.
- Should the filter (housing + cartridge) be left not in use for more than 1 week replace cartridge/s with new one/s prior to use.

## CAUTION

 The values of the maximum working temperature and the maximum working pressure shown in the label affixed to the filter housing are intended as maximum working parameters and must not be exceeded. Use of the filter housing under higher pressure conditions could cause ruptures.

## WARNING

Use Three Piece and Big filter housing models for filtration of drinking water.

### INSTALLATION LAY OUT

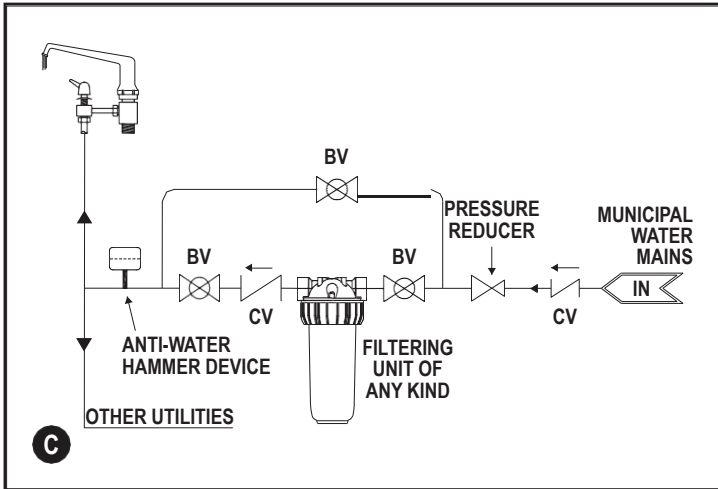

CV = Check Valve, BV = Ball Valve

Titanium LT - Sediment/Phosphate/CTO Carbon Block	
Chlorine	•
Chlorine bi-products (VOCs)	•
Pesticides	•
Herbicides	•
Phosphate	•
PFOS	Reduction
PFAS	Reduction
PFOA	Reduction
PFNA	Reduction
Pharmaceuticals	•
Microplastics	•
Chloramines	Reduction
Nitrate	Reduction
Microbial Cyst Antimicrobial Technology	•

Reduction & Removal to NSF/ANSI Standard

Titanium LT - Sediment/Phosphate/CTO Carbon Block													
IAPMO Certification Claims	Certification Description	Class Level	Service Flow Rate GPM	Water Pressure		Pressure Drop	Temperature		Filter Capacity/Replacement Interval Gallons	Weight LBS	Dimensions (In.)		
				Min	Max		Min	Max			Height	Width	Depth
System			7	40	120	12	40	100	120,000	Empty: 30-35 Full: 70-75	29.25	23.5	9
Sediment Filter NSF 61, 42	Health Effects, Sediment removal	IV	7	40	120	12	40	100	120,000	2	20	4.5	
Phosphate Filter NSF 61, 42	Phosphate & Anti-scale		7	40	120	12	40	100	120,000	3	20	4.5	
CTO Carbon Block Filter NSF 61, 42	Chlorine, Taste Odor removal		7	40	120	12	40	100	120,000	7	20	4.5	

\* Replacement filter requirements depend on quality of incoming water. Typically every 12 months.

\* Clearance needed for filter replacements - 8" from the bottom of the unit.

## 8 - Accessories, spare parts and filter cartridges

Accessories, spare parts and filter cartridges are available through the Elite Water System Dealers. In case of difficulties contact Elite Water System at 210-556-5452.

## NOTICE

Use only original Elite Water System Filter Cartridges. The use of non-original Elite Water System cartridges voids the warranty.

## 9 - Operations for Filter Cartridge replacement

### NOTICE

If the filter cartridge is not included in the package it must be purchased separately.

See figures and follow step-by-step instructions below to replace the filter cartridge.

Refer the literature and pamphlets made available by Elite Water System Authorized Dealers or the label in the Filter Cartridge's plastic wrap/package, to determine the appropriate Elite Water System cartridge. In choosing the filter cartridge fit for the purpose follow the indication and recommendations available from the cartridge wrap/package. The average life of a filter cartridge varies depending on use, environmental conditions, pressure, etc. In general, changes in taste, odor, or color in the water indicate that the cartridge should be replaced. The use of non-original Elite Water System cartridges voids the warranty.

- A. Before opening the filter housing turnoff the water main (1) and place a tray under the system to catch any water spilling during the removal of the filter cartridge;
- B. Release the pressure from the product by un-screwing the vent-valve of the head (2).
- C. Open the housing unscrewing the housing (3). the housing unscrewing the housing (3).
- D. Remove the used cartridge (4).
- E. Wipe clean the filter housing with cold water and a soft sponge.
- F. Open the new cartridge wrap and discard wrap (5).
- G. Insert the new cartridge and place it into the housing (6).
- H. Tighten the housing bowl to housing's head using the wrench (7). If the wrench is not included in the package it must be purchased separately. Do not over-tighten.
- I. Turn-on the water main (8).
- J. Slowly turn on the water supply;
- K. Wait for air purge from the vent-valve, then turn and tighten the vent-valve (9).
- L. Let the water flow for at least 5 minutes before use (10).

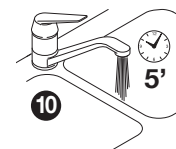
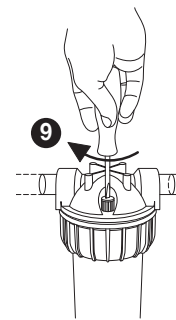
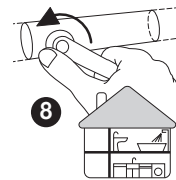
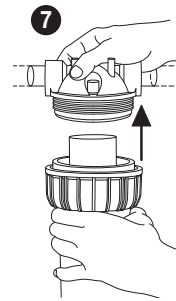
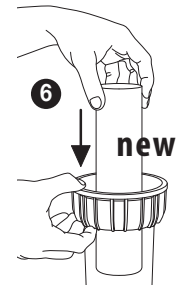
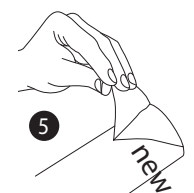
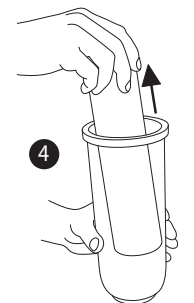
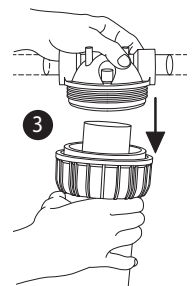
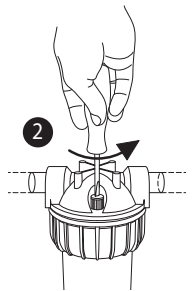
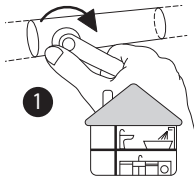

## 10 - Maintenance

- Replace the filter housing bowl at least every 5 years.
- For maintenance and replacement of filter cartridges follow the instructions on the filter cartridge wrap/package.
- If not in use for more than 1 week remove the filter cartridge, and restart operating per the maintenance/replacement procedure indicated on the filter cartridge wrap/package.

### **CAUTION**

After carrying out maintenance operations, run the tap for at least 5 minutes before using the water.

## 11 – Troubleshooting

MALFUNCTION	CAUSE	REMEDY
Leaks between housing and housing head.	a.Housing not sufficiently tightened. b.O-ring affected/old.	a.Tighten further the housing with the wrench. b.If the housing still leaks, change the housing's O-ring with a new one (use original replacement / spare parts).
Leaks in inlet / outlet connections.	a. Not enough sealant and/or connection not sufficiently tightened. b. Improper connection type.	a.Remove the previous sealing tape from the fitting and place more sealing tape and or tighten the connection properly. b.Use only filters that match the type of fittings as indicated on the sump head. NPT tapered (conical) fittings fit only to Filters with NPT indication on the sump head.BSP parallel (cylindrical) fittings fit only to Filters without NPT indication in the data plate.

## 12 - Filter Housing and Cartridge Disposition

Filters housings and used filter cartridges must be disposed of in accordance with applicable rules and regulations.

## 13 - Limited Warranty

Limited Warranty/Products Warranty Elite Water System warrants to the original purchaser ("purchaser") that the following products will be free of defects of material and workmanship when sold for the time period listed for each product as follows:

Elite Water System warrants new Elite Water System products to be free from defects of material and workmanship for a period of 1 year (12 months) of service, if the 1 year of service falls within 24 months from date of manufacture.

Cartridge Type Filter (cartridge excluded) - 1 year from date of installation.

If a product fails to function within the stated time period, Elite Water System will remedy the defect. The purchaser shall immediately notify Elite water System of any defect. If the purchaser does not notify Elite Water System of such defects within the applicable Warranty Period, Elite Water System shall have no further liability or obligation to purchaser therefore.

After notifying Elite Water System of a defect and receiving permission and an Authorization Number to return the product, the purchaser may return the product to Elite Water System (freight pre-paid by purchaser) for repair and/or replacement. If Elite Water System determines that the warranty has not been breached, the product shall be repaired or replaced, at Elite Water Systems sole option, free of charge. In the event Elite Water System determines that it is unable to correct a defective component part or product, Elite Water System may, at its sole option, provide purchaser with a full refund or merchandise credit in the amount of the purchaser's price of purchase.

The foregoing limited warranty does not cover failure to function caused by damage to the product while in purchaser's possession, improper installation, unreasonable use or abuse of the product, failure to provide or use of improper maintenance failure to follow written installation and use instructions, neglect, accident, or maintenance of products which have been altered or repaired by any person receiving such product during the warranty period. (Continued on next page)



Elite Water System will also not be responsible for any damage or losses, direct or indirect, arising from any cause whatsoever, nor for damage to or modification, abrasives, corrosion, and/or electrolysis improper voltage supply, lightning or careless handling; nor for labor, transportation or other damages incurred in the replacement or repair of defective parts. In these cases repair will be subject to reconditioning charges in effect at the time.

THE REMEDIES PROVIDED IN THE PREVIOUSLY EXPRESSED LIMITED WARRANTY ARE THE SOLE AND EXCLUSIVE REMEDIES AVAILABLE TO THE PURCHASER. NO OTHER EXPRESS WARRANTIES ARE MADE. ALL IMPLIED WARRANTIES, INCLUDING BUT NOT LIMITED TO ANY IMPLIED WARRANTY OF MERCHANTABILITY OR FITNESS FOR A PARTICULAR PURPOSE OR USE, ARE LIMITED IN DURATION AS SET FORTH ABOVE. IN NO EVENT SHALL ELITE WATER SYSTEM BE LIABLE FOR ANY INCIDENTAL OR CONSEQUENTIAL DAMAGES. Some states do not allow limitations on how long an implied warranty lasts or do not allow the exclusion or limitations of incidental or consequential damages, so the above limitations or exclusions may not apply to purchaser. This warranty gives purchaser specific legal rights and purchaser may also have other rights which vary from state to state. The purchaser must maintain proof of purchase of the product to prove date of purchase in the unlikely event of a warranty claim.

**NOTICE**

We recommend that before installing a water filtration system you have the water tested to determine actual water filtering needs.

**NOTICE**

If the filter housing is provided without filter cartridge it can be selected in the literature and pamphlets made available by Elite Water System Authorized Dealers.

**NOTICE**

Use only original Elite Water System Filter Cartridges. The use of non-original Elite Water System cartridges voids the warranty.

**MAINTENANCE DATA COLLECTION**

DATE	TYPE OF MAINTENANCE

**NOTES**

---



---



---



---



---