

Uppeal Standing Desk

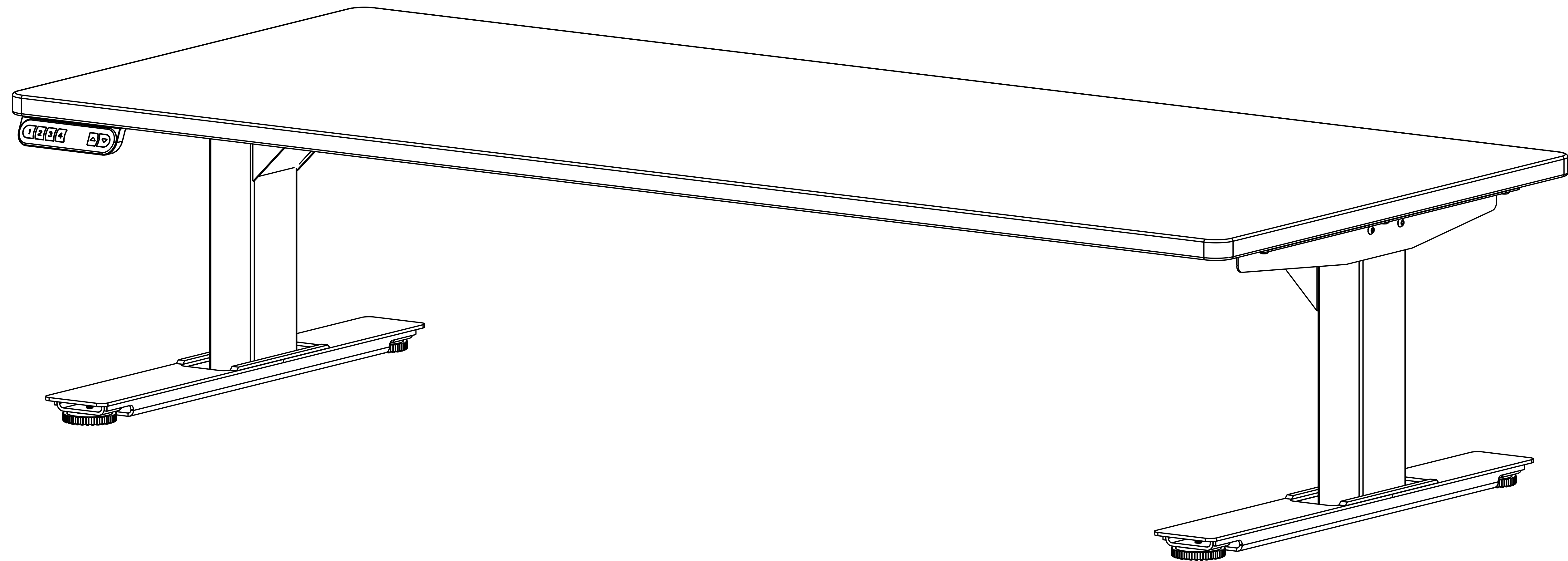

Designed and Assembled in Brooklyn, NY
Support: info@uppealdesign.com or visit uppealdesign.com

Patent pending, 2023, Uppeal Design Co., All Rights Reserved

Uppeal

Thank you for choosing Uppeal!

Use, Liability & Cautions

Please read this manual carefully.

Max recommended tabletop width: 80"

Max recommended tabletop depth: 40"

Min recommended tabletop thickness: 1.0"

Make sure there are no objects will interfere or impede the up/down movement of the desk when in operation.

Ensure all cord lengths are long enough to allow for full up/down movement of the desk when in operation.

Keep children away from desk.

Do not sit or stand on the desk frame. Do not crawl or lie under the desk frame.

Do not open or modify any of the components, including the Legs, Control Panel, Control Box. Doing so risks electric shock and voids any warranty claims.

Placing objects taller than 12" underneath the desk will obstruct the desk's movement and may result in physical damage.

Using a voltage converter could cause damage to the desk and is considered improper use. Resulting damage is not covered by the warranty.

Uppeal desk has electric motors and is designed for use in dry, room temperature work environments only.

Any use of this desk that is outside of the original design intent as a floor sitting to standing work surface is at user's own risk.

Under no circumstances does the manufacturer accept warranty claims or liability claims for damage caused by improper use or handling of the desk frame.

Tools Needed

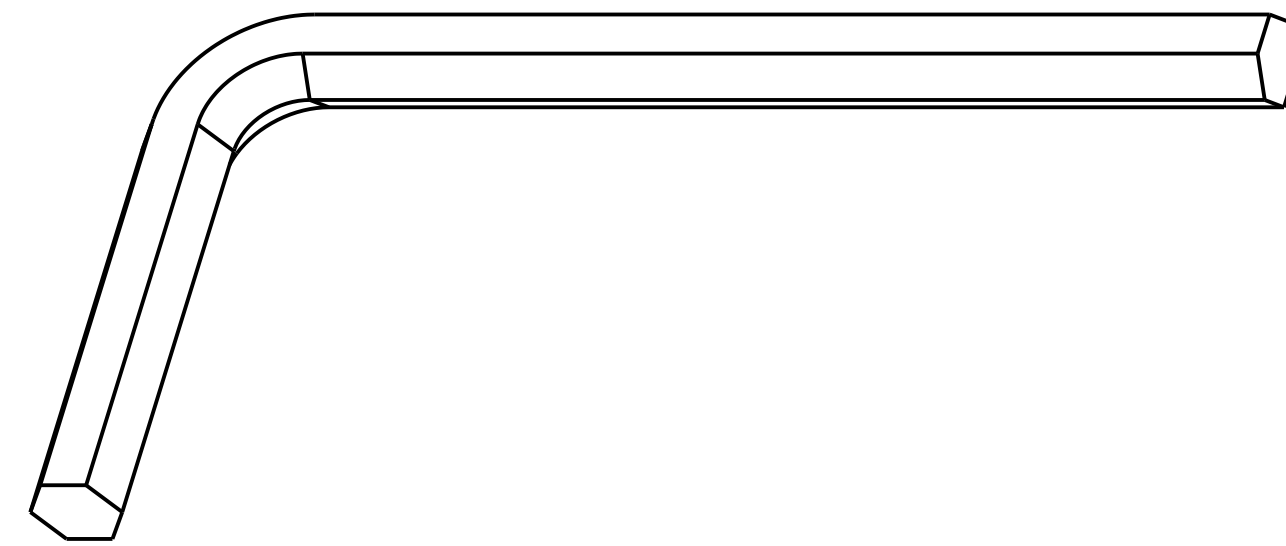

4mm L-KEY

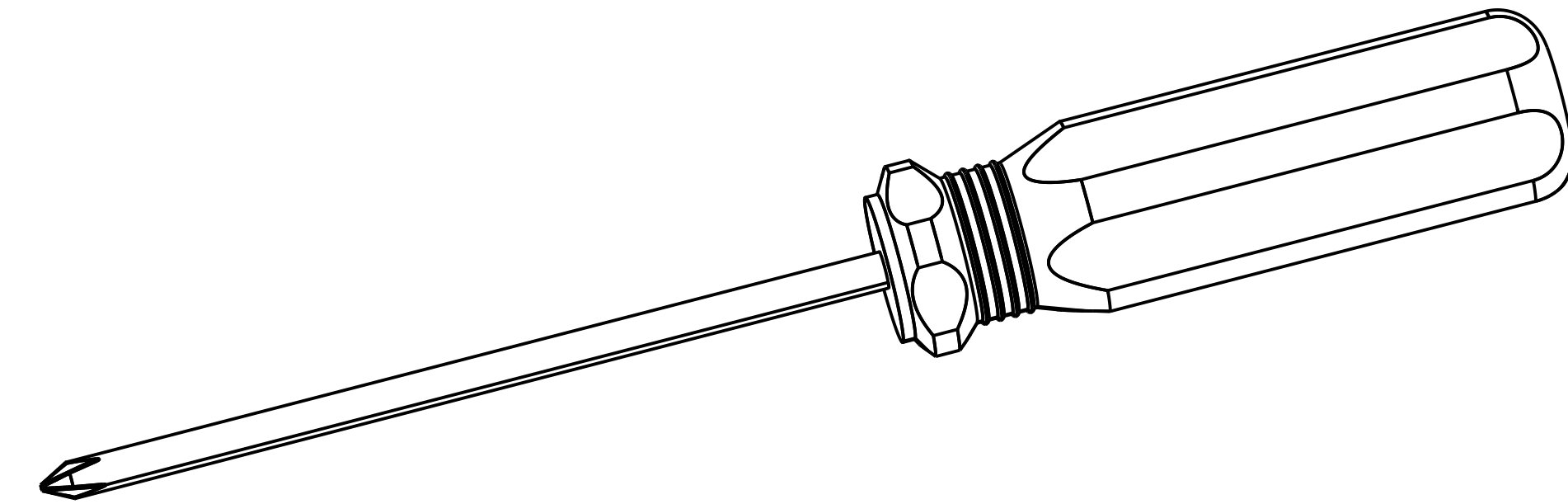

PHILLIPS HEAD SCREW DRIVER
(NOT PROVIDED)

2-Person Assembly Assemble on Soft Surface

Questions? Email Us!

info@uppealdesign.com

Parts List

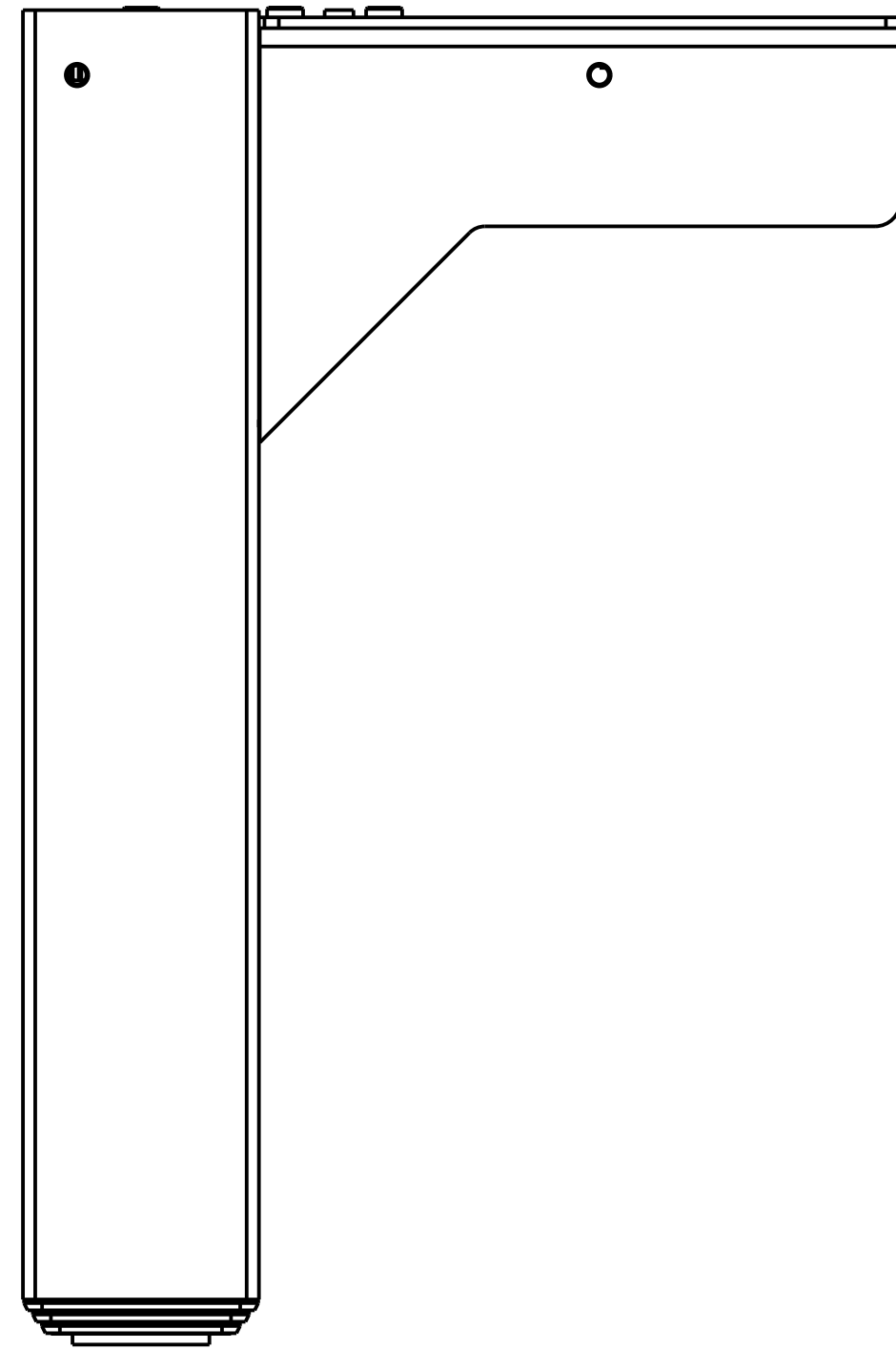

2x LEG

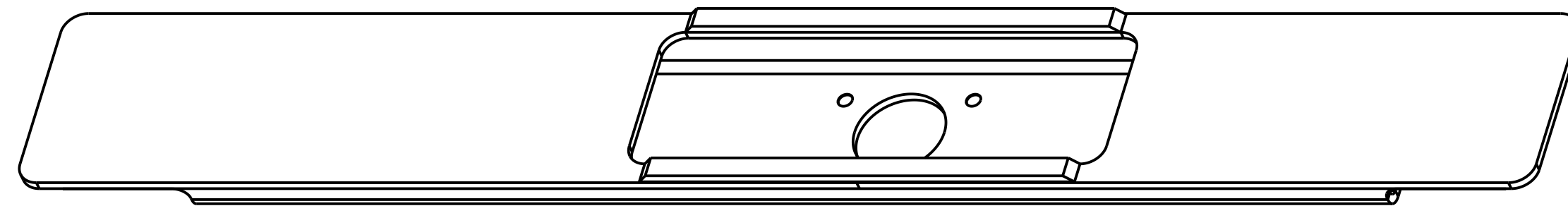

2x FEET

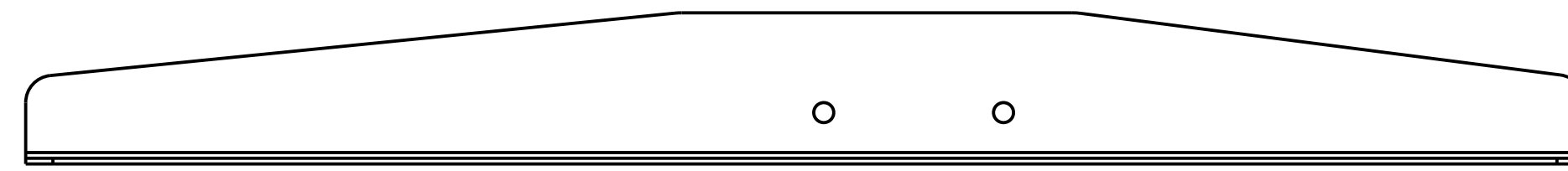

1x L-BRACKET LEFT

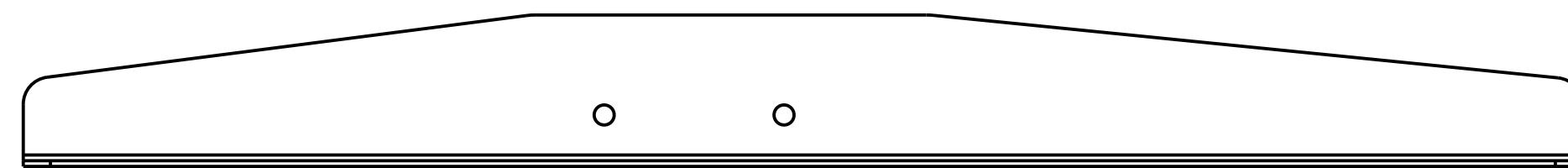

1x L-BRACKET RIGHT

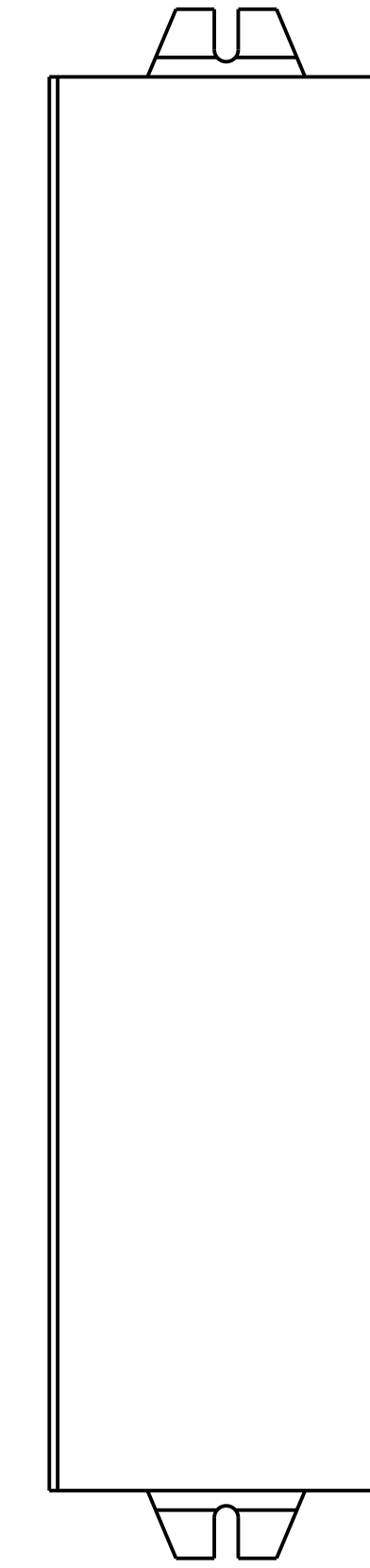

1x CONTROL BOX

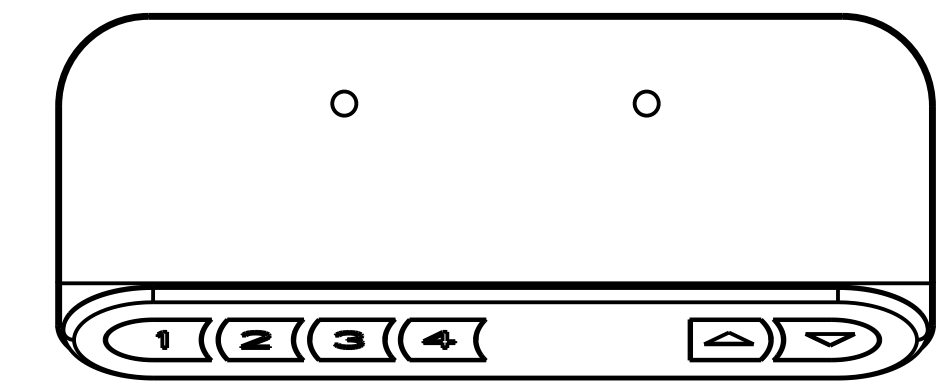

1x KEYPAD

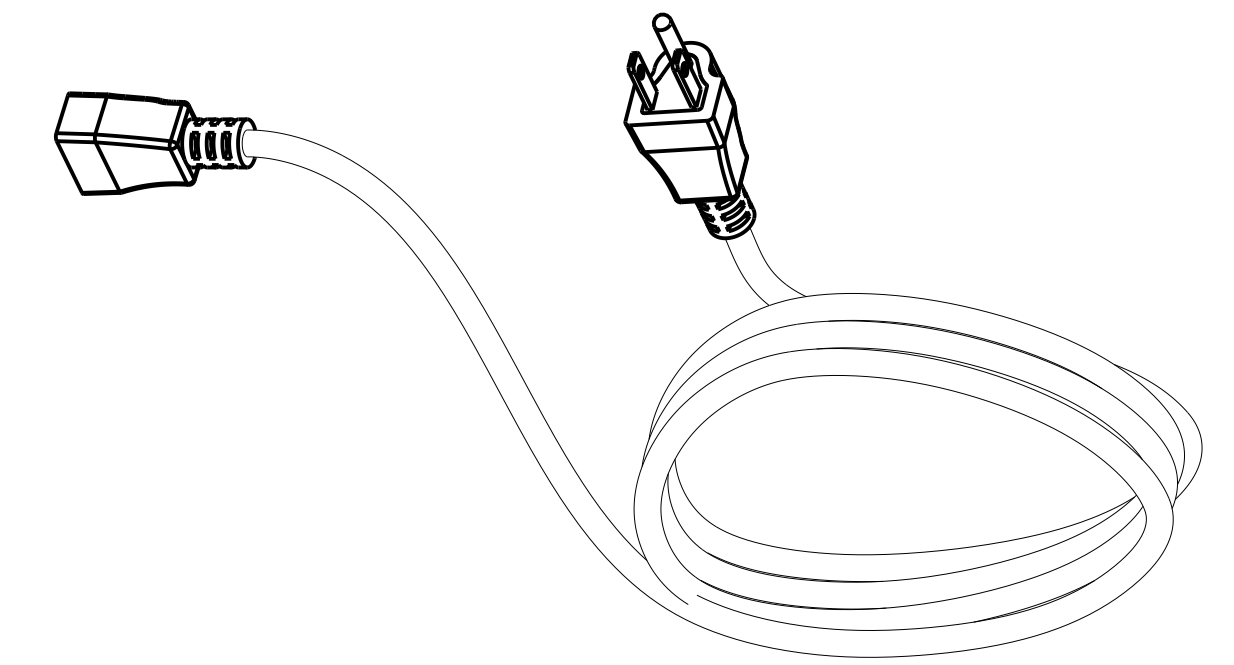

1x POWER CABLE

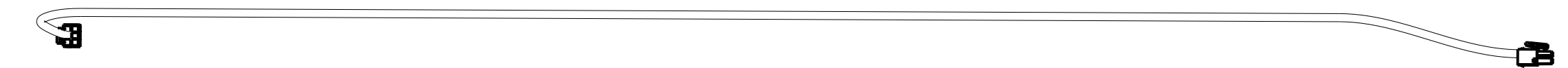

2x LEG CABLE

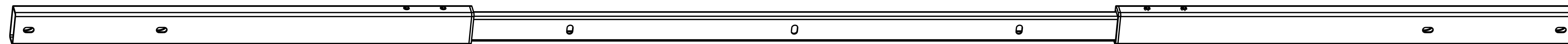

2x CROSSBAR ASSEMBLY

Hardware List

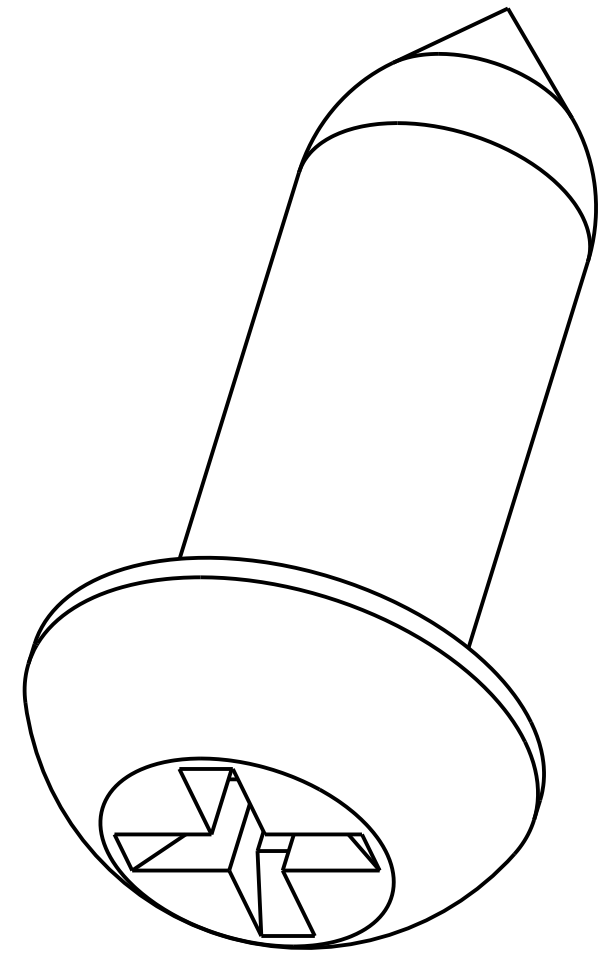

10x FB1

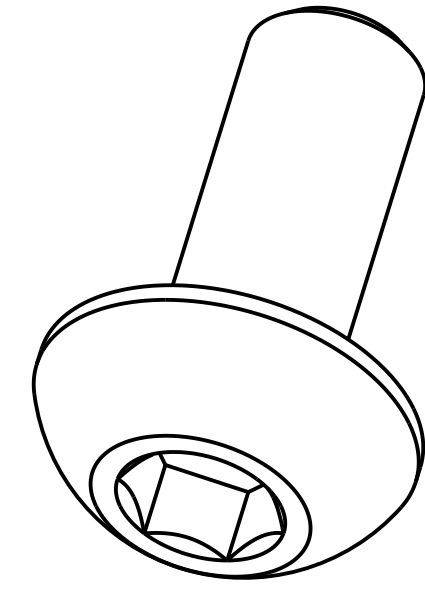

12x FB2

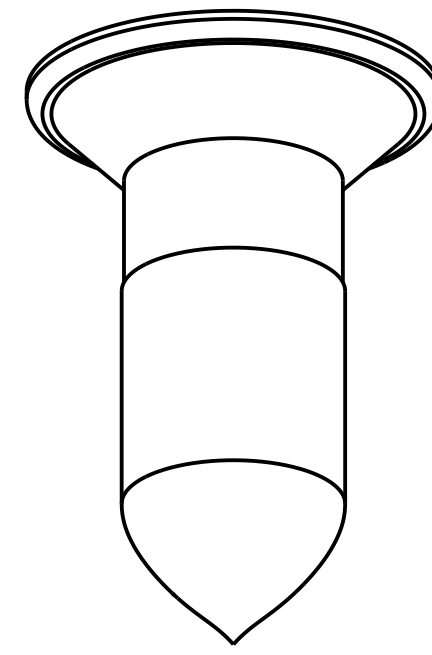

2x WS1

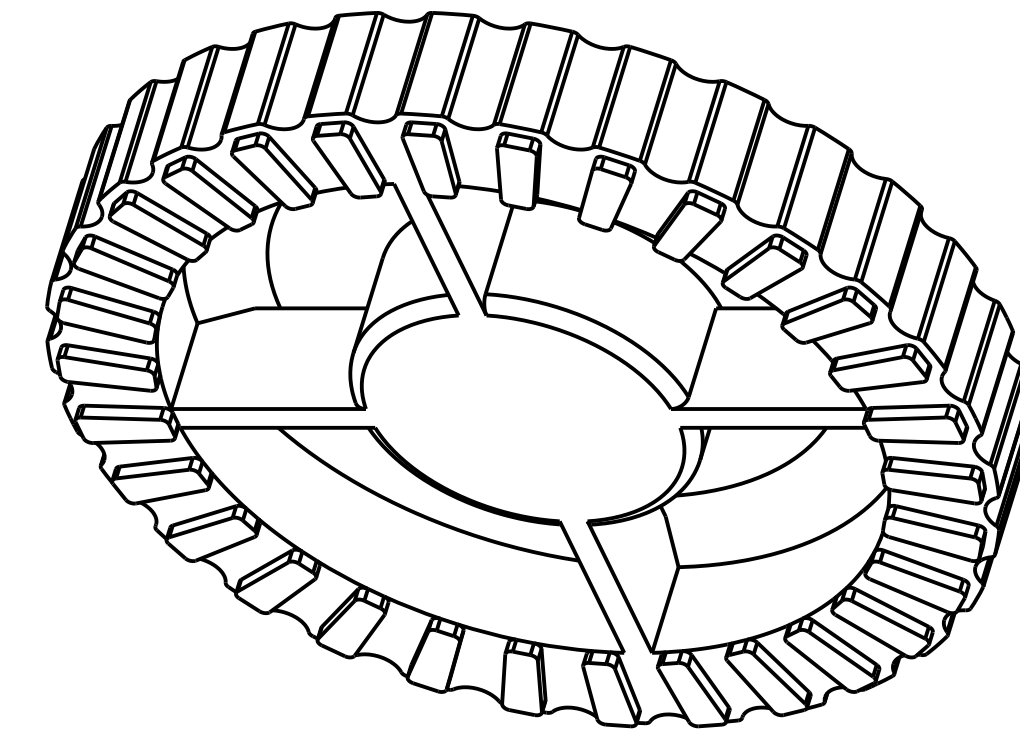

4x Leveling Pad

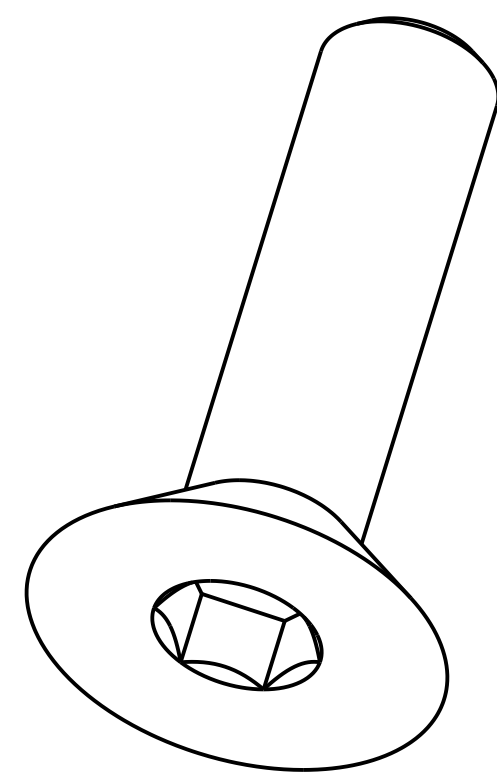

8x FB3

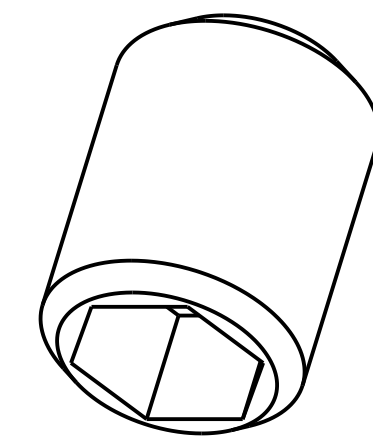

8x FB4

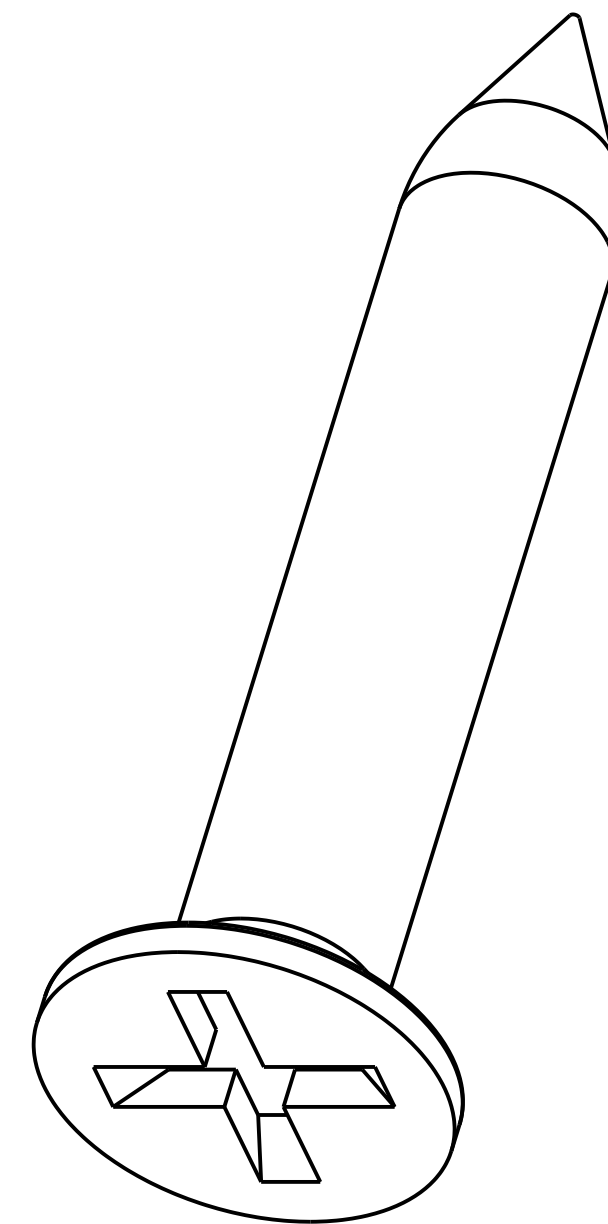

2x WS2

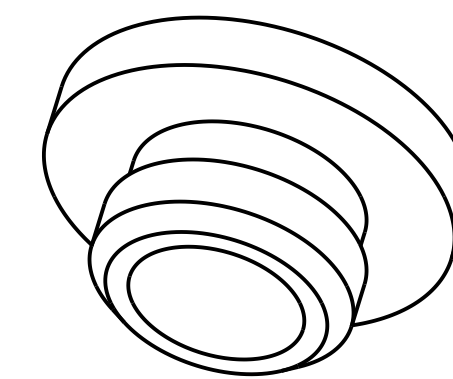

10x Rubber
Grommets

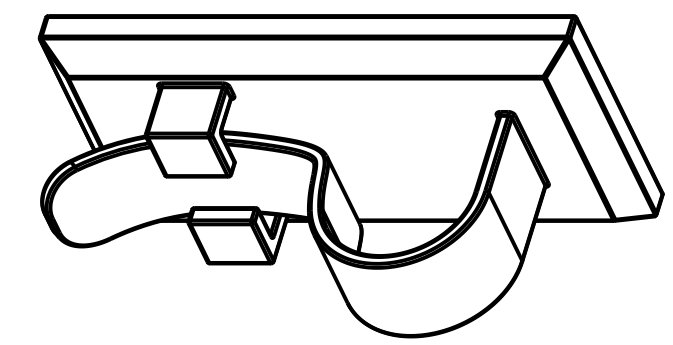

8x Tie Wraps

STEP 1

Do NOT dispose of packing material or start assembly before counting all pieces and inspecting the surface of your tabletop for damage. To avoid any damage to your table or your floor, assemble on top of a rug, carpet or blanket.

For ease and safety, we recommend two people for assembly.

Before assembly, consider where you want your desk to be located.

Ensure the location of the desk is free from obstacles. Uppeal desk is height adjustable, so it should be located a safe distance from window frames, furniture, radiators, and any other obstacles that could interfere with the movement of the desk.

Do NOT place any objects underneath the desk that are taller than 12", and consider any accessories mounted to your desk that would interfere with an object the area.

STEP 2

- Place Crossbar Assembly upside down as shown. Ensure the Crossbar Assemblies are oriented correctly with the mounting flanges pointing outward. Loosely install the Eight Set Screws (FB4) in the cross bar assemblies, do not tighten.
- Place the legs as shown below, so that the back of the Legs and the Crossbar Assembly ends are flush.
- Ensure all the screw holes are lined up to prevent thread damage, start the four M6x12 Machine screws (FB2) by rotating them for only a few turns through the Crossbar Assembly holes into the Leg as shown, do not tighten them all the way.

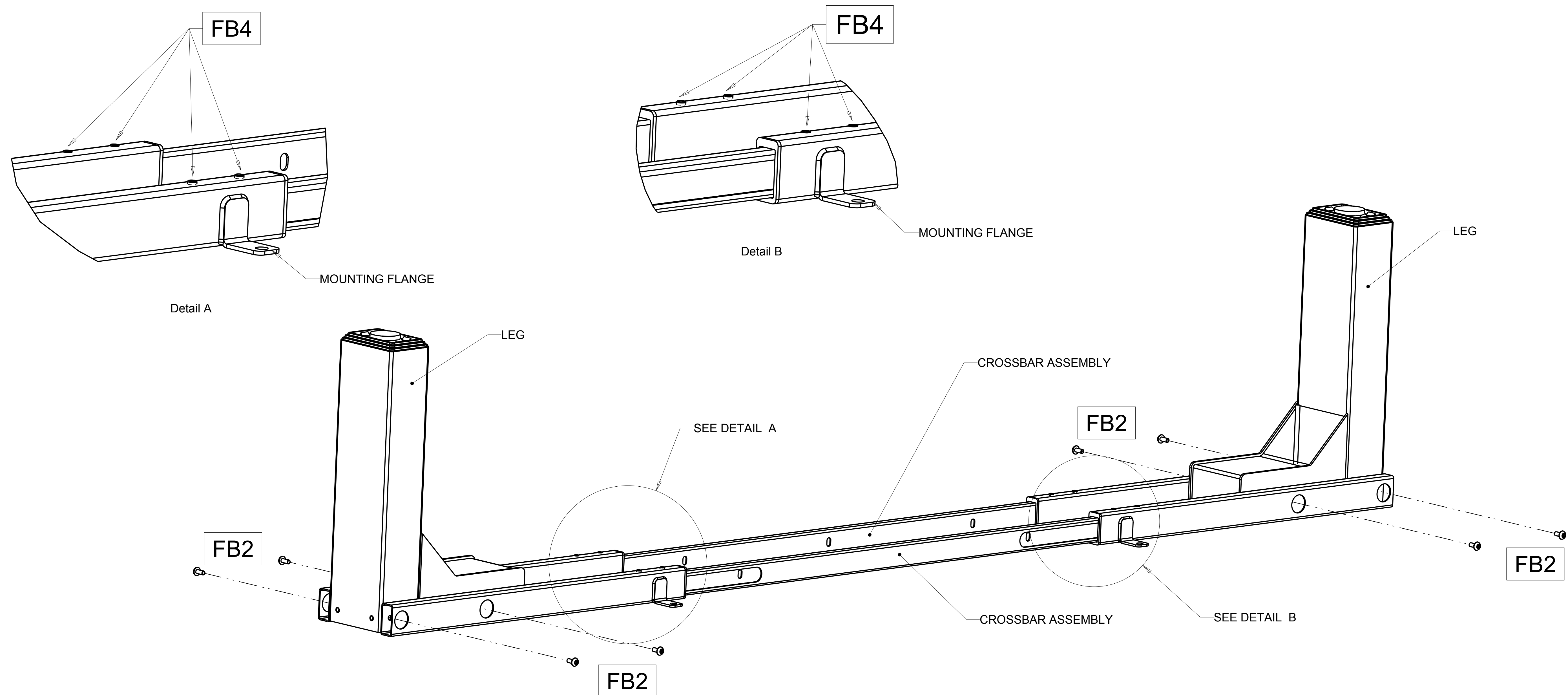

STEP 3

- Align holes in the Side Bracket with holes in the Leg, secure it loosely by using two M6x12 screws (FB2).
- Rotate each screw only a few turns to avoid damaging the threads.
- These screws will be tightened in a later step.
- Repeat this step for the 2nd Leg.
- If Rubber Grommets are not already installed in the desk frame, press in the 10 rubber grommets in the 10 holes that mount the frame to the tabletop. These grommets go in between the frame and the tabletop to protect the tabletop.

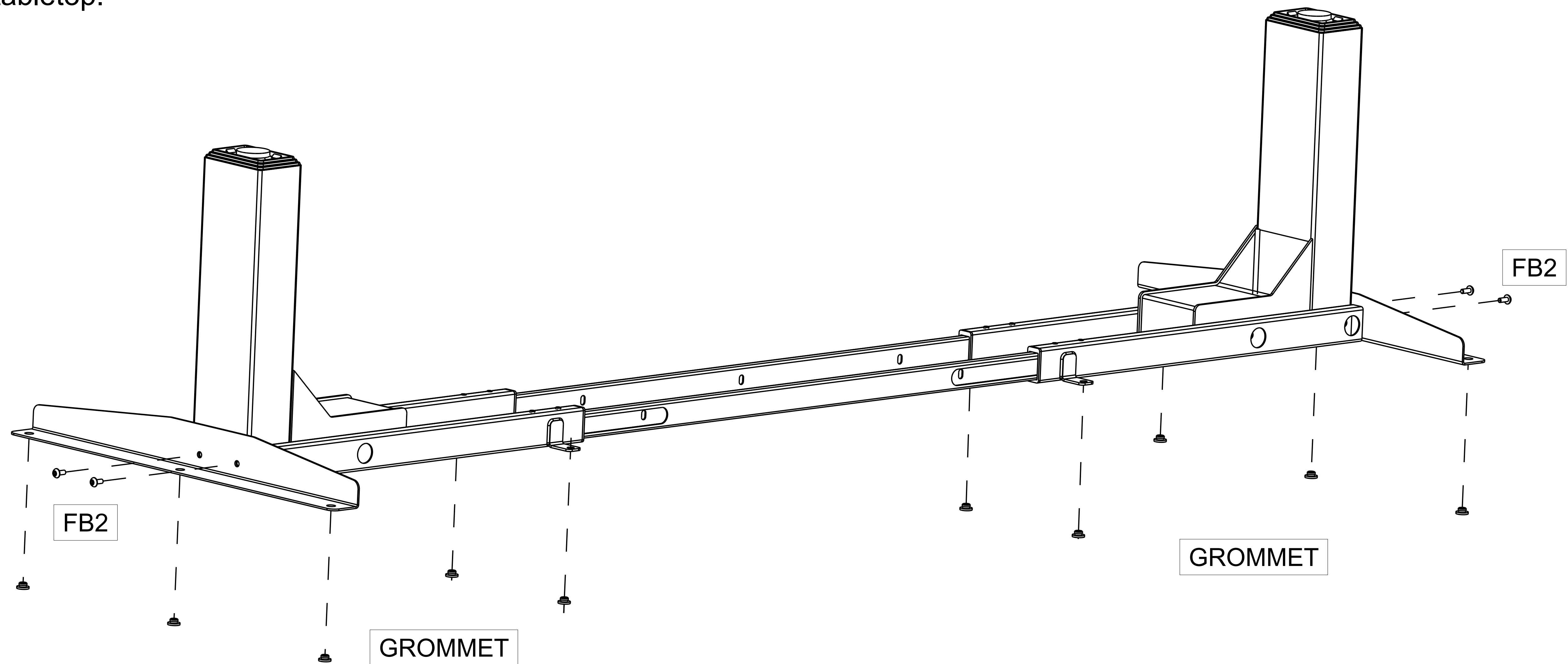

STEP 4

- Place your Tabletop upside down on a debris-free carpeted area or a blanket. If your Tabletop has pre-drilled holes or threaded inserts, they should be facing up.
- When placing your frame on your Tabletop, lift it up. DO NOT SLIDE IT. Sliding will cause damage to the tabletop and/or frame.
- When frame and tabletop are flush, hold down brackets against the tabletop and tighten four screws in End Brackets that were temporarily installed in the previous step.
- Then tighten the Machine Screws (FB2) installed in step 2, DO NOT Tighten the Set Screws (FB4).

For Desktops that have Pre-Drilled Holes or Threaded Screw Inserts:

- Move the frame assembly by lifting, and line it up with the pre-drilled holes or threaded inserts on the Tabletop.

For Desktops without Pre-Drilled Holes:

- Place the Frame where you would like. Measure from the Tabletop edges to ensure symmetry unless you have an asymmetrical Tabletop.
- Make a pencil mark at each hole location. Check that the frame assembly is in the right location prior to drilling by confirming that your marks are lined up.
- If you own a drill, you can make this a little easier by drilling pilot holes where you've made your pencil marks using a 1/8" diameter bit.

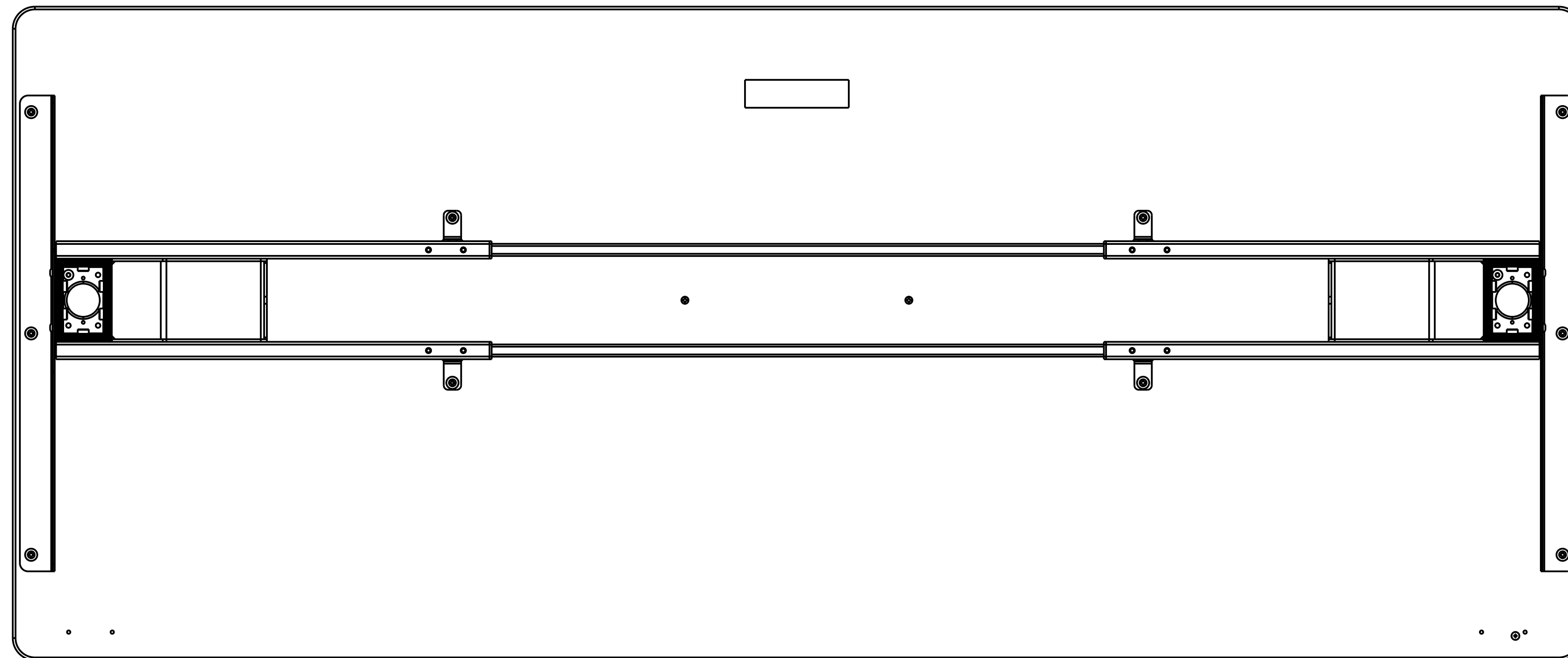

Note: DRILL NO DEEPER THAN 1/2". To ensure this, we recommend wrapping a piece of tape around your drill bit 1/2" from the tip. Stop drilling just before the tape touches the tabletop.

STEP 5

- Attach one side of the Frame to the Tabletop using five screws.
- Do not tighten all the way.
- For Tabletops without Pre-Drilled Holes or Threaded screw Inserts: Loosely fasten the Crossbar Assembly End to the Tabletop using screws (FB1).
- Do not tighten all the way.
- Once the first side is done, repeat the above steps for the other side.
- After all eight screws are started, go back and tighten them. Be careful to not over-tighten, to avoid stripping. Unless you have a Solid Wood Tabletop, then immediately refer to the note below.

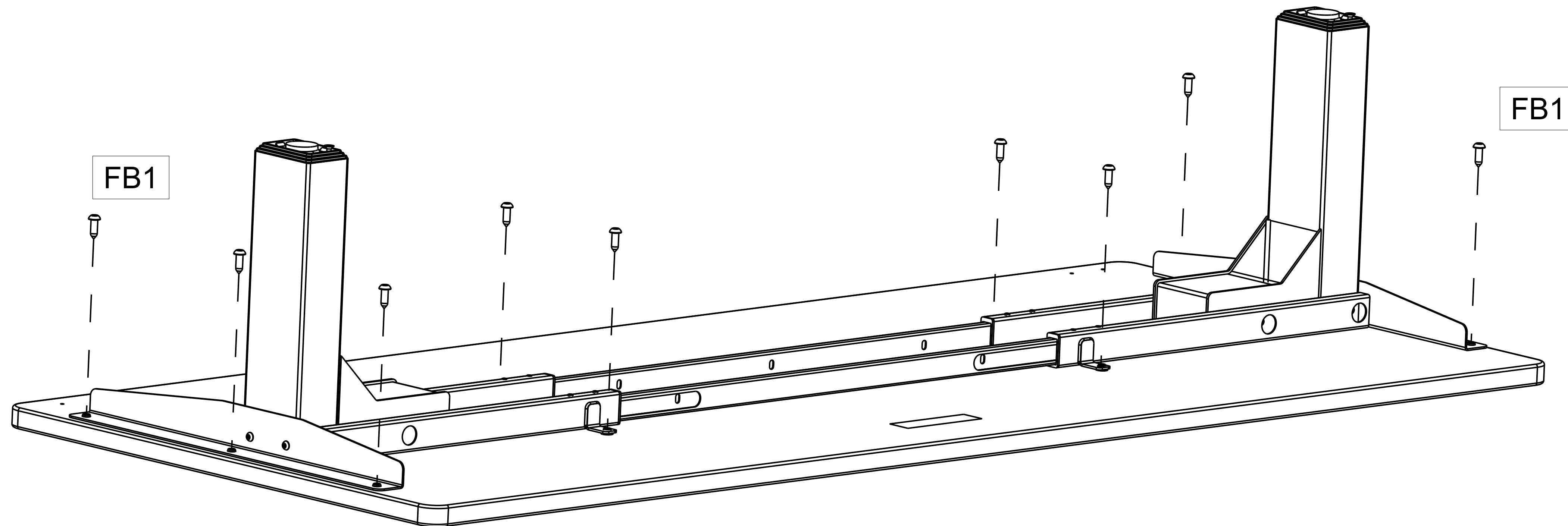

Important Note about Solid Wood Desktops:

- The bottom a Solid Wood tabletop can sometimes have uneven bottom surface creating gaps between the Frame and the tabletop.
- Screws that go in holes where there is no gap between the frame and tabletop can be screwed in completely.
- Screws that go in holes where there is a gap between the frame and the tabletop should be tightened only until the screw is snug. Over tightening where there is a gap can cause stress on the desktop which can cause cracks or warping over time.

STEP 6

- Orient the Crossbar Assembly inside rail so that the center indicator is approximately in the center of Crossbar Assembly.
- Tighten Set Screws (FB4) in the Crossbar Assembly

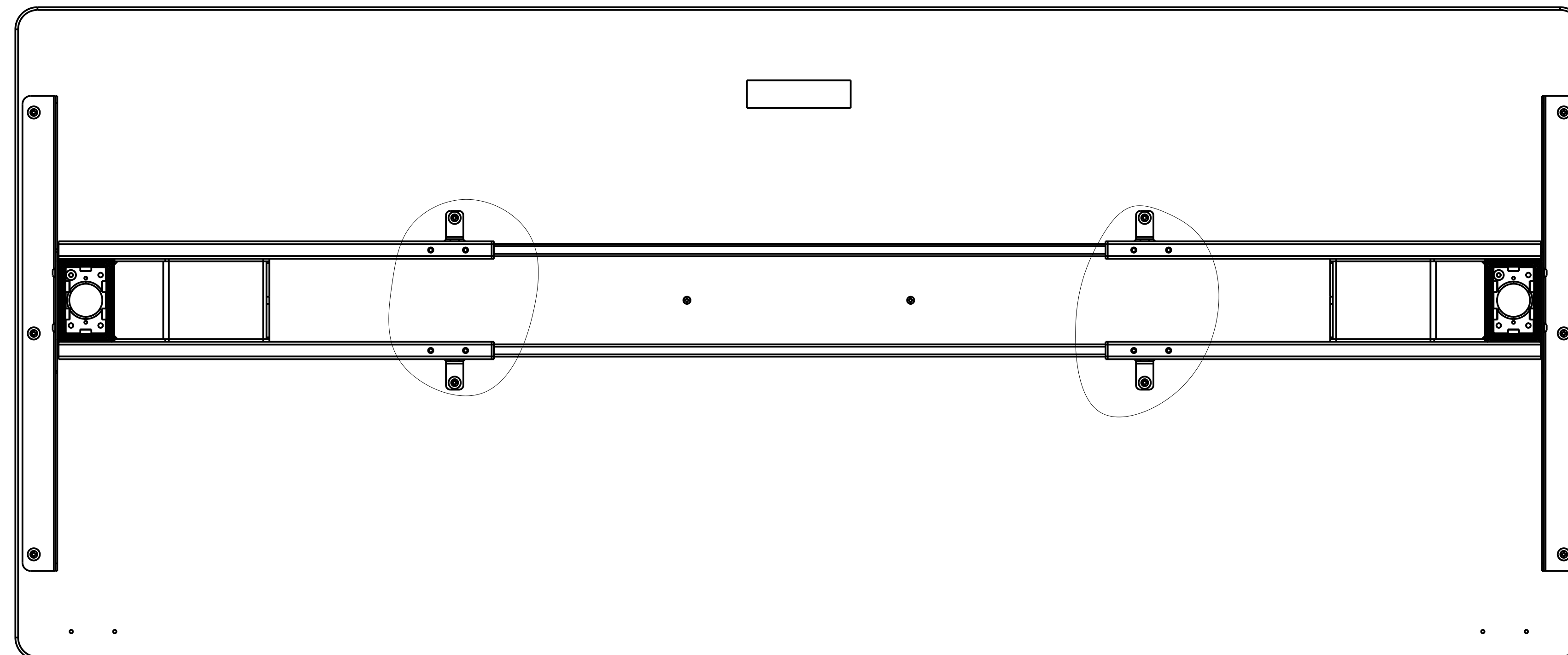
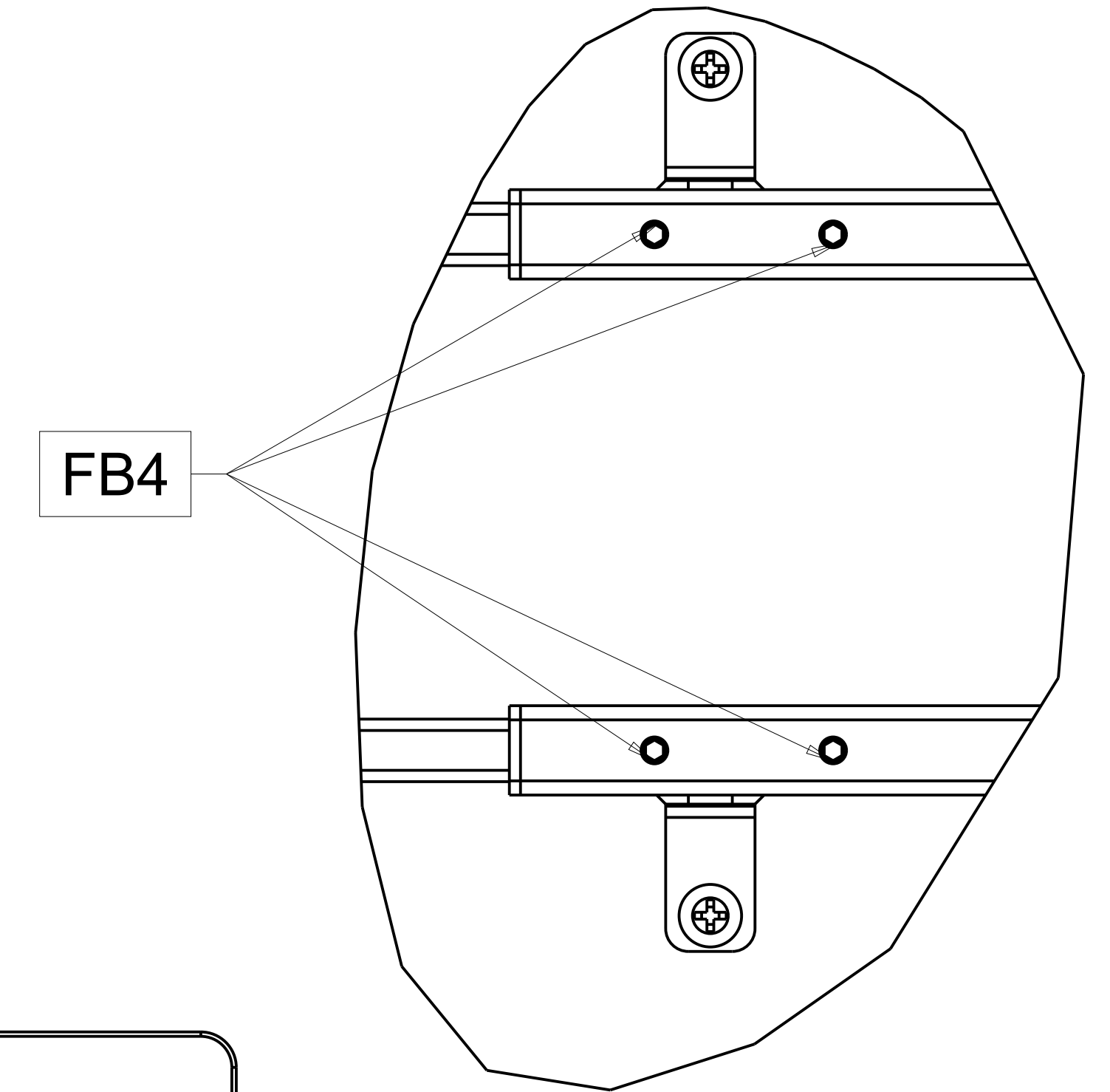
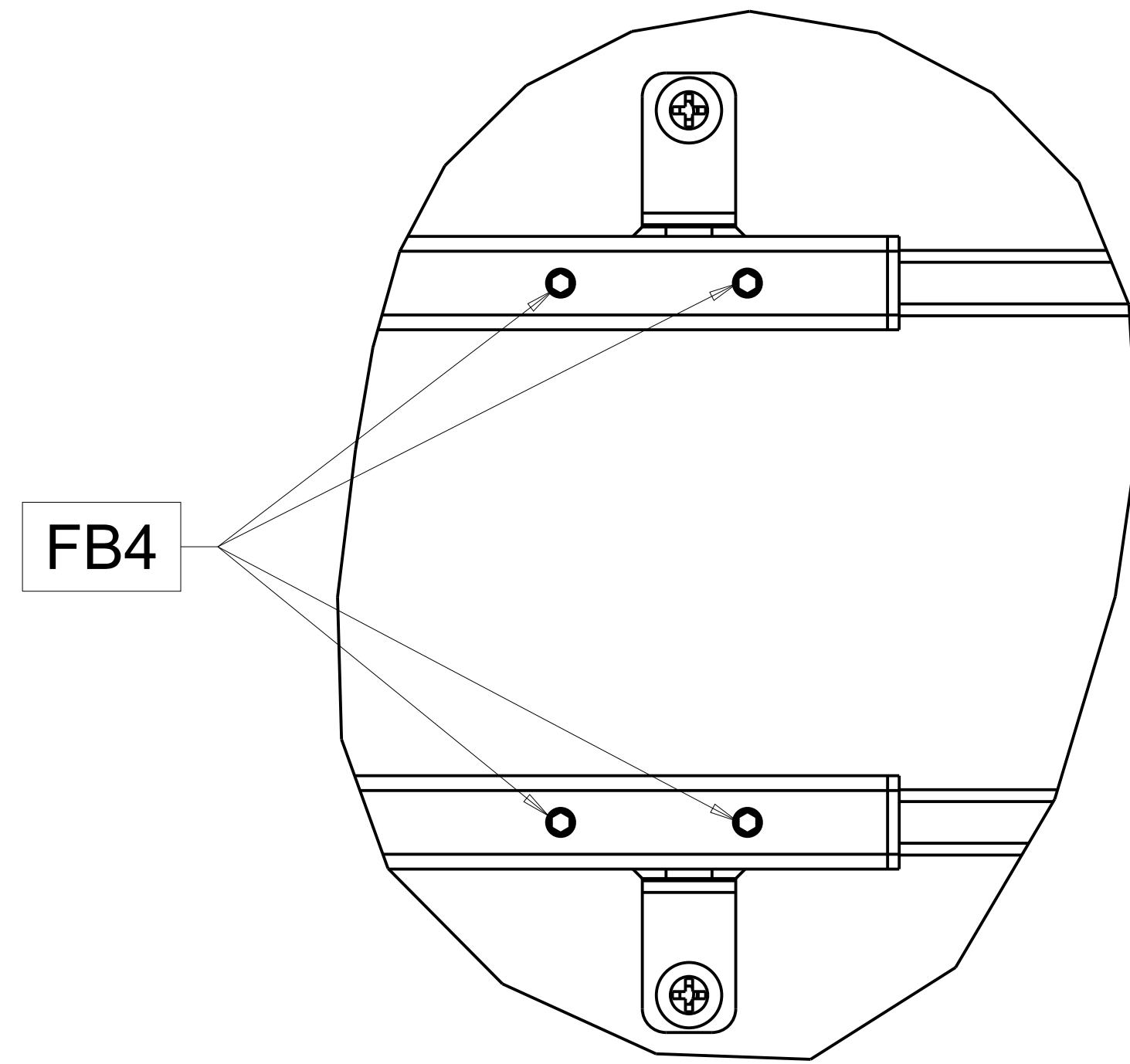

STEP 7

- Choose which side of the Tabletop you'd like your Keypad to be on. Bear in mind that you're installing your desk upside down, so the final location of the Keypad will be opposite of what you're seeing during assembly.

For Desktops with Pre-Drilled Holes:

- There are two sets of holes to accommodate the Keypad. Use two Wood screws (WS1) to attach it to the Tabletop.

For Desktops without Pre-Drilled Holes:

- The Keypad can be placed anywhere along the front edge of the Tabletop. Typically you will want it to the side where it won't interfere with your legs, chair, or any accessories. Once chosen, hold the Keypad in the desired location and make a pencil mark at each hole location.
- If you own a drill, you can make this a little easier by drilling pilot holes where you've made your pencil marks using a 1/16" diameter bit. Then fasten the keypad with the two Wood screws (WS1).

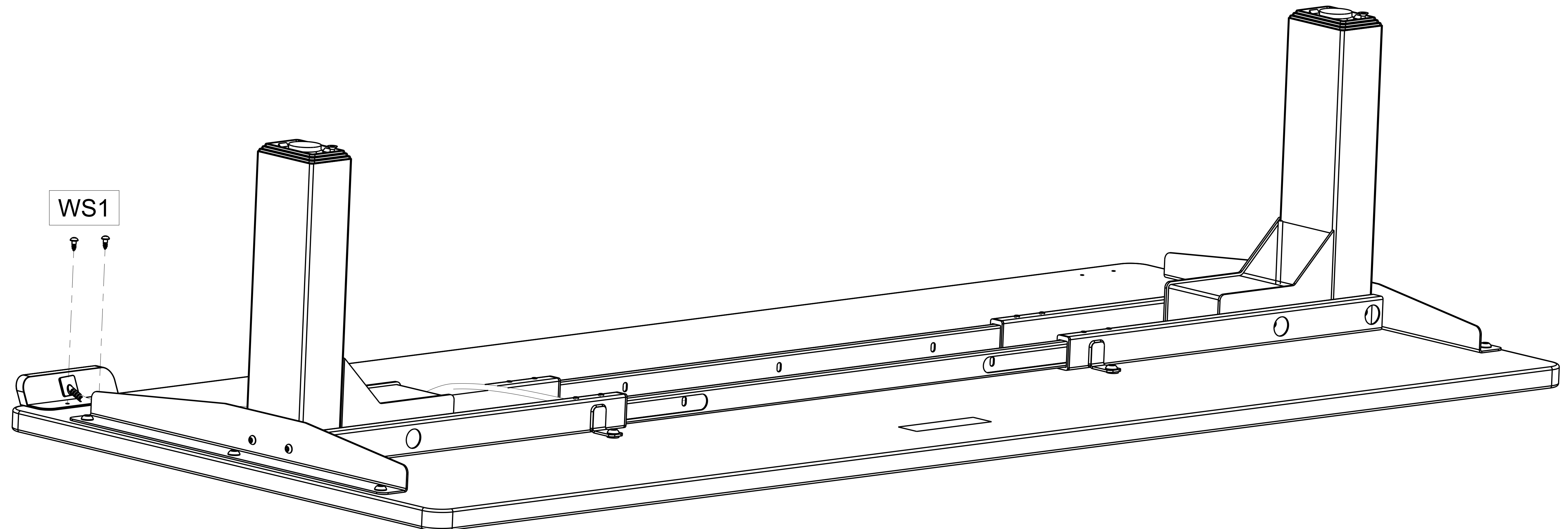

STEP 8

- **Make sure the long end of the Feet are facing towards the front of the desk,** in the same direction as the Side brackets. The Feet are slightly longer on one side of the mounting area than the other.
- Place the Feet onto the Leg as shown. Loosely start four M6x16 Machine screws (FB3) by hand.
- Once all four screws have been started, tighten all the way using the 4mm Allen wrench. Repeat this step for the 2nd foot.
- Install Four Leveling pads into threaded holes in Feet.

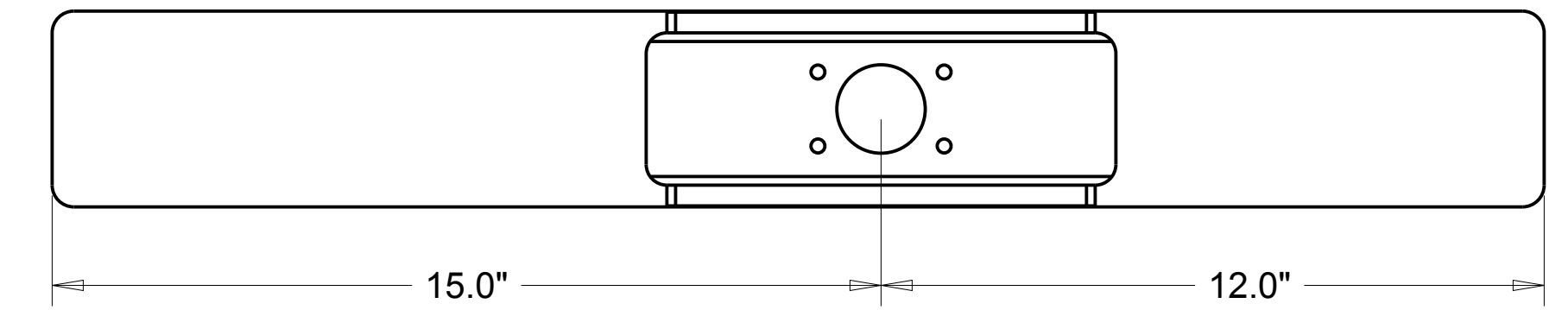

Feet are longer on one side

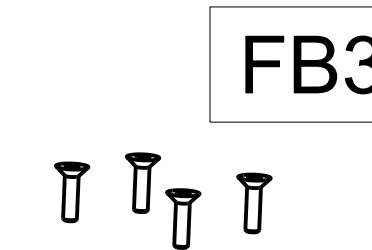

FB3

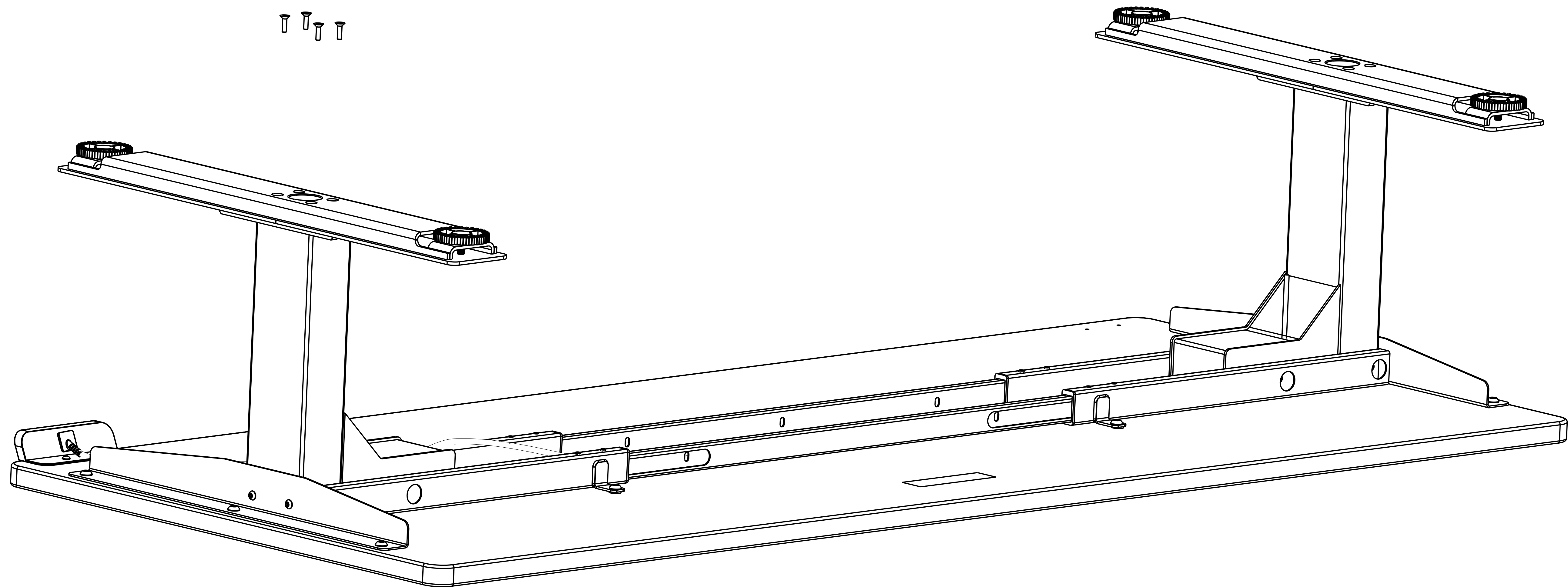

STEP 9

- Position the Control box with the Power Cable end pointing away from the Leg on the side of your desk where the Keypad is attached.
- Install wood screws (WS2) before installing the cables.
- Plug in the Power Cable, Keypad Cable, and 2 Motor Cables into the Control Box.
- Plug the each Motor Cable into each Leg.
- Route cables using tie wraps, see diagram below.

For Tabletops with Pre-Drilled Holes:

- There are two sets of holes to accommodate the Control Box. Line up your Control Box with the pre-drilled holes, and attach it to the Tabletop with two Wood Screws (WS2).

For Tabletops without Pre-Drilled Holes:

- The Control Box should be near but no on the rear edge of the Tabletop similar to what is shown below. Ensure it won't interfere with your legs, chair, or any accessories. Once chosen, hold the Control Box in the desired location and make a pencil mark at each hole location.

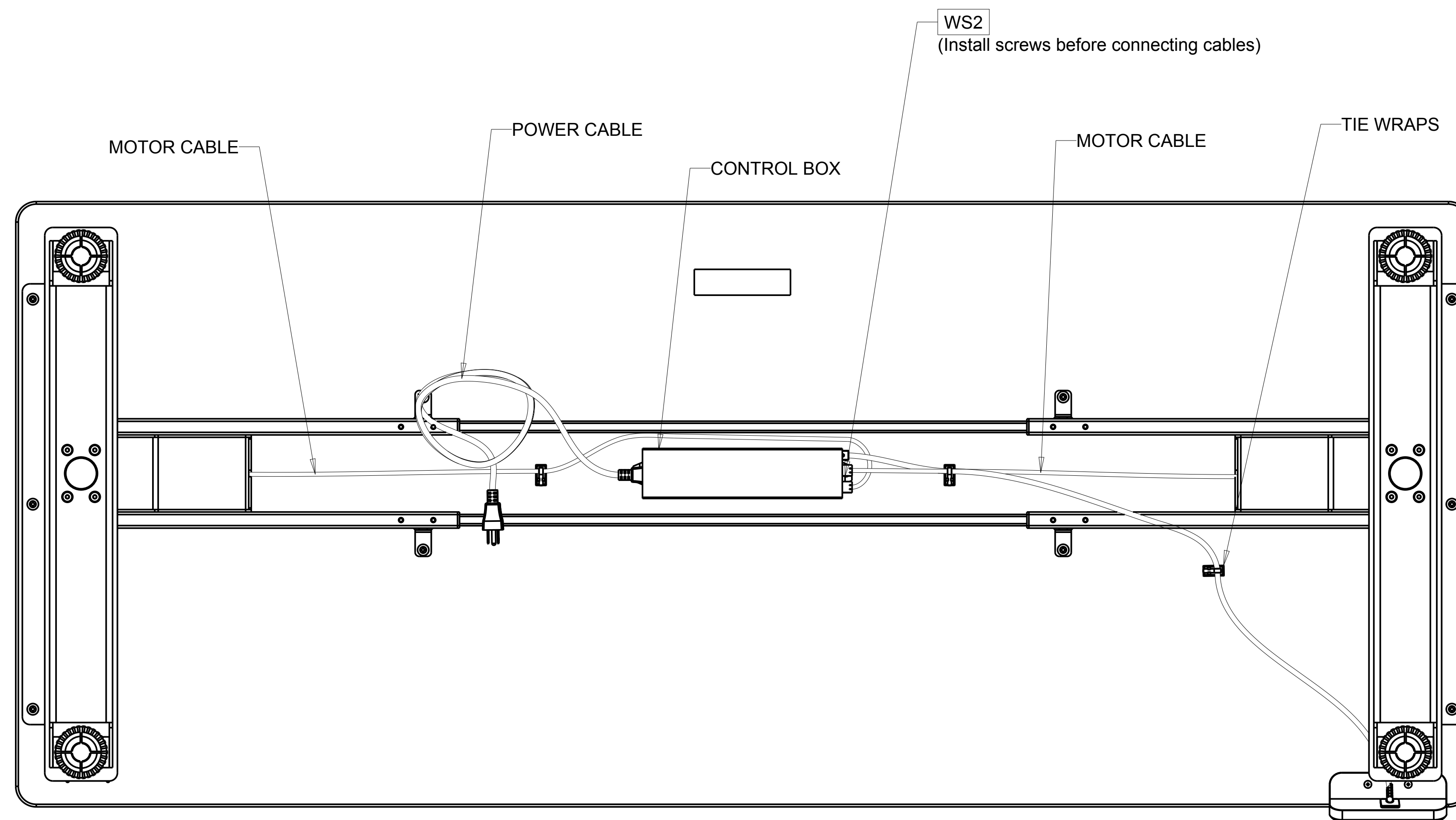

NOTE: Control Box must be securely fastened to your frame in order for your desk to work properly.

STEP 10

- With the assistance of your helper positioned on opposite ends of the desk, grab the tabletop AND Side bracket with one hand and a Leg in the other.
- Be aware and be careful of the cables, any attached components or accessories especially an accessory that might move on a track like a Keyboard tray or CPU holder.
- Support the desk frame and the Tabletop equally and tilt it gently rotating it 90 degrees back, so the Keypad is facing up.
- Readjust your grip at the Tabletop and Side bracket with one hand and keep the other hand on the Leg. Lift and rotate 90 more degrees until your Desk is right-sideup.
- Adjust the leveling studs or Casters as needed to make the desk level.

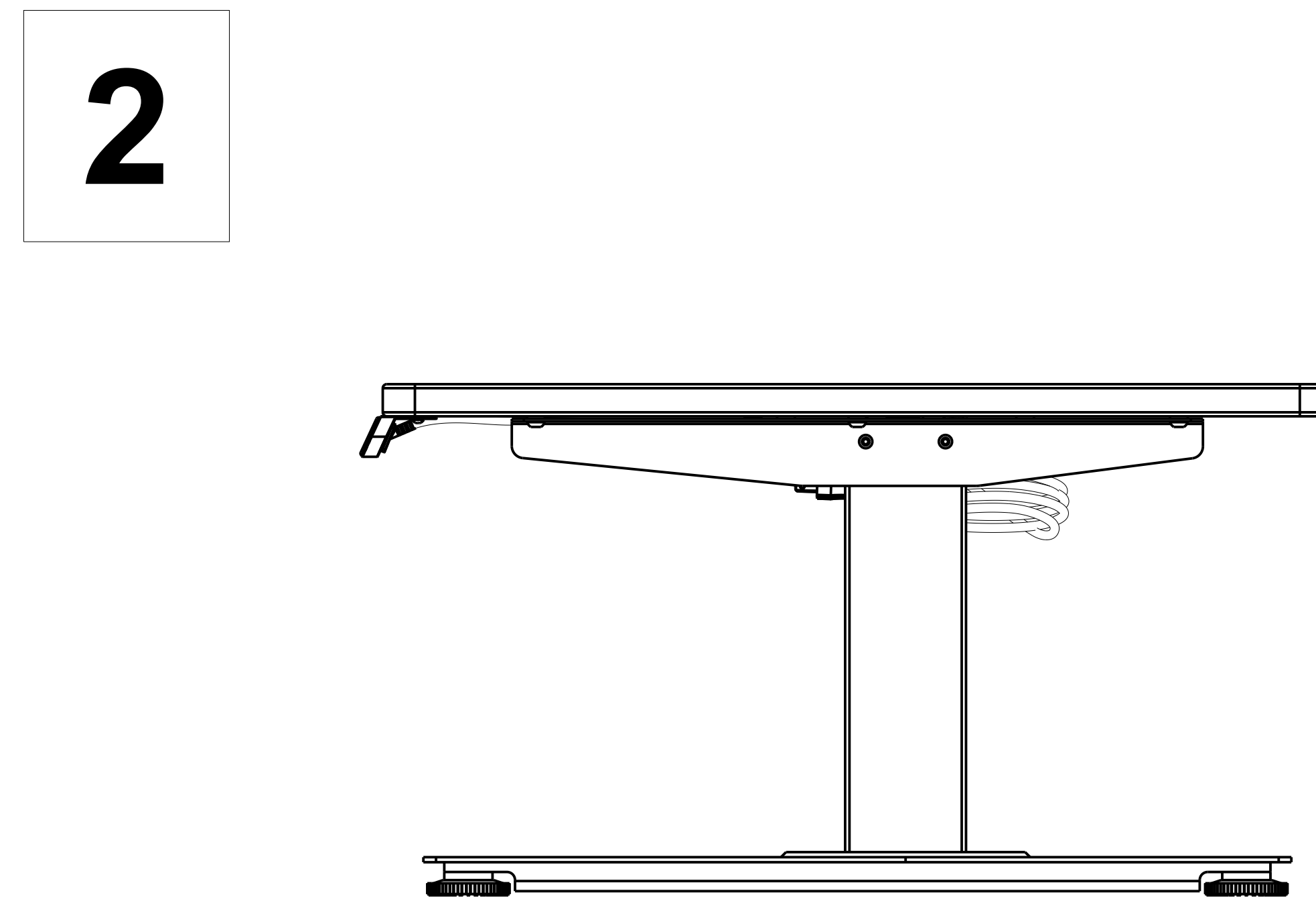
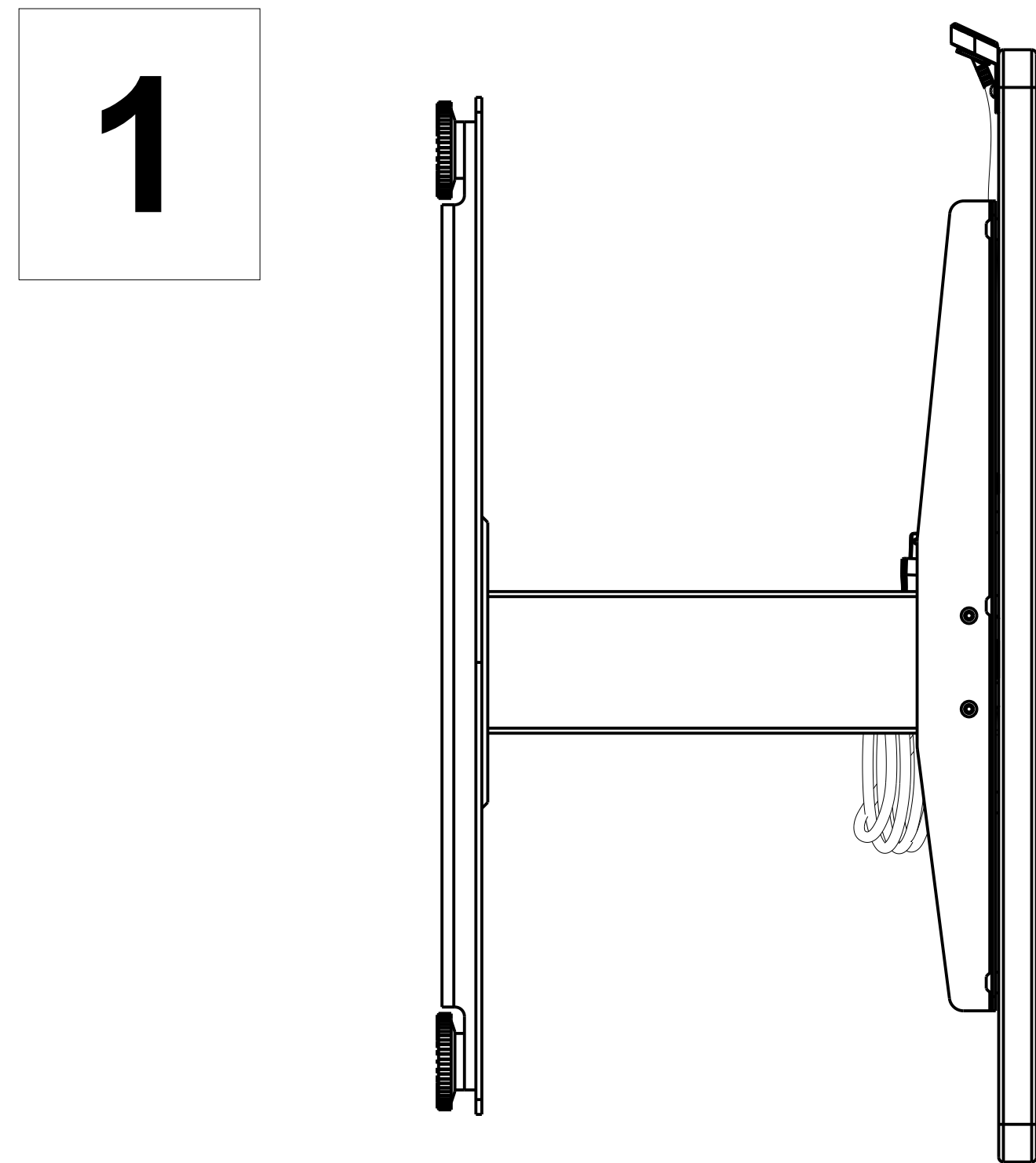

STEP 11

- Check your desk's surroundings to make sure there will be no obstacles in the desk's path and that all cords are long enough to accommodate the motion of your desk.
- Plug your desk into a 120V outlet.
- You should be able to operate the desk! Try moving it all the way up and all the way down before setting up your workspace.

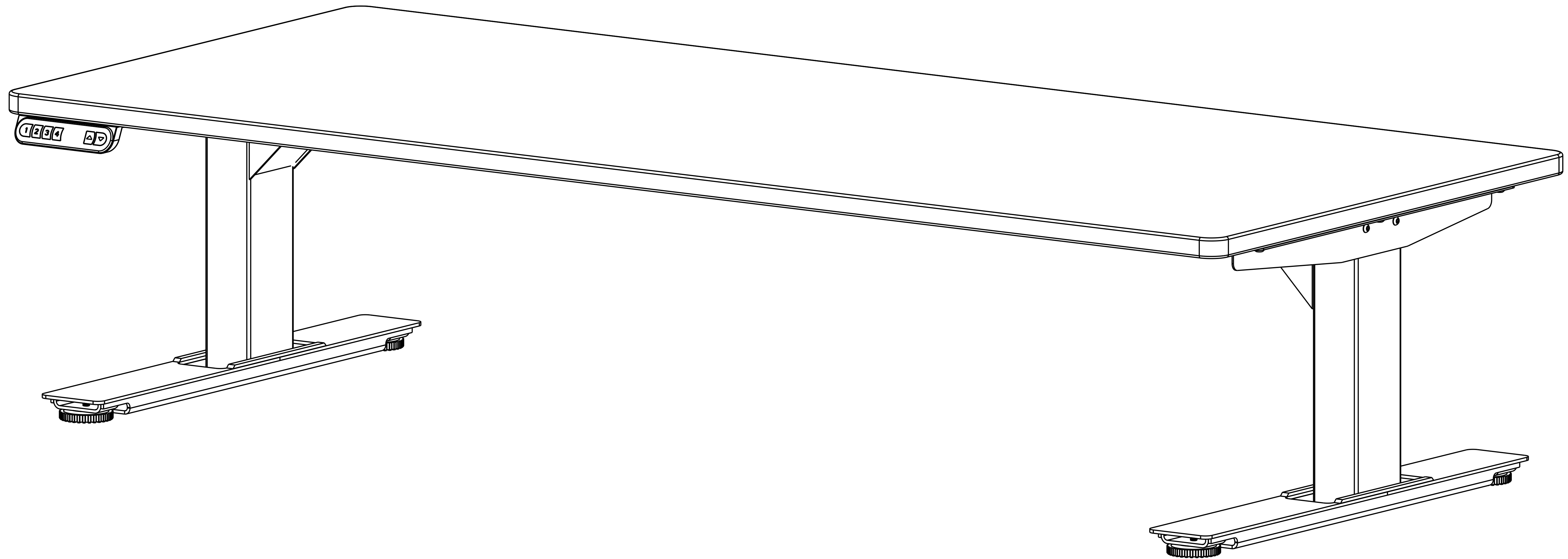

PROGRAMMING MEMORY KEYPAD



MEMORY SETTINGS:

Save up to four commonly used desk heights and recall them quickly.

1. Use the UP or DOWN button to move the desk to the desired height.
2. Determine which Memory Key you would like to store this height to and press that Memory Key 4 times quickly one after another. The controller should play a sound, now the position is stored in the selected memory key.

TROUBLESHOOTING

NO RESPONSE

If your desk does not respond when you try to raise it or lower it, check to make sure all the cables are secure (Legs to cables, cables to Control box). If the problem persists, perform the reset procedure below.

RESET PROCEDURE

1. Unplug the power cord and hold the DOWN button on the Keypad for 30 seconds.
2. Plug the power cord back in.
3. Press the UP Button four times quickly, then press the DOWN button four times quickly.
4. The Keypad should display "- - -". Once it does, hold the DOWN button until the desk reaches the reference height and the Keypad displays a number. The desk should lower very slowly in this mode.
5. After completing the reset, you should be able to operate the desk.

WOBBLING

Check the 4 foot levelers are all touching the floor.

Check that all bolts are tight.

Move desk off of soft surfaces under desk feet, like rugs, carpet, etc..

Information

250 lbs Max Weight

Questions? Email Us!
info@uppealdesign.com