

Uppeal - Adjustable Height Desk

SKU: FONLYB

Specifications

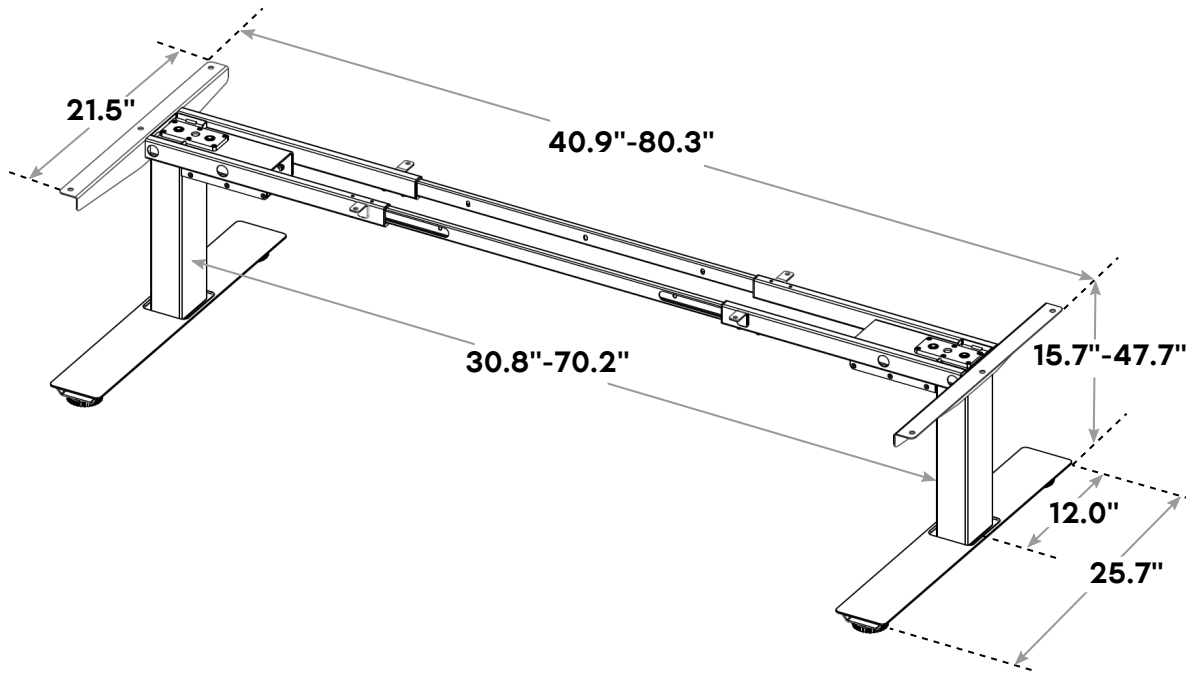

Height Range	15.71"-47.71"
Travel Speed	1.8"/second
Noise Level	50 dB
Lifting Capacity	250 lbs
Current	4A Max
Voltage Input	100-120Vac, 50/60 Hz, 400W max
Warranty	10 year



Bifma G1-2013
Designed to Height Standard



Dual Motor



Bifma X5.5-2021
Designed to Durability Standard



Anti-Collision Detection



4 Stage Legs 25% faster
than 3 Stage Legs



Quiet Adjustment



2 Color Options



For technical questions and support email info@uppealdesign.com or visit us at uppealdesign.com



uppealdesign.com



Uppeal

Desk Specifications Rev A