

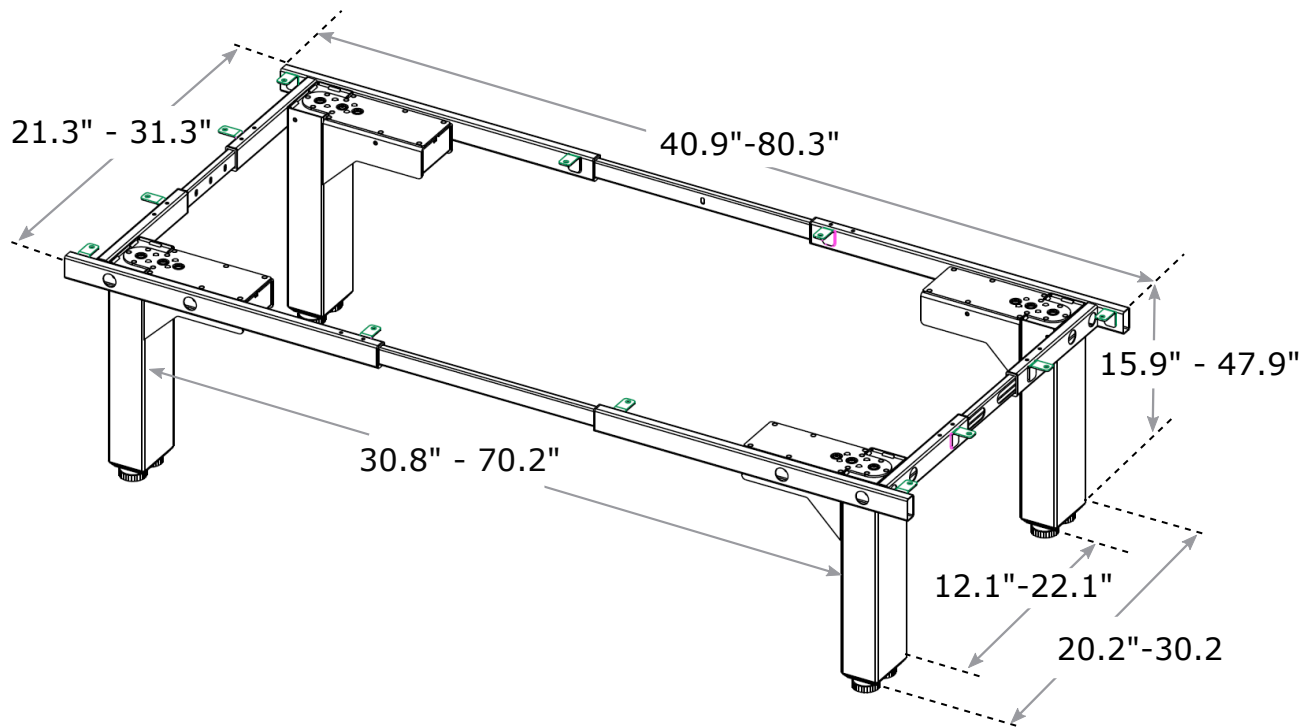

Uppeal - Four Leg Adjustable Height Desk

Specifications

SKU: 4CMW





Height Range	15.91"-47.91"
Travel Speed	1.8"/second
Noise Level	50 dB
Lifting Capacity	450 lbs
Current	4A Max
Voltage Input	100-120Vac, 50/60 Hz, 400W max
Warranty	10 year

 Bifma G1-2013
Designed to Height Standard

 Quad Motor

 Bifma X5.5-2021
Designed to Durability Standard

 Anti-Collision Detection

 4 Stage Legs 25% faster
than 3 Stage Legs

 Quiet Adjustment

 2 Color Options

 For technical questions and support email info@uppealdesign.com or visit us at uppealdesign.com