

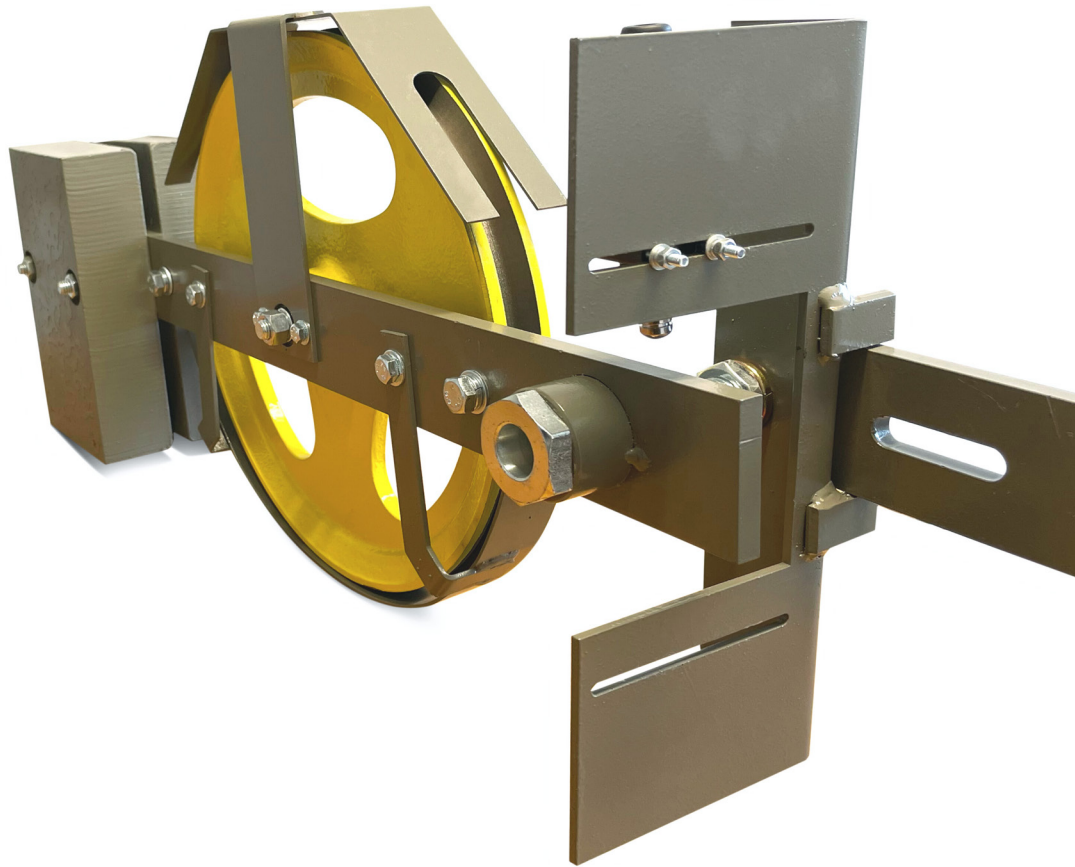

# TENSION DEVICE



## CONTENTS

ABOUT DELCO .....	3
HOW TO ORDER .....	3
SPECIFICATION .....	4
General Specification .....	4
Slack Rope Switch .....	4
WORKING PRINCIPLE .....	5
Features .....	5
INSTALLATION .....	8
Safety Requirements .....	8
Equipment Verification .....	8
RIGHT Hand Configuration .....	9
LEFT Hand Configuration .....	13
Mounting Location .....	15
Lubrication .....	15

## ABOUT DELCO

### In Stock, Non-Proprietary, Proven & Competitive

Delco Elevator Products Ltd. has always been a family owned and operated business and is proud to have been helping our customers with elevator components for over 45 years.

With a head office and warehouse in Vancouver, BC, Canada, and a warehouse in Seattle, WA, USA, Delco is strategically located to source, stock and ship elevator products to customers in Canada, the Caribbean and the US.

From Haider Drive machines to popular components, including roller guides, shackles, oil buffers, governors and door edges to a range of elevator parts, the company's comprehensive product selection is one of the reasons that customers have been returning to Delco for decades.

Another reason is that we are very good at ensuring that the right items arrive at the right time to elevator contractors across North America.



Delco's dedicated, experienced and enthusiastic team works diligently to provide exceptional service in the following key areas:

- **In Stock:** We keep our components stocked to make sure that customers receive what they need, when they need it.
- **Non-Proprietary:** Delco's products are universal – perfect for modernizations.
- **Proven Products:** Delco manufactures and distributes products that are tried, tested and proven in the field.
- **Compliant:** Delco products and equipment meet all elevator industry compliance and certification standards.
- **Value for Money:** In a highly competitive marketplace, Delco provides the best quality elevator equipment at the lowest possible prices.
- **Personal, Knowledgeable Staff and Service:** Always on hand to assist you with your unique requirements!

## HOW TO ORDER

**Delco services elevator contractors and OEMs in Canada, the Caribbean and the US, including Puerto Rico and Hawaii.**

We'd love to hear from you and give you a quote on your next project. **Call, email or visit us today!**

OFFICE & WAREHOUSE CANADA  
#205-3765 1st Avenue  
Burnaby, BC V5C 3V8

WAREHOUSE USA  
2302 West Valley Highway North, Suite 300, Auburn,  
WA 98001

**Phone: 1.604.904.3727 - CAN/USA**  
**Toll Free: 1.866.900.3727**  
**Email: [info@delcoelevator.com](mailto:info@delcoelevator.com)**  
**[www.delcoelevator.com](http://www.delcoelevator.com)**

We look forward to welcoming you to our family of customers and friends.

## SPECIFICATION

The Delco Tension Device is a non-proprietary device designed to work with the Delco governors.



### General Specification

Car rated speed range	0.50-2.54 m/s	100-500 FPM
Sheave Pitch Diameter	305 mm	12 inch
Rope Diameter	9.5 mm or 10 mm	3/8 inch or 10 mm
Rope Type	Traction Steel 8 X 19	
Tension force	450 N	101 Lbf
Slack rope Switch	YES	
Installation	Configurable for Left and Right	
Protective cover	YES	
Shipping weight	38.5 kg	85 Lbs
Delco SKU	C-12-4000	

### Slack Rope Switch Specification

Switch part number	LX26-UKS
Manufacture	Shanghai Huasheng Electric Co. Ltd.
Contact type	1NO – normal open spring loaded
Frequency	50/60 Hz
Rating	24 V -1 A ; 220 V- 4 A;380 V – 2.5 A
Ambient Temperature	+6 °C to +45 °C
IP Rating	IP67

This tension device should only be used in indoor applications.

## WORKING PRINCIPLE

- The Delco Tension Device is a swing arm type attached to the car rail. A cast iron weight is attached at the end of an articulated arm. The arm has also attached a sheave that is designed to work with the same type of wire ropes used on the Delco overspeed governors.
- The arrangement provides a constant tension on the governor rope and in a case of a governor mechanical tripping, the rope tension will set the car safeties.

## Features

- The symmetrical design of tension device allows the unit to be configured for use on left hand or right hand applications.
- Also the sheave carrier arm can be installed on the threaded sheave in two arrangements (see figure 2&3). This will allow the positioning of the governor rope center line in two dimensional ranges relative to the base surface of the rails:
- The guide bracket is designed with multiple sets of slotted holes for adjustability (see figure 1) to fit different rail sizes, and the distance between the governor rope and the center line of the guide rails:

1. 23-48 mm (0.90-1.89" )
2. 97-122 mm (3.81-4.80")

1. 240 <sup>+20/-10</sup> mm (9.44 <sup>+0.79/-0.39</sup> ")
2. 320 <sup>+20/+20</sup> mm (12.59 <sup>+0.79/-0.79</sup> ")

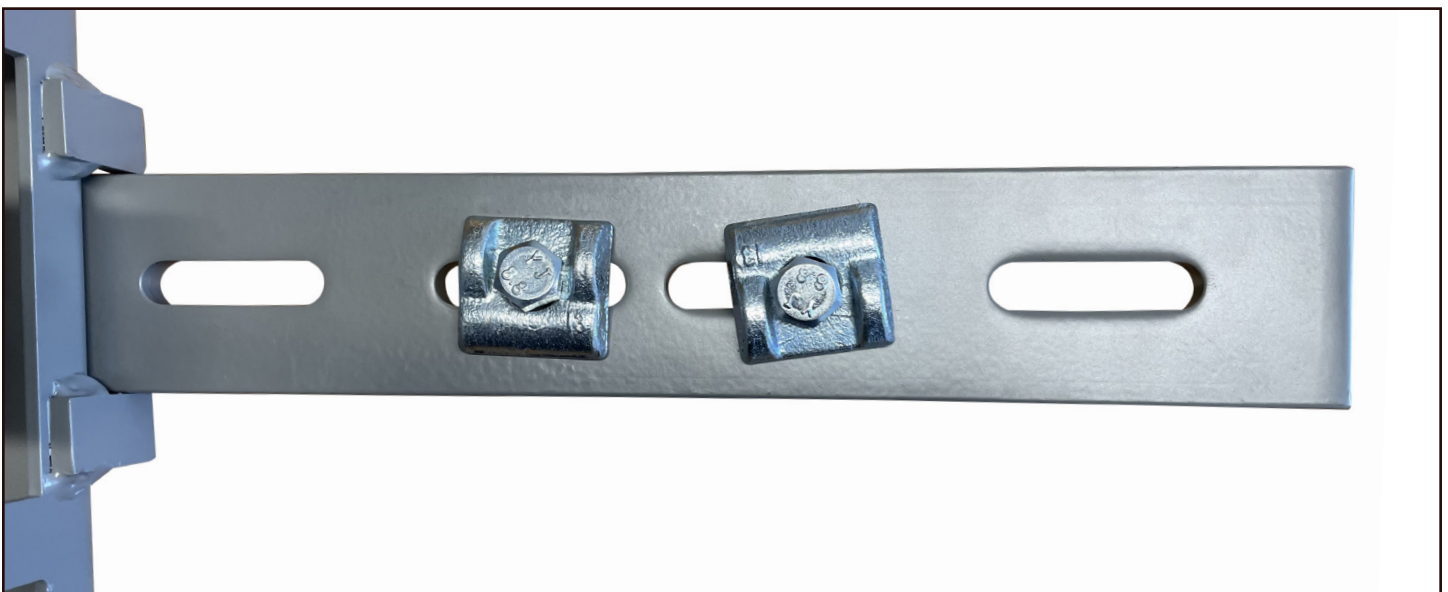

Figure 1



Figure 2

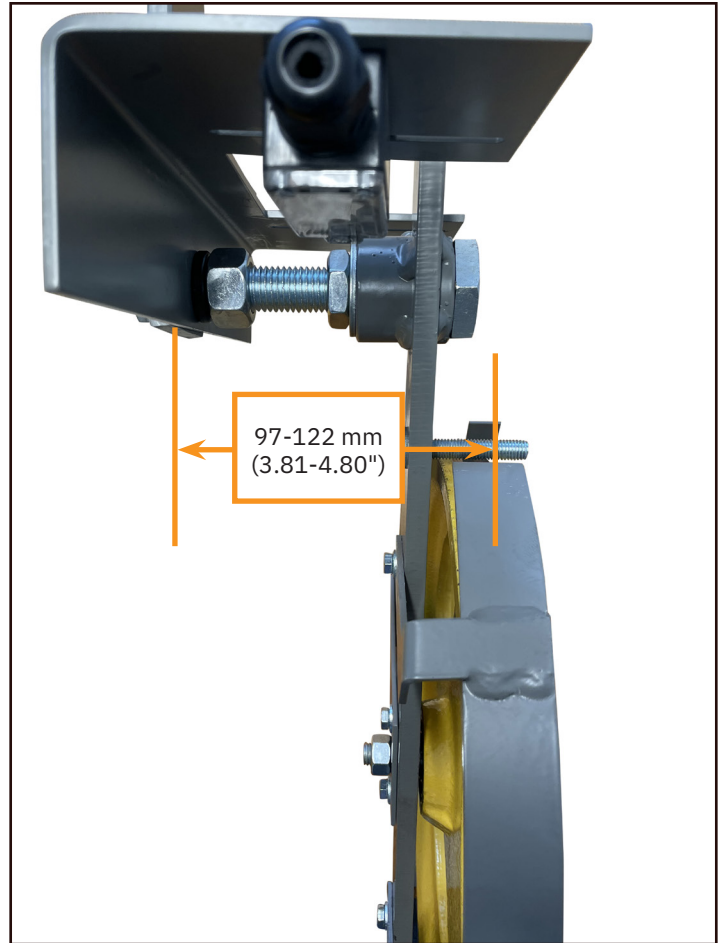

Figure 3

The tension device is equipped with a slack rope switch that will provide an electrical control signal in the event that the tension weight has moved beyond a set swing angle (25 ° down from horizontal) due to slack or broken governor rope.

The mounting holes for the slack rope switch are provided on both sides of the angular contact bracket, and are slotted to allow a wide adjustability ranges for the position of the switch. (see figure 4)

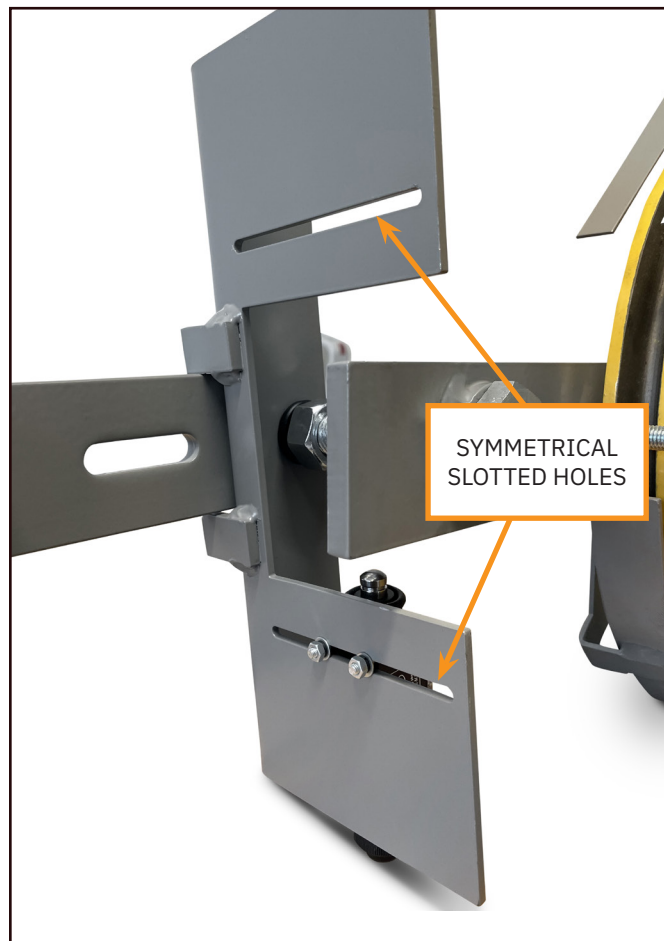

Figure 4

Part of the standard kit is a set of wedge shackles and a linkage set with a pin to connect the governor rope to the car safeties (see figure 5 & 6).

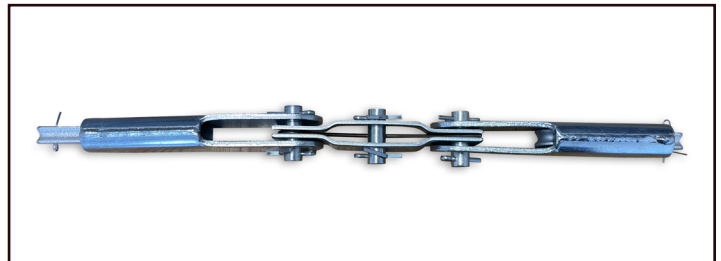

Figure 5



Figure 6

## INSTALLATION

### Safety Requirements

- Installation of the Tension Device should be done by qualified and certified personnel.
- Adequate personal protective equipment must be worn for the installation.
- Tools and equipment used for the installation must be inspected and in a good condition for the work.
- National and local, governing elevator safety requirements must be followed.
- Read and understand the product installation instructions provided before proceeding.

### Equipment Verification

- Before installation in the field, verify that all the Tension Device components are present and there is no visible damage to any parts.
- After the device is unpacked, it has to be configured for the specific application. Typically, the device is packaged as a right hand unit with the guide bracket behind the sheave for transportation (see *figure 1*) and the threaded sleeve arrangement is set for the 23-48mm (0.90-1.89") range.

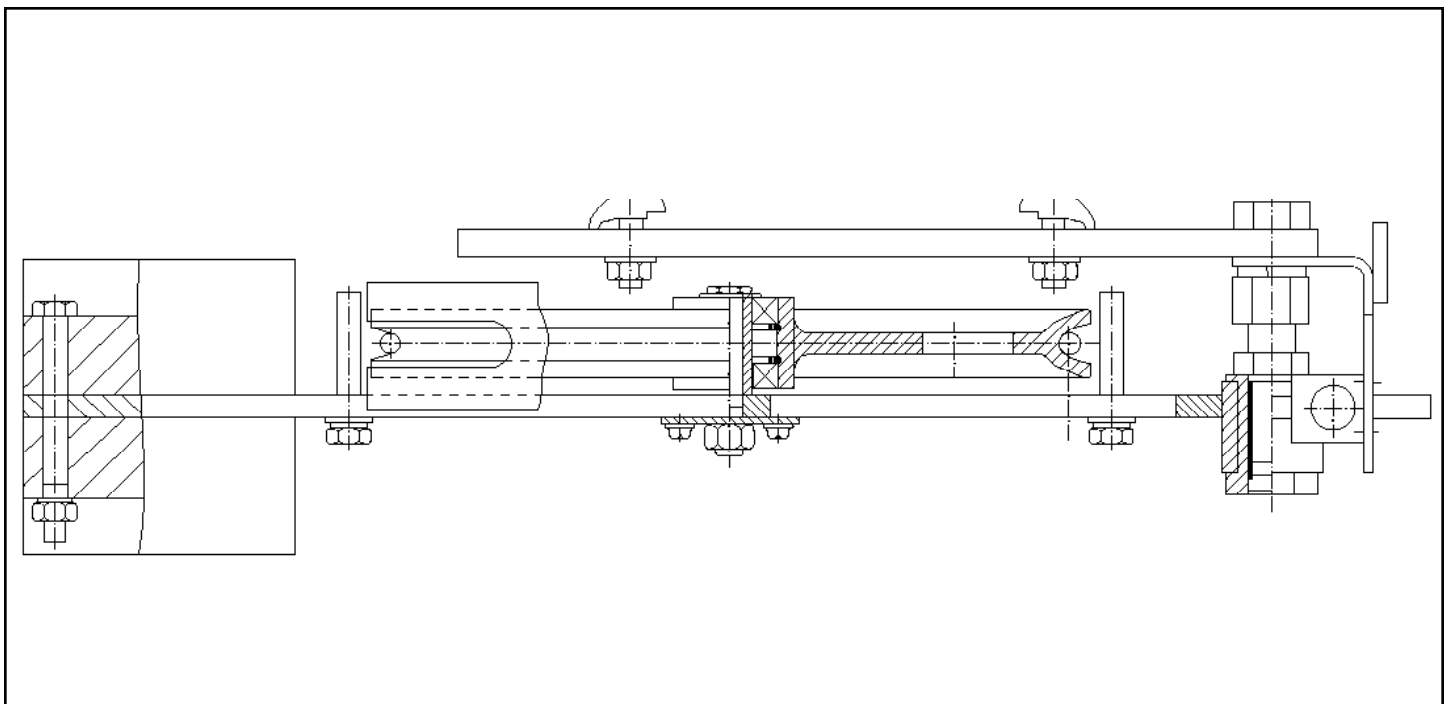

Figure 1



## RIGHT Hand Configuration

### 23-48mm (0.90-1.89")

Follow these steps to prepare the unit:

1. Loosen the Nut 1 and back up the nut ~ 16 mm (5/8") to allow for the rotation of the guide bracket with 180 ° from initial position (see figure 2).
2. Tighten the Nut 1 until the split Washer 1 is fully collapsed.
3. To adjust the position of the governor rope center line relative to the base surface of the rail within the 23-48 mm (0.90-1.89") range, loosen Nut 2 (see figure 3). Grease lightly the outside surface of the threaded sleeve.
4. Rotate the threaded sleeve to position the sheave to the required distance.
5. Lock the position and the rotation of the threaded sleeve by tightening the Nut 2.
6. In order for the slack rope switch to work correctly, it is important that the switch is aligned with the swing arm, so that the switch head is centered on the swing arm (see figure 6). The switch head allowable travel is 5 mm (0.2"), it is important to adjust the switch, so that the arm swing will compress the switch head 5 mm.

### 97-122mm (3.81-4.80")

Follow steps 1 & 2 as described above.

3. Loosen Nut 2 and back up completely the threaded sleeve from the pivot point bolt and remove it from the swing arm. (see figure 3)
4. Remove the swing arm from the pivot point bolt.
5. Remove the two fastening bolts with flat washer holding the guard attached to the swing arm.
6. Remove the slack rope switch from the angular contact bracket.
7. Remove the two bolts connecting the weight blocks to the swing arm and remove the weights.
8. Rotate the swing arm 180 ° along the longitudinal axis, such that sheave is positioned beyond the end of the pivot point bolt (see figure 5).
9. Grease lightly the outside surface of the Threaded sleeve. Insert the Threaded sleeve and rotate to position the sheave at the required distance.
10. Lock the position and the rotation of the Threaded sleeve by tightening the Nut 2.
11. Reattach the protective cover with the two bolts and washer, ensuring that the cover is sitting above the sheave.
12. Positioning the slack rope switch above the swing arm, align the switch head to be centered on the swing arm (see figure 6) and secure the switch with the provided hardware thru the slotted holes to the angular contact bracket.
13. Reattach the weight blocks to the swing arm with the provided hardware. Ensure the orientation of the weight blocks is maintained (see figure 7).

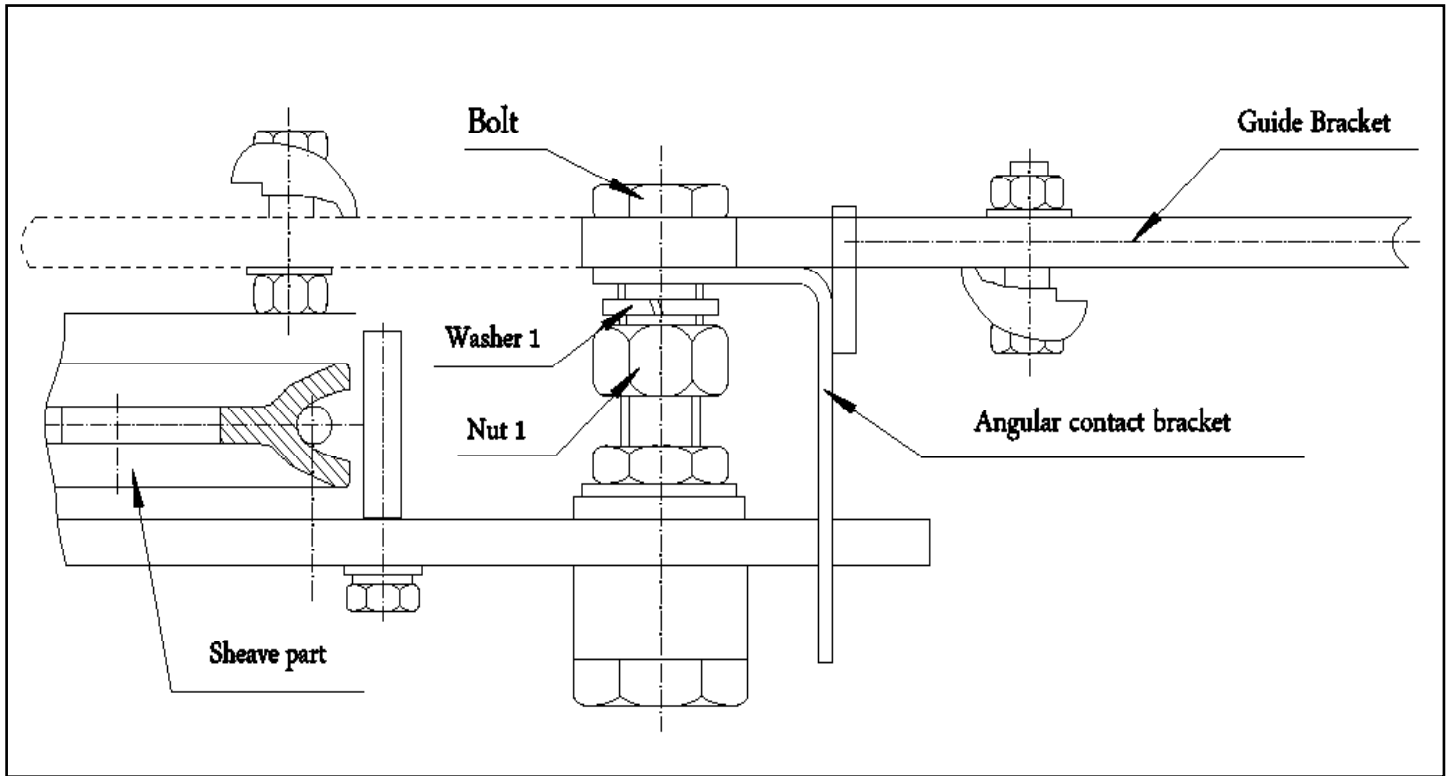

Figure 2

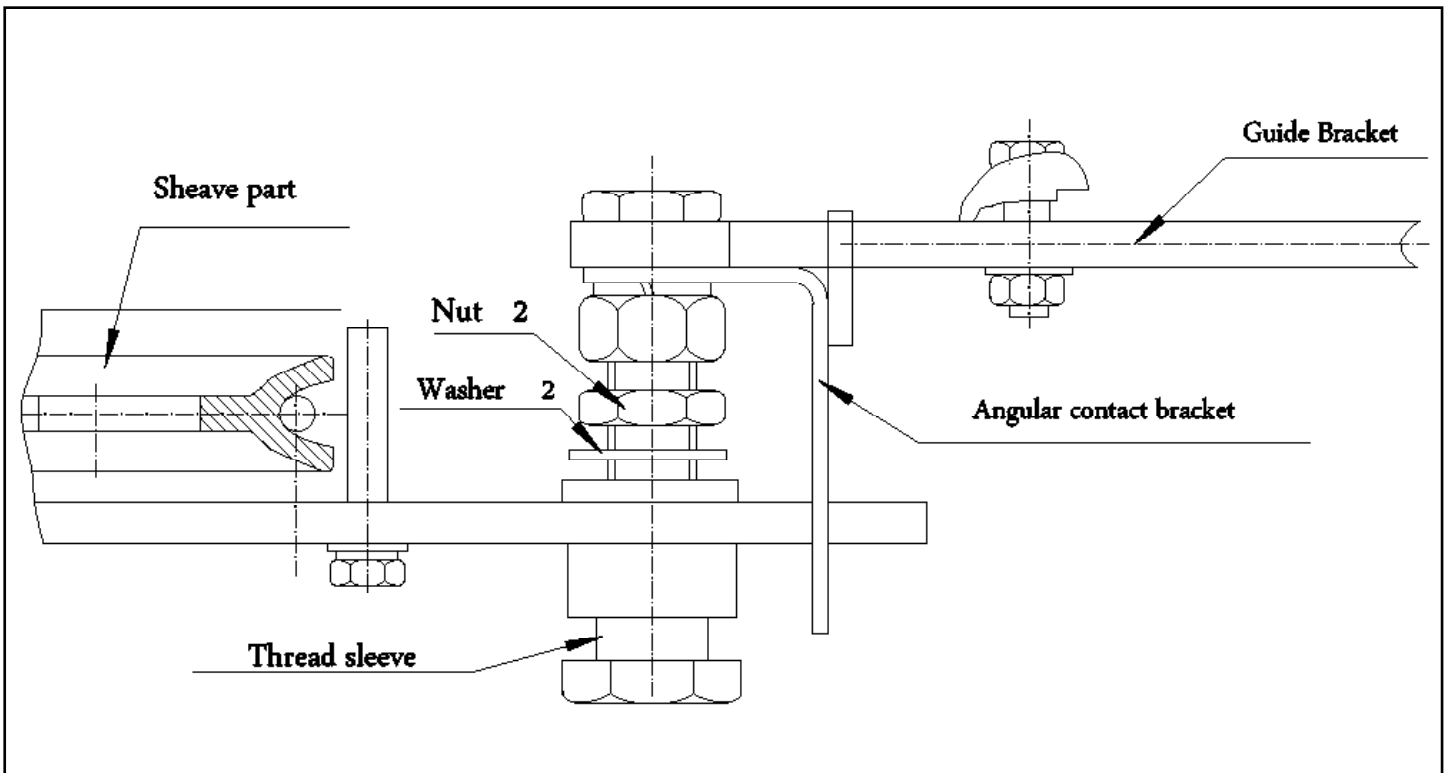

Figure 3

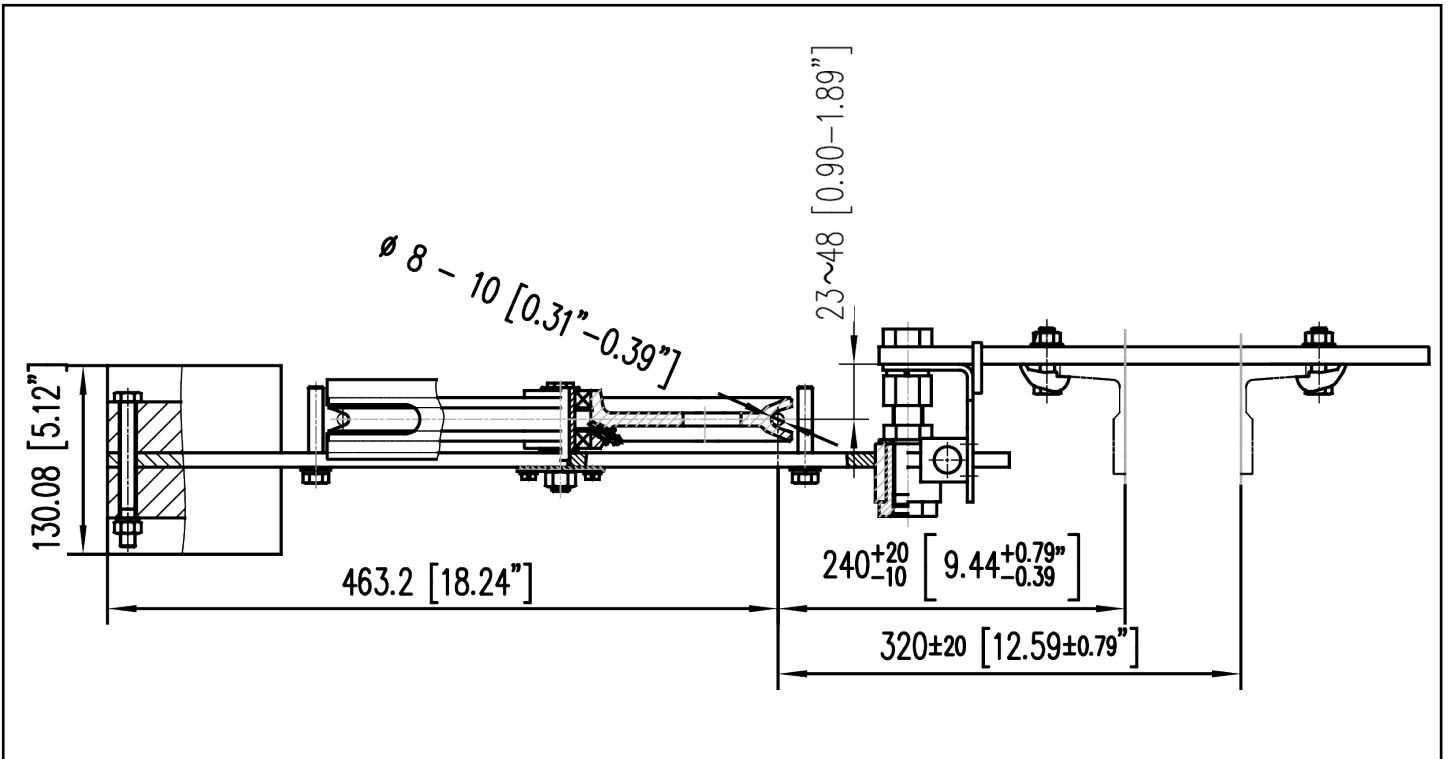

Figure 4

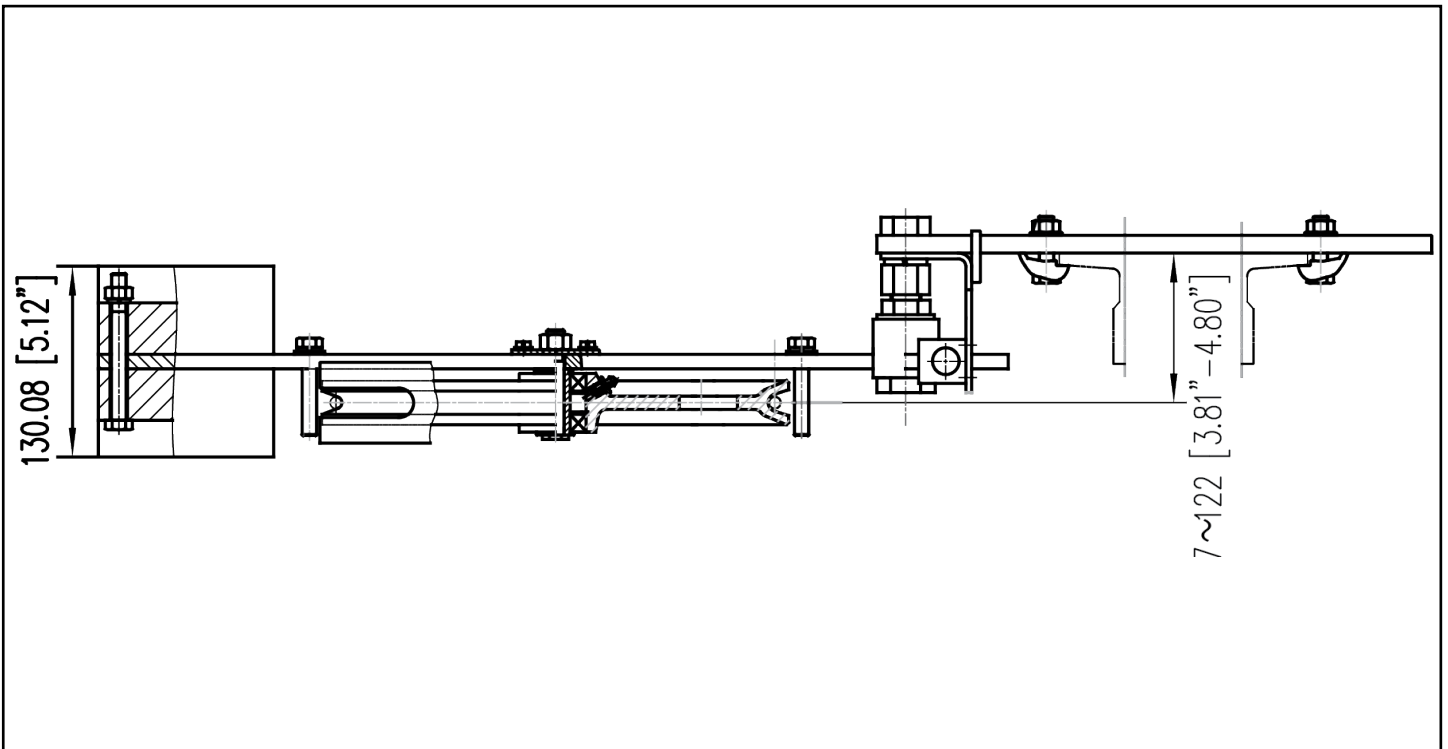

Figure 5

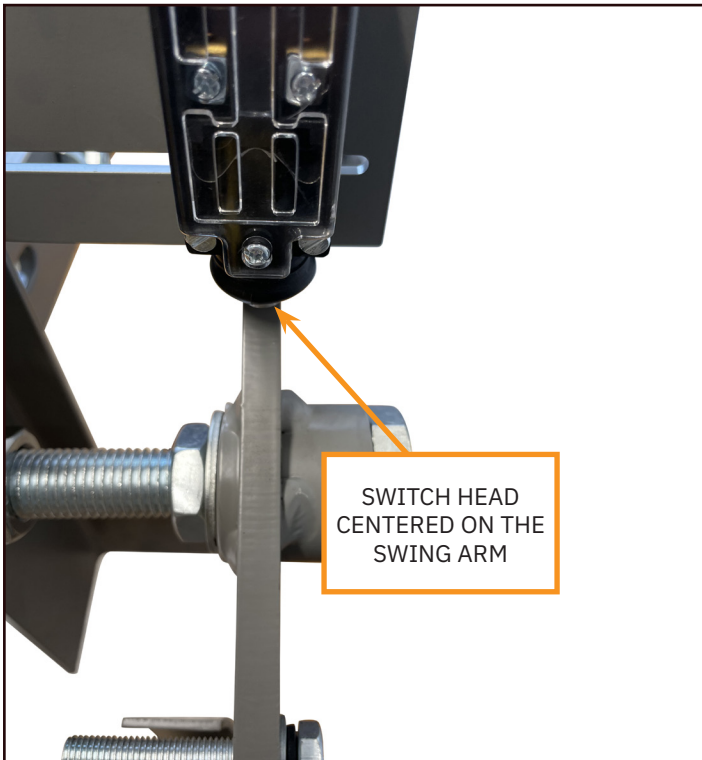

Figure 6

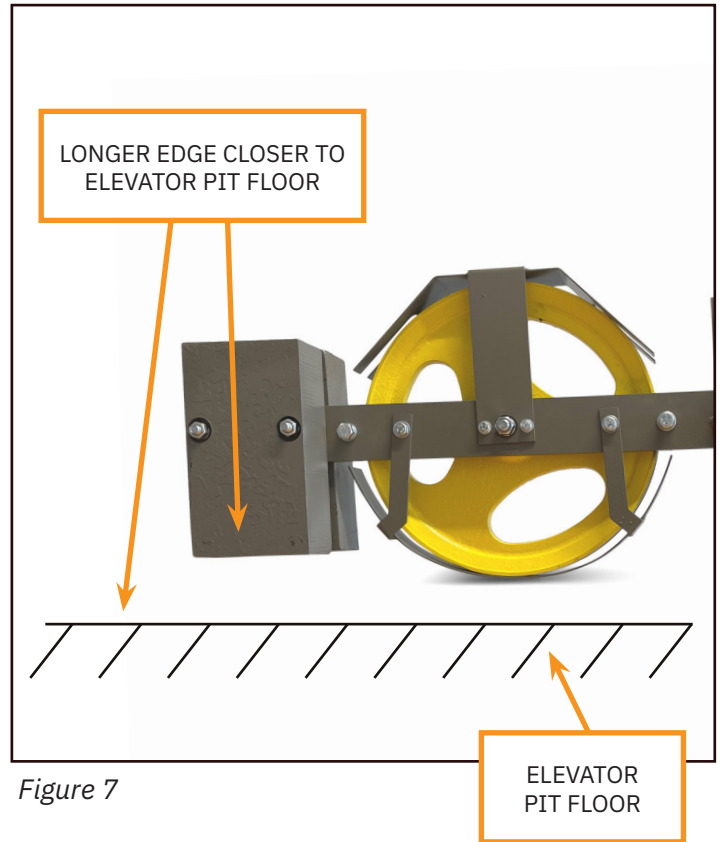

Figure 7

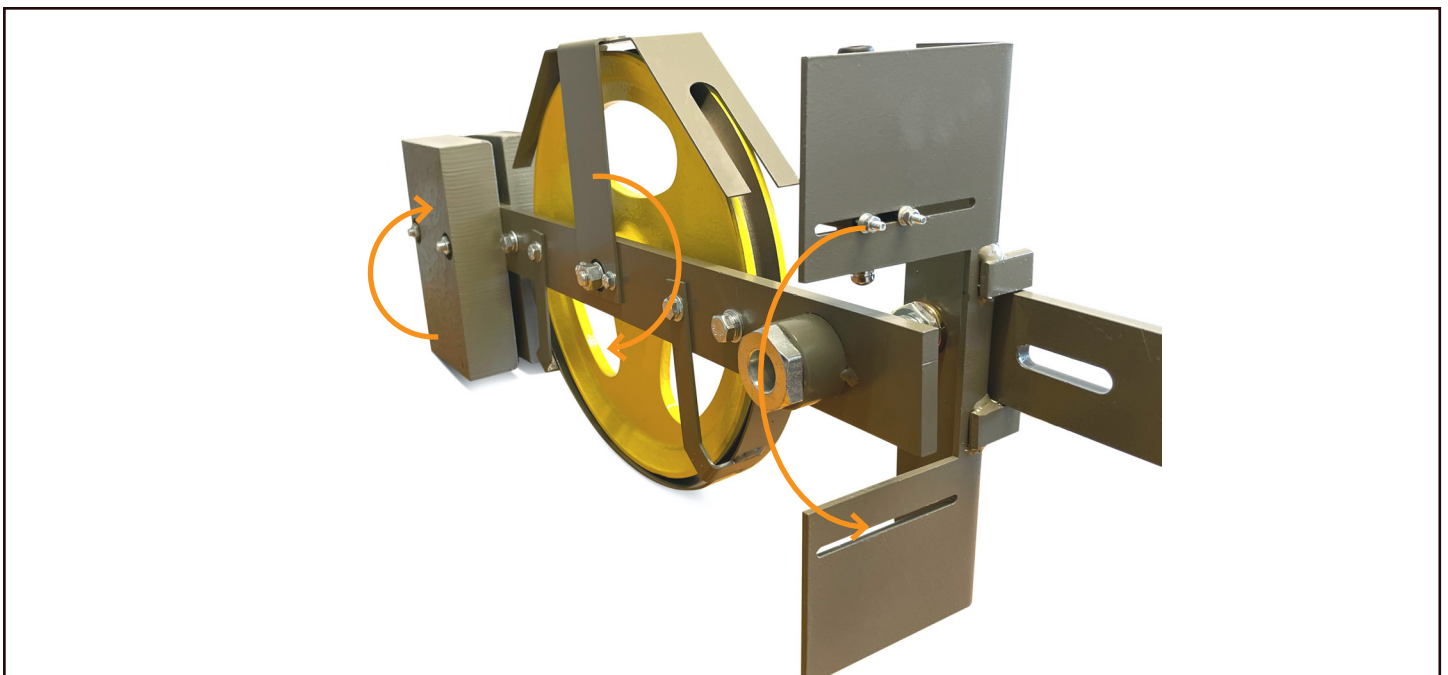

Figure 8

## LEFT Hand Configuration

### 23-48mm (0.90-1.89")

Follow these steps to prepare the unit:

1. Loosen the Nut 1 and back up the nut ~ 16 mm (5/8") to allow the rotation of the guide bracket with 180 ° from initial position (*see figure 2*).
2. Tighten the Nut 1 until the split Washer 1 is fully collapsed.
3. Remove the two fastening bolts with flat washer holding the guard attached to the swing arm and reinstall the guard on the same face but rotated 180°.
4. Remove the slack rope switch from the angular contact bracket and reinstall it on the opposite side. Ensure the switch head is aligned with center of swing arm (*see figure 6*).
5. Remove the two bolts connecting the weight blocks to the swing arm, remove the weights and reinstall rotated 180° (*see figure 8*).
6. To adjust the position of the governor rope center line relative to the base surface of the rail within the 23-48 mm (0.90-1.89") range, loosen Nut 2. (*see figure 9*). Grease lightly the outside surface of the threaded sleeve.
7. Rotate the threaded sleeve to position the sheave at required distance.
8. Lock the position and the rotation of the threaded sleeve by tightening the Nut 2.

### 97-122mm (3.81-4.80")

Follow these steps to prepare the unit:

1. Loosen the Nut 1 and back up the nut ~ 16 mm (5/8") to allow the rotation of the guide bracket with 180 ° from initial position (*see figure 2*).
2. Tighten the Nut 1 until the split Washer 1 is fully collapsed.
3. Loosen Nut 2 and back up completely the threaded sleeve from the pivot point bolt and remove it from the arm (*see figure 3*).
4. Remove the swing arm from the pivot point bolt and rotate 180 ° along the longitudinal axis, so that the sleeve is positioned beyond the end of the pivot point bolt (*see figure 10*).
5. Grease lightly the outside surface of the Threaded sleeve. Insert the Threaded sleeve and rotate to position the sheave at the required distance. Lock the position and the rotation of the threaded sleeve by tightening the Nut 2.
6. Adjust the position of the slack rope switch to ensure the switch head is centered on the swing arm (*see figure 6*).

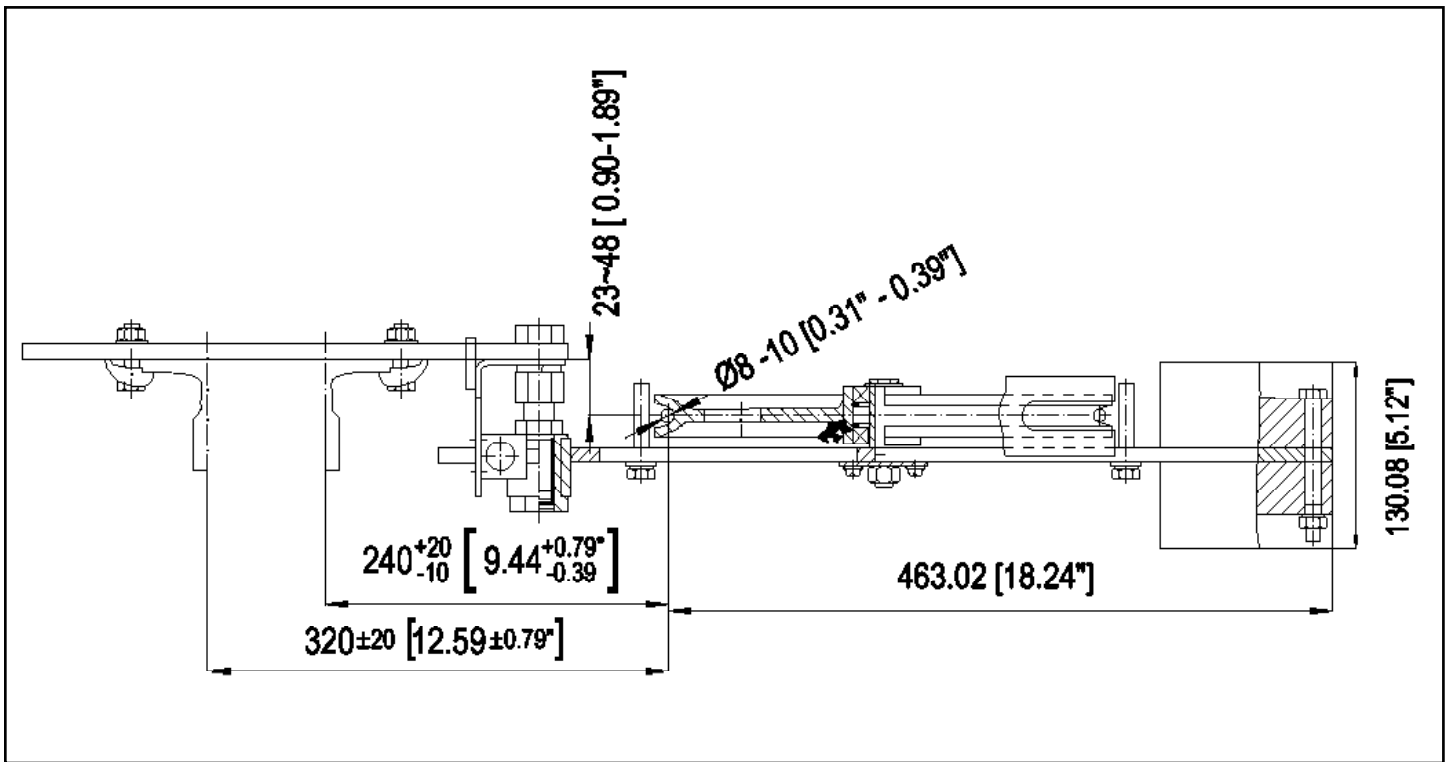

Figure 9

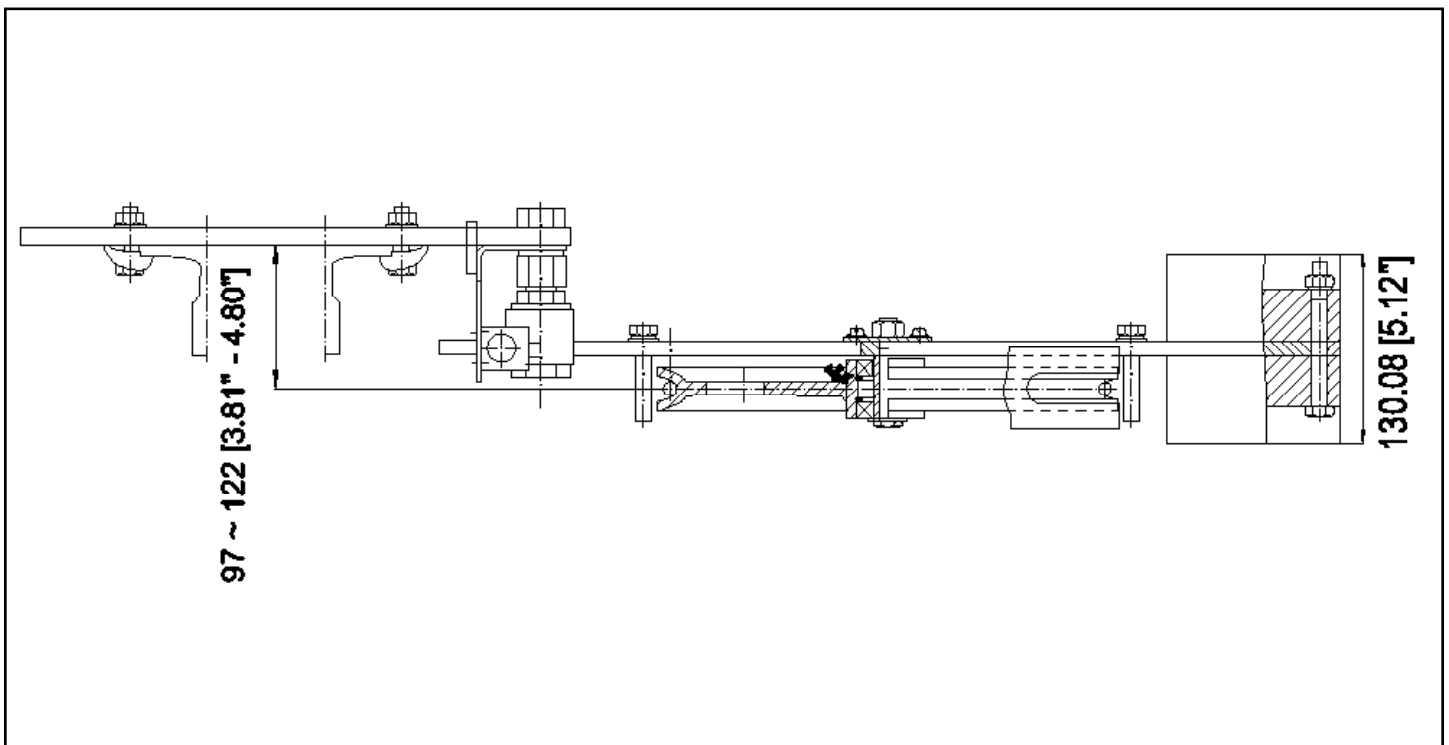

Figure 10

## Mounting Location & Field Verifications

- The Tension Device unit kit contains a set of rail clips, two M10 x 35 Gr8.8 bolts, two M10 washer and two M10 nuts. This hardware will be used to attach the tension device to the car guide rail. The installation has to be done to ensure the governor rope is vertically aligned with the tension device sheave.
- The unit can be configured for a left hand or right hand application. Positioning of the tension device relative to the elevator pit floor at the recommended distance shown on the drawings bellow. (see the next page)
- Before use, make sure the sheave rotates freely. Check the rotation of the tension device on the pivot point (Threaded Sleeve) to ensure free movement.
- Verify the switch head is at the full extended position (contact is open). Verify that wiring of the switch to the elevator controller is done according with the code requirements.

## Lubrication

- The Tension Device has two sealed and greased bearings on the sheave that don't require maintenance.

## LEFT hand configuration

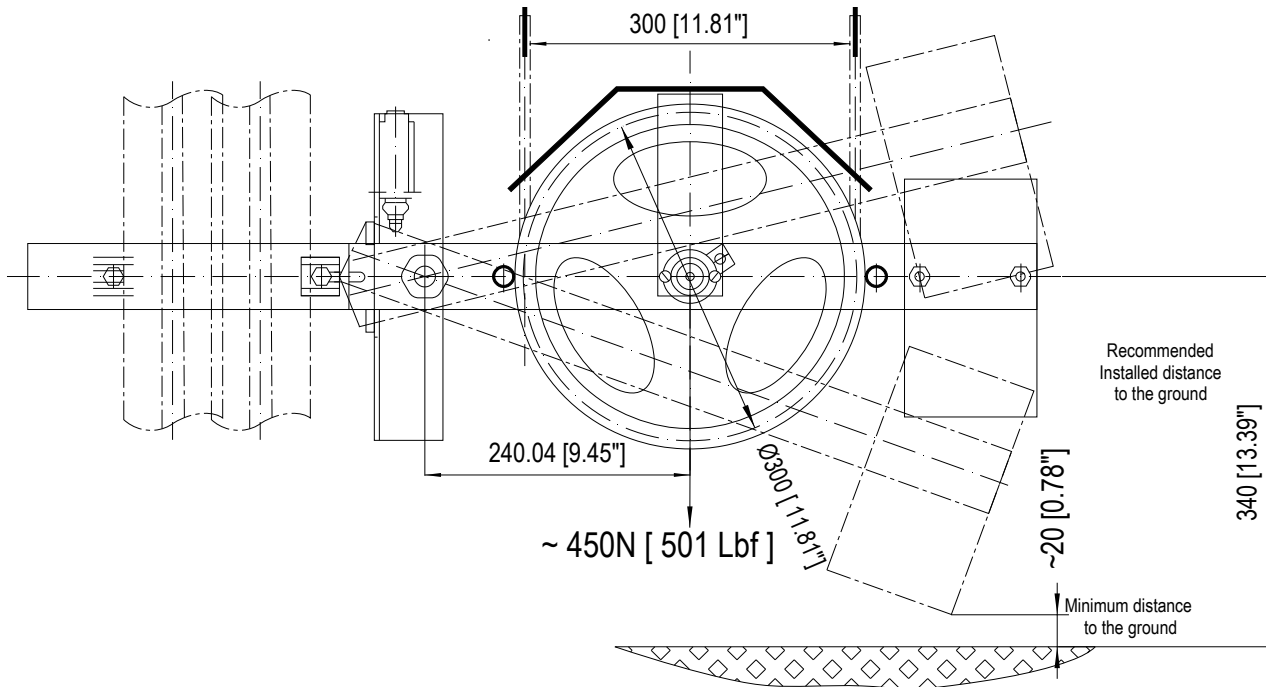

## RIGHT hand configuration

