

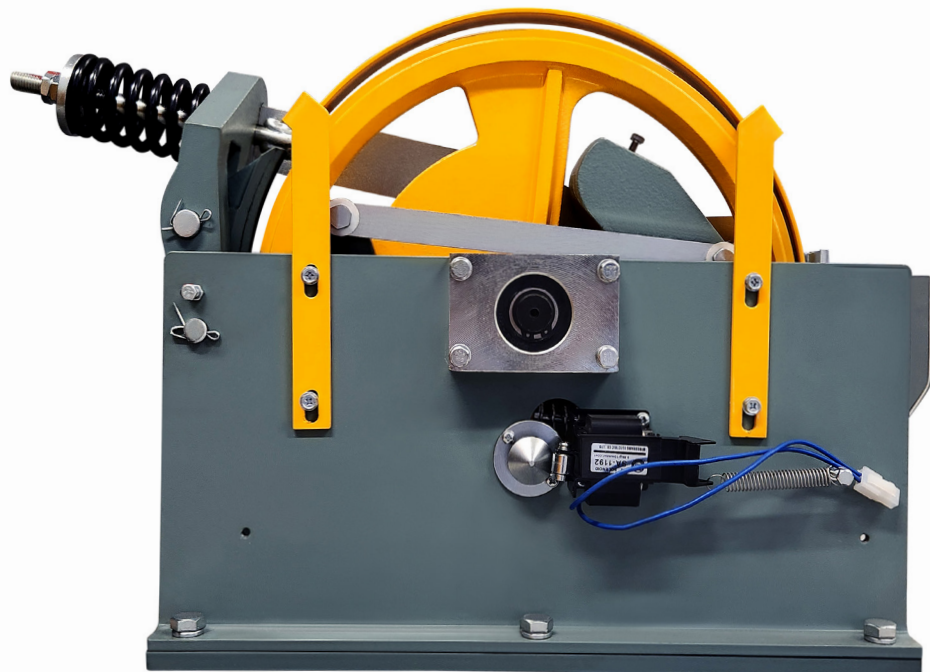

# SELF RESETTING GOVERNOR



[www.delcoelevators.com](http://www.delcoelevators.com)  
[info@delcoelevators.com](mailto:info@delcoelevators.com) | 1-866-900-3727

## CONTENTS

ABOUT DELCO .....	3
HOW TO ORDER.....	3
SPECIFICATION .....	4
General.....	5
Overspeed Switch .....	5
Remote Tripping Solenoid .....	6
Reset Solenoid .....	6
WORKING PRINCIPLE .....	7
Features .....	8
Safety Cover .....	9
Governor Data Plate .....	9
Safety Requirements .....	9
INSTALLATION .....	10
Mounting Location & Alignment .....	10
Fastening to Building Structures .....	10
Electrical Connection.....	12
GOVERNOR RESET .....	13
INSPECTION & TESTING .....	14
General Inspection .....	14
Operational Testing.....	14
MAINTENANCE .....	16
Lubrication .....	16

## ABOUT DELCO

### In Stock, Non-Proprietary, Proven & Competitive

Delco Elevator Products Ltd. has always been a family owned and operated business and is proud to have been helping our customers with elevator components for over 45 years.

With a head office and warehouse in Vancouver, BC, Canada, and a warehouse in Seattle, WA, USA, Delco is strategically located to source, stock and ship elevator products to customers in Canada, the Caribbean and the US.

From Haider machines to popular components, including roller guides, shackles, oil buffers, governors & door edges to a range of elevator parts, the company's comprehensive product selection is one of the reasons that customers have been returning to Delco for decades.

Another reason is that we are very good at ensuring that the right items arrive at the right time to elevator contractors across North America.



Delco's dedicated, experienced and enthusiastic team works diligently to provide exceptional service in the following key areas:

- **In Stock:** We keep our components stocked to make sure that customers receive what they need, when they need it.
- **Non-Proprietary:** Delco's products are universal – perfect for modernizations.
- **Proven Products:** Delco manufactures and distributes products that are tried, tested and proven in the field.
- **Compliant:** Delco products and equipment meet all elevator industry compliance and certification standards.
- **Value for Money:** In a highly competitive marketplace, Delco provides the best quality elevator equipment at the lowest possible prices.
- **Personal, Knowledgeable Staff and Service:** Always on hand to assist you with your unique requirements!

## HOW TO ORDER

**Delco services elevator contractors and OEMs in Canada, the Caribbean and the US, including Puerto Rico and Hawaii.**

We'd love to hear from you and give you a quote on your next project. **Call, email or visit us today!**

OFFICE & WAREHOUSE CANADA  
#205-3765 1st Avenue  
Burnaby, BC V5C 3V8

WAREHOUSE USA  
2302 West Valley Highway North,  
Suite 300, Auburn, WA 98001

**Phone: 1.604.904.3727 - CAN/USA**  
**Toll Free: 1.866.900.3727**  
**Email: [info@delcoelevator.com](mailto:info@delcoelevator.com)**  
**[www.delcoelevator.com](http://www.delcoelevator.com)**

We look forward to welcoming you to our family of customers and friends.

## SPECIFICATION

The main function of the SGL Governor is to detect the increase of the elevator car speed over a code prescribed limit and initiate the trigger the safe stopping of the elevator car.

This governor is designed and built to meet both CSA B44 and ASME A17.1 code specification.

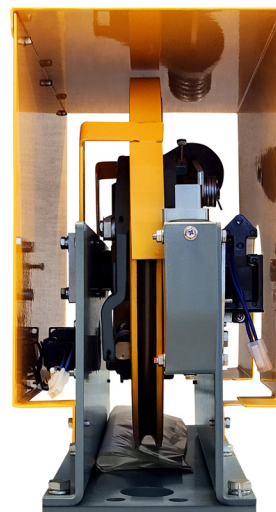
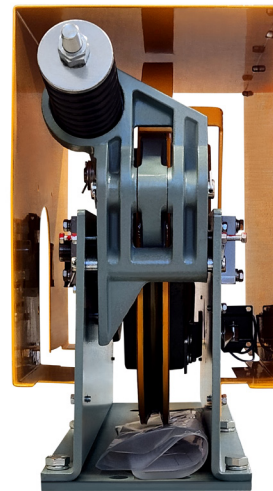

# SELF RESETTING GOVERNOR



## General

Car rated speed range	0.50-2.54 m/s	100-500 FPM
Maximum Mechanical Tripping Speed	Conforms to requirements in table 2.18.2.1 CSA-B44/ANSI 17.1	
Maximum Car speed at which Governor Overspeed switch operates down	Conforms to requirements in table 2.18.2.1 CSA-B44/ANSI 17.1	
Governor hand	Left or right	
Sheave Pitch Diameter	305 mm	12 inch
Rope Diameter	9.5 mm or 10 mm	3/8 inch or 10 mm
Rope Type	Traction Steel 8 X 19	
Pre-set Pull Through	1780 N	400 Lbs
Maximum Pull Through	2940 N	660 Lbs
Over Speed Switch	YES	
Remote Tripping	YES(optional)	
Remote Reset	YES(optional)	
Live encoder shaft diameter (Optional)	20 mm OD with 8 mm bore	0.789 inch OD with 0.314 inch bore
Protective cover	YES	

## Overspeed Switch Specification

Switch part number	DEL-S3-1375
Manufacture	Shanghai Huasheng Electric Co.
Contact type	2NC- normal closed spring loaded
Frequency	50/60 Hz
Rating	110 Vdc-3 A ; 220 Vac- 5 A, 380 Vac- 4 A
Ambient Temperature	-25 °C to +70 °C
Relative Humidity	<90%
IP Rating	IP54

# SELF RESETTING GOVERNOR



## Remote Tripping Solenoid Specification

Actuator type	Push -pull
Manufacturer & model number	SA-1192
Operating Voltage	AC-110V/50HZ
Rated Force	0.8Kg ( 1.7 Lbs)
Nominal Stroke	10 mm ( 0.393 inch)
Coil resistance	58.2Ω(for reference only-to be verified)
Ambient Temperature Rating	-10~70°C
IP Rating	No rating

## Reset Solenoid Specification

Actuator type	Push -pull
Manufacturer & model number	SA-1192
Operating Voltage	AC-110V/50HZ
Rated Force	0.8Kg ( 1.7 Lbs)
Nominal Stroke	10 mm ( 0.393 inch)
Coil resistance	58.2Ω(for reference only-to be verified)
Ambient Temperature Rating	-10~70°C
IP Rating	No rating

This governor should only be used in application with the maximum specified speed on the data tag. This type of governor is designed for indoor applications only.

Running Speed		Max Overspeed Switch Setting		Max Mechanical Tripping Speed	
FPM	M/S	FPM	M/S	FPM	M/S
0-125	0-0.64	158	0.80	175	0.89
150	0.76	189	0.96	210	1.06
200	1.02	252	1.28	280	1.42
250	1.27	303	1.54	337	1.71
300	1.52	353	1.79	395	2.01
350	1.77	407	2.07	452	2.30
400	2.03	459	2.33	510	2.59
500	2.54	563	2.86	625	3.18

## WORKING PRINCIPLE

- The Self Resetting Overspeed Governor is a centrifugal type with a horizontal shaft. The simple construction provides a short response time, reliability in operation and minimal space requirement for installation.
- This governor has two pivoting flyweights connected with a solid link to ensure simultaneous movement (see figure 1). The movement of the flyweights is controlled with a helical spring system (see figure 2). As the governor pulley rotates in the vertical plane, driven by the governor rope movement, the flyweights are driven outward due to the centrifugal force and compressing the calibrated spring assembly.
- In the down direction, when the governor pulley rotation exceeds the rated speed, by a set value, the outward movement of the flyweights will trip an overspeed switch that will send an electrical signal to the elevator control system to initiate an emergency shut down. If the elevator continues to move and the speed continues to increase, the movement of the flyweights will cause the pawl to engage the ratchet and thru the spring loaded shoe linkage will engage the governor shoe on to the governor rope to stop it (see figure 3). The increase in the governor rope tension will actuate the car safety assemblies, which will clamp on to the guide rails and mechanically stop the elevator.

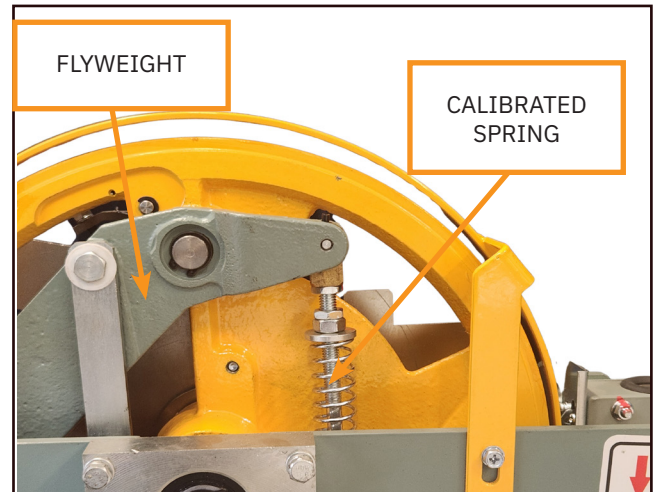

Figure 2

- In the up direction, when the governor pulley rotation exceeds the rated speed, by a set value, the outward movement of the flyweights will trip an overspeed switch that will send an electrical signal to the elevator control system to initiate an emergency shut down. If the speed continues to increase in the up direction, the governor will not engage the car safety assembly. In this instance a different ascending protection method is required to stop the unintended motion.

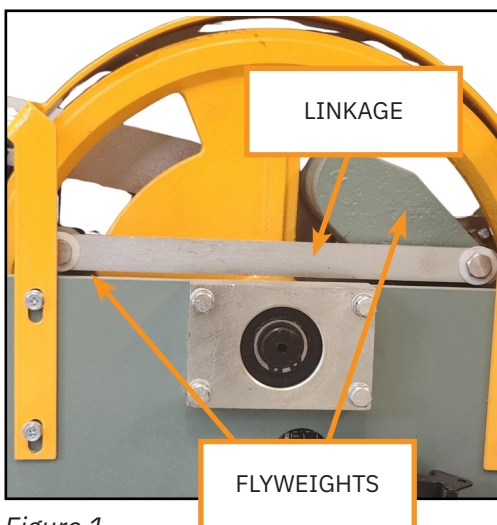

Figure 1

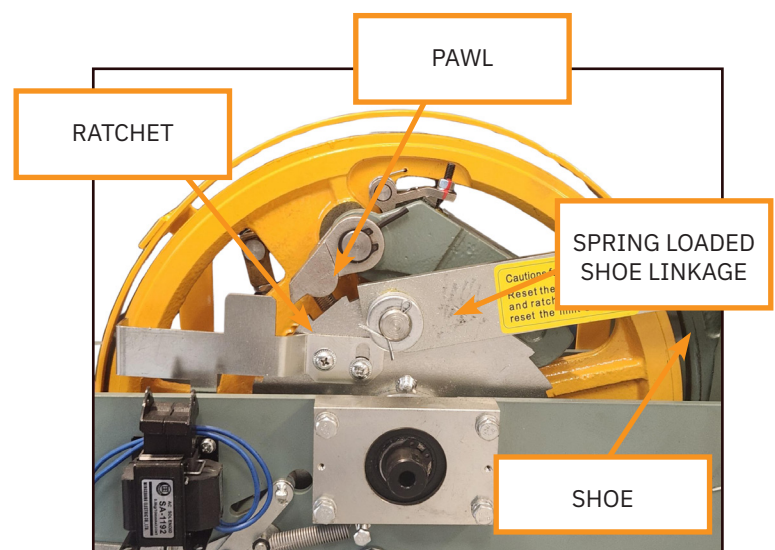

Figure 3

## Features

The SGL Governor has the following optional features:

1. Remote tripping – thru a solenoid and a pin mechanism (see figure 1) the governor can be tripped remotely. This function is design to allow the tripping of the governor at lower speeds than the normal over-speed speed of the governor, in order to check the functionality of the governor.

To perform the remote tripping function, a control signal and AC 110V power has to be connected to the solenoid. Perform whit operation with the elevator in “INSPECT” mode only. After remote tripping follow the instructions for the governor reset.

2. Remote reset – thru a solenoid and a proprietary mechanical linkage system the governor can be mechanical and electrically reset (see figure 2).

To perform the remote reset function a control signal and AC 110V power has to be connected to the solenoid.

3. Mounting holes for the installation of encoder on the live shaft of the governor. The encoder shaft has to be adapted to mate with the existing 8 mm hole in the governor sheave shaft. For hollow shaft type encoders, few types of encoder shafts adaptors (see figures 3&4), are available, as separate items for purchase, from Delco.

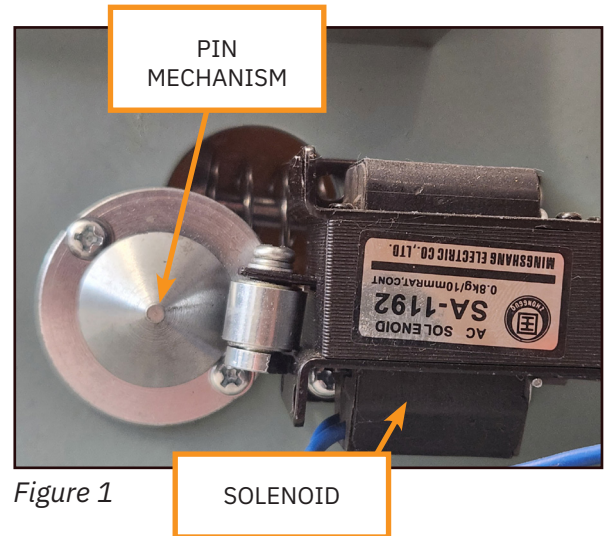

Figure 1

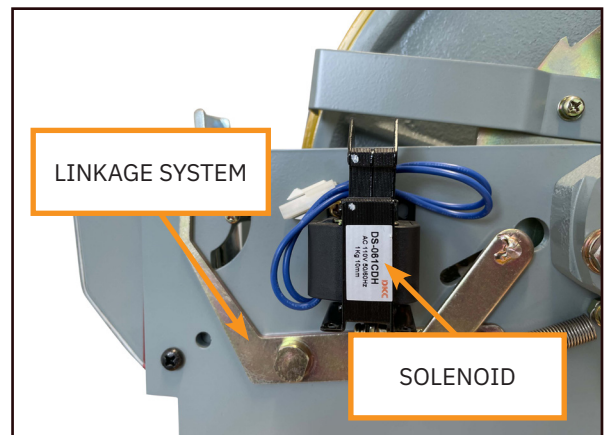

Figure 2

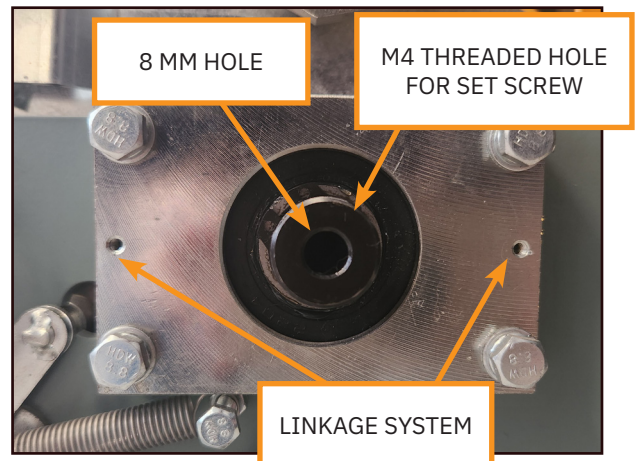

Figure 3



Figure 4



# SELF RESETTING GOVERNOR

## Safety Cover

The governor is provided with a full guard (see figure 1).



The cover is secured to the governor housing with 4 X M5 wing-head thumb screws. To remove the cover just loosen the 4 screws.

To secure the cover to the governor turn the four wing-head thumb screw until snug tight .



Figure 1

## Governor Data Plate

		<b>MODEL: XS19-SGL</b>			
		<b>PRODUCT NO. 24019087</b>			
<b>CAR SPEED</b>		<b>SWITCH SPEED</b>		<b>TRIP SPEED</b>	
<b>0.75</b>	<b>M/S</b>	<b>0.96</b>	<b>M/S</b>	<b>1.07</b>	<b>M/S</b>
<b>150</b>	<b>FPM</b>	<b>189</b>	<b>FPM</b>	<b>210</b>	<b>FPM</b>
<b>ROPE DIAMETER</b>		<b>PULL THRU</b>			
<b>9.5</b>	<b>MM</b>	<b>1780</b>	<b>N</b>	<b>DO NOT LUBRICATE</b>	
<b>3/8</b>	<b>IN</b>	<b>400</b>	<b>LBS</b>	<b>GOVERNOR ROPE</b>	
<b>ROPE 8x19 WARRINGTON TRACTION STEEL</b>					

The governor data plates are located on the front and back face of the governor.

## Safety requirements

- Installation of the governor should be done by qualified and certified personnel.
- Adequate personal protective equipment must be worn for the installation.
- Tools and equipment used for the installation must be inspected and in good condition for the work.
- National and local, governing elevator safety requirements must be followed.
- Read and understand the product installation instructions, provided with the unit, before proceeding.
- For the safe operation of the governor, the governor rope must be kept dry all the time.
- Lubrication of the rope is not permitted.

## INSTALLATION

### Mounting Location & Alignment

1. Determine the governor cable drop locations (match existing layout or use applicable job layout plans).
2. Orient governor with the yellow arrow close to the guide rail and align sheave with the governor rope drops. Make sure the cable drop on the car side rope attachment is a straight drop from the sheave. Notice the governor shoe will be opposite to the car side rope attachment.
3. Verify that adequate clearance exists around the governor for operating without interference with other elevator equipment or support surface.
4. Use a plumb line from the governor sheave to align the idler sheave of the rope tensioner assembly in the elevator pit.
5. Ensure routing of the electrical wire and conduit for the overspeed switch, tripping and reset solenoids and encoders (if applicable) will not interfere with the governor operation or ease of removal.
6. Use the holes pattern in the governor base as a template, or use the 1:1 paper template provided in the kit to mark the locations for the mounting hardware on the machine room floor or supporting surface. If the governor is used in a retrofit project, it is possible that the existing mounting pattern will not align with the mounting holes pattern in the governor, in this case a custom adaptor needs to be designed.

**\*See next page for reference dimensions left hand and right hand governor.**

### Fastening To Building Structures

After mounting holes location has been determined, drill holes in the marked locations.

**Minimum recommended grades for hardware as follow:**

- certified zinc plated anchor bolts and ASME B18.2.2 (or better) zinc plated nuts for installation in concrete floors.
- ASME B18.2.1 (or better) zinc plated bolts and ASME B18.2.2 (or better) zinc plated nuts for installation on metal support structures.

Customer is responsible for selecting adequate size of hardware to secure the governor in place.

# SELF RESETTING GOVERNOR

## Base Print

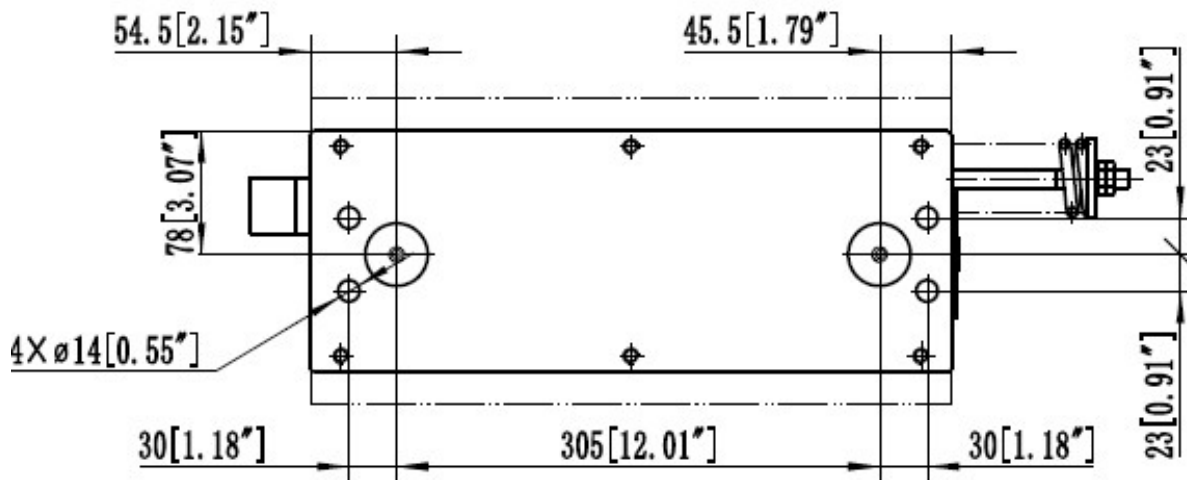
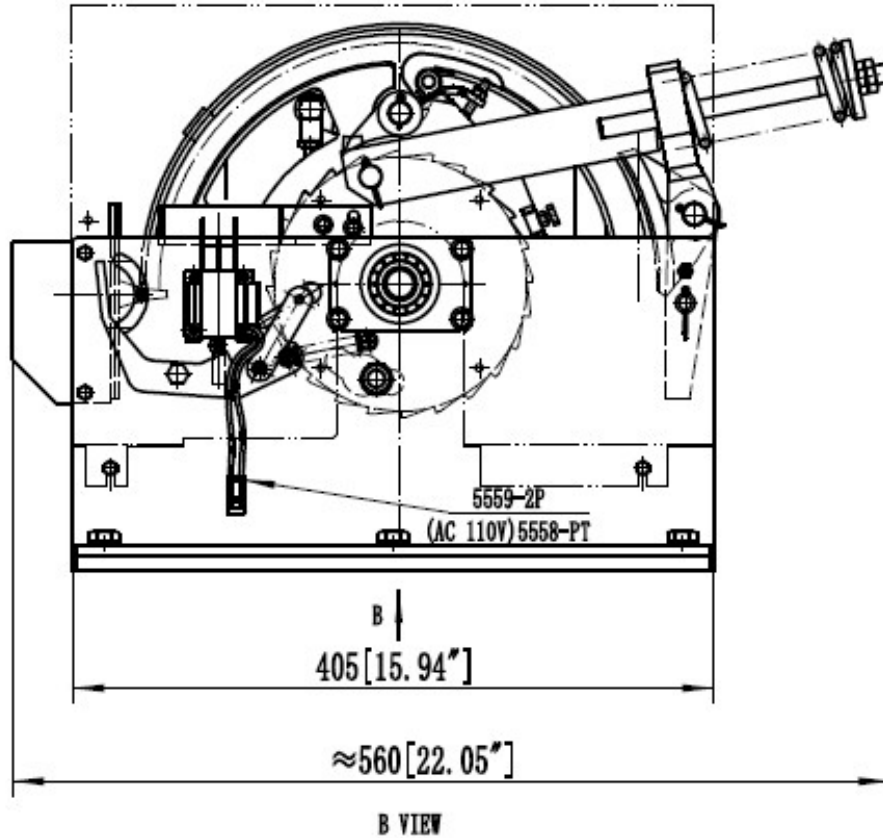

## Electrical Connection

1. The SGL governor CSA approved overspeed switch, is factory installed in the governor. It has to be connected using CSA approved anti-shorts and insulated eyelet crimp on connectors (see figure 1).

The flexible metal conduit is to be terminated in a CSA or UL approved junction box (not included) mounted adjacent to the governor.

The ground wire is to be connected and secured in the junction box and to the grounding stud, provided in the governor the switch enclosure.

CSA or UL approved ground wire and hook up wires must be connected to the controller through the flexible metal conduit or electrical metallic tubing (EMT) to meet local electrical codes.

2. Remote tripping solenoid and remote reset solenoid

All the wires connecting to the solenoids must be installed in a flexible conduit to protect them. Wires used and installation method should meet all the applicable codes. See figure 2 for an example of wiring diagram.

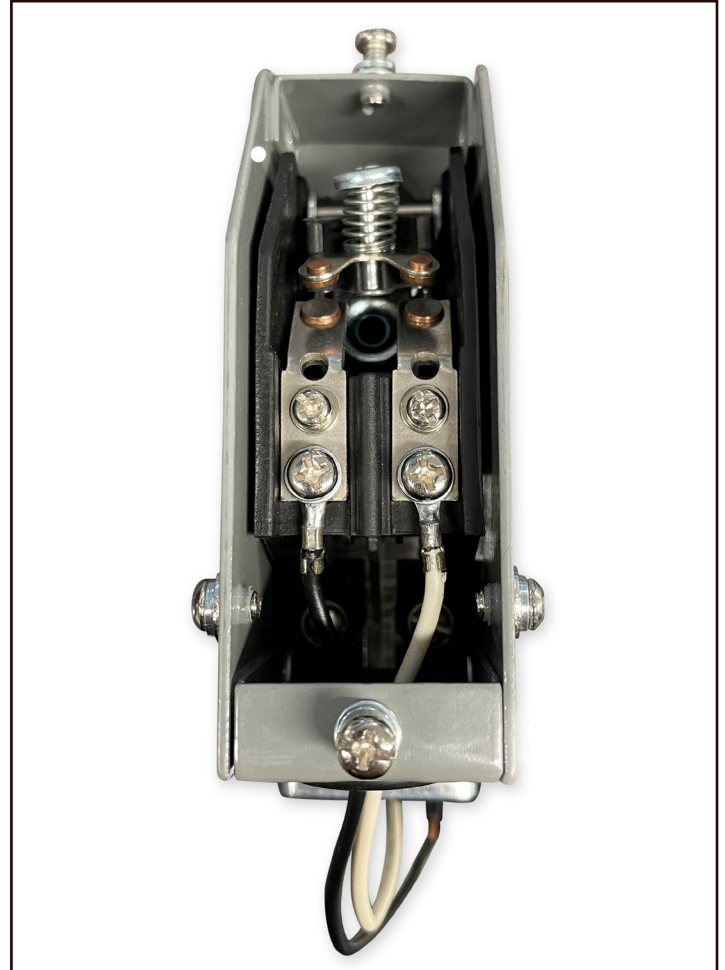

Figure 1

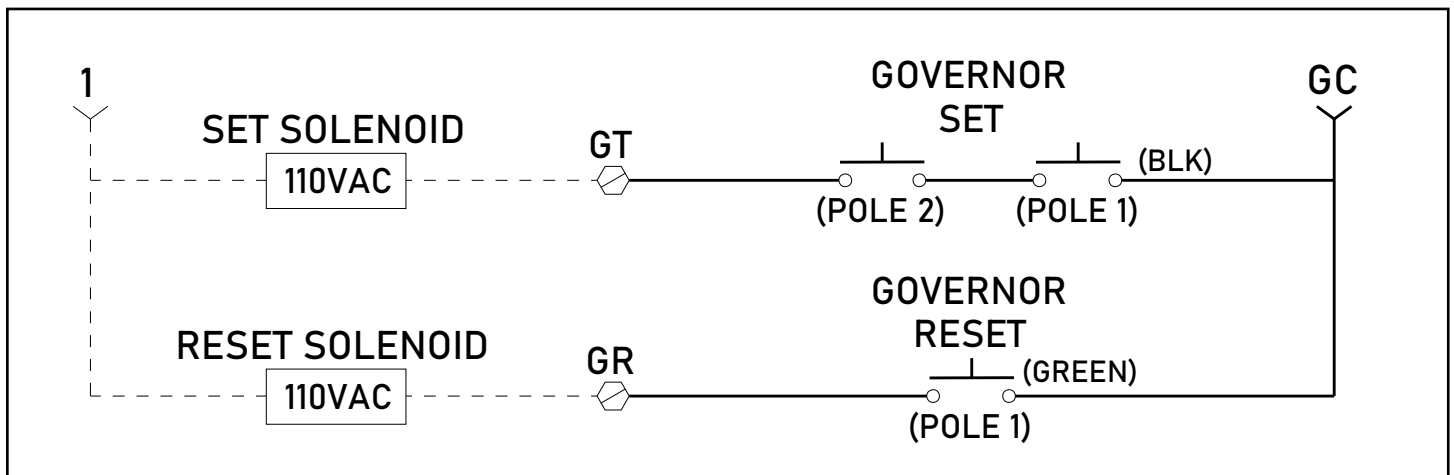

Figure 2

## GOVERNOR RESET

After the elevator has experienced an overspeed condition in which the governor has tripped and set off the safety devices, or the remote tripping function has been used to trip the governor and car stopped, it will be necessary to reset the governor after the elevator has been deemed safe for operation.

To reset the governor remotely follow this sequence:

- With the elevator in “Inspect” mode, move the car in the “UP” direction slowly until the safeties released the rails. During this operation DO NOT energize the governor reset solenoid.
- After the safeties have released, energize the reset solenoid, and run the car in the “UP” direction slowly, until the governor sheave has made two complete 360 degree turns. The proprietary mechanical linkage system connected to the reset solenoid (see figure 1) will return the overspeed switch trip arm to a horizontal position (ready state) and the pawl will be moved away from the ratchet and secured in a ready position. At this point, the governor is mechanically and electrically reset, and the reset solenoid must be de-energized.

To reset the governor manually (if no remote reset option available):

- With the elevator in “Inspect” mode, move the car in “UP” direction for the safeties to release from the rails.
- Once safeties have been released, move the car in the “UP” direction slightly and stop when the pawl disengage from ratchet (see figure 2). Press on the pawls pin to move the pawl away from the ratchet until a click sound is heard. At this point, the pawl is secured in the “UP” position above the ratchet and has been reset.
- Reset the overspeed switch by moving manually the trip arm to horizontal position (see figure 3).

Always release the pawl from the ratchet first, before resetting the overspeed switch.

Before resuming operation, ensure the car safeties had released the rails.

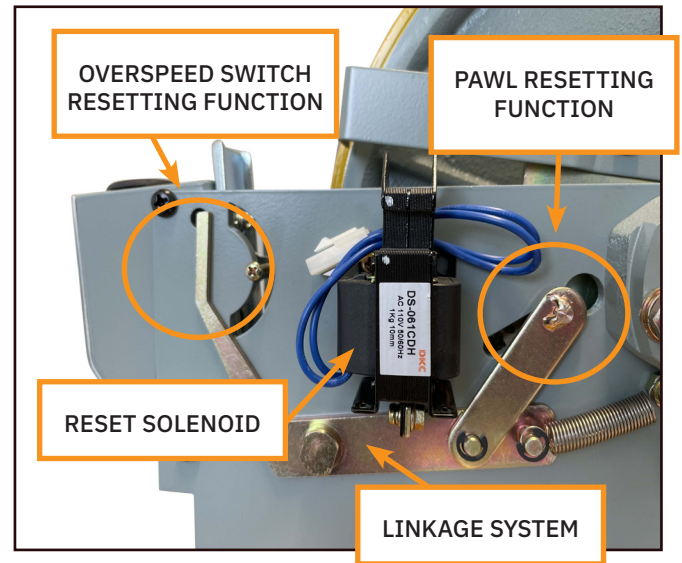

Figure 1

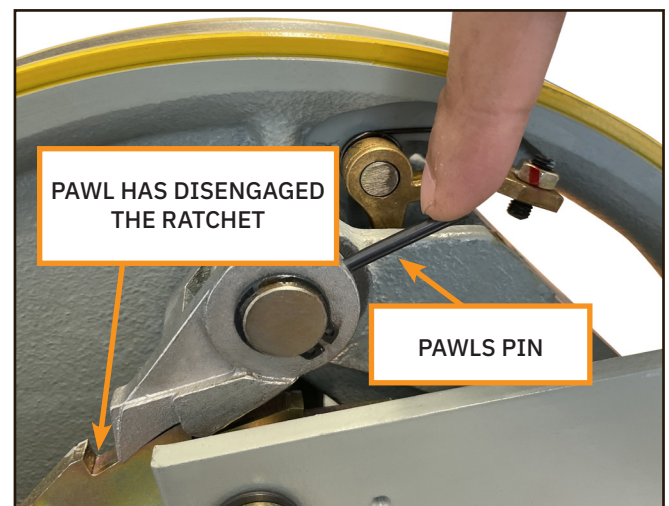

Figure 2

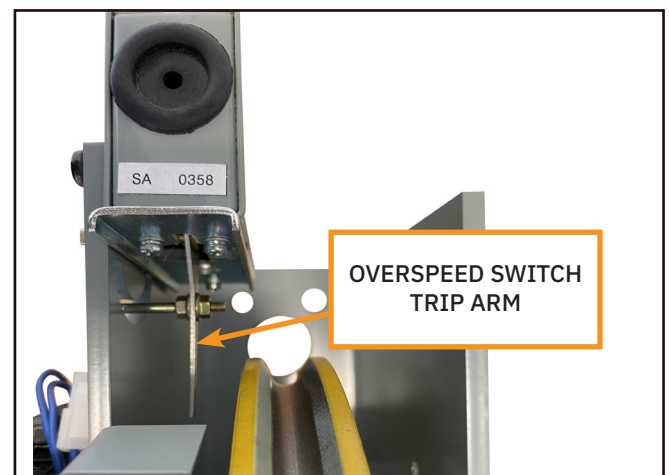

Figure 3

## TESTING

### General Inspection

- Ensure governor is securely fastened in place to the bench or work surface.
- Examine all linkages , pins, shafts , bearings, bushings, connecting the flyweights to the sheave and the rope gripping device.
- Manually move the flyweights, pawl and the sheave to ensure they move and operate freely.
- Check that there is enough room for the rotation of the fly weights in their extreme extended position.
- Inspect rope gripping surfaces ( sheave groove and shoe groove) to ensure that are free of obstruction or any foreign substances ( paint, grease etc).
- The governor is provided with an overspeed switch, move manually the trip arm of the switch from the horizontal position to a vertical position to ensure it operates freely.

### “DOWN” Direction - electrical and mechanical tripping

- Check the sheave is rotating freely.
- Check the trip arm of overspeed switch is in horizontal position.
- With a rubber drive wheel held against the governor sheave outside face (*see figure 1*), slowly and gradually accelerate the governor sheave to rotate in the direction indicated by the arrow painted on the housing until it trips the electrical switch (the trip arm is not horizontal and the electrical contact is open).
- Continue to engage the sheave with the rubber drive wheel and slowly increase the speed of the drive unit until the governor is mechanically tripped (pawl has engaged the ratchet).

### “UP” Direction - electrical tripping only

- Check the sheave is rotating freely.
- Check the trip arm of overspeed switch is in horizontal position.
- With a rubber drive wheel held against the governor sheave (*see figure 1*), slowly and gradually accelerate the governor sheave to rotate in the opposite direction indicated by the arrow painted on the housing until it trips the electrical switch (the trip arm is not horizontal and the electrical contact is open). At this point the testing will be stopped since in the “UP” direction the mechanical tripping is not operational.

### “DOWN” Direction -remote tripping

- Check the sheave is rotating freely.
- Check the trip arm of overspeed switch is in horizontal position.
- Ensure that the remote tripping solenoids is energized and a control switch is connected to control power to the solenoid. Make sure the solenoid is not energized when the test is done.
- With a rubber drive wheel held against the governor sheave (*see figure 1*), slowly and gradually accelerate the governor sheave to spin in the direction indicated by the arrow painted on the housing.
- Energize the remote tripping solenoid , this should mechanically trip the governor ( pawl will engage the ratchet).

# SELF RESETTING GOVERNOR

## Operational testing on the bench for the remote reset

- Check the sheave is rotating freely.
- Check the trip arm of over-speed switch is in horizontal position.
- Ensure that the remote reset solenoid is energized, and a control switch is connected to control the supply of power to the solenoid. Make sure the solenoid is not energized when the test is done.
- With a rubber drive wheel held against the governor sheave (see figure 1), slowly spin the governor sheave in the opposite direction of the one indicated by the arrow painted on the housing (“UP” direction of the car).
- Energize the remote reset solenoid, and continue to spin the sheave at least two full turns until pawl will be moved away from the ratchet. In the same time the trip arm of the over-speed switch will be returned to horizontal position. At this point the test should be stopped.

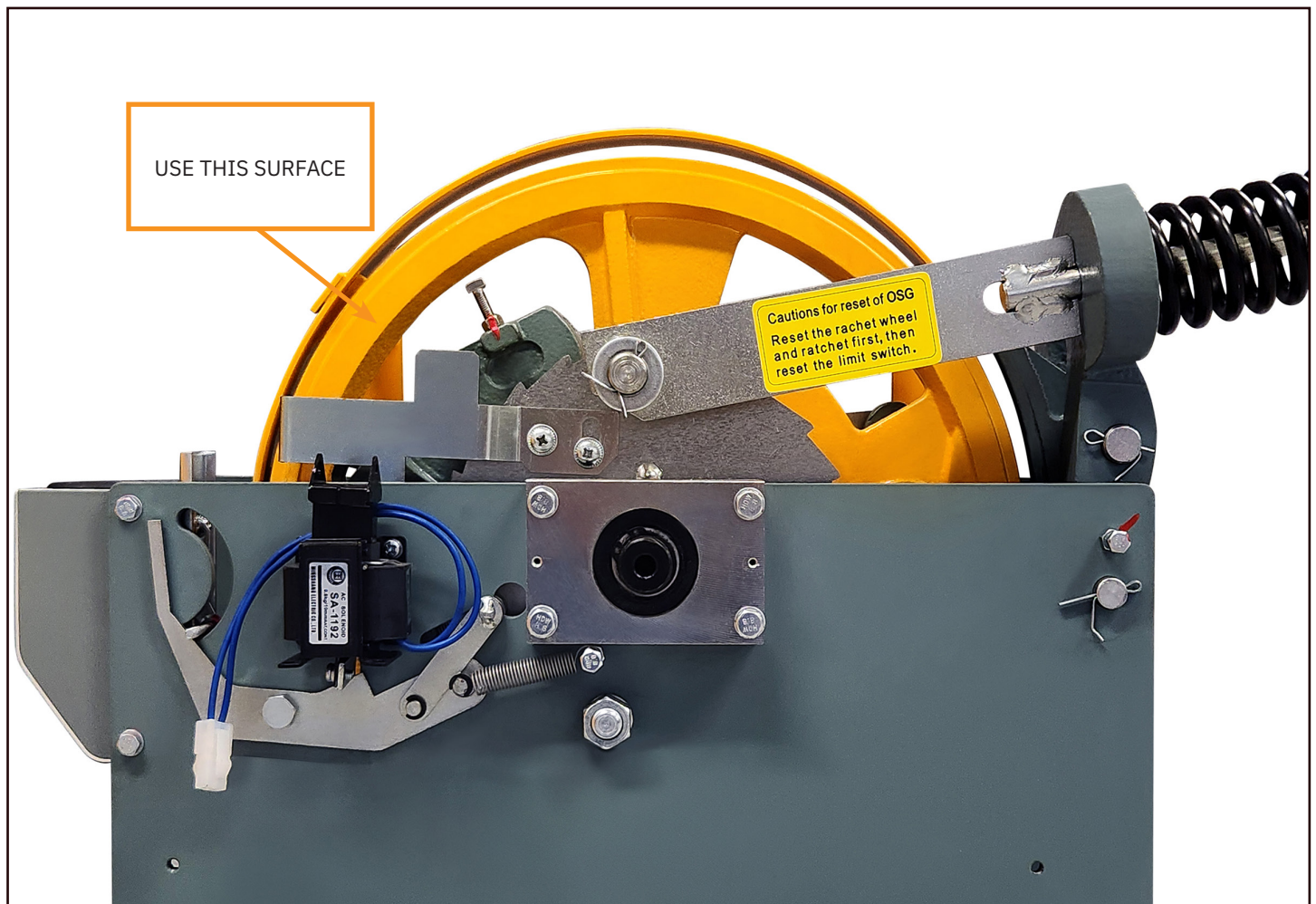

Figure 1

## MAINTENANCE

### Quarterly :

- Check visually all the linkages, springs, split rings and other fasteners to ensure they are not missing or becoming loose.
- Clean the governor groove and wire ropes to remove extra grease.
- Visually check the fastening of the governor to the support structure.

### Every year:

- Perform periodical inspections and tests in accordance with the National Elevator Code (CSA B.44 or ASME 17.1) and the applicable local elevator codes to ensure the governor is in good condition and operates properly.
- Check the functionality of the overspeed switch from a mechanical and electrical point of view.
- Check the operation of the remote tripping and remote reset devices from a mechanical and electrical point of view.

### Lubrication

The governor uses sealed and packed bearings to ensure a maintenance free product.

### Every 6 months:

- Visually check the pawl, ratchet, sheave groove and governor shoe for signs of significant wear of damage.
- Inspect the governor rope to follow inspection procedure recommended by the rope manufacturer.

### Every two years:

- Test and verify rated and tripping speed.