

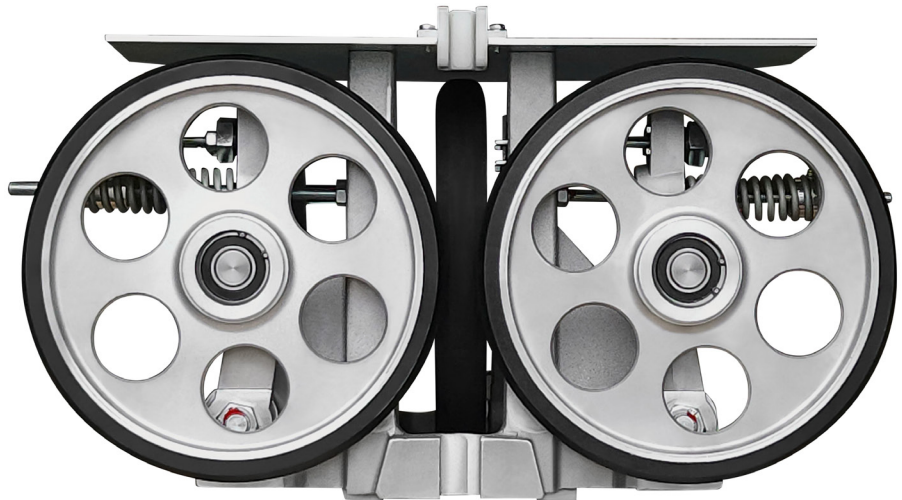

12" HIGH SPEED ROLLER GUIDE ASSEMBLY



CONTENTS

| | |
|---|----|
| 1. General..... | 3 |
| 2. Adjustment of the position of the roller guides..... | 4 |
| 3. Adjustment of the springs and the movement limiters..... | 6 |
| 3.1 Adjustment of the spring rate..... | 7 |
| 3.2 Adjustment of the spring tension..... | 8 |
| 3.3 Adjustment of the limit stop..... | 9 |
| 4. Others..... | 9 |
| 5. Drawings..... | 10 |
| 6. Product Line..... | 13 |

12" RGA

With Dust Cover

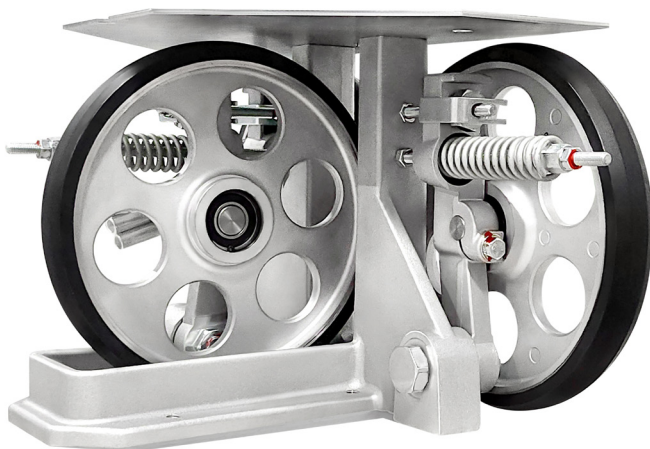

1. General

- The roller guides come pre-adjusted (at the zero level) and sealed from the factory.
- HZ300: The roller guides are able to take unbalanced forces up to 450N. Therefore the rollers must be readjusted on site.
- HZ300XL&XM: 60N for HZ300XL & 120N for HZ300XM
- If readjustment of old roller guides must be done for some other reasons, (for example in case of modernization) the adjustment must be done according section 3.
- Max. speed for use on car.....
10m/s(HZ300)

Guide rails . . . k=16mm n≥34 T89/A,T89/B,T114/B,T90/A,T90/B,T125/B
T127/B,T127-1/B,T127-2/B
K=19mm n≥51 T140-1/B

k=16mm n≥34 T89/A,T89/B,T114/B,T90/A,T90/B,T125/B
T127/B,T127-1/B,T127-2/B
K=19mm n≥51 T140-1/B

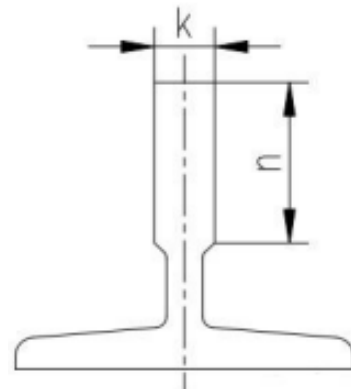

12" RGA

2. Adjustment of the position of the roller guides

- The position adjustment of the roller guides is done as bellow described.

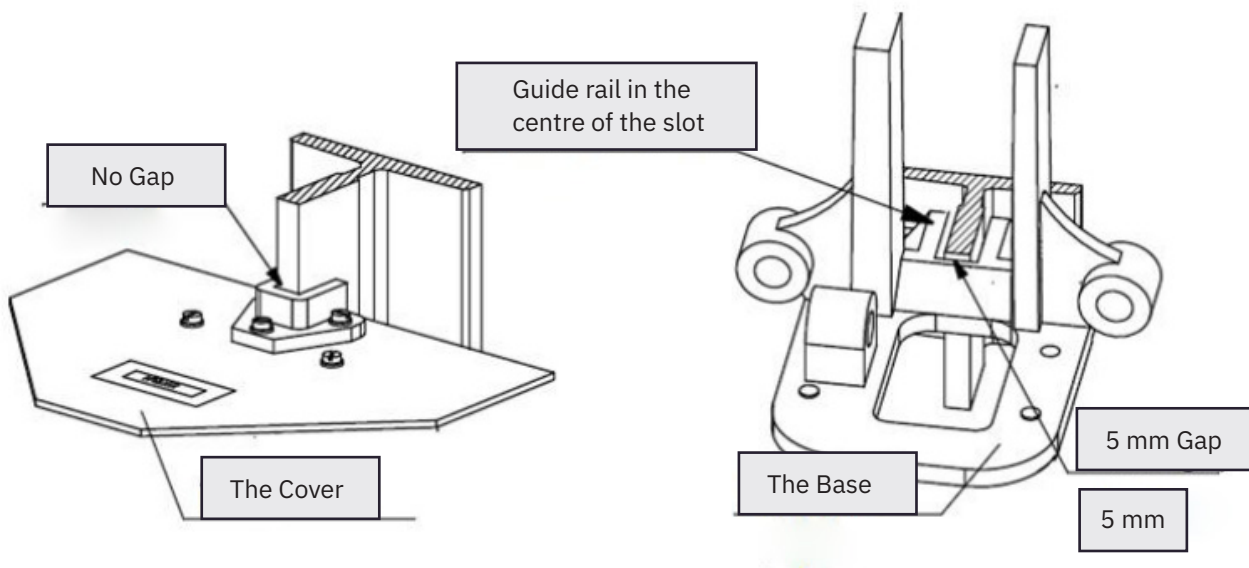

Fig. 2. Checking of the position of the slider and the guide rail

C-08-0820-G19

| | |
|------------------------|--------------------------------|
| Rated Speed | Car - 2000 FPM; CWT - 2000 FPM |
| Rail Width | 0.74" (19mm) |
| Roller Diameter | 12" (300mm) |
| V | 1.14" (29mm) |
| Rated Load | Normal - 120N |
| | Braking - 3500N |
| Roller Hardness | 75 ± 5 |
| Weight | 62.83 LBS (28.5 kg) |
| Car Rated Load | 4400 LBS |
| Delco SKU | C-08-0820-G19 |

12" RGA

- Make sure that the plastic slider firmly touches the guide rail when the car or counterweight is in the correct position.
- At the same time the slot hole of the base should be central to the guide rail and should have the required 5mm gap between the rail and the bottom of the slot.
- If these requirements are not achieved the roller guides are most probably not straight and must be aligned as described in Fig. 3. The required shimming accuracy is 0.5mm
- Align the roller guides in relation to the guide rails so that the requirements shown in figure 2. and 3. are achieved.
- The required shimming accuracy is 0.5mm

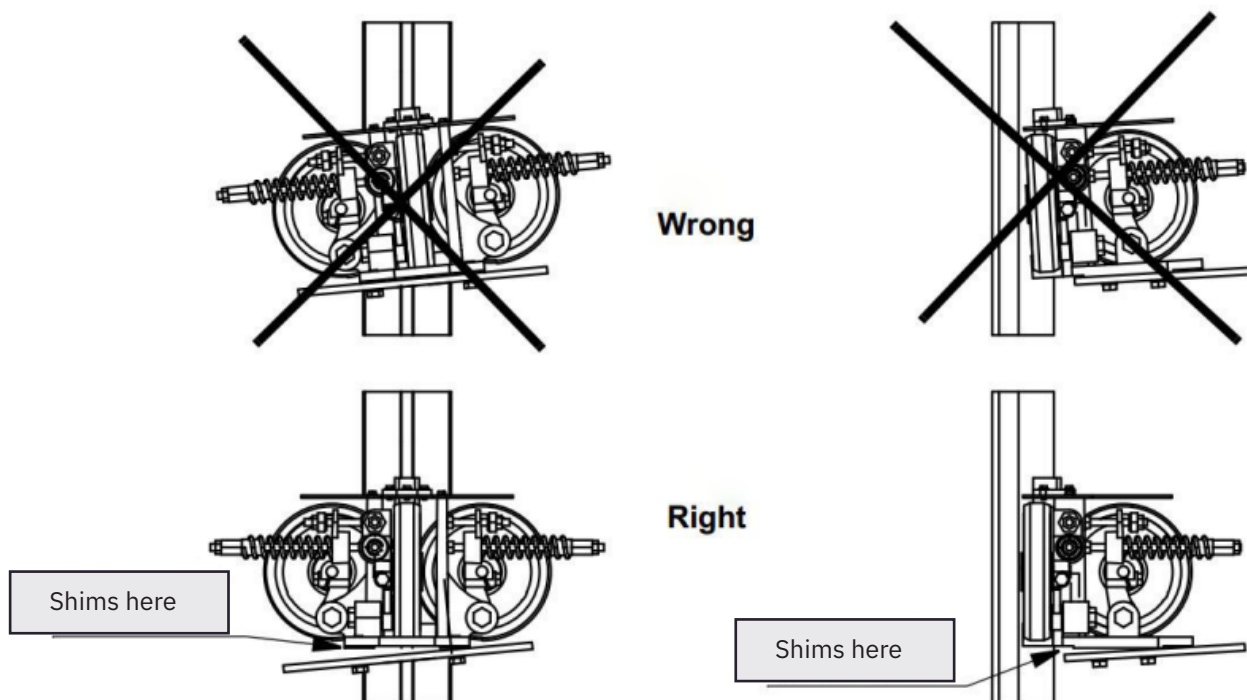

Fig. 3. Alignment of the roller guides

12" RGA

3. Adjustment of the springs and the movement limiters

- Before the adjustment can be done the car must be balanced at the lowest level.
- Make also sure that the roller guides position and alignment is correct (Fig. 2).
- Check the unbalancing forces F_{d1} , F_{d2} & F_{b1}/F_{b2} from installation layout drawings.
- Pick out the appropriate values of additional pre-tension from the table below
- Adjust each roller guide accordingly (see chapters 3.1 & 3.2)
- Check if the cabin is balanced -> make a "fine adjustment" if necessary
- Mark the adjusted values in the label at each roller guide cover.

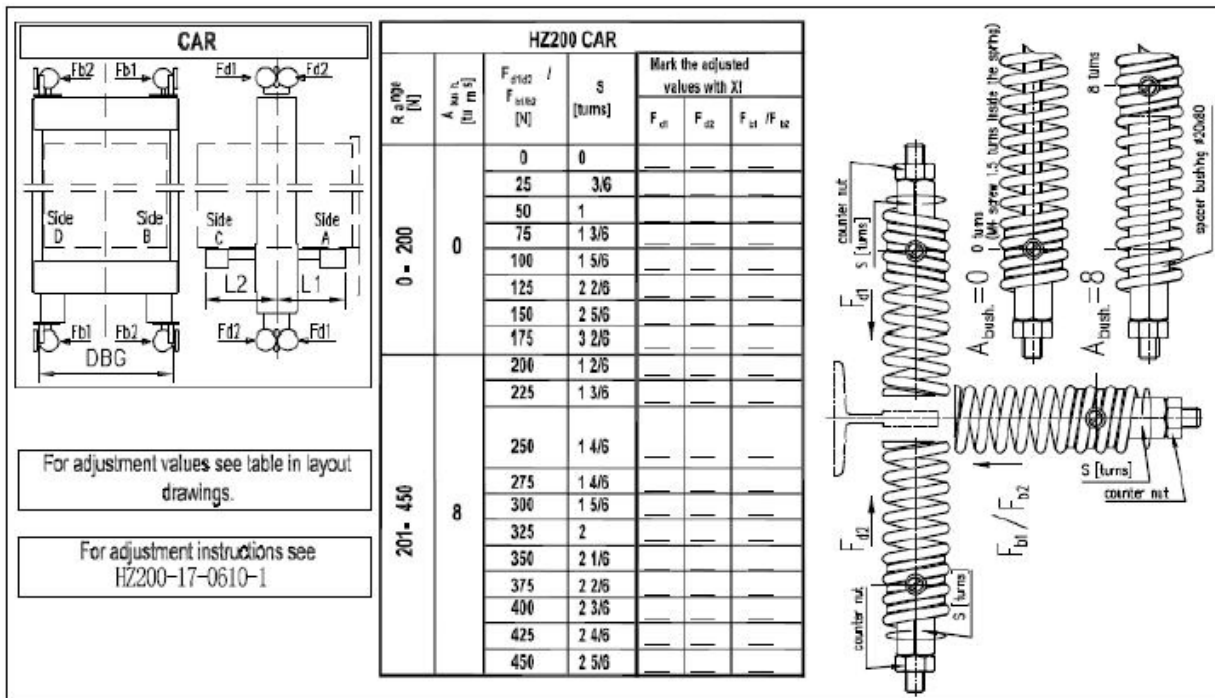

Fig. 4. Spring tension settings for unbalancing forces

12" RGA

3.1 Adjustment of the spring rate

- The spring rate adjustment must be the same for all spring & roller guides on the frame!
 - Loosen the counter nut, the adjustment nut and the screw on the adjusting bushing (see Figure 5).
 - Tight the adjusting bushing right balance value according to information given in layout drawing and label on RG cover (see Fig. 3).
- The adjusting bushing comes pre-adjusted to zero position, this means that the M4 screw is 1.5 turns inside the spring.
 - Secure the adjustment by tightening of the M4 screw.
 - If necessary, add the spacer bushing between the adjusting nut & bushing (to be able to access the adjusting nut by a screw wrench, see Figure 6)

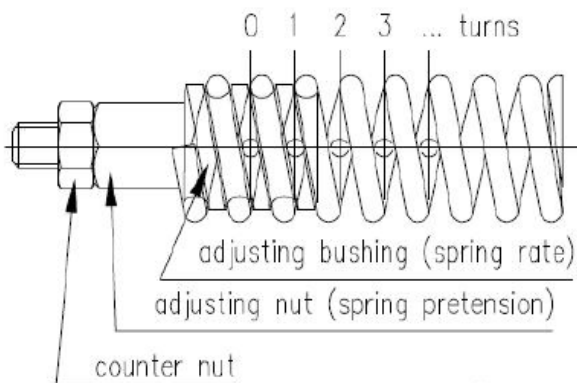

Figure 5. spring pretension adjustment

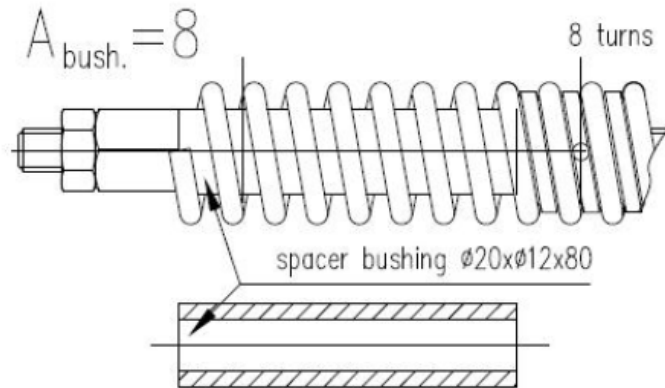

Figure 6. spring rate adjustment

12" RGA

3.2 Adjustment of the spring tension

- The spring tension will be pre-adjusted at the factory.
- The zero tension for all springs equals 3 turns of the adjusting nut.
- To compensate the unbalance, some springs must be readjusted on building site related to the unbalancing of the cabin (see Fig. 3).
- The required forces can be found on the layout drawing.
- Loosen the counter nut.
- If the position of the adjusting bushing has changed:
 1. Loosen the adjusting nut until the spring gets loose.
 2. Check if the adjusting nut is reachable by a screw wrench (because of higher spring rates the nut will disappear behind the spring)

----use spacer bushings if necessary.
 3. Tight the adjusting nut till the clearance is gone.
 4. Tighten the adjusting nut 3 turns.
- Tight the adjusting nut right balance value according to information given in layout drawing and label on cover (see Fig. 3).
- Secure the adjustment by tightening of the counter nut.
- Mark X to the right place in label (at the HZ cover).

12" RGA

3.3 Adjustment of the limit stop

- The movement limiter gap will be pre-adjusted at the factory. For HZ200 the nominal gap is 4 mm (with guide rail in nominal position).
- The limit stop must not be readjusted on site! Because of the restricted running clearance at the safety gear, it is not allowed to adjust higher values than 4 mm.

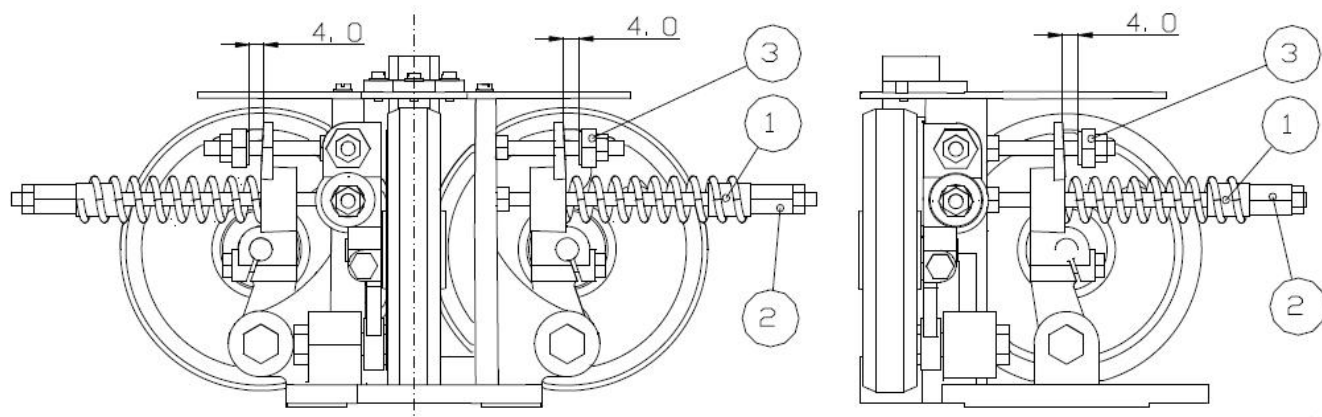
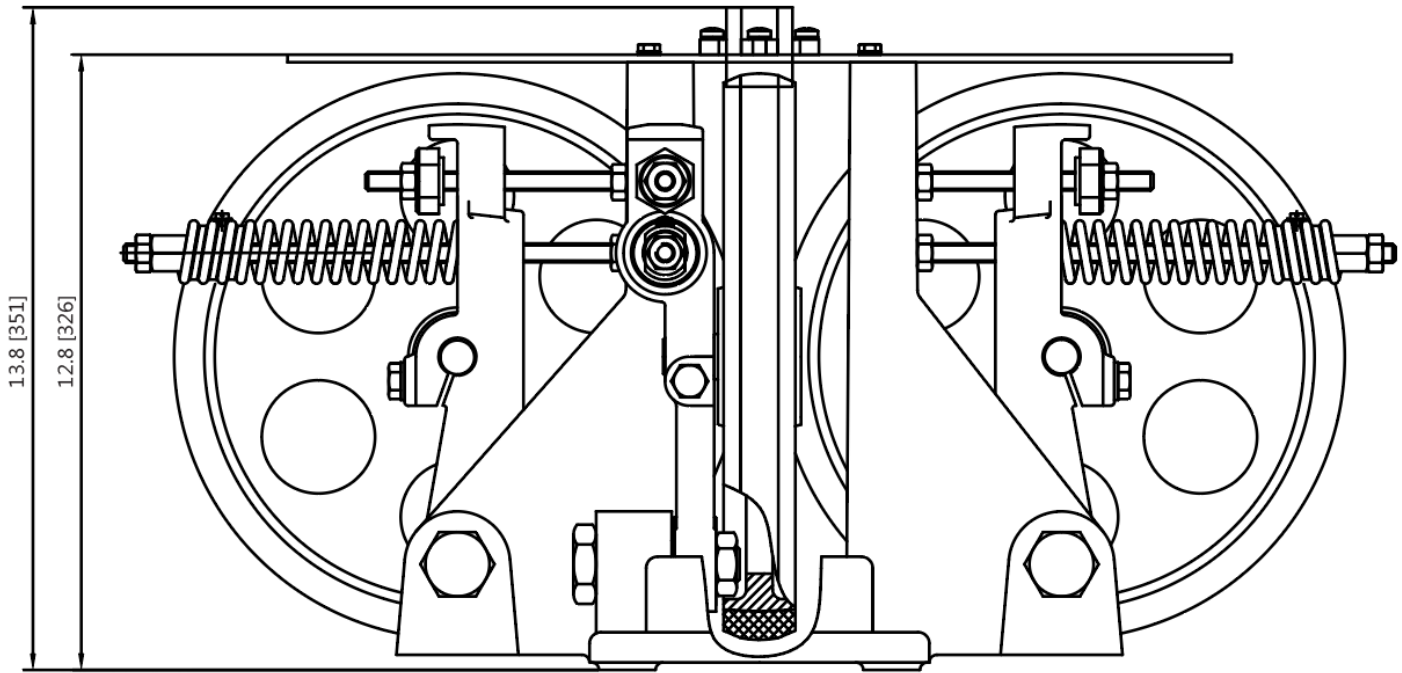

Fig. 7. Adjusting possibilities of HZ200

4. Others

- Drive the car to the mid shaft and carry out the final balancing.
- Drive up and down a few times with service drive speed and check the clearances of the landing door
- Lock roller and other shaft equipment.
- Drive several times up and down with normal speed, stand in various places in the car and observe the lift's performance.

12" RGA



12" RGA

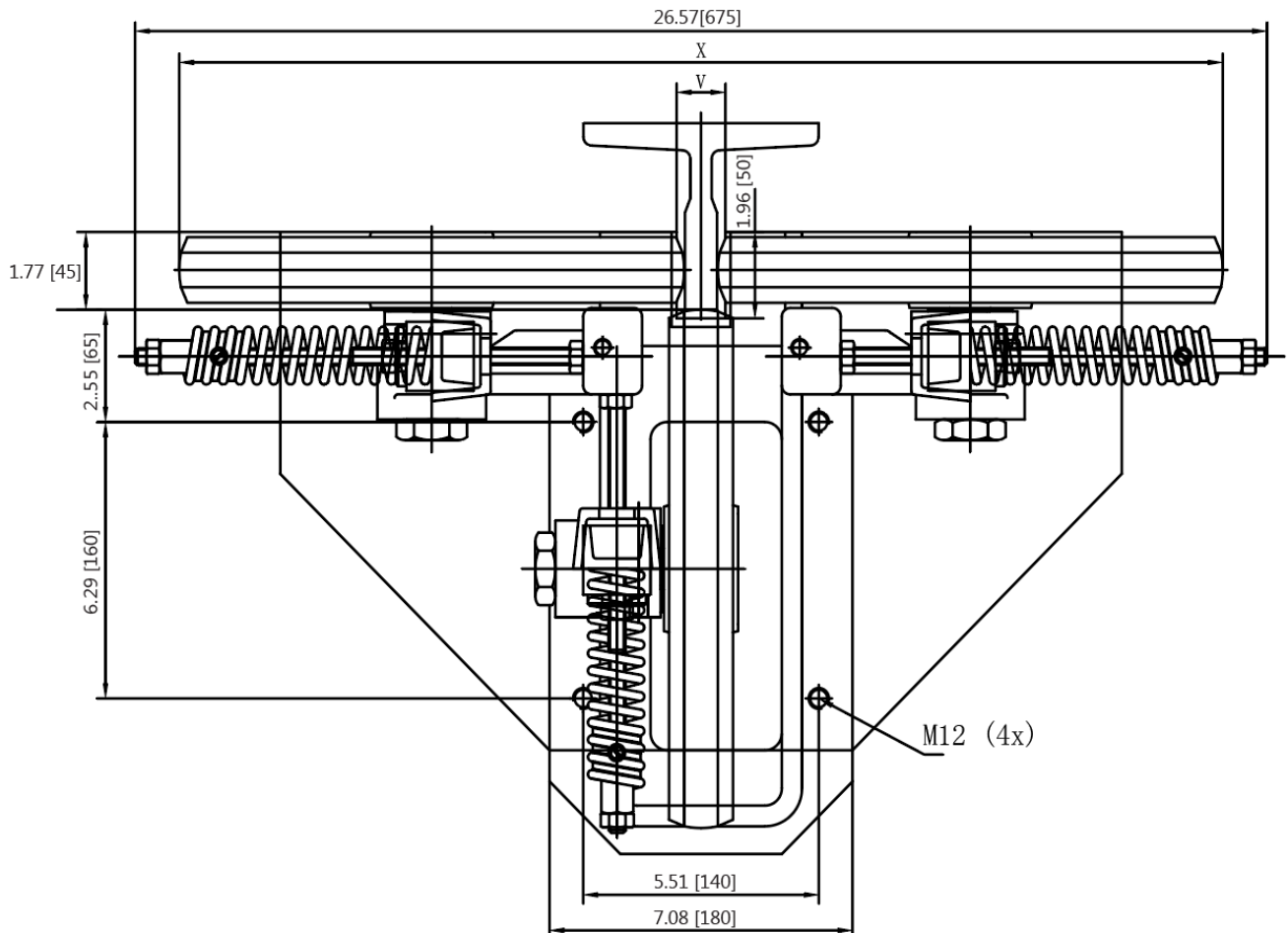

12" RGA

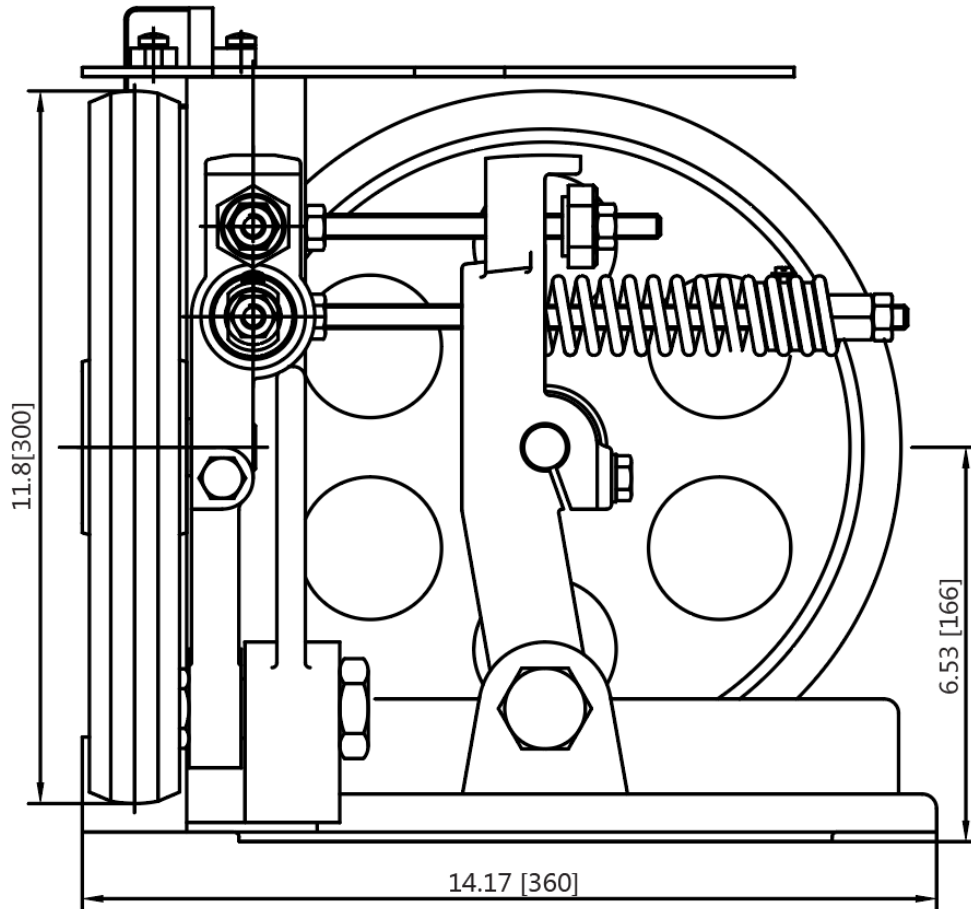

ROLLER GUIDES

9 Models | up to 3000 KG | up to 2000 fpm

Proven

With over 17,000 Delco Roller Guide Assemblies installed and running every day, our products are being relied on by hundreds of elevator contractors.

CAPACITY: 0 – 6615 LBS (3000 KG)

SPEED: 0 – 2000 FPM (6.0M/S)

Meeting the requirements for over 90% of elevator installations, Delco offers 9 different RGA models. Low-rise, mid-rise and high-rise buildings throughout North America use Delco Roller Guides.

Easy to install and easy to maintain, Delco Roller Guides are manufactured with high precision, using the best materials, to provide many years of worry-free operation in many different elevator installation situations.

3" to 10" RGA

0-1200 fpm

Delco's 3" to 10" rollers are made from Polyurethane, which has a high compression strength and doesn't create flat spots, ensuring reliable operation for many years. The cast iron frames and heavy duty hardware ensure a long life in all elevator hoistway environments. These roller guides are made with NSK ball bearings manufactured in Japan, recognized world wide as the most reliable, high performance bearings.

12" RGA

Up to 2000 fpm

Delco's 12" rollers are made from vulcanized rubber for resilience and durability. The 12" RGA frame is constructed from high-intensity aluminum alloy providing robust structural support for stability and long-lasting performance. Delco's 12" RGA utilizes high performance, brand CW: type 6205, ball bearings.

Product Line

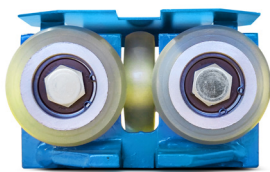

3" SPRING FREE
C-08-0815 (16 mm)
C-08-0817 (10 mm)

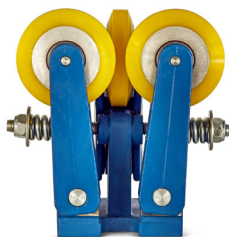

3 1/4" STANDARD
C-08-0810

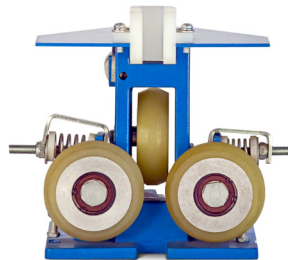

3 1/4" HIGH SPEED
C-08-0807

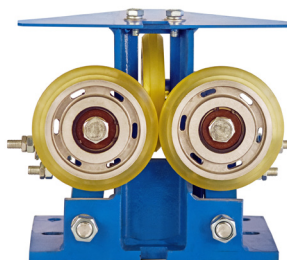

5" STANDARD
C-08-0805

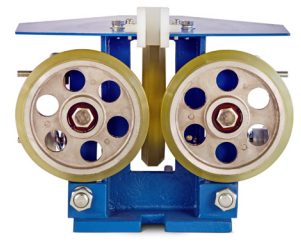

6" STANDARD
C-08-0804

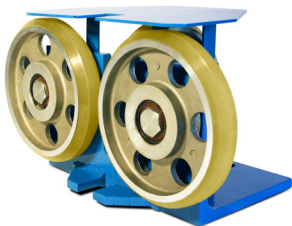

6" SPRING FREE
C-08-0806

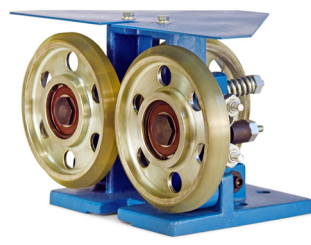

7 7/8" STANDARD
C-08-0808

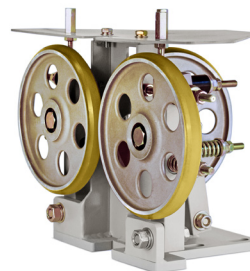

10" HIGH SPEED
C-08-0803



12" HIGH SPEED
C-08-0820-G19

SELECTION GUIDE

| Passenger Elevator | 0-500fpm (0-2.5m/s) | | 600-800fpm (3.0-4.0m/s) | | 1000-1200fpm (5.0-6.0m/s) | |
|-----------------------|------------------------|-------------------------------------|----------------------------|-----------|------------------------------|-----------|
| | Delco Car | Delco CWT | Delco Car | Delco CWT | Delco Car | Delco CWT |
| <3000lbs (<1350kg) | C-08-0805 C-08-0804 | C-08-0810 C-08-0807 C-08-0815 | C-08-0804 | C-08-0807 | C-08-0803 | N/A |
| 3500lbs (1600kg) | C-08-0805 C-08-0804 | C-08-0810 C-08-0807 C-08-0815 | C-08-0804 | C-08-0807 | C-08-0803 | N/A |
| 4000lbs (1800kg) | C-08-0804 | C-08-0810 C-08-0807 C-08-0806 | C-08-0804 | C-08-0807 | C-08-0803 | N/A |
| 4500lbs (2050kg) | C-08-0808 | C-08-0806 | C-08-0808 | C-08-0806 | C-08-0803 | N/A |
| 5000lbs (2300kg) | C-08-0808 | C-08-0806 | C-08-0808 | C-08-0806 | C-08-0803 | N/A |
| 6000lbs (2700kg) | C-08-0808 | C-08-0806 | C-08-0808 | C-08-0806 | C-08-0803 | N/A |
| 7000lbs (3200kg) | C-08-0803 | C-08-0806 | C-08-0803 | C-08-0806 | N/A | N/A |

| Hospital Elevator | 0-250fpm (0-1.25m/s) | | 300-500fpm (1.5-2.5m/s) | | 600-800fpm (3.0-4.0m/s) | | 1000-1200fpm (5.0-6.0m/s) | | 1000-2000fpm (5.0-10m/s) | |
|-----------------------|-------------------------|-------------------------------------|----------------------------|-------------------------------------|----------------------------|------------------------|------------------------------|-----|-----------------------------|-----|
| | Car | CWT | Car | CWT | Car | CWT | Car | | Car | CWT |
| <3000lbs (<1350kg) | C-08-0805 C-08-0804 | C-08-0810 C-08-0807 C-08-0815 | C-08-0805 C-08-0804 | C-08-0810 C-08-0807 C-08-0815 | C-08-0804 | C-08-0807 C-08-0815 | C-08-0803 | N/A | C-08-0820-G19 | N/A |
| 3500lbs (1600kg) | C-08-0805 C-08-0804 | C-08-0810 C-08-0807 C-08-0815 | C-08-0805 C-08-0804 | C-08-0810 C-08-0807 C-08-0815 | C-08-0804 | C-08-0807 | C-08-0803 | N/A | C-08-0820-G19 | N/A |
| 4000lbs (1800kg) | C-08-0804 | C-08-0806 | C-08-0804 | C-08-0806 | C-08-0804 | C-08-0807 | C-08-0803 | N/A | C-08-0820-G19 | N/A |
| 4500lbs (2050kg) | C-08-0808 | C-08-0806 | C-08-0808 | C-08-0806 | C-08-0808 | C-08-0806 | N/A | N/A | N/A | N/A |
| 5000lbs (2300kg) | C-08-0808 | C-08-0806 | C-08-0808 | C-08-0806 | C-08-0808 | C-08-0806 | N/A | N/A | N/A | N/A |
| 6000lbs (2700kg) | C-08-0808 | C-08-0806 | C-08-0808 | C-08-0806 | C-08-0808 | C-08-0806 | N/A | N/A | N/A | N/A |
| 7000lbs (3200kg) | C-08-0803 | C-08-0806 | C-08-0803 | C-08-0806 | C-08-0803 | C-08-0806 | N/A | N/A | N/A | N/A |

Freight Elevator

For freight elevator applications the Roller Guide Assembly selection will be based on the number of guide rails. For applications with 2 guide rails, refer to the Passenger Elevator chart above. For applications with 4 or more guide rails, please contact us.

Important!

Please note that this table is only to be used as a guideline. Roller Guide Assembly selection must take many other criteria into consideration that can't be accounted for in this chart. Please contact us for selection assistance.