

**DELCO**  
ELEVATOR PRODUCTS



**HAIDERDRIVE**

The Ultimate Combination of Quality and Affordability

# Traction Elevator Machines



[www.delcoelevator.com](http://www.delcoelevator.com)

[info@delcoelevator.com](mailto:info@delcoelevator.com) | 1.866.900.3727

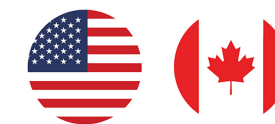

# CONTENTS

WELCOME .....	3
About Delco .....	3
Product Line .....	4
About Haider Drive .....	5
OVERHEAD GEARED MACHINE .....	6
HGD200 - SB .....	8
HGD245 .....	9
HGD245 - SB .....	10
HGD245D .....	11
HGD245D - SB .....	12
HGD320 - 27.6 .....	14
HGD320 - 31.5 .....	15
HGD320A - SC .....	16
HGD320A - SC - V45 .....	17
HGD410 - 32.3 .....	18
HGD410 - 35.8 .....	19
BASEMENT MACHINE .....	20
HGD1B .....	22
HGD1B - SC .....	23
HGD320B - 27.6 .....	24
HGD320B - 31.5 .....	25
HGD320B - SC .....	26
HGL292AB - V45 .....	27
HGL292AB .....	28
MACHINE ROOMLESS .....	30
HGL205F .....	32
HGL205G .....	33
HGL280 .....	34
HGL290 - V45 .....	35
HGL332 - 8mm .....	36
HGL332 - 10 mm .....	37
HGL333 .....	38
HGL334 .....	39
ECO GEARLESS .....	40
HGL292 - V45 .....	42
HGL292A .....	43
HGL292A - V45 .....	44
HGL320 - V45 .....	45
PRO GEARLESS .....	46
HGL401 .....	48
HGL402 - 1 .....	49
HGL402 - 2 .....	50
HGL402A .....	52
HGL403 - 1 .....	53
HGL403 - 2 .....	54
HGL403A .....	55

## In Stock, Non-Proprietary, Proven & Competitive

Delco Elevator Products Ltd. has always been a family owned and operated business and is proud to have been helping our customers with elevator components for over 45 years.

With a head office and warehouse in Vancouver, BC, Canada, and a warehouse in Seattle, WA, USA, Delco is strategically located to source, stock and ship elevator products to customers in Canada, the Caribbean and the US.

From MRL packages & machines to popular components, including roller guides, shackles, oil buffers, governors and door edges to a range of elevator parts, the company's comprehensive product selection is one of the reasons that customers have been returning to Delco for decades.

Another reason is that we are very good at ensuring that the right items arrive at the right time to elevator contractors across North America.

Delco's dedicated, experienced and enthusiastic team works diligently to provide exceptional service in the following key areas:

- **In Stock:** We keep our components stocked to make sure that customers receive what they need, when they need it.
- **Non-Proprietary:** Delco's products are universal – perfect for modernizations.
- **Proven Products:** Delco manufactures and distributes products that are tried, tested and proven in the field.
- **Compliant:** Delco products and equipment meet all elevator industry compliance and certification standards.
- **Value for Money:** In a highly competitive marketplace, Delco provides the best quality elevator equipment at the lowest possible prices.
- **Personal, Knowledgeable Staff and Service:** Always on hand to assist you with your unique requirements!

## HOW TO ORDER

Delco services elevator contractors and OEMs in Canada, the Caribbean and the US, including Puerto Rico and Hawaii.

Phone: 1.604.904.3727 - CAN/USA  
Toll Free: 1.866.900.3727  
Email: [info@delcoelevator.com](mailto:info@delcoelevator.com)  
[www.delcoelevator.com](http://www.delcoelevator.com)

We'd love to hear from you and give you a quote on your next project. **Call, email or visit us today!**

We look forward to welcoming you to our family of customers and friends.

OFFICE & WAREHOUSE CANADA  
#205-3765 1st Avenue  
Burnaby, BC V5C 3V8

WAREHOUSE USA  
2302 West Valley Highway North, Suite 300, Auburn,  
WA 98001

# PRODUCT LINE

In Stock, Non-Proprietary, Proven & Competitive

**Product Line:**

- Haider Drive Elevator Machines
- New Construction Packages
- MOD Packages
- Governors
- Roller Guide Assemblies
- Oleo Oil Buffers
- Shackles
- Safety Barricades
- Cartop and Run Stations
- Limit Switches
- WECO Door Detectors
- Door Closers
- Boards, Parts and Tools

Most Popular:

**D.MRL**  
P A C K A G E

**MOD**  
P A C K A G E

# NEW CONSTRUCTION PACKAGES

Machine Roomless	Machine Room	Hydraulic
------------------	--------------	-----------

# HAIDERDRIVE

Introducing  
The Ultimate Combination Of  
Quality & Affordability

HAIDER DRIVE is a full line of **CSA approved** elevator machines for modernization & new construction

**About Haider Drive:**

Haider Drive Co., Ltd is an advanced technology manufacturing company.

The company's primary focus lies in the design and manufacture of both geared and gearless elevator traction machines, catering to a broad range of load capacities of up to 12,000 lbs and speeds of up to 1,400 FPM.

The Haider Drive traction machines have received both the CE certification for compliance with European standards, as well as the CSA certification for the North American market.

Since its inception in 2021, the company has established robust partnerships with distributors and customers across China, Africa, and Southeast Asia. Annually, Haider Drive Co., Ltd serves over 500 clients domestically and internationally.

In pursuit of accelerated future growth, Haider Drive Co., Ltd is dedicated to further cultivating its presence in the international market, with a particular focus on North America.

Geared	Basement	MRL	ECO Gearless	PRO Gearless
--------	----------	-----	--------------	--------------

CSA Approved

High Quality

Full Line

Best Price

# OVERHEAD GEARED

# OVERHEAD GEARED

## Benefits:

- Large start torque
- Large sheave diameter
- Either 1/2" or 5/8" rope
- Emergency Brake as Option
- Easy maintenance
- Simple brake adjustments
- Flange mount motors dismount easily and simplify
- Bronze gear
- With Incremental encoder

## Standard Features:

- Accurate Motor Control with VVVF design
- Gearbox with asynchronous motor
- Flexibly useable, both in modernisation and in new installations
- Drive sheave rope retainer
- Either Left or Right hand
- Roping 1:1
- Capacity up to 12000 lbs
- Speed up to 500 fpm
- Temperature monitoring by PTC thermistor

## HGD Series

HAIDERDRIVE

Roping 1:1	Speed (FPM)									
	50	100	150	200	250	300	350	400	450	500
1500	HGD200							HGD245	HGD245D	
1760										
2000	HGD245									
2500										
3000	HGD245D								HGD320	
3500										
4000	HGD320A									
4500										
5000										
5500										
6000	HGD320									
7000	HGD320				HGD410					
8000	HGD410									
9000										
10000	HGD410									
12000	HGD410									

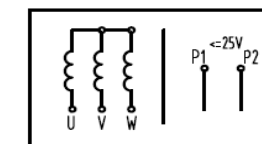

Power Wiring Diagram

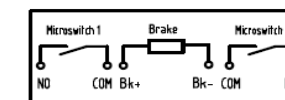

Brake Wiring Diagram

# OVERHEAD GEARED



## HGD200-SB



Traction Machine	
Roping	1:1
Max Shaft Load (lbs)	9900
Weight(lbs)	1450
Sheave	5 Grooves *1/2"(U30~96.5°) *3/4" Pitch
Normal Brake	
Model	DRB-9E
Pick/Hold Voltage (VDC)	110/67
Pick/Hold Current (A)	1.1/0.67
Emergency Brake	
Model	DRB-20E
Pick/Hold Voltage (VDC)	110/60
Pick/Hold Current (A)	2.75/1.35

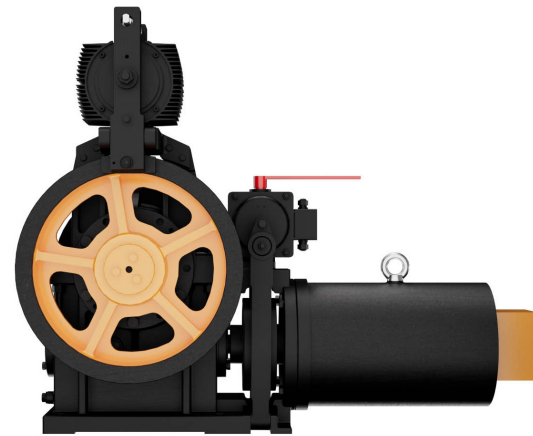

Machine Part No.	Rated Load (lbs)	Speed (fpm)	Ratio	Sheave Diameter (in)	Power (HP)	Pole	Rated Speed (Rpm)	Voltage (VAC)	Rated Frequency (Hz)	Rated Current (A)
HGD200-1715-DV-L-SB-1/2	1760	150	41:1	20.9	10	6	1170	460/208	60	13.5/29
HGD200-1720-DV-L-SB-1/2	1760	200	41:1	20.9	12	4	1770	460/208	60	14.5/32
HGD200-1735-DV-L-SB-1/2	1760	350	47:2	20.9	20	4	1770	460/208	60	24/51.5

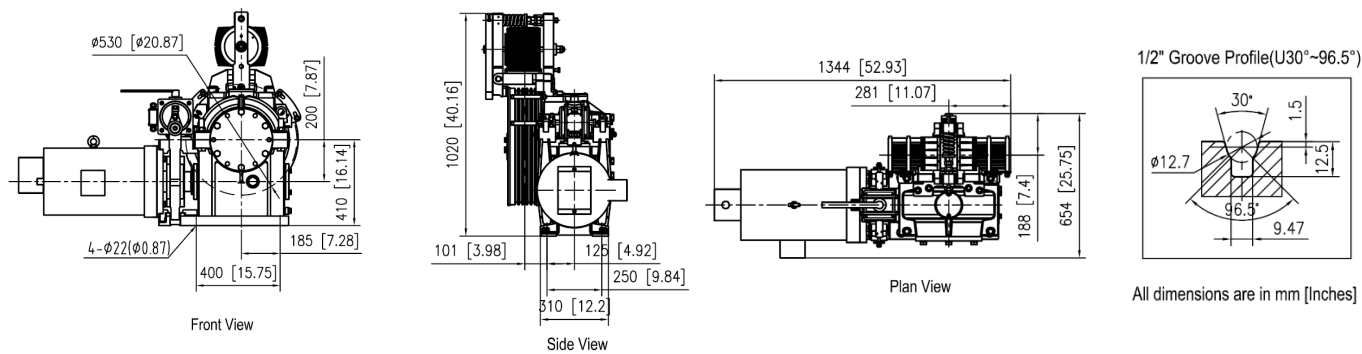

### Notes

- 1.You can choose either right hand or left hand.
- 2.Sheave brake is optional.

# OVERHEAD GEARED



## HGD245



Traction Machine	
Roping	1:1
Max Shaft Load (lbs)	16500
Weight(lbs)	1900
Sheave	6 Grooves *1/2"(U30~96.5°) *3/4" Pitch
Sheave	5 Grooves *5/8"(U30~96.5°) *1" Pitch
Normal Brake	
Model	DRB-12E
Pick/Hold Voltage (VDC)	110/65
Pick/Hold Current (A)	2.0/1.18
Emergency Brake	
N/A	

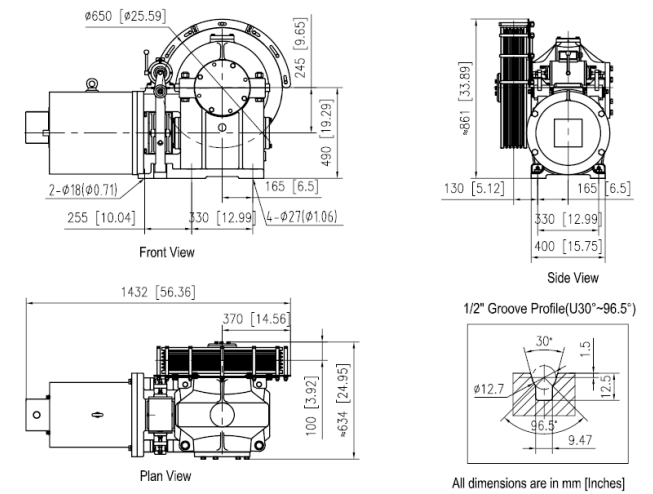

Machine Part No.	Rated Load (lbs)	Speed (fpm)	Ratio	Sheave Diameter (in)	Power (HP)	Pole	Rated Speed (Rpm)	Voltage (VAC)	Rated Frequency (Hz)	Rated Current (A)
HGD245-2020-HV-L	2000	200	50:1	25.6	15	4	1770	480	60	17
HGD245-2020-LV-L	2000	200	50:1	25.6	15	4	1770	208	60	39
HGD245-2510-HV-L	2500	100	61:1	25.6	10	6	1170	480	60	14
HGD245-2510-LV-L	2500	100	61:1	25.6	10	6	1170	208	60	32
HGD245-2520-HV-L	2500	200	50:1	25.6	20	4	1775	480	60	23
HGD245-2520-LV-L	2500	200	50:1	25.6	20	4	1775	208	60	53
HGD245-2520-DV-L	2500	200	50:1	25.6	20	4	1775	460/208	60	23/53
HGD245-2535-HV-L	2500	350	61:2	25.6	25	4	1770	480	60	28
HGD245-2535-LV-L	2500	350	61:2	25.6	25	4	1770	208	60	64
HGD245-2535-DV-L	2500	350	61:2	25.6	25	4	1770	460/208	60	28/64
HGD245-2540-HV-L	2500	400	55:2	25.6	30	4	1775	480	60	33
HGD245-2540-LV-L	2500	400	55:2	25.6	30	4	1775	208	60	75

### Notes

- 1.You can choose either right sheave or left sheave.
- 2.You can choose either 1/2" rope or either 5/8" rope.

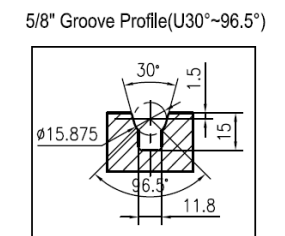

# OVERHEAD GEARED



## HGD245-SB

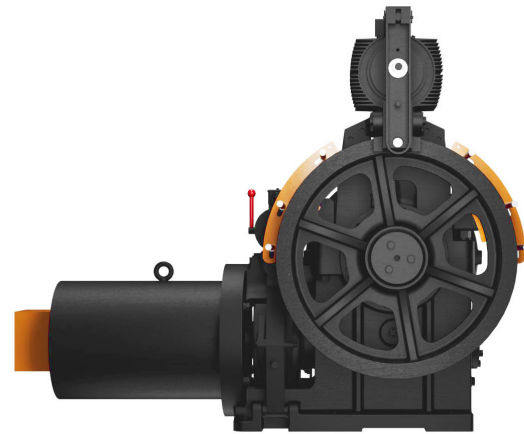

Traction Machine	
Roping	1:1
Max Shaft Load (lbs)	16500
Weight(lbs)	2090
Sheave	6 Grooves *1/2"(U30~96.5°) *3/4" Pitch
Sheave	5 Grooves *5/8"(U30~96.5°) *1" Pitch
Normal Brake	
Model	DRB-12E
Pick/Hold Voltage (VDC)	110/65
Pick/Hold Current (A)	2.0/1.18
Emergency Brake	
Model	DRB-20E
Pick/Hold Voltage (VDC)	110/60
Pick/Hold Current (A)	2.75/1.35

Machine Part No.	Rated Load (lbs)	Speed (fpm)	Ratio	Sheave Diameter (in)	Power (HP)	Pole	Rated Speed (Rpm)	Voltage (VAC)	Rated Frequency (Hz)	Rated Current (A)
HGD245-2020-HV-L-SB	2000	200	50:1	25.6	15	4	1770	480	60	17
HGD245-2020-LV-L-SB	2000	200	50:1	25.6	15	4	1770	208	60	39
HGD245-2510-HV-L-SB	2500	100	61:1	25.6	10	6	1170	480	60	14
HGD245-2510-LV-L-SB	2500	100	61:1	25.6	10	6	1170	208	60	32
HGD245-2520-HV-L-SB	2500	200	50:1	25.6	20	4	1775	480	60	23
HGD245-2520-LV-L-SB	2500	200	50:1	25.6	20	4	1775	208	60	53
HGD245-2520-DV-L-SB	2500	200	50:1	25.6	20	4	1775	460/208	60	23/53
HGD245-2535-HV-L-SB	2500	350	61:2	25.6	25	4	1770	480	60	28
HGD245-2535-LV-L-SB	2500	350	61:2	25.6	25	4	1770	208	60	64
HGD245-2535-DV-L-SB	2500	350	61:2	25.6	25	4	1770	460/208	60	28/64
HGD245-2540-HV-L-SB	2500	400	55:2	25.6	30	4	1775	480	60	33
HGD245-2540-LV-L-SB	2500	400	55:2	25.6	30	4	1775	208	60	75

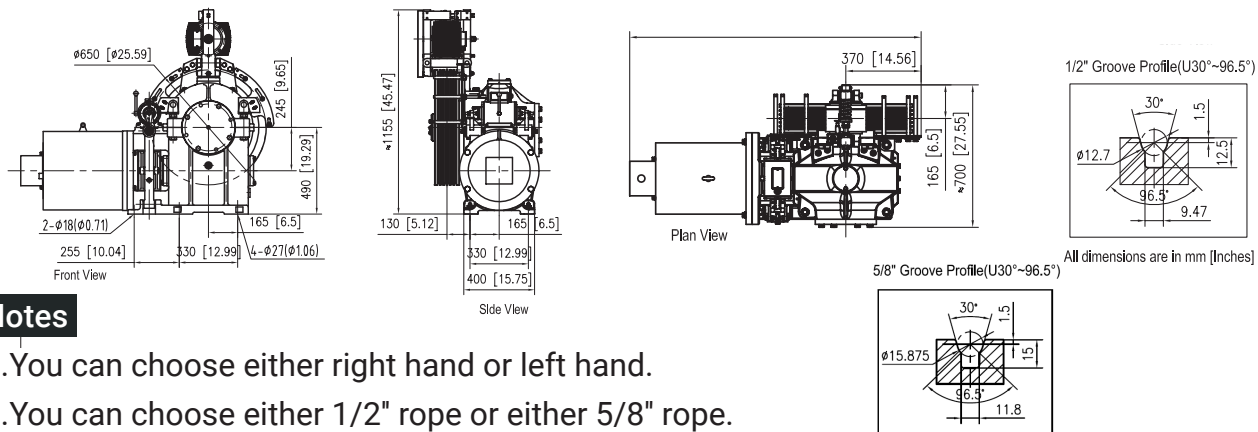

### Notes

1. You can choose either right hand or left hand.
2. You can choose either 1/2" rope or either 5/8" rope.

# OVERHEAD GEARED



## HGD245D



Traction Machine	
Roping	1:1
Max Shaft Load (lbs)	24200
Weight(lbs)	2050
Sheave	8 Grooves *1/2"(U30~96.5°) *3/4" Pitch
Sheave	6 Grooves *5/8"(U30~96.5°) *1" Pitch
Normal Brake	
Model	DRB-12E
Pick/Hold Voltage (VDC)	110/65
Pick/Hold Current (A)	2.0/1.18
Emergency Brake	
N/A	

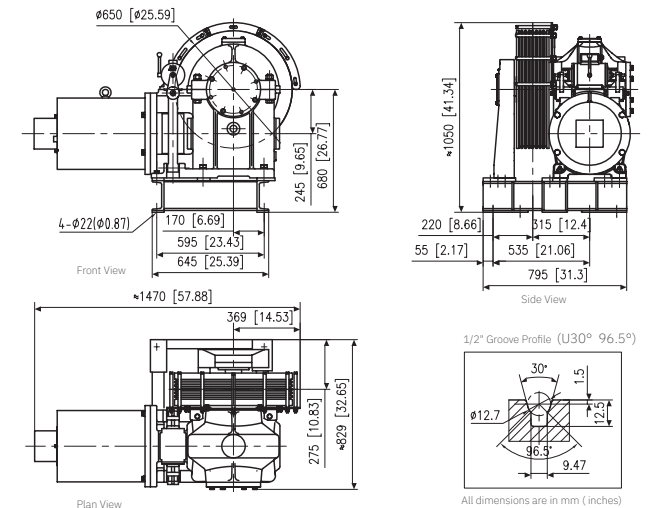

Machine Part No.	Rated Load (lbs)	Speed (fpm)	Ratio	Sheave Diameter (in)	Power (HP)	Pole	Rated Speed (Rpm)	Voltage (VAC)	Rated Frequency (Hz)	Rated Current (A)
HGD245D-2545-HV-L	2500	450	49:2	25.6	35	4	1770	480	60	40
HGD245D-2545-DV-L	2500	450	49:2	25.6	35	4	1770	460/208	60	40/87.5
HGD245D-2550-HV-L	2500	500	70:3	25.6	35	4	1770	480	60	40
HGD245D-2550-DV-L	2500	500	70:3	25.6	35	4	1770	460/208	60	40/87.5
HGD245D-3520-HV-L	3500	200	50:1	25.6	25	4	1770	480	60	28
HGD245D-3520-LV-L	3500	200	50:1	25.6	25	4	1770	208	60	64
HGD245D-3520-DV-L	3500	200	50:1	25.6	25	4	1770	460/208	60	28.5/62.5
HGD245D-3535-HV-L	3500	350	61:2	25.6	35	4	1770	480	60	40
HGD245D-3535-DV-L	3500	350	61:2	25.6	35	4	1770	460/208	60	40/87.5
HGD245D-3540-HV-L	3500	400	55:2	25.6	40	4	1770	480	60	45

### Notes

1. You can choose either right hand or left hand.
2. You can choose either 1/2" rope or either 5/8" rope.

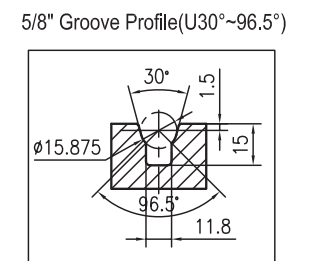

## HGD245D-SB



Traction Machine	
Roping	1:1
Max Shaft Load (lbs)	24200
Weight(lbs)	2610
Sheave	8 Grooves *1/2"(U30~96.5°) *3/4" Pitch
Sheave	6 Grooves *5/8"(U30~96.5°) *1" Pitch
Normal Brake	
Model	DRB-12E
Pick/Hold Voltage (VDC)	110/65
Pick/Hold Current (A)	2.0/1.18
Emergency Brake	
Model	DRB-21E
Pick/Hold Voltage (VDC)	110/65
Pick/Hold Current (A)	3.6/1.7

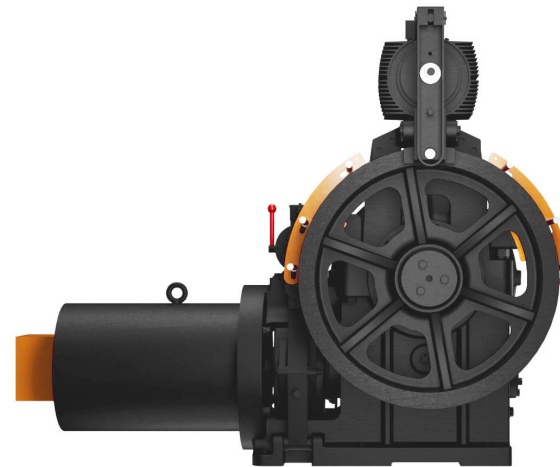

Machine Part No.	Rated Load (lbs)	Speed (fpm)	Ratio	Sheave Diameter (in)	Power (HP)	Pole	Rated Speed (Rpm)	Voltage (VAC)	Rated Frequency (Hz)	Rated Current (A)
HGD245D-2545-HV-L-SB	2500	450	49:2	25.6	35	4	1770	480	60	40
HGD245D-2545-DV-L-SB	2500	450	49:2	25.6	35	4	1770	460/208	60	40/87.5
HGD245D-2550-HV-L-SB	2500	500	70:3	25.6	35	4	1770	480	60	40
HGD245D-2550-DV-L-SB	2500	500	70:3	25.6	35	4	1770	460/208	60	40/87.5
HGD245D-3520-HV-L-SB	3500	200	50:1	25.6	25	4	1770	480	60	28
HGD245D-3520-LV-L-SB	3500	200	50:1	25.6	25	4	1770	208	60	64
HGD245D-3520-DV-L-SB	3500	200	50:1	25.6	25	4	1770	460/208	60	28.5/62.5
HGD245D-3535-HV-L-SB	3500	350	61:2	25.6	35	4	1770	480	60	40
HGD245D-3535-DV-L-SB	3500	350	61:2	25.6	35	4	1770	460/208	60	40/87.5
HGD245D-3540-HV-L-SB	3500	400	55:2	25.6	40	4	1770	480	60	45

## HGD245D-SB

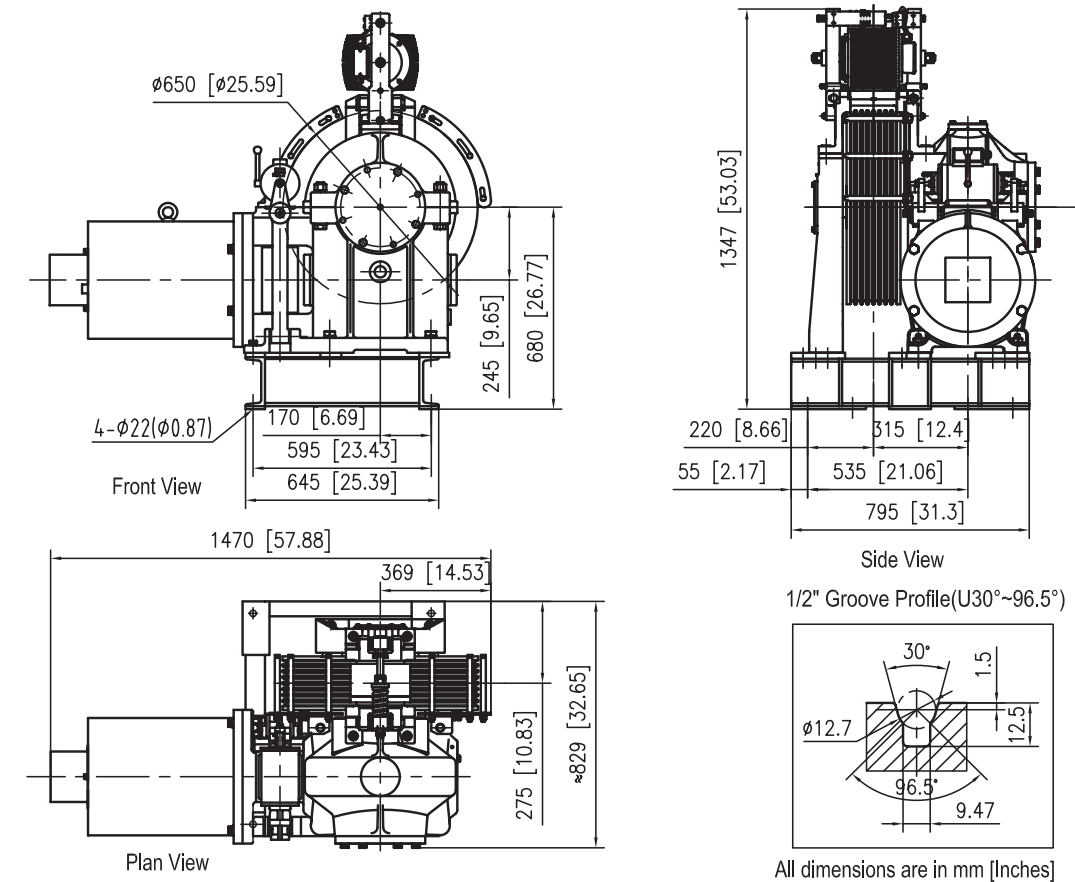

### Notes

1. You can choose either right hand or left hand.
2. You can choose either 1/2" rope or either 5/8" rope.

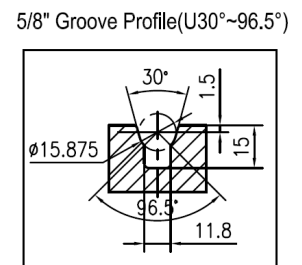

# OVERHEAD GEARED



## HGD320-27.6



Traction Machine	
Roping	1:1
Max Shaft Load (lbs)	31900
Weight(lbs)	3200
Sheave	8 Grooves *5/8"(U30~96.5°) *1" Pitch
Normal Brake	
Model	DRB-13E
Pick/Hold Voltage (VDC)	200/118
Pick/Hold Current (A)	4.0/2.36
Emergency Brake	
N/A	



Machine Part No.	Rated Load (lbs)	Speed (fpm)	Ratio	Sheave Diameter (in)	Power (HP)	Pole	Rated Speed (Rpm)	Voltage (VAC)	Rated Frequency (Hz)	Rated Current (A)
HGD320-6020-HV-L	6000/6500	200	61:1	27.6	40	4	1770	480	60	45
HGD320-6035-HV-L	6000/6500	350	69:2	27.6	60	4	1770	480	60	66
HGD320-7020-HV-L	7000	200	61:1	27.6	50	4	1770	480	60	55

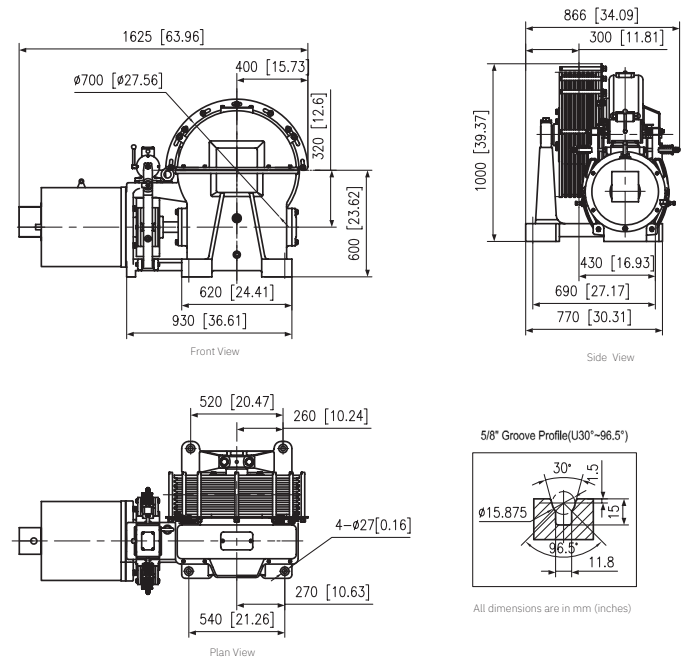

### Notes

You can choose either right hand or left hand.

# OVERHEAD GEARED



## HGD320-31.5



Traction Machine	
Roping	1:1
Max Shaft Load (lbs)	31900
Weight(lbs)	3200
Sheave	8 Grooves *5/8"(U30~96.5°) *1" Pitch
Normal Brake	
Model	DRB-13E
Pick/Hold Voltage (VDC)	200/118
Pick/Hold Current (A)	4.0/2.36
Emergency Brake	
N/A	



Machine Part No.	Rated Load (lbs)	Speed (fpm)	Ratio	Sheave Diameter (in)	Power (HP)	Pole	Rated Speed (Rpm)	Voltage (VAC)	Rated Frequency (Hz)	Rated Current (A)
HGD320-3550-HV-L	3500	500	82:3	31.5	50	4	1770	480	60	55
HGD320-6045-HV-L	6000	450	61:2	31.5	60	4	1770	480	60	66

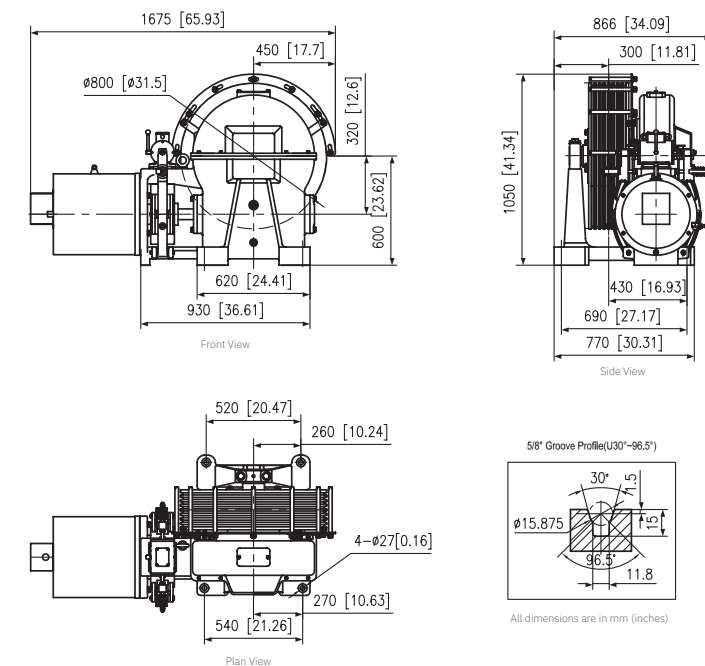

### Notes

You can choose either right hand or left hand.





## HGD320A-SC

Traction Machine	
Roping	1:1
Max Shaft Load (lbs)	27500
Weight(lbs)	3200
Sheave	8 Grooves *5/8"(U30~96.5°) *1" Pitch
Normal Brake	
Model	DRB-13E
Pick/Hold Voltage (VDC)	200/118
Pick/Hold Current (A)	4.0/2.36
Emergency Brake	
Model	JSB35
Pick/Hold Voltage (VDC)	220
Pick/Hold Current (A)	0.24/0.12

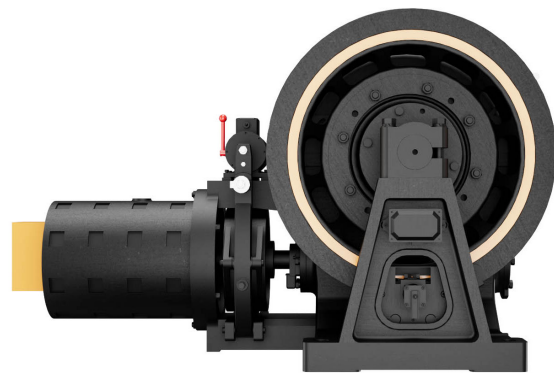

Machine Part No.	Rated Load (lbs)	Speed (fpm)	Ratio	Sheave Diameter (in)	Power (HP)	Pole	Rated Speed (Rpm)	Voltage (VAC)	Rated Frequency (Hz)	Rated Current (A)
HGD320A-5020-L-SC	5000	200	61:1	27.6	35	4	1770	480	60	40
HGD320A-5520-L-SC	5500	200	61:1	27.6	35	4	1770	480	60	40

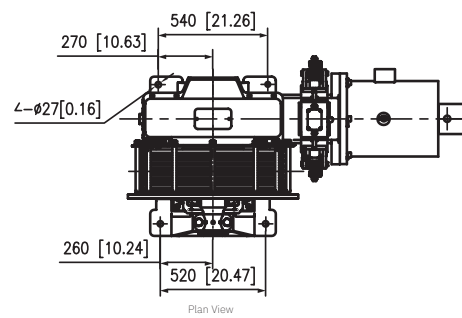
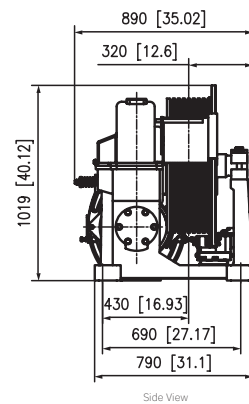
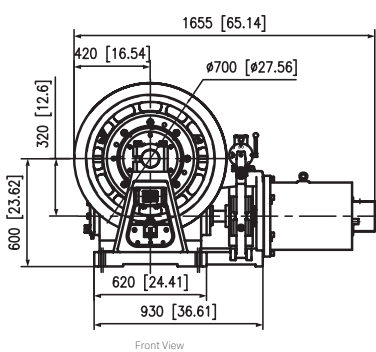

5/8" Groove Profile(U30°~96.5°)

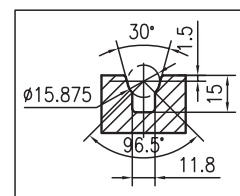

### Notes

- 1.You can choose either right hand or left hand.
- 2.V45 groove is optional.
- 3.You can choose not to be equipped with sheave clamper.



## HGD320A-SC-V45

Traction Machine	
Roping	1:1
Max Shaft Load (lbs)	27500
Weight(lbs)	3200
Sheave	8 Grooves *5/8"(U30~96.5°) *1" Pitch
Normal Brake	
Model	DRB-13E
Pick/Hold Voltage (VDC)	200/118
Pick/Hold Current (A)	4.0/2.36
Emergency Brake	
Model	JSB35
Pick/Hold Voltage (VDC)	220
Pick/Hold Current (A)	0.24/0.12

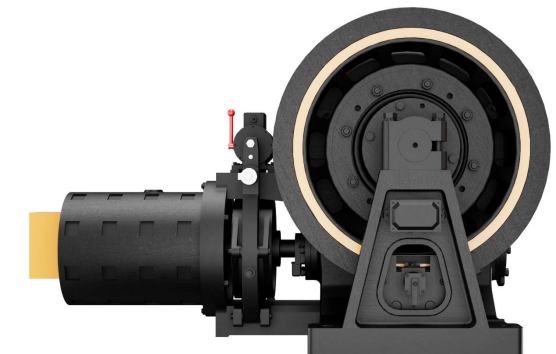

Machine Part No.	Rated Load (lbs)	Speed (fpm)	Ratio	Sheave Diameter (in)	Power (HP)	Pole	Rated Speed (Rpm)	Voltage (VAC)	Rated Frequency (Hz)	Rated Current (A)
HGD320A-3545-L-SC-V45	3500	450	82:3	27.6	50	4	1770	480	60	55
HGD320A-4535-L-SC-V45	4500	350	69:2	27.6	50	4	1770	480	60	55
HGD320A-4540-L-SC-V45	4500	400	61:2	27.6	50	4	1770	480	60	55
HGD320A-4545-L-SC-V45	4500	450	82:3	27.6	60	4	1770	480	60	66
HGD320A-5535-L-SC-V45	5500	350	69:2	27.6	50	4	1770	480	60	55
HGD320A-5545-L-SC-V45	5500	450	82:3	27.6	60	4	1770	480	60	66

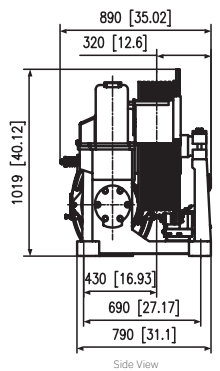
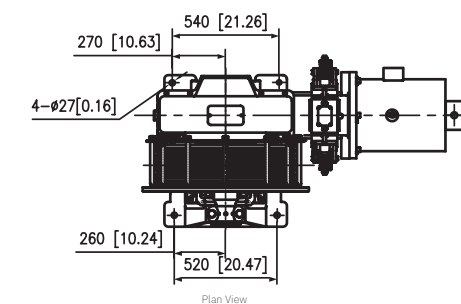
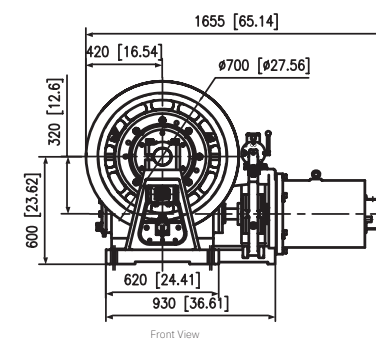

5/8" Groove Profile (Vh 45°)

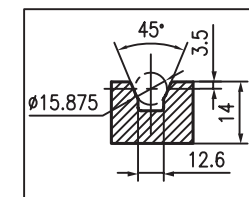

### Notes

- 1.You can choose either right hand or left hand.
- 2.You can choose not to be equipped with sheave clamper.

# OVERHEAD GEARED



## HGD410-32.3

Traction Machine	
Roping	1:1
Max Shaft Load (lbs)	55000
Weight(lbs)	6160
Sheave	10 Grooves *3/4"(U30~96.5°) *1.14" Pitch
Sheave	12 Grooves *5/8"(U30~96.5°) *1" Pitch
Normal Brake	
Model	DRB-14E
Pick/Hold Voltage (VDC)	110/70
Pick/Hold Current (A)	3.5/2
Emergency Brake	
N/A	



Machine Part No.	Rated Load (lbs)	Speed (fpm)	Ratio	Sheave Diameter (in)	Power (HP)	Pole	Rated Speed (Rpm)	Voltage (VAC)	Rated Frequency (Hz)	Rated Current (A)
HGD410-10030-HV-L	10000	300	63:2	32.3	74	6	1184	480	60	78
HGD410-12020-HV-L	12000	200	75:2	32.3	74	8	886	480	60	85

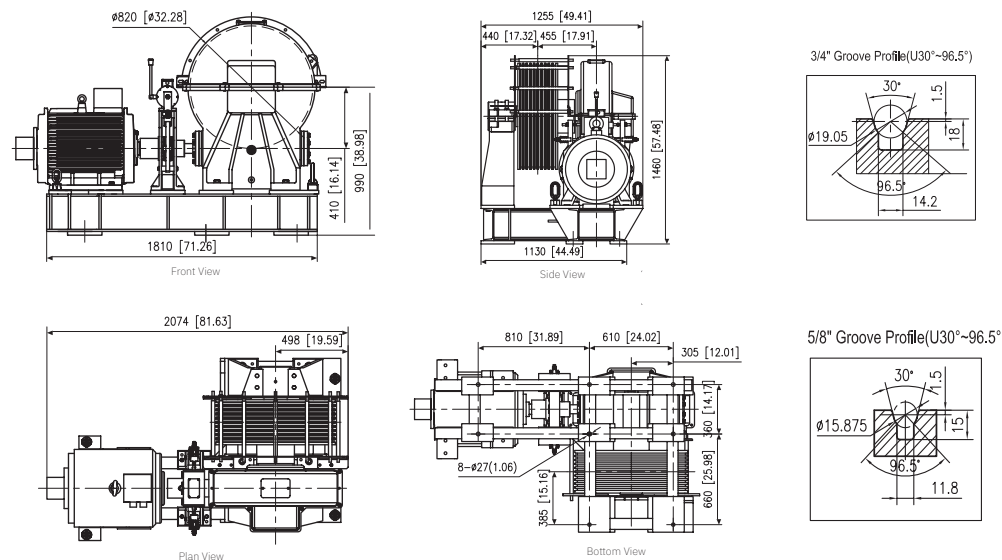

### Notes

You can choose either right hand or left hand.

# OVERHEAD GEARED



## HGD410-35.8

Traction Machine	
Roping	1:1
Max Shaft Load (lbs)	55000
Weight(lbs)	6160
Sheave	7 Grooves *3/4"(U30~96.5°) *1.14" Pitch
Sheave	8 Grooves *5/8"(U30~96.5°) *1" Pitch
Normal Brake	
Model	DRB-14E
Pick/Hold Voltage (VDC)	110/70
Pick/Hold Current (A)	3.5/2
Emergency Brake	
N/A	

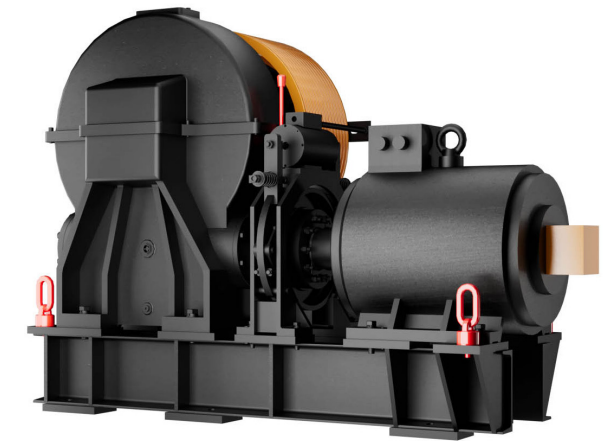

Machine Part No.	Rated Load (lbs)	Speed (fpm)	Ratio	Sheave Diameter (in)	Power (HP)	Pole	Rated Speed (Rpm)	Voltage (VAC)	Rated Frequency (Hz)	Rated Current (A)
HGD410-8035-HV-L	8000	350	63:2	35.8	74	6	1184	480	60	78

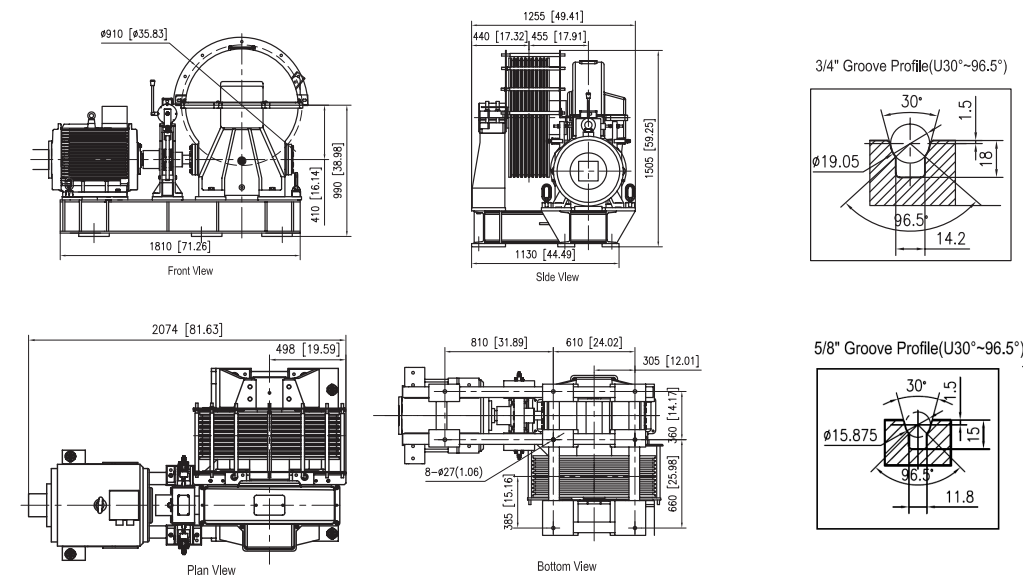

### Notes

You can choose either right hand or left hand.

# BASEMENT MACHINE

## BASEMENT MACHINE



### Basement Geared

HAIDERDRIVE

Geared Basement Machines (1:1 roping)									
Capacity (lbs)	50	100	150	200	250	300	350	400	450
1500	HGD1B								HGD320B
1760									
2000									
2500									HGD320B
3000									
3500									
4000									
4500									
5000									
5500									
6000									

### Basement Gearless

HAIDERDRIVE

Gearless Basement Machines (1:1 roping)			
Capacity (lbs)	200	350	500
2500	HGL292AB - 2520	HGL292AB - 2535	HGL292AB - 3050
3000	HGL292AB - 3035		

Gearless Basement Machines (2:1 roping)		
Capacity (lbs)	500	700
5000	HGL292AB-2-1-5050	HGL292AB-2-1-5070

### Benefits:

- Large start torque
- Large sheave diameter
- Either 1/2" or 5/8" rope
- Emergency brake as an option
- Easy maintenance
- Simple brake adjustments
- Flange mount motors dismount easily
- Bronze gear
- With incremental encoder

### Standard Features:

- Accurate Motor Control with VVVF design
- Gearbox with asynchronous motor
- Use for basement
- Drive sheave rope retainer
- Either Left or Right hand
- Roping 1:1
- Capacity up to 6000lbs
- Speed up to 450fpm
- Temperature monitoring by PTC thermistor

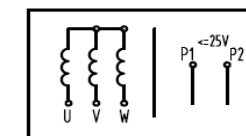

Power Wiring Diagram

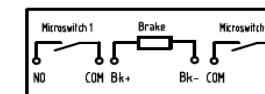

Brake Wiring Diagram

## HGD1B



## HGD1B-SC



Traction Machine	
Roping	1:1
Max Shaft Load (lbs)	14300
Weight(lbs)	2090
Sheave	6 Grooves *1/2"(U30~96.5°) *3/4" Pitch
Sheave	5 Grooves *5/8"(U30~96.5°) *1" Pitch
Normal Brake	
Model	DRB-12E
Pick/Hold Voltage (VDC)	110/65
Pick/Hold Current (A)	2.0/1.18
Emergency Brake	
N/A	

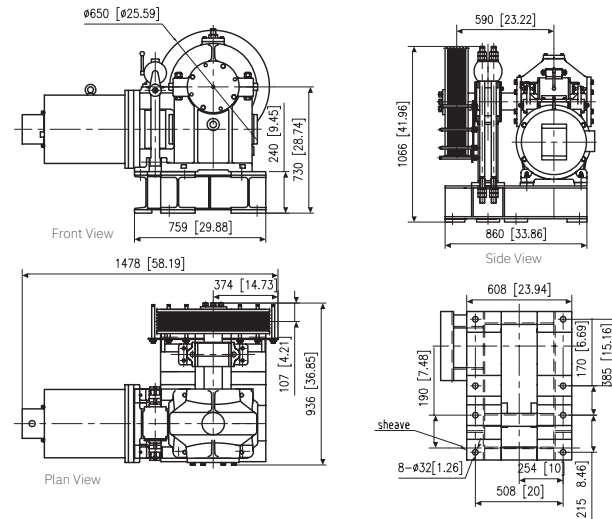

Traction Machine	
Roping	1:1
Max Shaft Load (lbs)	14300
Weight(lbs)	2450
Sheave	6 Grooves *1/2"(U30~96.5°) *3/4" Pitch
Sheave	5 Grooves *5/8"(U30~96.5°) *1" Pitch
Normal Brake	
Model	DRB-12E
Pick/Hold Voltage (VDC)	110/65
Pick/Hold Current (A)	2.0/1.18
Emergency Brake	
Model	JSB35
Pick/Hold Voltage (VDC)	220
Pick/Hold Current (A)	0.24/0.12

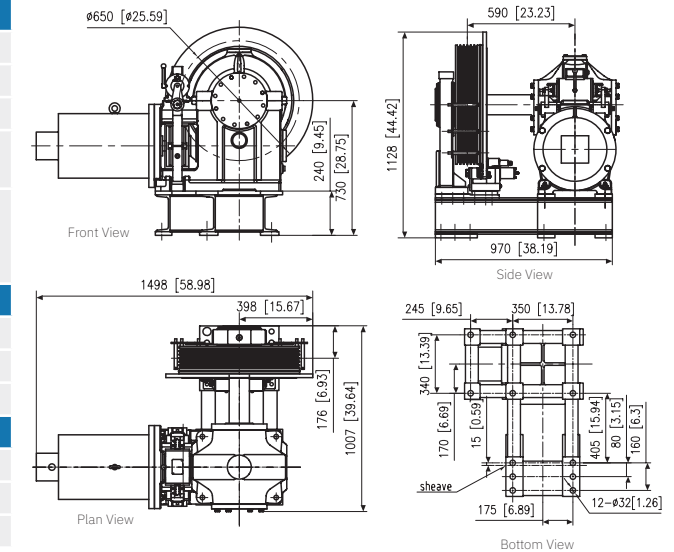

Machine Part No.	Rated Load (lbs)	Speed (fpm)	Ratio	Sheave Diameter (in)	Power (HP)	Pole	Rated Speed (Rpm)	Voltage (VAC)	Rated Frequency (Hz)	Rated Current (A)
HGD1B-2020-HV-L	2000	200	50:1	25.6	15	4	1770	480	60	17
HGD1B-2020-LV-L	2000	200	50:1	25.6	15	4	1770	208	60	39
HGD1B-2510-HV-L	2500	100	61:1	25.6	10	6	1170	480	60	14
HGD1B-2510-LV-L	2500	100	61:1	25.6	10	6	1170	208	60	32
HGD1B-2520-HV-L	2500	200	50:1	25.6	20	4	1775	480	60	23
HGD1B-2520-LV-L	2500	200	50:1	25.6	20	4	1775	208	60	53
HGD1B-2535-HV-L	2500	350	61:2	25.6	25	4	1770	480	60	28
HGD1B-2535-LV-L	2500	350	61:2	25.6	25	4	1770	208	60	64
HGD1B-2540-HV-L	2500	400	55:2	25.6	30	4	1775	480	60	33
HGD1B-2540-LV-L	2500	400	55:2	25.6	30	4	1775	208	60	75

Machine Part No.	Rated Load (lbs)	Speed (fpm)	Ratio	Sheave Diameter (in)	Power (HP)	Pole	Rated Speed (Rpm)	Voltage (VAC)	Rated Frequency (Hz)	Rated Current (A)
HGD1B-2020-HV-L-SC	2000	200	50:1	25.6	15	4	1770	480	60	17
HGD1B-2020-LV-L-SC	2000	200	50:1	25.6	15	4	1770	208	60	39
HGD1B-2510-HV-L-SC	2500	100	61:1	25.6	10	6	1170	480	60	14
HGD1B-2510-LV-L-SC	2500	100	61:1	25.6	10	6	1170	208	60	32
HGD1B-2520-HV-L-SC	2500	200	50:1	25.6	20	4	1775	480	60	23
HGD1B-2520-LV-L-SC	2500	200	50:1	25.6	20	4	1775	208	60	53
HGD1B-2535-HV-L-SC	2500	350	61:2	25.6	25	4	1770	480	60	28
HGD1B-2535-LV-L-SC	2500	350	61:2	25.6	25	4	1770	208	60	64
HGD1B-2540-HV-L-SC	2500	400	55:2	25.6	30	4	1775	480	60	33
HGD1B-2540-LV-L-SC	2500	400	55:2	25.6	30	4	1775	208	60	75

### Notes

- 1.You can choose either right hand or left hand.
- 2.You can choose either 1/2" rope or either 5/8" rope.

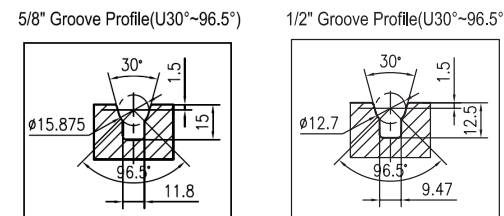

### Notes

- 1.You can choose either right hand or left hand.
- 2.You can choose either 1/2" rope or either 5/8" rope.

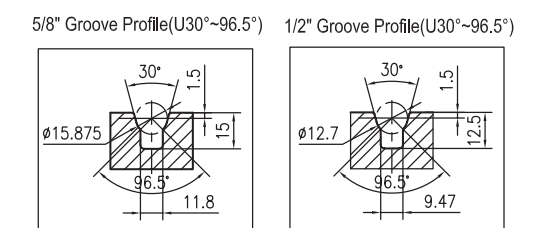

## HGD320B-27.6



Traction Machine	
Roping	1:1
Max Shaft Load (lbs)	27500
Weight(lbs)	3300
Sheave	8 Grooves *1/2"(U30~96.5°) *3/4" Pitch
Sheave	8 Grooves *5/8"(U30~96.5°) *1" Pitch
Normal Brake	
Model	DRB-13E
Pick/Hold Voltage (VDC)	200/118
Pick/Hold Current (A)	4.0/2.36
Emergency Brake	
N/A	

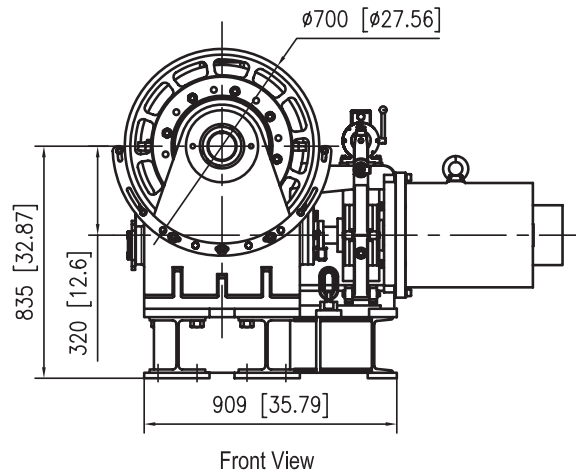

Machine Part No.	Rated Load (lbs)	Speed (fpm)	Ratio	Sheave Diameter (in)	Power (HP)	Pole	Rated Speed (Rpm)	Voltage (VAC)	Rated Frequency (Hz)	Rated Current (A)
HGD320B-4535-HV-L	4500	350	69:2	27.6	50	4	1770	480	60	55
HGD320B-4540-HV-L	4500	400	61:2	27.6	50	4	1770	480	60	55
HGD320B-5020-HV-L	5000	200	61:1	27.6	35	4	1770	480	60	40
HGD320B-6020-HV-L	6000	200	61:1	27.6	40	4	1770	480	60	45
HGD320B-6035-HV-L	6000	350	69:2	27.6	60	4	1770	480	60	66

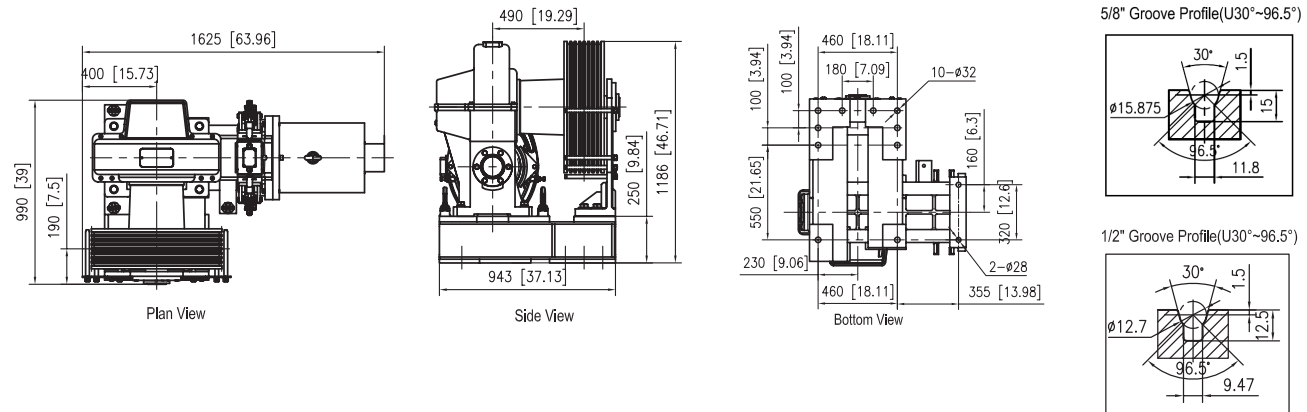

### Notes

- 1.You can choose either right hand or left hand.
- 2.You can choose either 1/2" rope or either 5/8" rope.

## HGD320B-31.5



Traction Machine	
Roping	1:1
Max Shaft Load (lbs)	27500
Weight(lbs)	3400
Sheave	8 Grooves *1/2"(U30~96.5°) *3/4" Pitch
Sheave	8 Grooves *5/8"(U30~96.5°) *1" Pitch
Normal Brake	
Model	DRB-13E
Pick/Hold Voltage (VDC)	200/118
Pick/Hold Current (A)	4.0/2.36
Emergency Brake	
N/A	

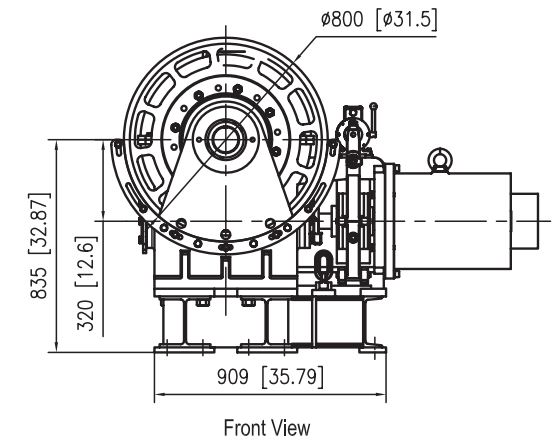

Machine Part No.	Rated Load (lbs)	Speed (fpm)	Ratio	Sheave Diameter (in)	Power (HP)	Pole	Rated Speed (Rpm)	Voltage (VAC)	Rated Frequency (Hz)	Rated Current (A)
HGD320B-3550-HV-L	3500	500	82:3	31.5	50	4	1770	480	60	55
HGD320B-4545-HV-L	4500	450	61:2	31.5	60	4	1770	480	60	66
HGD320B-6045-HV-L	6000	450	61:2	31.5	60	4	1770	480	60	66

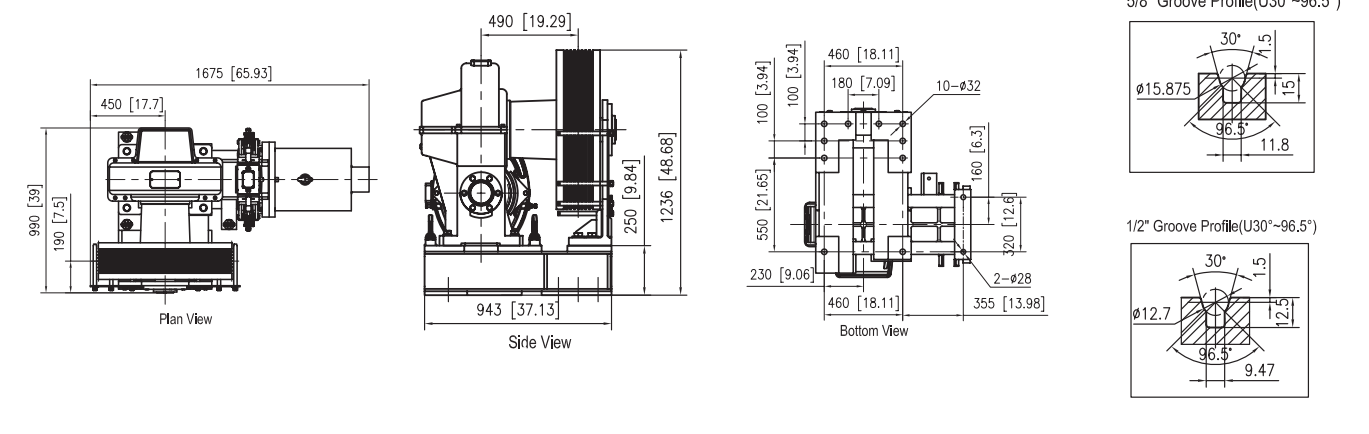

### Notes

- 1.You can choose either right hand or left hand.
- 2.You can choose either 1/2" rope or either 5/8" rope.

## HGD320B-SC



Traction Machine	
Roping	1:1
Max Shaft Load (lbs)	27500
Weight(lbs)	3520
Sheave	8 Grooves *1/2"(U30~96.5°) *3/4" Pitch
Sheave	8 Grooves *5/8"(U30~96.5°) *1" Pitch
Normal Brake	
Model	DRB-13E
Pick/Hold Voltage (VDC)	200/118
Pick/Hold Current (A)	4.0/2.36
Emergency Brake	
Model	JSB35
Pick/Hold Voltage (VDC)	220
Pick/Hold Current (A)	0.24/0.12

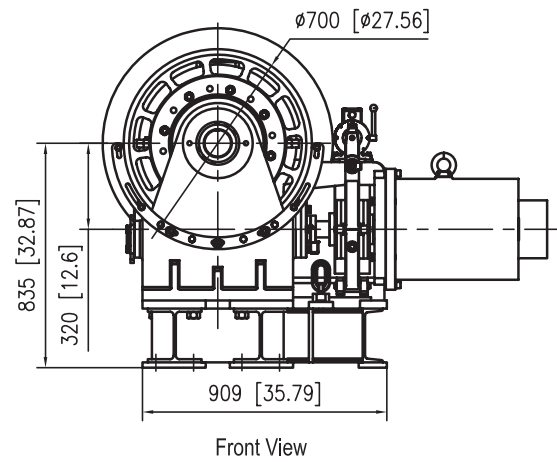

Machine Part No.	Rated Load (lbs)	Speed (fpm)	Ratio	Sheave Diameter (in)	Power (HP)	Pole	Rated Speed (Rpm)	Voltage (VAC)	Rated Frequency (Hz)	Rated Current (A)
HGD320B-3545-L-SC	3500	450	82:3	27.6	50	4	1770	480	60	55
HGD320B-4535-L-SC	4500	350	69:2	27.6	50	4	1770	480	60	55
HGD320B-4540-L-SC	4500	400	61:2	27.6	50	4	1770	480	60	55
HGD320B-4545-L-SC	4500	450	82:3	27.6	60	4	1770	480	60	66
HGD320B-5020-L-SC	5000	200	61:1	27.6	35	4	1770	480	60	40
HGD320B-5520-L-SC	5500	200	61:1	27.6	35	4	1770	480	60	40
HGD320B-5535-L-SC	5500	350	69:2	27.6	50	4	1770	480	60	55
HGD320B-5545-L-SC	5500	450	82:3	27.6	60	4	1770	480	60	66

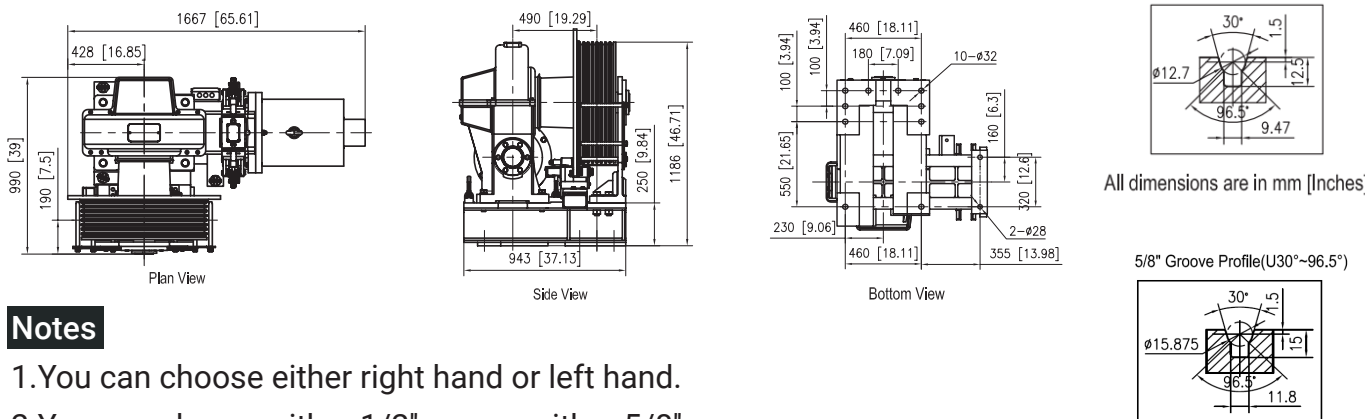

### Notes

- 1.You can choose either right hand or left hand.
- 2.You can choose either 1/2" rope or either 5/8" rope.

## HGL292AB-V45



Traction Machine	
Roping	1:1
Max Shaft Load (lbs)	11250
Weight(lbs)	2650
Sheave	6 Grooves *1/2"(Vh45°) *3/4" Pitch
Normal Brake	
Model	DIBS1600A
Pick/Hold Voltage (VDC)	90/45
Pick/Hold Current (A)	2.05/1.0
Emergency Brake	
Model	DIBS1600B
Pick/Hold Voltage (VDC)	90/45
Pick/Hold Current (A)	2.05/1.0

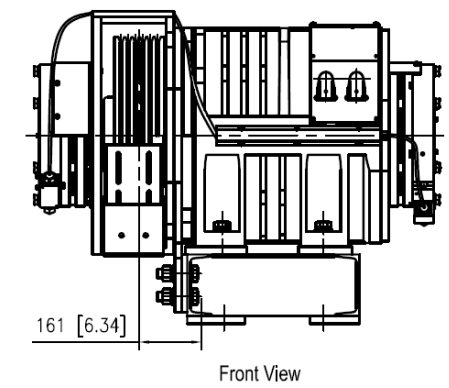

Machine Part No.	Rated Load (lbs)	Speed (fpm)	Sheave Diameter (in)	Power (HP)	Rated Speed (Rpm)	Voltage (VAC)	Rated Frequency (Hz)	Rated Current (A)	Rated Torque (lbs. ft)
HGL292AB-2520-HV-1/2-V45	2500	200	20	9.3	38	350	6.4	14.8	1272
HGL292AB-2520-LV-1/2-V45	2500	200	20	9.3	38	160	6.4	30.7	1272
HGL292AB-2535-HV-1/2-V45	2500	350	20	16.2	67	350	11.1	24.5	1272
HGL292AB-2535-LV-1/2-V45	2500	350	20	16.2	67	160	11.1	52.4	1272
HGL292AB-3035-HV-1/2-V45	3000	350	20	19.4	67	350	11.1	29.8	1527
HGL292AB-3035-LV-1/2-V45	3000	350	20	19.4	67	160	11.1	61.5	1527
HGL292AB-3050-HV-1/2-V45	3000	500	20	27.7	95	350	15.9	42	1527

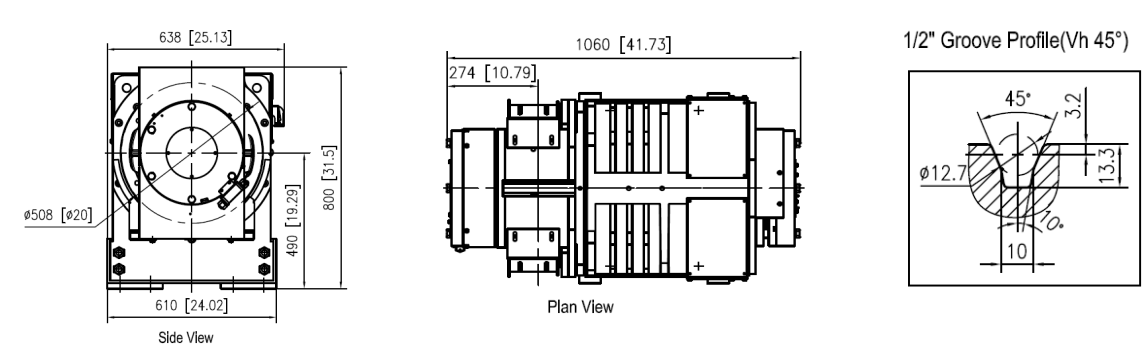

## HGL292AB



Traction Machine	
Roping	2:1
Max Shaft Load (lbs)	11250
Weight(lbs)	2650
Sheave	6 Grooves *1/2"(Vh45°) *3/4" Pitch
Normal Brake	
Model	DIBS1600A
Pick/Hold Voltage (VDC)	90/45
Pick/Hold Current (A)	2.05/1.0
Emergency Brake	
Model	DIBS1600B
Pick/Hold Voltage (VDC)	90/45
Pick/Hold Current (A)	2.05/1.0

Machine Part No.	Rated Load (lbs)	Speed (fpm)	Sheave Diameter (in)	Power (HP)	Rated Speed (Rpm)	Voltage (VAC)	Rated Frequency (Hz)	Rated Current (A)	Rated Toque (lbs. ft)
HGL292AB-5050-HV-1/2	5000	500	20	49.1	191	350	31.8	68.5	1350

## HGL292AB

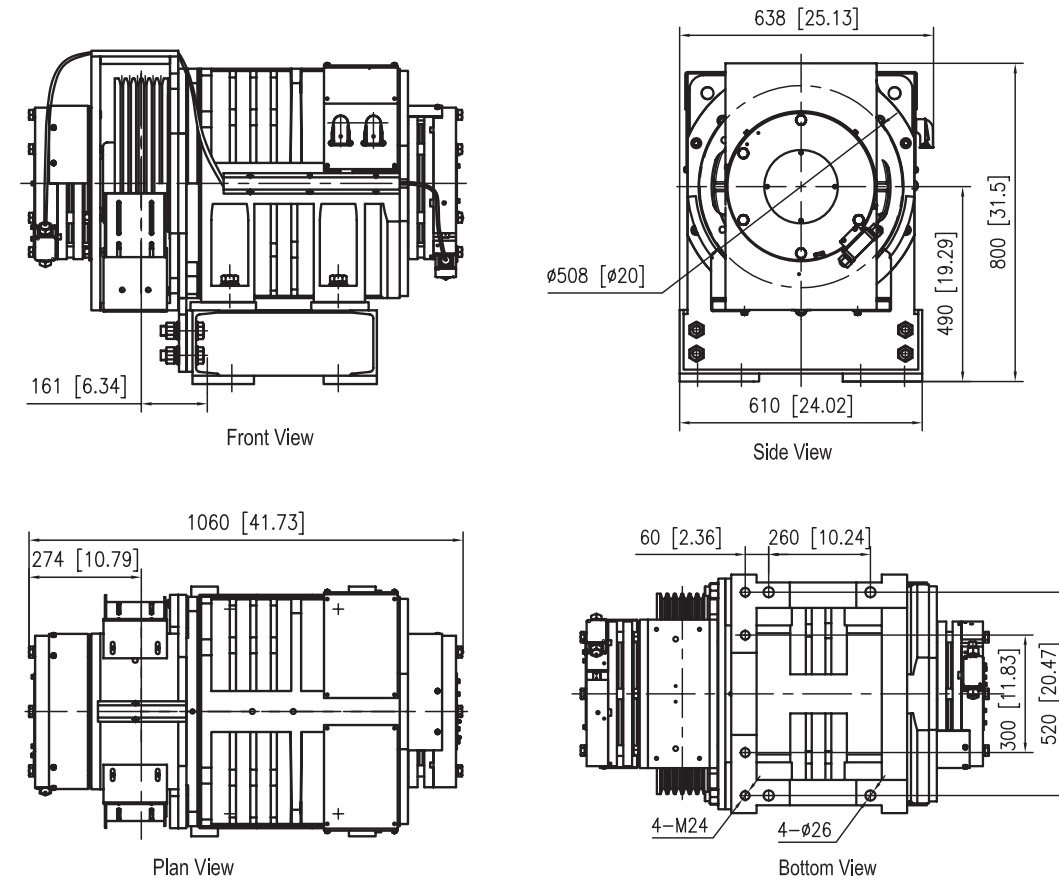

1/2" Groove Profile(Vh 40°)

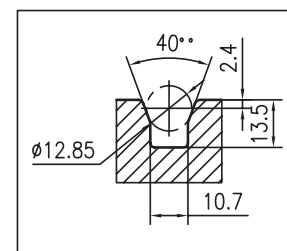

# MACHINE ROOMLESS

MRL



## HGL Series

HAIDERDRIVE

HGL Series - 8 MM Rope (2 :1 roping)						
Capacity (lbs)	Speed					
	100	150	200	250	300	350
2500	HGL280		HGL332			
	HGL205F					
3500	HGL333					
	HGL205G					

HGL Series - 10 MM Rope (2 :1) roping					
Capacity (lbs)	Speed				
	200	300	350	400	500
2500	HGL332				
3500	HGL334				
	HGL334	HGL334		HGL290	
		HGL290			
5000	HGL290				

### Benefits:

- High efficiency, low temperature rise
- Quieter operation
- Smoother start up
- Compact design
- Nearly maintenance-free
- Either 8mm or 10mm rope
- Hardened drive sheave and V groove

### Standard Features:

- AC synchronous permanent magnet design
- Use for small hoistway
- Separated controllable brake as safety device
- Drive sheave rope retainer
- Roping 2:1
- Capacity up to 5000 lbs
- Speed up to 500 fpm
- Temperature monitoring by PTC thermistor

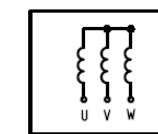

Power Wiring Diagram

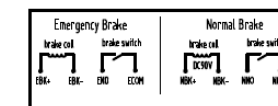

Brake Wiring Diagram

Encoder Connect Cable

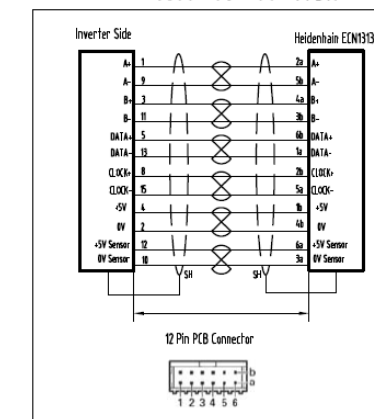



# HGL205F



Traction Machine	
Roping	2:1
Max Shaft Load (lbs)	8500
Weight(lbs)	980
Sheave	8 Grooves *8mm (Vh 45°) *14mm Pitch
Normal Brake	
Model	DIB800
Pick/Hold Voltage (VDC)	90/50
Pick/Hold Current (A)	1.25/0.69
Emergency Brake	
Model	DIB1600
Pick/Hold Voltage (VDC)	90/45
Pick/Hold Current (A)	2.05/1.0



Machine Part No.	Rated Load (lbs)	Speed (fpm)	Sheave Diameter (in)	Power (HP)	Rated Voltage (VAC)	Rated Current (A)	Rated Frequency (Hz)	Rated Speed (Rpm)	Rated Torque (lbs.ft)
HGL205F-2520-HV-8mm-V45	2500	200	12.6	10.7	340	17	20.2	121	465
HGL205F-2520-LV-8mm-V45	2500	200	12.6	10.7	178	33	20.2	121	465
HGL205F-2535-HV-8mm-V45	2500	350	12.6	18.8	340	28	35.3	212	465
HGL205F-2535-LV-8mm-V45	2500	350	12.6	18.8	176	55	35.3	212	465

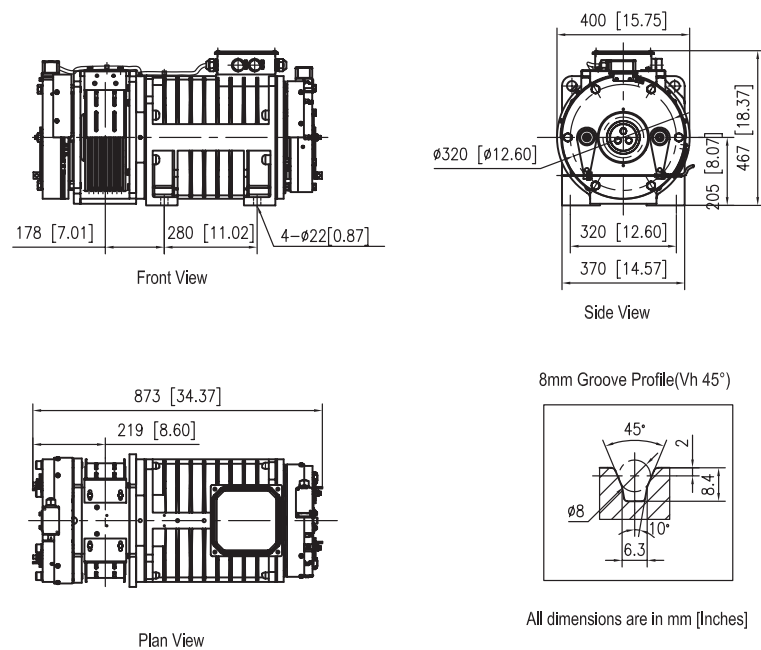

# HGL205G



Traction Machine	
Roping	2:1
Max Shaft Load (lbs)	10000
Weight(lbs)	1180
Sheave	8 Grooves *8mm (Vh 45°) *14mm Pitch
Normal Brake	
Model	DIB1600
Pick/Hold Voltage (VDC)	90/45
Pick/Hold Current (A)	2.05/1.0
Emergency Brake	
Model	DIB1600
Pick/Hold Voltage (VDC)	90/45
Pick/Hold Current (A)	2.05/1.0



Machine Part No.	Rated Load (lbs)	Speed (fpm)	Sheave Diameter (in)	Power (HP)	Rated Voltage (VAC)	Rated Current (A)	Rated Frequency (Hz)	Rated Speed (Rpm)	Rated Torque (lbs.ft)
HGL205G-3520-HV-8mm-V45	3500	200	12.6	14.8	340	23	20.2	121	642
HGL205G-3520-LV-8mm-V45	3500	200	12.6	14.8	182	44	20.2	121	642
HGL205G-3535-HV-8mm-V45	3500	350	12.6	25.9	340	40	35.3	212	642

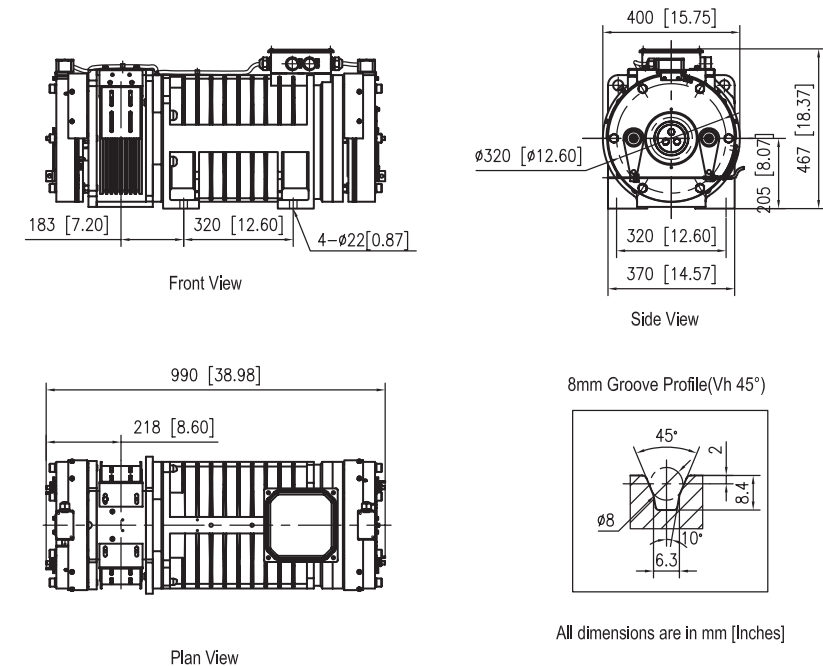



# HGL280

Traction Machine	
Roping	2:1
Max Shaft Load (lbs)	6587
Weight(lbs)	660
Sheave	4 Grooves *8mm (Vh 40°) *14mm Pitch
Normal Brake	
Model	BLB12
Pick/Hold Voltage (VDC)	90/45
Pick/Hold Current (A)	1.2/0.6
Emergency Brake	
Model	BLB12
Pick/Hold Voltage (VDC)	90/45
Pick/Hold Current (A)	1.2/0.6

Machine Part No.	Rated Load (lbs)	Speed (fpm)	Sheave Diameter (in)	Power (HP)	Rated Voltage (VAC)	Rated Current (A)	Rated Frequency (Hz)	Rated Speed (Rpm)	Rated Torque (lbs.ft)
HGL280-2515-HV-8mm	2500	150	13.4	6.7	290	13.5	14.3	86	410
HGL280-2515-LV-8mm	2500	150	13.4	6.7	145	26.5	14.3	86	410

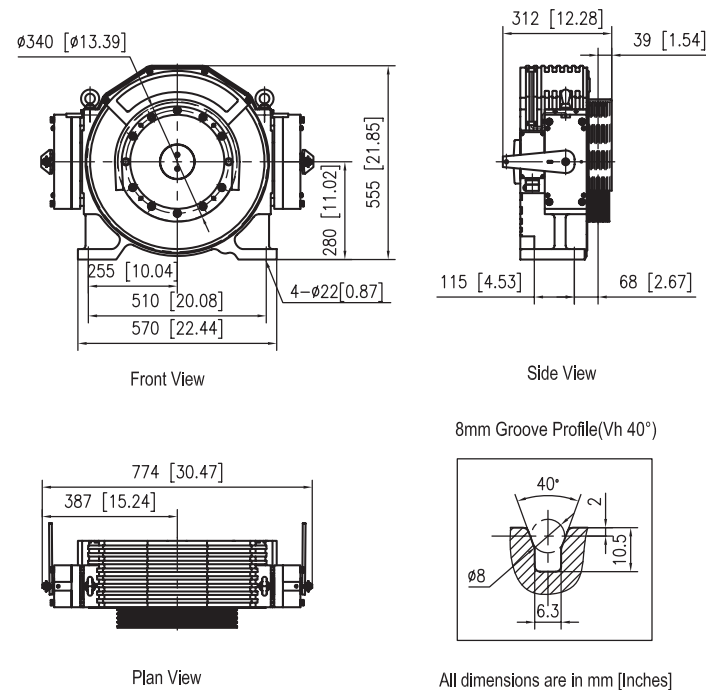

# HGL290-V45

Traction Machine	
Roping	2:1
Max Shaft Load (lbs)	12817
Weight(lbs)	2090
Sheave	8*Grooves *10mm (Vh 45°) *16mm Pitch
Normal Brake	
Model	DIB1600
Pick/Hold Voltage (VDC)	90/45
Pick/Hold Current (A)	2.05/1.0
Emergency Brake	
Model	DIBS1600A
Pick/Hold Voltage (VDC)	90/45
Pick/Hold Current (A)	2.05/1.0

Machine Part No.	Rated Load (lbs)	Speed (fpm)	Sheave Diameter (in)	Power (HP)	Rated Voltage (VAC)	Rated Current (A)	Rated Frequency (Hz)	Rated Speed (Rpm)	Rated Torque (lbs.ft)
HGL290-3535-V45	3500	350	17.32	21.9	350	32.9	25.8	155	743
HGL290-3550-V45	3500	500	17.32	31.3	350	46.5	35.8	221	743
HGL290-5020-V45	5000	200	17.32	17.6	350	27.6	14.5	87	1061
HGL290-5035-V45	5000	350	17.32	31.3	350	46.9	25.8	155	1061
HGL290-5050-V45	5000	500	17.32	45	350	66.7	36.8	221	1061

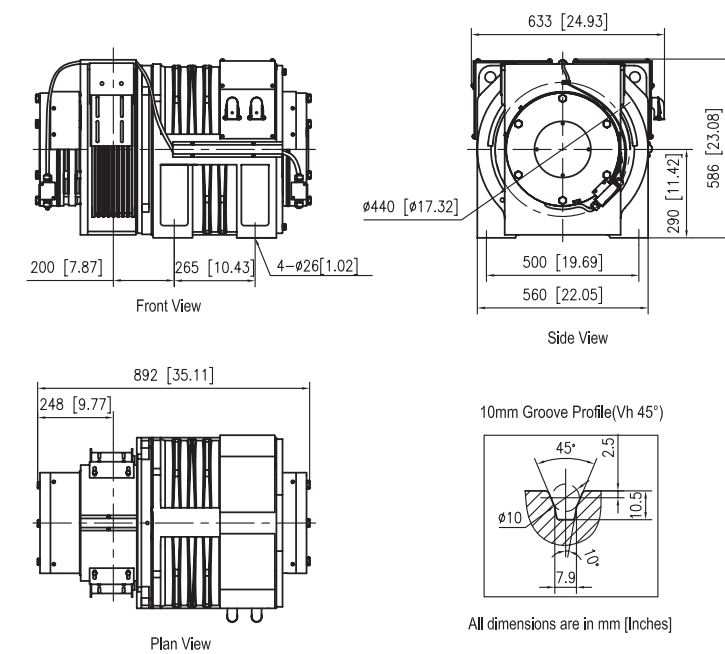
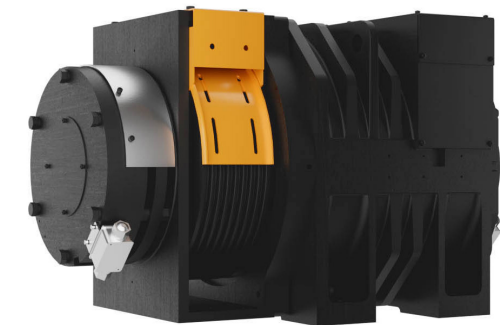

# HGL332-8mm



Traction Machine	
Roping	2:1
Max Shaft Load (lbs)	6587
Weight(lbs)	990
Sheave	7 Grooves *8mm (Vh 40°) *14mm Pitch
Normal Brake	
Model	DIB140MA1
Pick/Hold Voltage (VDC)	90/45
Pick/Hold Current (A)	0.87/0.44
Emergency Brake	
Model	DIB140MA1
Pick/Hold Voltage (VDC)	90/45
Pick/Hold Current (A)	0.87/0.44

Machine Part No.	Rated Load (lbs)	Speed (fpm)	Sheave Diameter (in)	Power (HP)	Rated Voltage (VAC)	Rated Current (A)	Rated Frequency (Hz)	Rated Speed (Rpm)	Rated Toque (lbs.ft)
HGL332-2520-HV-8mm	2500	200	13.4	10.6	328	17.7	18.7	112	494
HGL332-2520-LV-8mm	2500	200	13.4	10.6	160	35.8	18.7	112	494
HGL332-2535-HV-8mm	2500	350	13.4	18.7	328	30.4	33	198	494
HGL332-2535-LV-8mm	2500	350	13.4	18.7	160	61.5	33	198	494

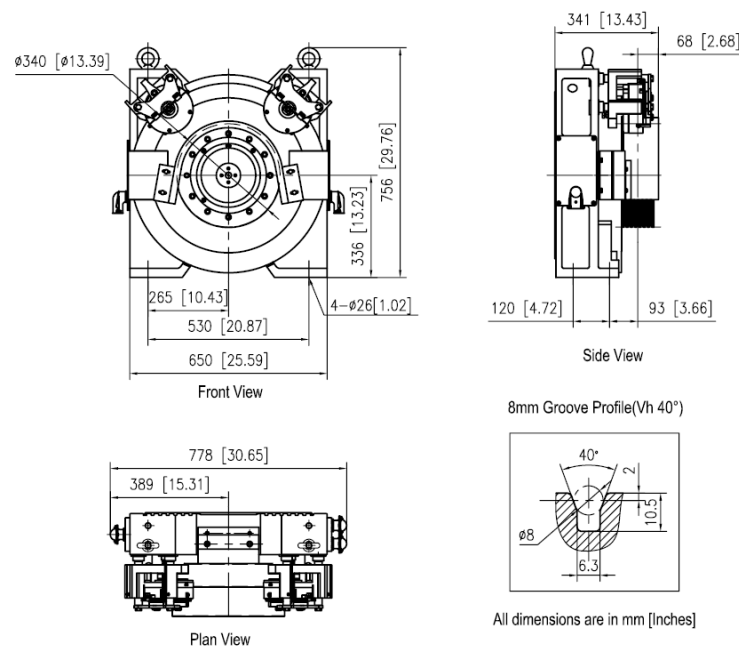

All dimensions are in mm [Inches]

# HGL332-10mm



Traction Machine	
Roping	2:1
Max Shaft Load (lbs)	6587
Weight(lbs)	1012
Sheave	6 Grooves *10mm (Vh 40°) *16mm Pitch
Normal Brake	
Model	DIB140MB1
Pick/Hold Voltage (VDC)	90/45
Pick/Hold Current (A)	1.08/0.54
Emergency Brake	
Model	DIB140MB1
Pick/Hold Voltage (VDC)	90/45
Pick/Hold Current (A)	1.08/0.54

Machine Part No.	Rated Load (lbs)	Speed (fpm)	Sheave Diameter (in)	Power (HP)	Rated Voltage (VAC)	Rated Current (A)	Rated Frequency (Hz)	Rated Speed (Rpm)	Rated Toque (lbs.ft)
HGL332-2520-HV-10mm	2500	200	15.75	9	328	15.7	16	96	494
HGL332-2520-LV-10mm	2500	200	15.75	9	160	30.6	16	96	494
HGL332-2535-HV-10mm	2500	350	15.75	15.7	328	26.7	27.8	167	494
HGL332-2535-LV-10mm	2500	350	15.75	15.7	160	53.7	27.8	167	494

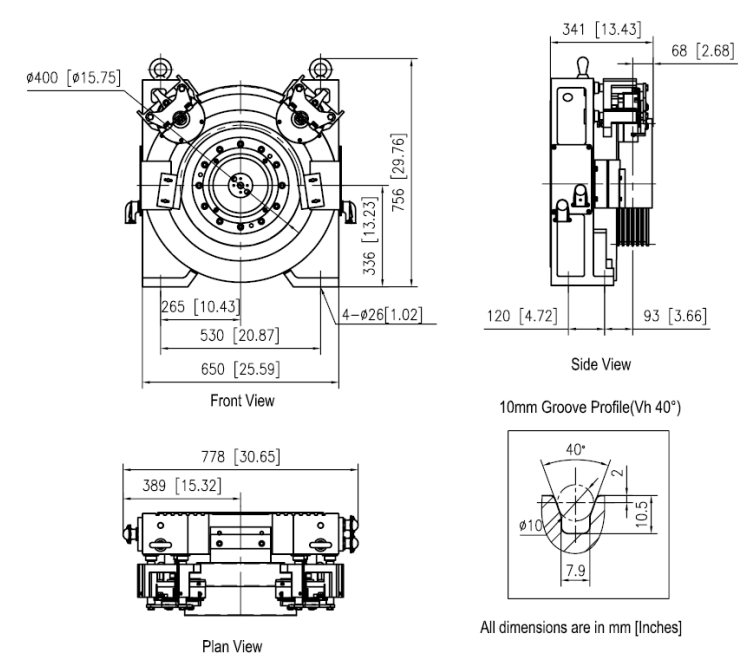

All dimensions are in mm [Inches]



# HGL333

Traction Machine	
Roping	2:1
Max Shaft Load (lbs)	9900
Weight(lbs)	1045
Sheave	7 Grooves *8mm (Vh 40°) *14mm Pitch
Normal Brake	
Model	DIB140MB1
Pick/Hold Voltage (VDC)	90/45
Pick/Hold Current (A)	1.08/0.54
Emergency Brake	
Model	DIB140MB1
Pick/Hold Voltage (VDC)	90/45
Pick/Hold Current (A)	1.08/0.54

Machine Part No.	Rated Load (lbs)	Speed (fpm)	Sheave Diameter (in)	Power (HP)	Rated Voltage (VAC)	Rated Current (A)	Rated Frequency (Hz)	Rated Speed (Rpm)	Rated Toque (lbs.ft)
HGL333-3520-HV-8mm	3500	200	13.4	12.6	328	20.3	18.7	112	590
HGL333-3520-LV-8mm	3500	200	13.4	12.6	160	42.8	18.7	112	590
HGL333-3535-HV-8mm	3500	350	13.4	22.3	328	35.2	33	198	590
HGL333-3535-LV-8mm	3500	350	13.4	22.3	160	70.4	33	198	590

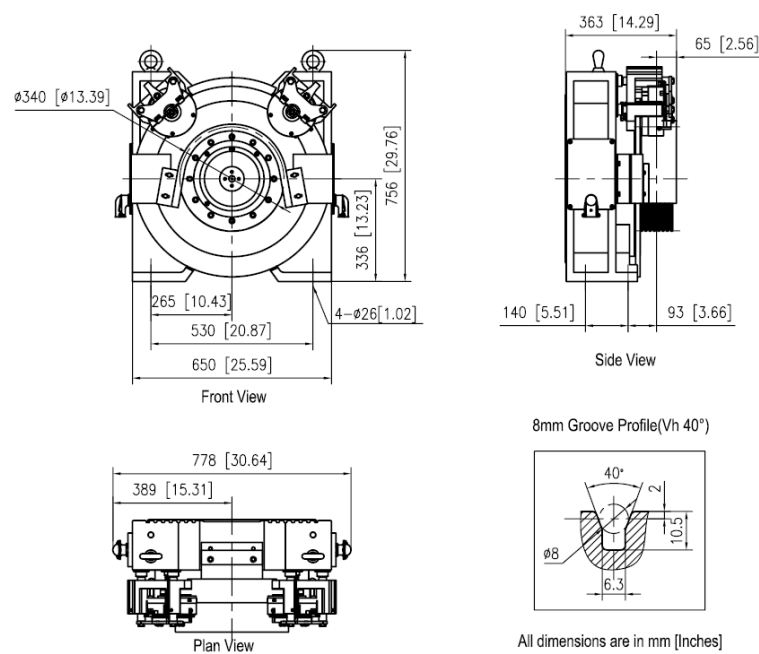

All dimensions are in mm [Inches]



# HGL334

Traction Machine	
Roping	2:1
Max Shaft Load (lbs)	9900
Weight(lbs)	1188
Sheave	6 Grooves *10mm (Vh 40°) *16mm Pitch
Normal Brake	
Model	DIB140MB1
Pick/Hold Voltage (VDC)	90/45
Pick/Hold Current (A)	1.08/0.54
Emergency Brake	
Model	DIB140MA1 (2 units)
Pick/Hold Voltage (VDC)	90/45
Pick/Hold Current (A)	0.87/0.44

Machine Part No.	Rated Load (lbs)	Speed (fpm)	Sheave Diameter (in)	Power (HP)	Rated Voltage (VAC)	Rated Current (A)	Rated Frequency (Hz)	Rated Speed (Rpm)	Rated Toque (lbs.ft)
HGL334-3520-HV-10mm	3500	200	15.75	12.3	328	21.1	16	96	676
HGL334-3520-LV-10mm	3500	200	15.75	12.3	160	40	16	96	676
HGL334-3535-HV-10mm	3500	350	15.75	21.6	328	34	27.8	167	676
HGL334-3535-LV-10mm	3500	350	15.75	21.6	160	67	27.8	167	676

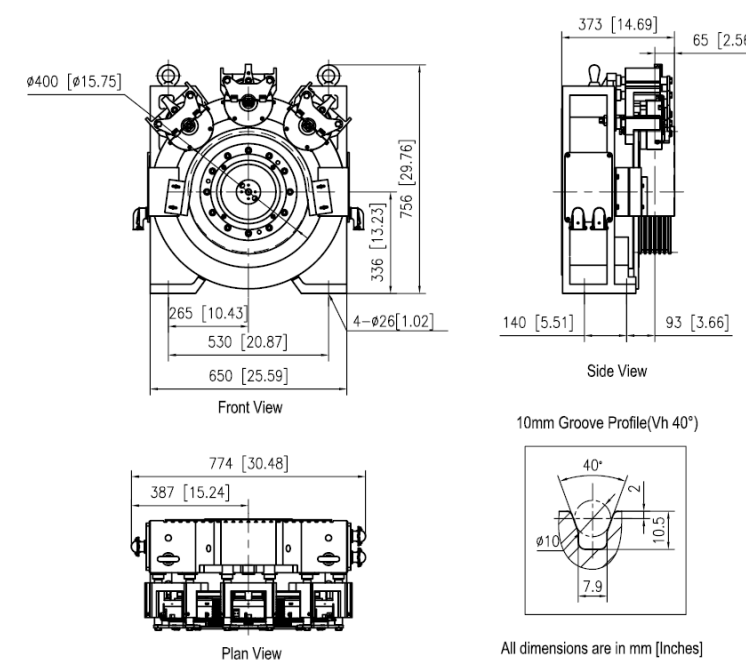

All dimensions are in mm [Inches]

# ECO GEARLESS MACHINE

## ECO GEARLESS



### HGL Series

HAIDERDRIVE

HGL Series (1:1 roping)			
	Speed		
Capacity (lbs)	200	350	500
2500	HGL292A (508mm)		
3000			
3500	HGL292 (410mm)		
4500	HGL320		

HGL Series (2:1 roping)		
	Speed	
Capacity (lbs)	500	700
5000	HGL292A (508mm)	

### Benefits:

- High efficiency, low temperature rise
- Quieter operation
- Smoother start up
- Compact design
- Nearly maintenance-free
- Either 1/2" or 5/8" rope
- Hardened drive sheave and V groove
- Replacement of geared machine as Option

### Standard Features:

- AC synchronous permanent magnet design
- Either MR or MRL
- Separated controllable brake as safety device
- Drive sheave rope retainer
- Roping 2:1 or 1:1
- Capacity up to 5000lbs(2:1) or 4500lbs(1:1)
- Speed up to 700fpm(2:1) or 500fpm(1:1)
- Temperature monitoring by PTC thermistor

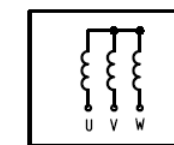

Power Wiring Diagram

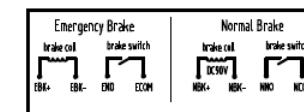

Brake Wiring Diagram

Encoder Connect Cable

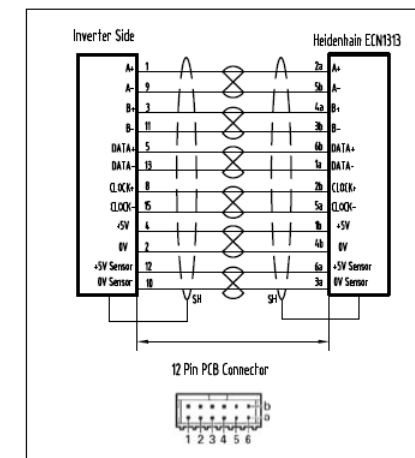



## HGL292-V45

Traction Machine	
Roping	1:1
Max Shaft Load (lbs)	20000
Weight(lbs)	2500
Sheave	10 Grooves *10mm (Vh 45°) *16mm Pitch
Normal Brake	
Model	DIBS1600A
Pick/Hold Voltage (VDC)	90/45
Pick/Hold Current (A)	2.05/1.0
Emergency Brake	
Model	DIBS1600B
Pick/Hold Voltage (VDC)	90/45
Pick/Hold Current (A)	2.05/1.0

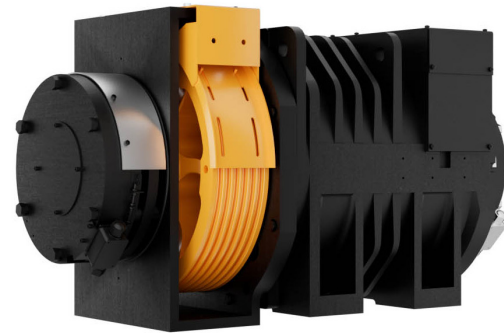

Machine Part No.	Rated Load (lbs)	Speed (fpm)	Sheave Diameter (in)	Power (HP)	Rated Voltage (VAC)	Rated Current (A)	Rated Frequency (Hz)	Rated Speed (Rpm)	Rated Toque (lbs.ft)
HGL292-3520-V45	3500	200	16.14	12.9	350	22.3	7.9	47	1438
HGL292-3535-V45	3500	350	16.14	22.7	350	36.5	13.8	83	1438
HGL292-3550-V45	3500	500	16.14	32.4	350	50	19.7	118	1438

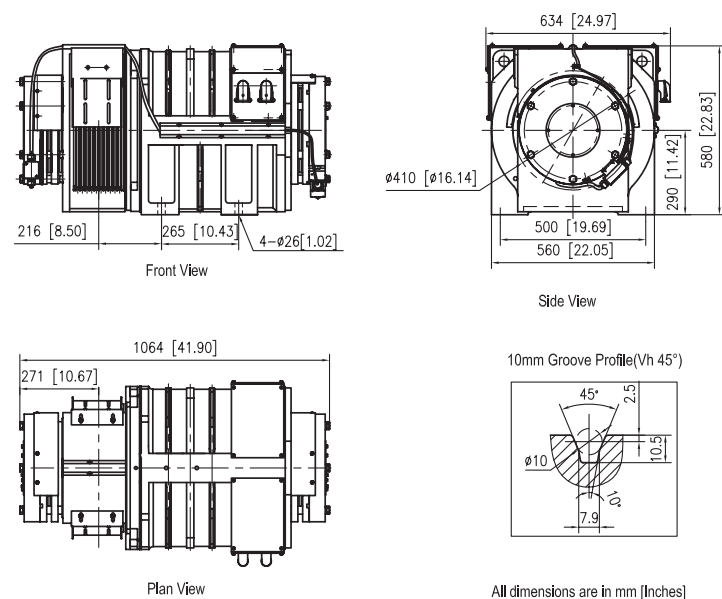

## HGL292A

Traction Machine	
Roping	2:1
Weight(lbs)	2500
Sheave	6*Grooves *1/2" (Vh 45°) *3/4" Pitch
Normal Brake	
Model	DIBS1600A
Pick/Hold Voltage (VDC)	90/45
Pick/Hold Current (A)	2.05/1.0
Emergency Brake	
Model	DIBS1600B
Pick/Hold Voltage (VDC)	90/45
Pick/Hold Current (A)	2.05/1.0

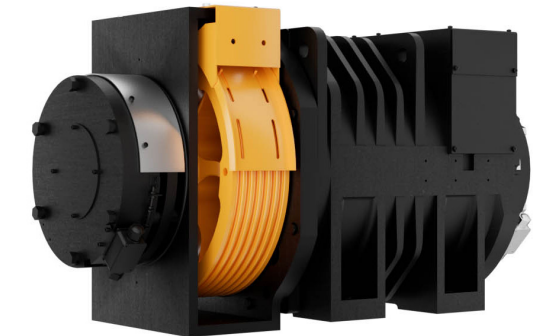

Machine Part No.	Rated Load (lbs)	Speed (fpm)	Sheave Diameter (in)	Power (HP)	Rated Voltage (VAC)	Rated Current (A)	Rated Frequency (Hz)	Rated Speed (Rpm)	Rated Toque (lbs.ft)	Max Shaft Load (lbs)
HGL292A-5050-HV-1/2	5000	500	20	49.1	350	68.5	31.8	191	1350	20000
HGL292A-5070-HV-1/2	5000	700	20	72.2	350	108	44.5	267	1420	17500

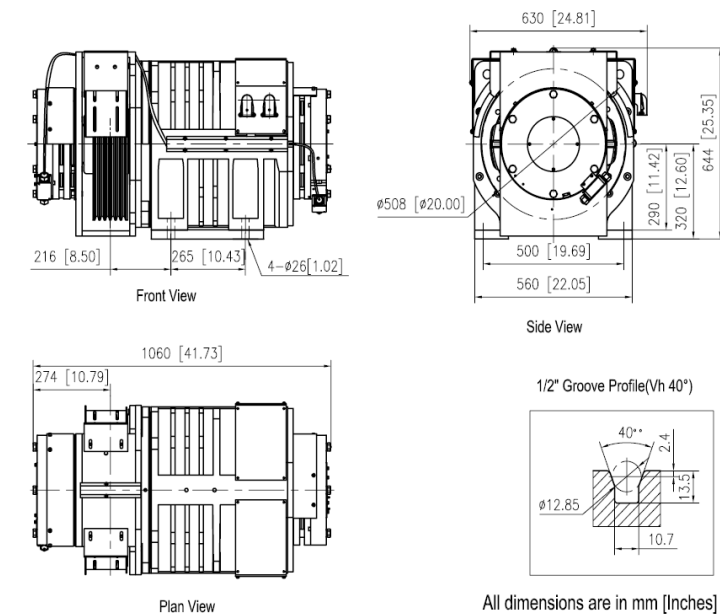

## HGL292A-V45



Traction Machine	
Roping	1:1
Max Shaft Load (lbs)	20000
Weight(lbs)	2500
Sheave	6 Grooves *1/2" (Vh 45°) *3/4" Pitch
Normal Brake	
Model	DIBS1600A
Pick/Hold Voltage (VDC)	90/45
Pick/Hold Current (A)	2.05/1.0
Emergency Brake	
Model	DIBS1600B
Pick/Hold Voltage (VDC)	90/45
Pick/Hold Current (A)	2.05/1.0

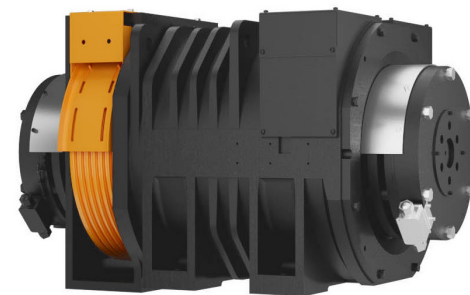

Machine Part No.	Rated Load (lbs)	Speed (fpm)	Sheave Diameter (in)	Power (HP)	Rated Voltage (VAC)	Rated Current (A)	Rated Frequency (Hz)	Rated Speed (Rpm)	Rated Toque (lbs.ft)
HGL292A-2520-HV-1/2-V45	2500	200	20	9.3	350	14.8	6.4	38	1272
HGL292A-2520-LV-1/2-V45	2500	200	20	9.3	160	30.7	6.4	38	1272
HGL292A-2535-HV-1 /2-V45	2500	350	20	16.2	350	24.5	11.1	67	1272
HGL292A-2535-LV-1/2-V45	2500	350	20	16.2	160	52.4	11.1	67	1272
HGL292A-3035-HV-1 /2-V45	3000	350	20	19.4	350	29.8	11.1	67	1527
HGL292A-3035-LV-1 /2-V45	3000	350	20	19.4	160	61.5	11.1	67	1527
HGL292A-3050-HV-1/2-V45	3000	500	20	27.7	350	42	15.9	95	1527

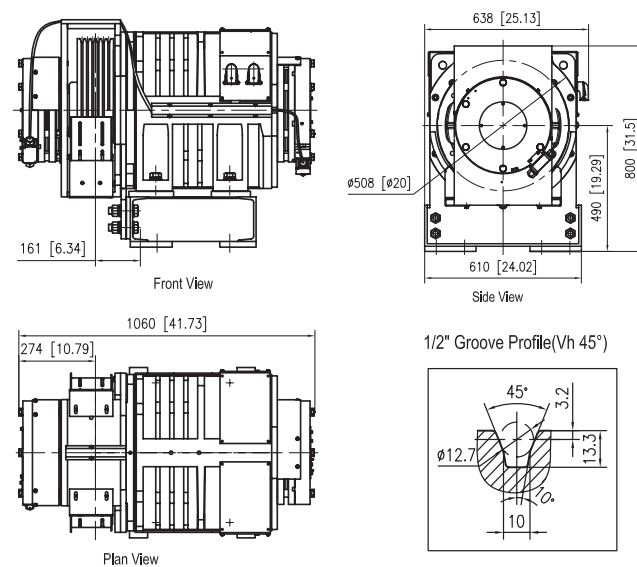

## HGL320-V45



Traction Machine	
Roping	1:1
Max Shaft Load (lbs)	25000
Weight(lbs)	3000
Sheave	10*Grooves *1/2" (Vh 45°) *3/4" Pitch
Normal Brake	
Model	DIBS1600A (2 unit)
Pick/Hold Voltage (VDC)	90/45
Pick/Hold Current (A)	2.05/1.0

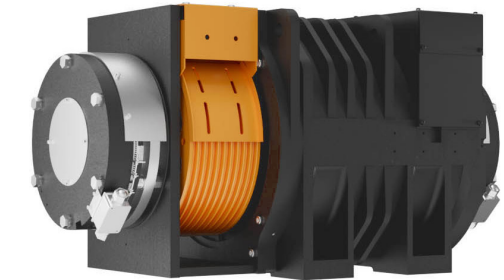

Machine Part No.	Rated Load (lbs)	Speed (fpm)	Sheave Diameter (in)	Power (HP)	Rated Voltage (VAC)	Rated Current (A)	Rated Frequency (Hz)	Rated Speed (Rpm)	Rated Toque (lbs.ft)
HGL320-4535-HV-1/2-V45	4500	350	20	31.9	350	49	11.1	67	2497

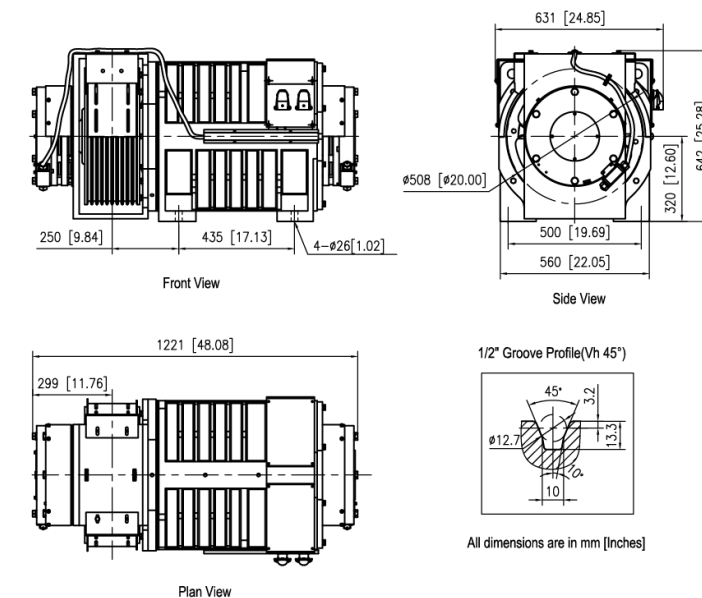

# PRO GEARLESS MACHINE

## Benefits:

- High efficiency, low temperature rise
- Quieter operation
- Smoother start up
- Large capacity and high speed
- Nearly maintenance-free
- Either single or double wrap

## Standard Features:

- AC synchronous permanent magnet design
- Separated controllable brake as safety device
- Drive sheave rope retainer
- Roping 2:1 or 1:1
- Capacity up to 8000lbs (2:1) or 5000lbs (1:1)
- Speed up to 800fpm (2:1) or 1400fpm (1:1)
- Temperature monitoring by PTC thermistor

# PRO GEARLESS



## HGL Series

HAIDERDRIVE

HGL Series (2:1 roping)				
Capacity (lbs)	Speed			
	500	600	700	800
3500	HGL401			
5000	HGL402			
8000	HGL403			

HGL Series (1:1 roping)							
Capacity (lbs)	Speed						
	350	500	700	800	1000	1200	1400
3500	HGL402			HGL402A	HGL403		
4000	HGL402A						
5000	HGL403A						

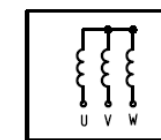

Power Wiring Diagram

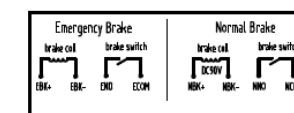

Brake Wiring Diagram

Encoder Connect Cable

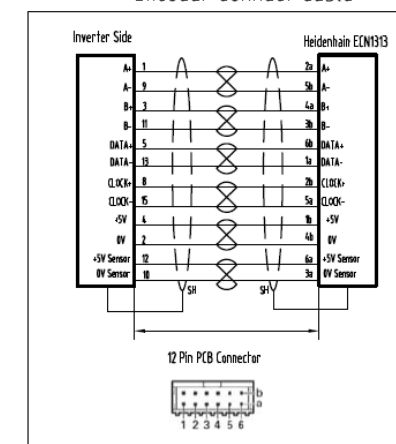



# HGL401



Traction Machine	
Roping	2:1
Max Shaft Load (lbs)	22040
Weight(lbs)	3520
Sheave	14 Grooves *1/2" (DW 26.8°) *5/8" Pitch
Normal Brake	
Model	DIB300
Pick/Hold Voltage (VDC)	110/55
Pick/Hold Current (A)	2.3/1.15
Emergency Brake	
Model	DIB300
Pick/Hold Voltage (VDC)	110/55
Pick/Hold Current (A)	2.3/1.15



Machine Part No.	Rated Load (lbs)	Speed (fpm)	Sheave Diameter (in)	Power (HP)	Rated Voltage (VAC)	Rated Current (A)	Rated Frequency (Hz)	Rated Speed (Rpm)	Rated Toque (lbs.ft)
HGL401-3550	3500	500	22	34.3	340	50	28.8	173	1040
HGL401-3570	3500	700	22	48.2	340	69	40.5	243	1040
HGL401-3580	3500	800	22	54.9	340	79	46.2	277	1040

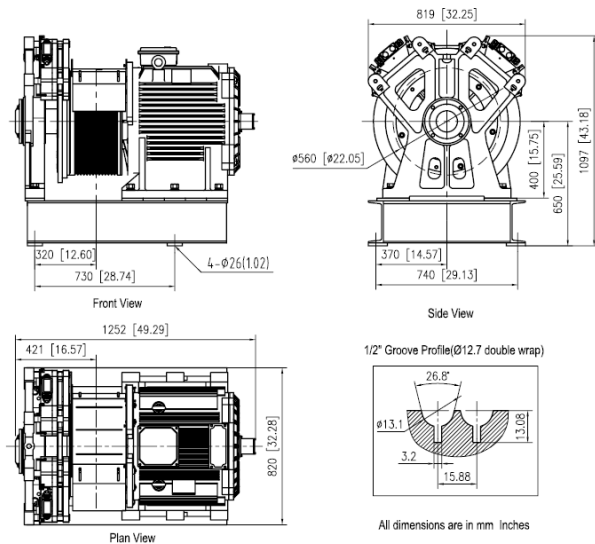

**Notes**

As shown is double wrapping, single wrapping is optional.

# HGL402-1



Traction Machine	
Roping	1:1
Max Shaft Load (lbs)	34869
Weight(lbs)	4400
Sheave	16 Grooves *1/2" (DW 26.8°) *5/8" Pitch
Normal Brake	
Model	DIB300A
Pick/Hold Voltage (VDC)	110/55
Pick/Hold Current (A)	2.3/1.15
Emergency Brake	
Model	DIB300A
Pick/Hold Voltage (VDC)	110/55
Pick/Hold Current (A)	2.3/1.15

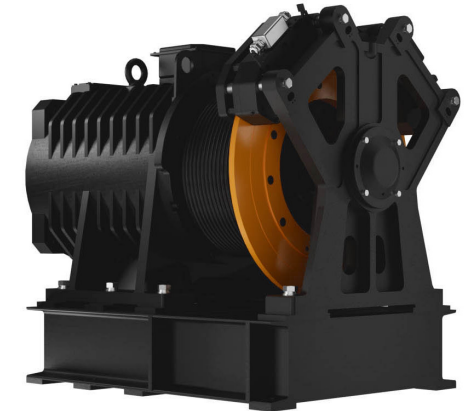

Machine Part No.	Rated Load (lbs)	Speed (fpm)	Sheave Diameter (in)	Power (HP)	Rated Voltage (VAC)	Rated Current (A)	Rated Frequency (Hz)	Rated Speed (Rpm)	Rated Toque (lbs.ft)
HGL402-3535-HV-DW	3500	350	20.47	22.7	300	42	10.9	65	1825
HGL402-3535-LV-DW	3500	350	20.47	22.7	146	87	10.9	65	1825
HGL402-3550-HV-DW	3500	500	20.47	33	320	56	15.5	93	1825
HGL402-3550-LV-DW	3500	500	20.47	33	145	121	15.5	93	1825
HGL402-3570-HV-DW	3500	700	20.47	45.5	320	76	21.8	131	1825
HGL402-3570-LV-DW	3500	700	20.47	45.5	140	173	21.8	131	1825

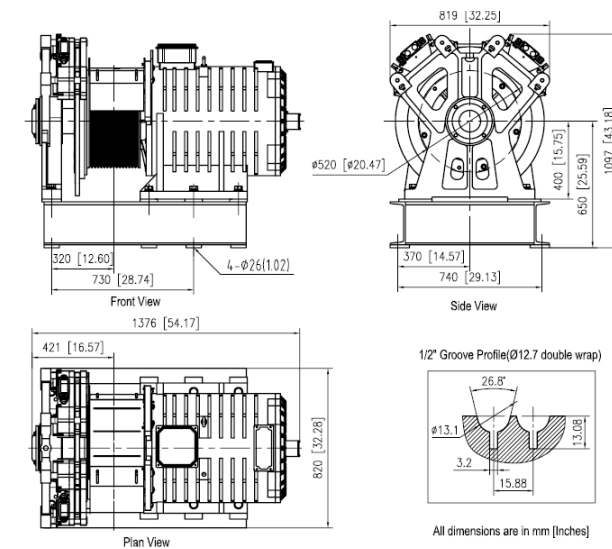

**Notes**

As shown is double wrapping, single wrapping is optional.

# HGL402-2



Traction Machine	
Roping	2:1
Max Shaft Load (lbs)	34869
Weight(lbs)	4400
Sheave	16 Grooves *1/2" (DW 26.8°) *5/8" Pitch
Normal Brake	
Model	DIB300A
Pick/Hold Voltage (VDC)	110/55
Pick/Hold Current (A)	2.3/1.15
Emergency Brake	
Model	DIB300A
Pick/Hold Voltage (VDC)	110/55
Pick/Hold Current (A)	2.3/1.15



Machine Part No.	Rated Load (lbs)	Speed (fpm)	Sheave Diameter (in)	Power (HP)	Rated Voltage (VAC)	Rated Current (A)	Rated Frequency (Hz)	Rated Speed (Rpm)	Rated Toque (lbs.ft)
HGL402-5050	5000	500	22	49	340	77	28.8	173	1485
HGL402-5070	5000	700	22	68.8	340	99.8	40.5	243	1485
HGL402-5080	5000	800	22	78.4	340	125	46.2	277	1485

# HGL402-2

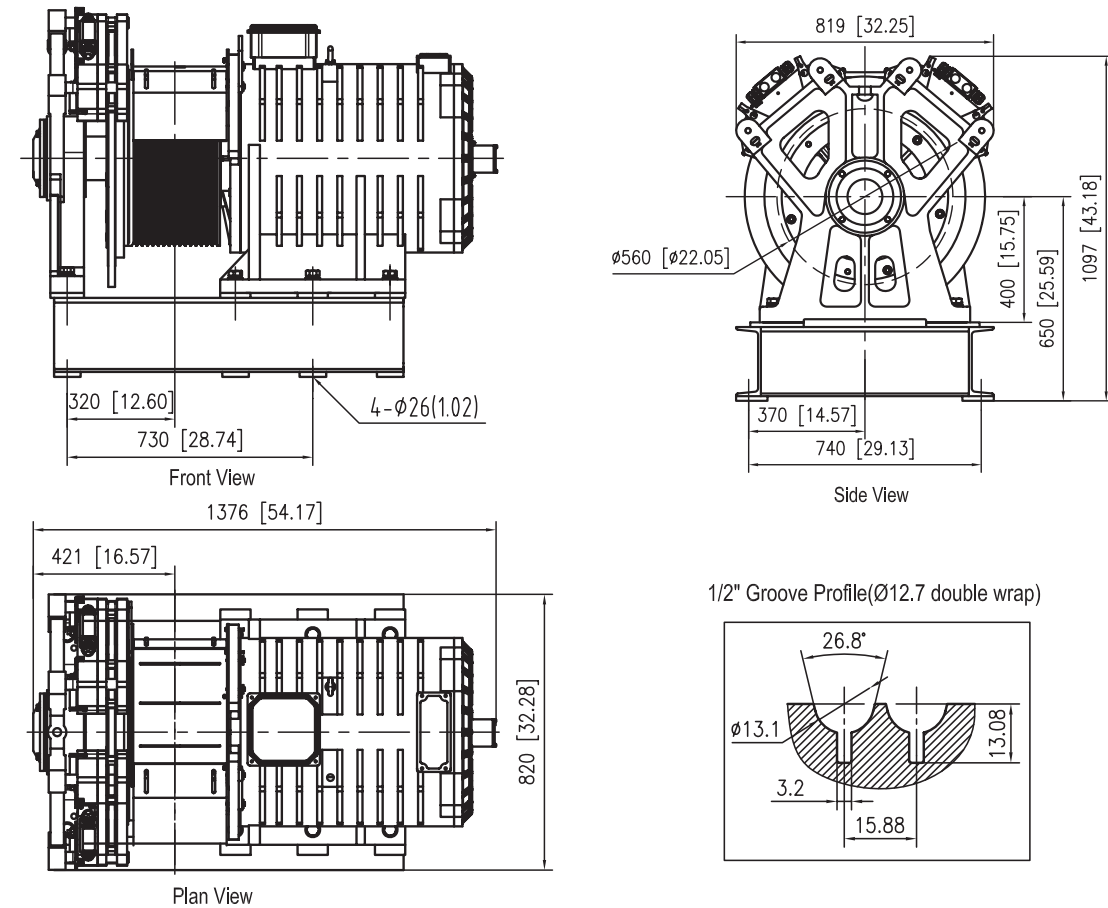

**Notes**

As shown is double wrapping, single wrapping is optional.

# HGL402A



Traction Machine	
Roping	1:1
Max Shaft Load (lbs)	45000
Weight(lbs)	4620
Sheave	16*Grooves *1/2" (DW 26.8°) *5/8" Pitch
Normal Brake	
Model	DIB360
Pick/Hold Voltage (VDC)	110/55
Pick/Hold Current (A)	2.2/1.1
Emergency Brake	
Model	DIB360
Pick/Hold Voltage (VDC)	110/55
Pick/Hold Current (A)	2.2/1.1



Machine Part No.	Rated Load (lbs)	Speed (fpm)	Sheave Diameter (in)	Power (HP)	Rated Voltage (VAC)	Rated Current (A)	Rated Frequency (Hz)	Rated Speed (Rpm)	Rated Torque (lbs.ft)
HGL402A-4035-DW	4000	350	20.47	26	325	48	10.9	65	2086
HGL402A-4050-DW	4000	500	20.47	36.9	325	64	15.5	93	2086
HGL402A-4070-DW	4000	700	20.47	52.1	325	85	21.8	131	2086
HGL402A-4080-DW	4000	800	20.47	62.1	325	100.5	24.8	149	2191

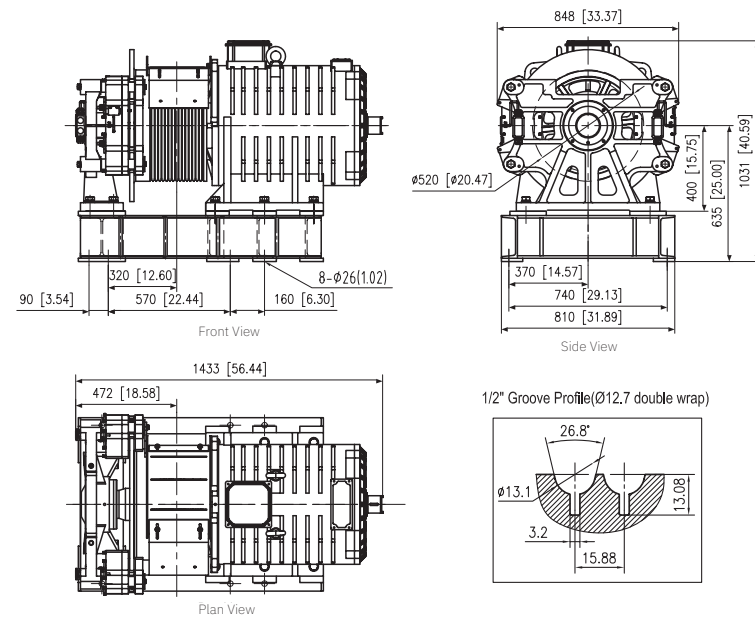

**Notes**

As shown is double wrapping, single wrapping is optional.

# HGL403-1



Traction Machine	
Roping	1:1
Max Shaft Load (lbs)	44992
Weight(lbs)	6600
Sheave	16 Grooves *5/8" (DW 21.6°) *3/4" Pitch
Normal Brake	
Model	DIB360
Pick/Hold Voltage (VDC)	110/55
Pick/Hold Current (A)	2.2/1.1
Emergency Brake	
Model	DIB360
Pick/Hold Voltage (VDC)	110/55
Pick/Hold Current (A)	2.2/1.1



Machine Part No.	Rated Load (lbs)	Speed (fpm)	Sheave Diameter (in)	Power (HP)	Rated Voltage (VAC)	Rated Current (A)	Rated Frequency (Hz)	Rated Speed (Rpm)	Rated Torque (lbs.ft)
HGL403-8050 (1:1)	4000	1000	27.56	78.7	350	127	27.8	139	2972
HGL403-8060 (1:1)	4000	1200	27.56	94	350	148	33.2	166	2972
HGL403-8070 (1:1)	4000	1400	27.56	109.8	350	178	38.8	194	2972

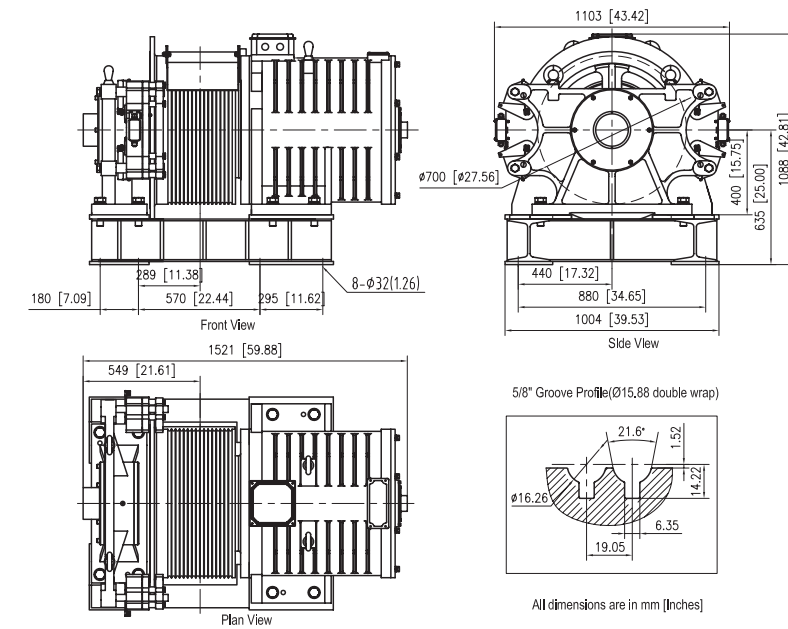

# HGL403-2



Traction Machine	
Roping	2:1
Max Shaft Load (lbs)	89984
Weight(lbs)	6600
Sheave	16 Grooves *5/8" (DW 21.6°) *3/4" Pitch
Normal Brake	
Model	DIB360
Pick/Hold Voltage (VDC)	110/55
Pick/Hold Current (A)	2.2/1.1
Emergency Brake	
Model	DIB360
Pick/Hold Voltage (VDC)	110/55
Pick/Hold Current (A)	2.2/1.1

Machine Part No.	Rated Load (lbs)	Speed (fpm)	Sheave Diameter (in)	Power (HP)	Rated Voltage (VAC)	Rated Current (A)	Rated Frequency (Hz)	Rated Speed (Rpm)	Rated Toque (lbs.ft)
HGL403-8050(2:1)	8000	500	27.56	78.7	350	127	27.8	139	2972
HGL403-8060(2:1)	8000	600	27.56	94	350	148	33.2	166	2972
HGL403-8070(2:1)	8000	700	27.56	109.8	350	178	38.8	194	2972

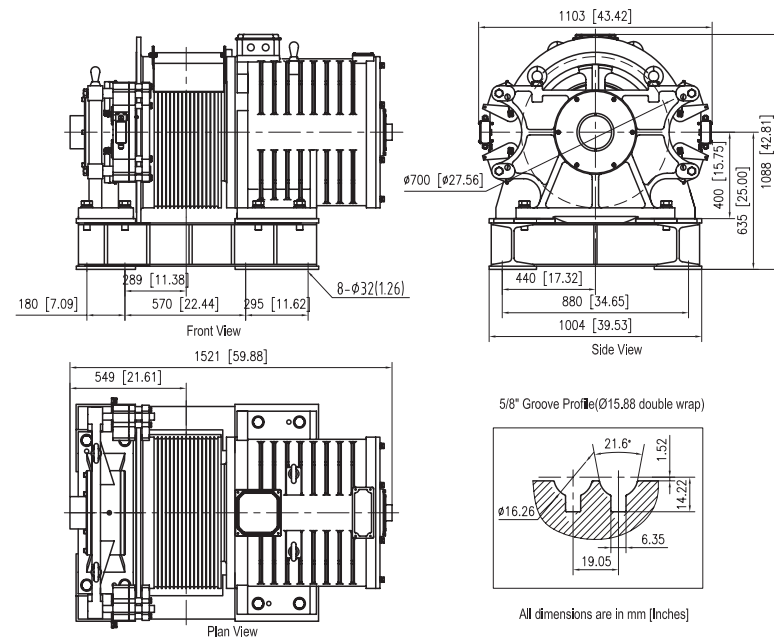

# HGL403A



Traction Machine	
Roping	1:1
Max Shaft Load (lbs)	89984
Weight(lbs)	6600
Sheave	16*Grooves *5/8"(DW 21.6°) *3/4" Pitch
Normal Brake	
Model	DIB360
Pick/Hold Voltage (VDC)	110/55
Pick/Hold Current (A)	2.2/1.1
Emergency Brake	
N/A	

Machine Part No.	Rated Load (lbs)	Speed (fpm)	Sheave Diameter (in)	Power (HP)	Rated Voltage (VAC)	Rated Current (A)	Rated Frequency (Hz)	Rated Speed (Rpm)	Rated Toque (lbs.ft)
HGL403A-5035	5000	350	25.6	34.8	350	57.5	10.6	53	3445
HGL403A-5050	5000	500	25.6	49.3	350	79	15	75	3445

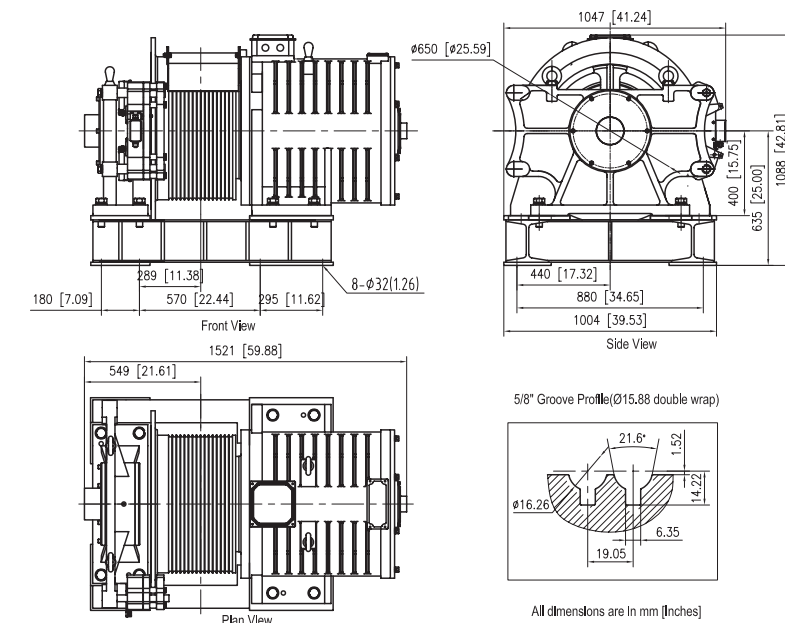

**Notes**

As shown is double wrapping, single wrapping is optional.



1.866.900.3727  
info@delcoelevator.com  
www.delcoelevator.com



**CANADA**  
#205-3765 E 1st Avenue  
Burnaby, BC V5C 3V8

**USA**  
2302 West Valley Highway North,  
Suite 300, Auburn, WA 98001

**www.delcoelevator.com**  
info@delcoelevator.com | 1-866-900-3727

February 2024