

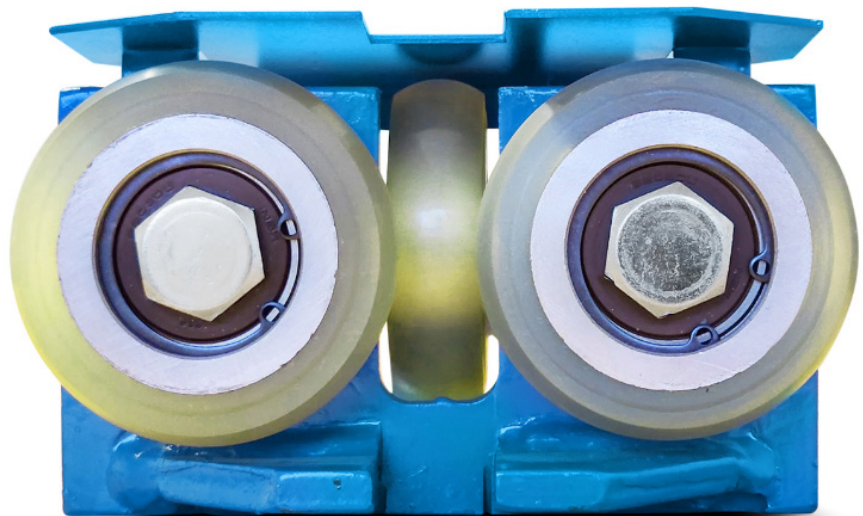

3" SPRING FREE ROLLER GUIDE ASSEMBLY



3" SPRING FREE

With Dust Cover

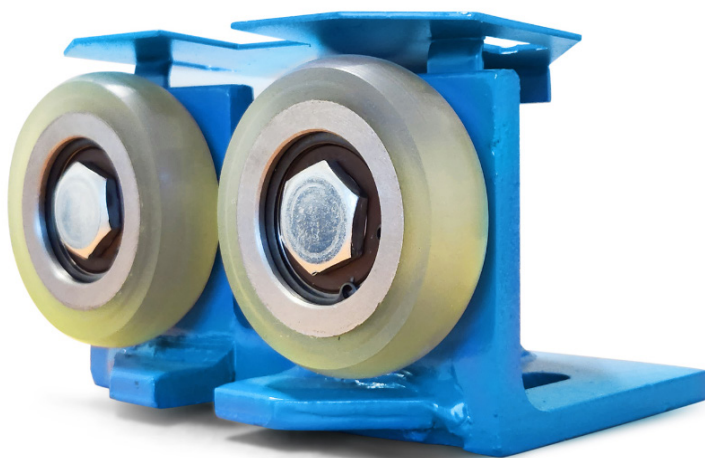

Easy Installation

The Delco 3" Spring Free model is normally used in counterweight applications. Its best suited for passenger and hospital elevators that require speeds up to 700 fpm (3.5 m/s) and high capacities up to 6613 Lbs (3000 Kg).

These roller guide assemblies most often work in conjunction with all Delco Roller Guide Assemblies.

Features

One key advantage of the spring free model is the extra simple installation as no spring adjustments are required.

This model comes with a dustcover and slotted holes in the base for field misalignment.

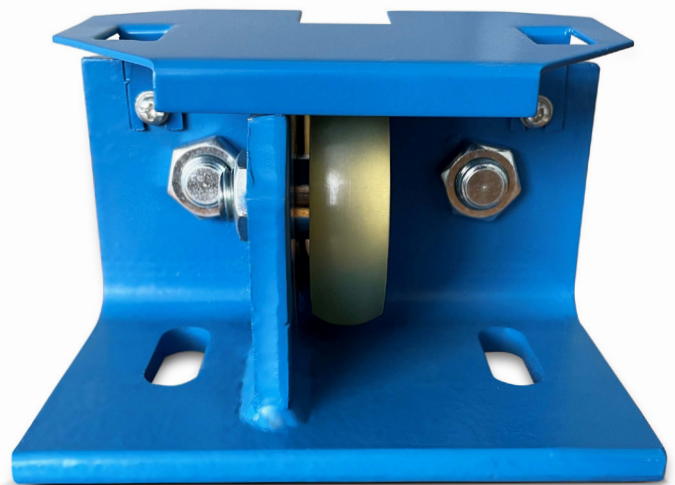
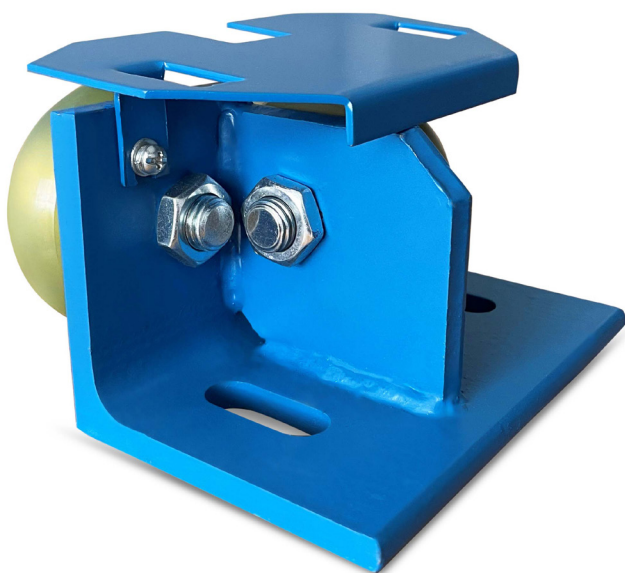

3" SPRING FREE

Specifications

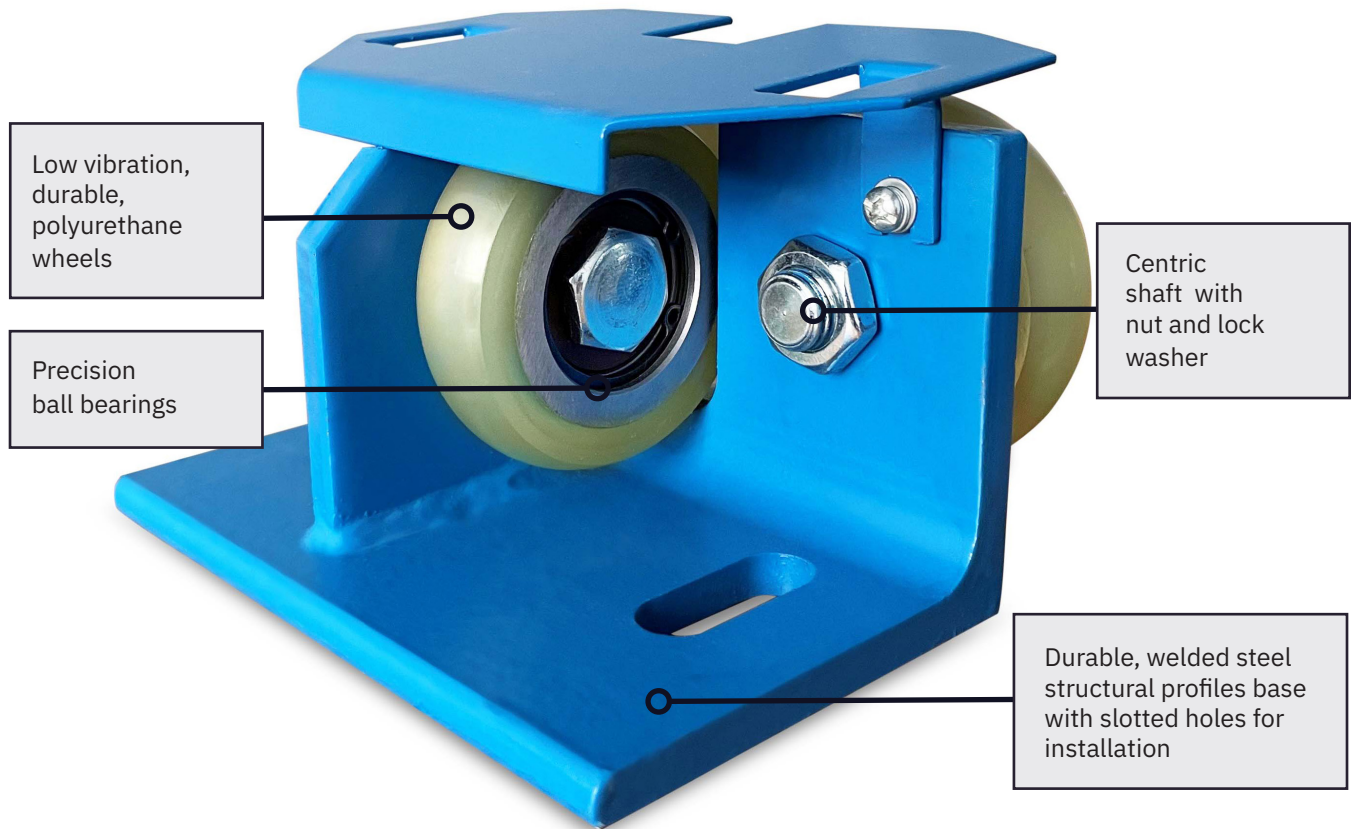

C-08-0815

Capacity	up to 6613 Lbs (3000 Kg)
Speed	CWT Side: up to 689 fpm (3.5m/s)
Guide Rail Width	10mm (27/64"), 16mm (5/8")
Roller Diameter	3" (76mm)
Roller Material	Polyurethane
Roller Hardness	80±3 (Durometer Shore A)
Structural Frame	Structural welded profiles
Ball Bearings	NSK 6203DU
Weight	9 Lbs
Delco SKU	C-08-0815

3" SPRING FREE

Installation Guide

Note: The following instructions are a guideline only. The installation process may need to be adjusted depending on the specific project and variable pre-existing conditions. Installations must be performed by a certified mechanic.

1. Schematic diagram of the installation of the counterweight roller guide shoe

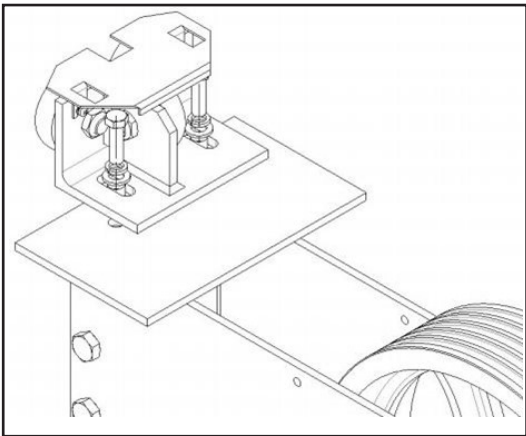

Figure 1: Installation of counterweight roller guide shoe

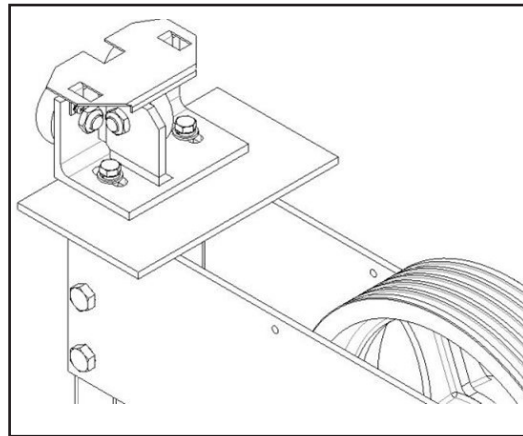

Figure 2: Completed installation of counterweight roller guide shoe

2. Installation and commissioning of counterweight guide shoe

- Counterweight roller guide shoes are mounted on the upper and lower beams of the counterweight frame.
- During installation, select the mounting holes on the base plate of the guide shoe according to the illustration, and connect it with the transition plate of the upper and lower beams of the counterweight frame with M16×50 hexagonal bolts (with spring pads and flat pads).
- During installation, it is required that the center of upper and lower guide shoes and the center of counterweight rail are on the same vertical line, if the counterweight frame is equipped with counterweight safety gear, it should be required that the center of upper and lower guide shoes and the center of counterweight safety gear are on the same vertical line. The roller guide shoe should be installed in a level position. Under normal conditions, the factory has completed the adjustment and positioning according to the rail type of the order requirements before delivery from the factory.

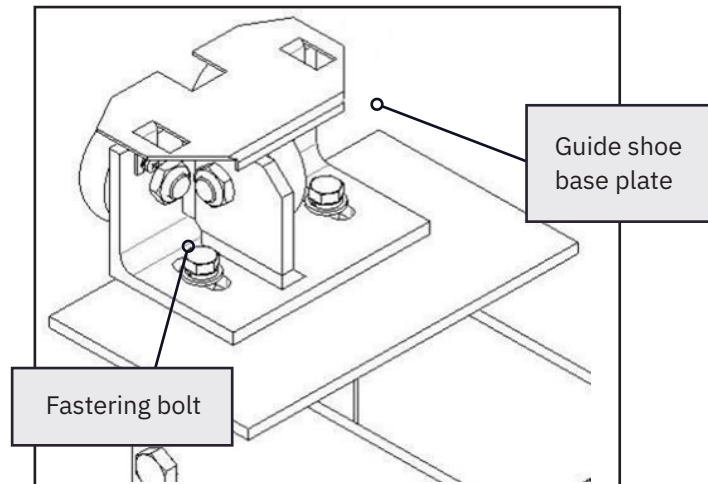

Figure 3: Counterweight guide shoe installation & commissioning

3. Use of roller guide shoe

- In the course of use, the roller rubber layer wearing should be checked, uneven surface wearing may indicate that the pivot has worn out. In addition, check signs of damage of other parts, if the above conditions are found, they should be replaced in time.
- The surface of the guide rail is not allowed to be coated with oil to prevent the roller from slipping and breaking, and the guide shoe can only run on the dry guide rail. The surface material of the roller is polyurethane, with a life time of 3 years under normal use;

Important!

- Do not oil the guide rail. Oiling will cause slippage.
- Check the roller guide assembly regularly after correct installation to ensure that it is running evenly and smoothly.
- Be sure to replace the guide wheels as soon as any uneven abrasion on the roller surface or cracks are observed on the springs.

3" SPRING FREE

Diagram Top View

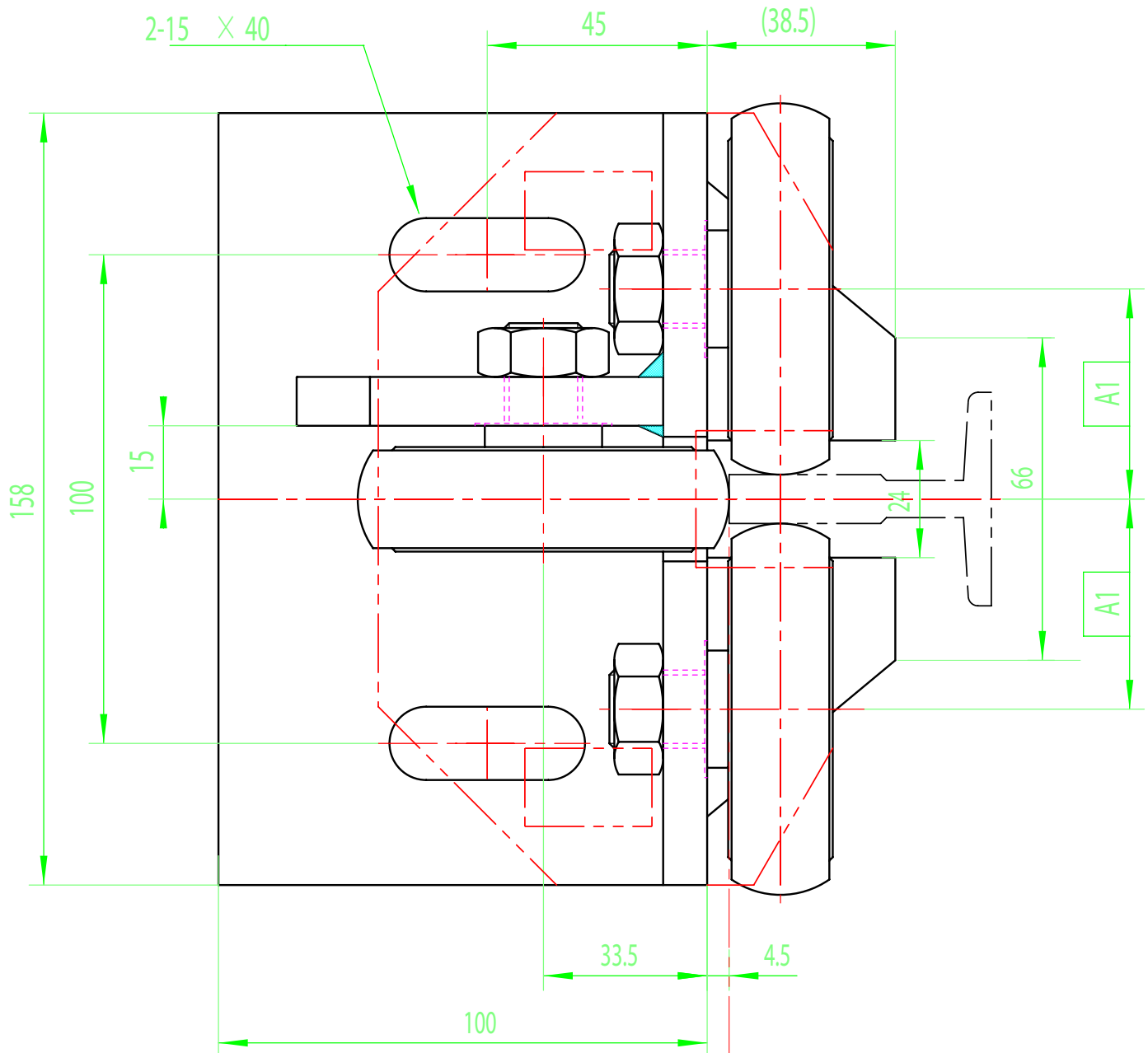

3" SPRING FREE

Diagram Baseplate View

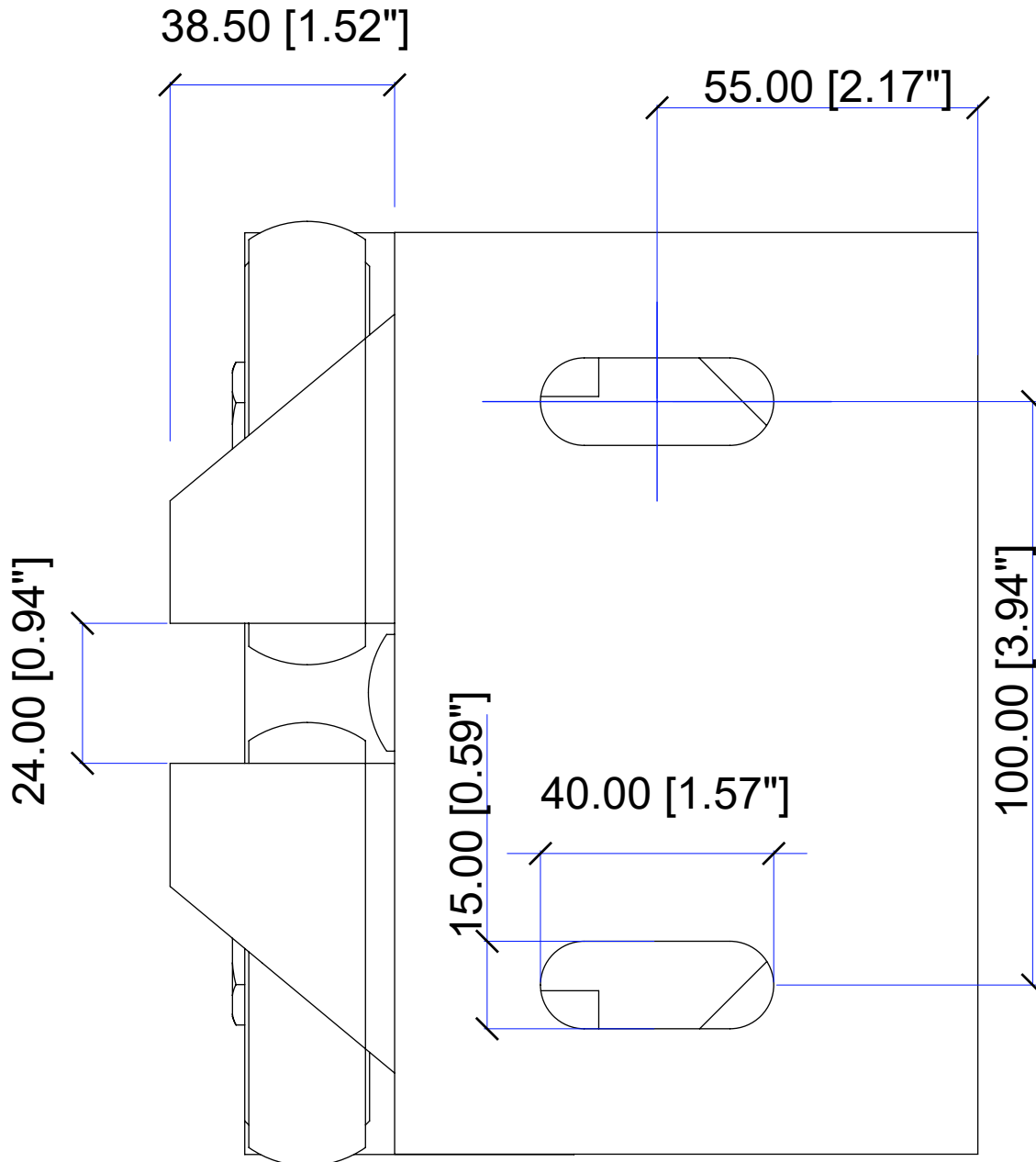

3" SPRING FREE

Diagram Front View

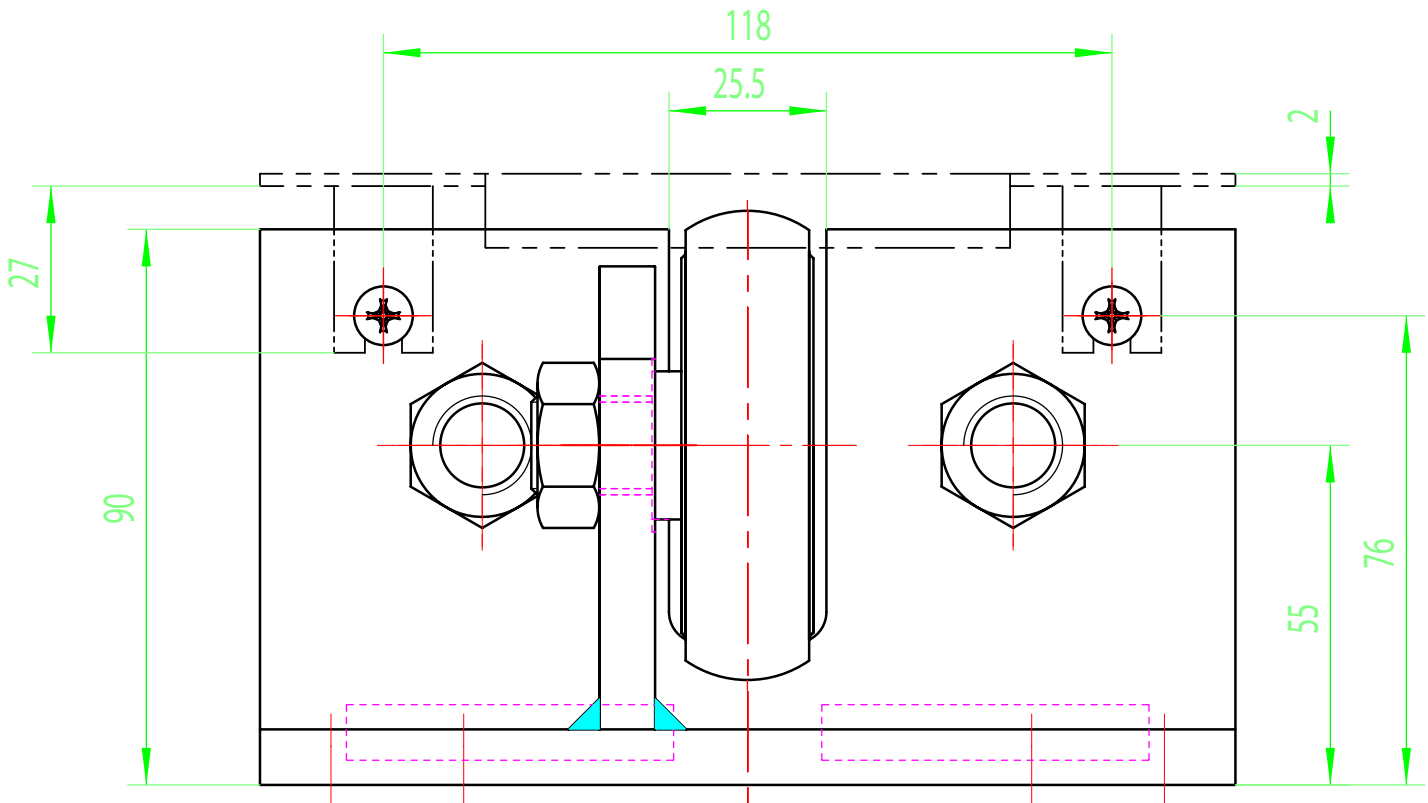

Roller Guide Assembly Template

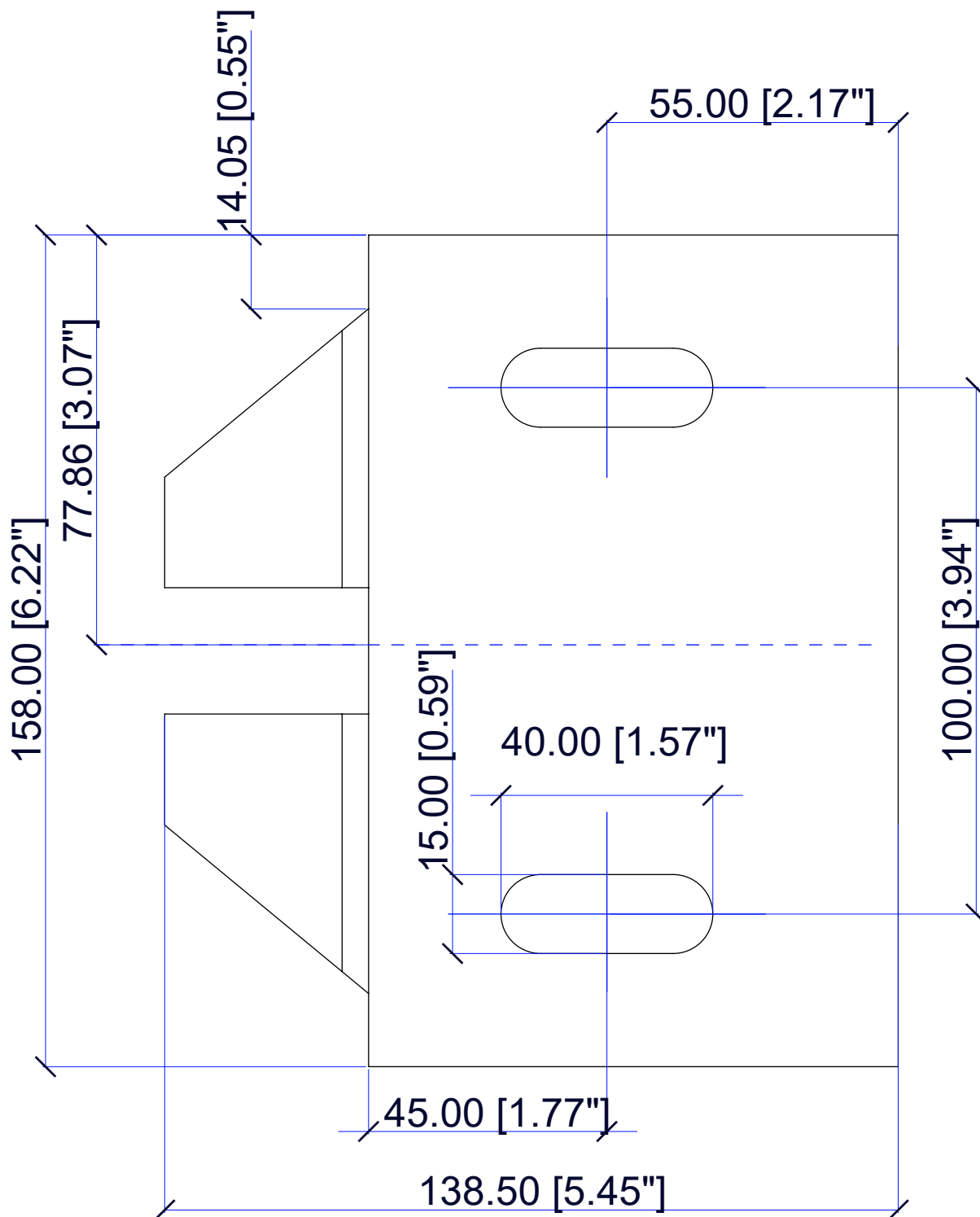

3" SPRING FREE

Exploded View

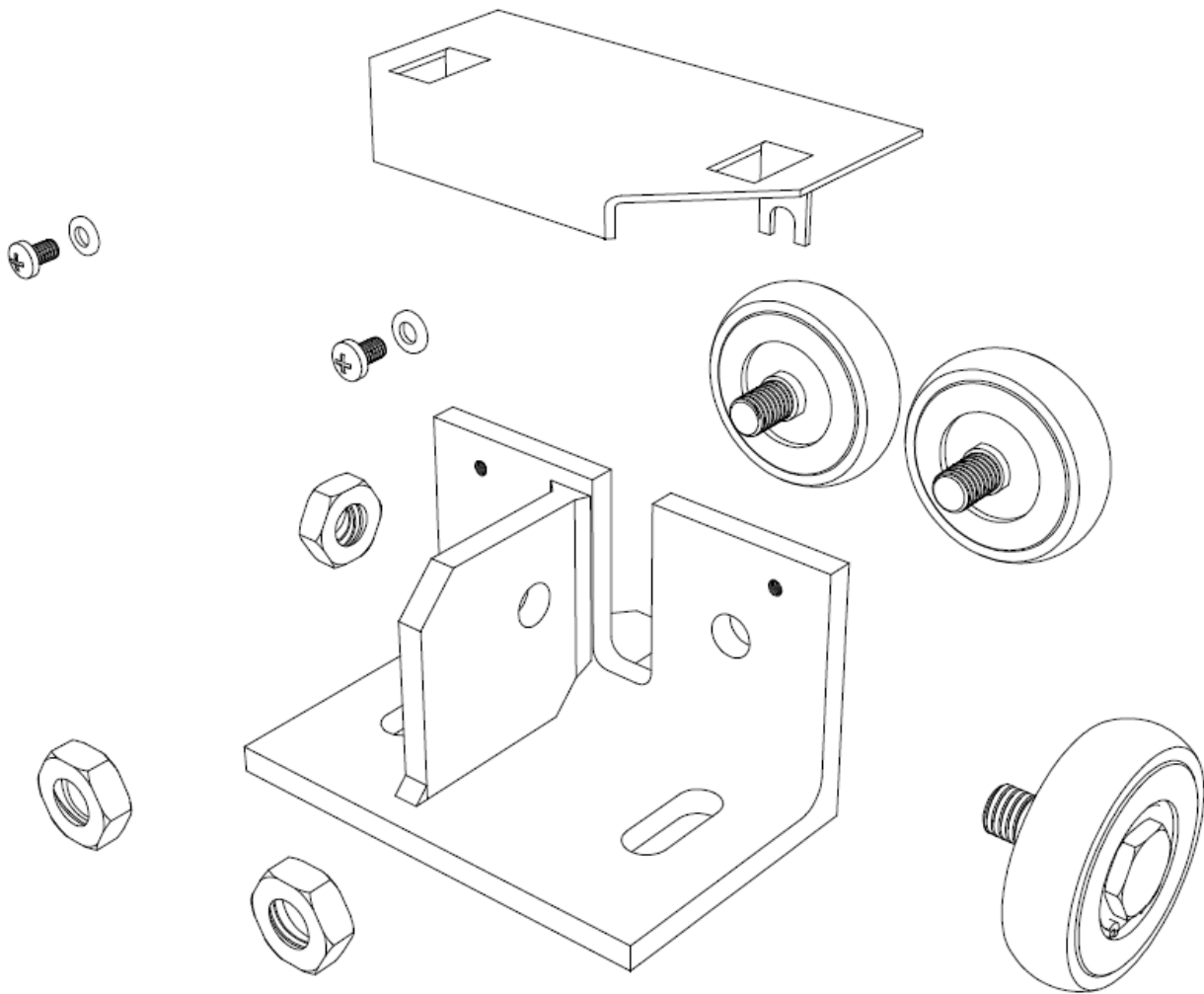

ROLLER GUIDES

9 Models | up to 3000 KG | up to 2000 fpm

Proven

With over 17,000 Delco Roller Guide Assemblies installed and running every day, our products are being relied on by hundreds of elevator contractors.

CAPACITY: 0 – 6615 LBS (3000 KG)

SPEED: 0 – 2000 FPM (6.0M/S)

Meeting the requirements for over 90% of elevator installations, Delco offers 9 different RGA models. Low-rise, mid-rise and high-rise buildings throughout North America use Delco Roller Guides.

Easy to install and easy to maintain, Delco Roller Guides are manufactured with high precision, using the best materials, to provide many years of worry-free operation in many different elevator installation situations.

3" to 10" RGA

0-1200 fpm

Delco's 3" to 10" rollers are made from Polyurethane, which has a high compression strength and doesn't create flat spots, ensuring reliable operation for many years. The cast iron frames and heavy duty hardware ensure a long life in all elevator hoistway environments. These roller guides are made with NSK ball bearings manufactured in Japan, recognized world wide as the most reliable, high performance bearings.

12" RGA

Up to 2000 fpm

Delco's 12" rollers are made from vulcanized rubber for resilience and durability. The 12" RGA frame is constructed from high-intensity aluminum alloy providing robust structural support for stability and long-lasting performance. Delco's 12" RGA utilizes high performance, brand CW: type 6205, ball bearings.

Product Line

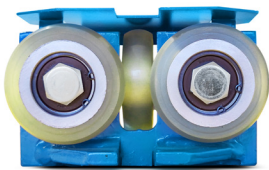

3" SPRING FREE
C-08-0815 (16 mm)
C-08-0817 (10 mm)

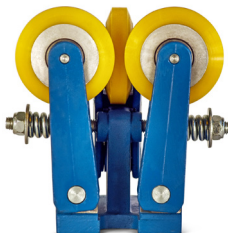

3¼" STANDARD
C-08-0810

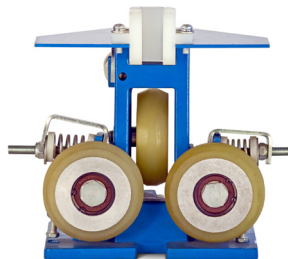

3¼" HIGH SPEED
C-08-0807

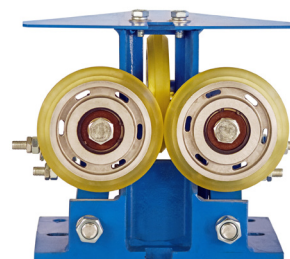

5" STANDARD
C-08-0805

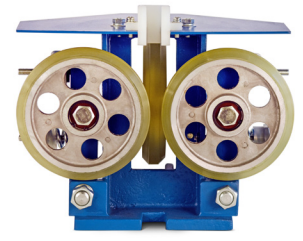

6" STANDARD
C-08-0804

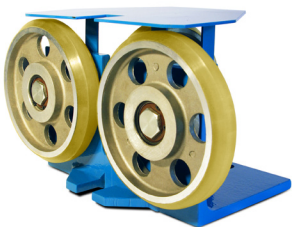

6" SPRING FREE
C-08-0806



7⅞" STANDARD
C-08-0808

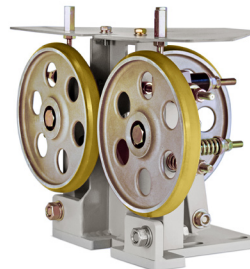

10" HIGH SPEED
C-08-0803



12" HIGH SPEED
C-08-0820-G19

SELECTION GUIDE

Pas-senger Elevator	0-500fpm (0-2.5m/s)		600-800fpm (3.0-4.0m/s)		1000-1200fpm (5.0-6.0m/s)	
	Delco Car	Delco CWT	Delco Car	Delco CWT	Delco Car	Delco CWT
<3000lbs	C-08-0805 C-08-0804	C-08-0810 C-08-0807 C-08-0815	C-08-0804	C-08-0807	C-08-0803	N/A
3500lbs (1600kg)	C-08-0805 C-08-0804	C-08-0810 C-08-0807 C-08-0815	C-08-0804	C-08-0807	C-08-0803	N/A
4000lbs (1800kg)	C-08-0804	C-08-0810 C-08-0807 C-08-0806	C-08-0804	C-08-0807	C-08-0803	N/A
4500lbs (2050kg)	C-08-0808	C-08-0806	C-08-0808	C-08-0806	C-08-0803	N/A
5000lbs (2300kg)	C-08-0808	C-08-0806	C-08-0808	C-08-0806	C-08-0803	N/A
6000lbs (2700kg)	C-08-0808	C-08-0806	C-08-0808	C-08-0806	C-08-0803	N/A
7000lbs (3200kg)	C-08-0803	C-08-0806	C-08-0803	C-08-0806	N/A	N/A

Hospital Elevator	0-250fpm (0-1.25m/s)		300-500fpm (1.5-2.5m/s)		600-800fpm (3.0-4.0m/s)		1000-1200fpm (5.0-6.0m/s)		1000-2000fpm (5.0-10m/s)	
	Car	CWT	Car	CWT	Car	CWT	Car		Car	
<3000lbs	C-08-0805 C-08-0804	C-08-0810 C-08-0807 C-08-0815	C-08-0805 C-08-0804	C-08-0810 C-08-0807 C-08-0815	C-08-0804	C-08-0807 C-08-0815	C-08-0803	N/A	C-08-0820-G19	N/A
3500lbs (1600kg)	C-08-0805 C-08-0804	C-08-0810 C-08-0807 C-08-0815	C-08-0805 C-08-0804	C-08-0810 C-08-0807 C-08-0815	C-08-0804	C-08-0807	C-08-0803	N/A	C-08-0820-G19	N/A
4000lbs (1800kg)	C-08-0804	C-08-0806	C-08-0804	C-08-0806	C-08-0804	C-08-0807	C-08-0803	N/A	C-08-0820-G19	N/A
4500lbs (2050kg)	C-08-0808	C-08-0806	C-08-0808	C-08-0806	C-08-0808	C-08-0806	N/A	N/A	N/A	N/A

Freight Elevator

For freight elevator applications the Roller Guide Assembly selection will be based on the number of guide rails. For applications with 2 guide rails, refer to the Passenger Elevator chart above. For applications with 4 or more guide rails, please contact us.

Important!

Please note that this table is only to be used as a guideline. Roller Guide Assembly selection must take many other criteria into consideration that can't be accounted for in this chart. Please contact us for selection assistance.