

Delco

ELEVATOR PRODUCTS

IN STOCK
NON-PROPRIETARY
PROVEN & COMPETITIVE

HAIDERDRIVE



D·MRL
PACKAGE

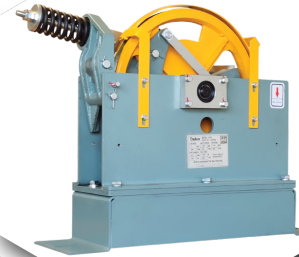

OLEO
INTERNATIONAL

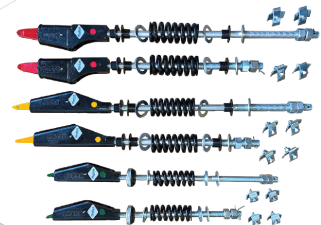
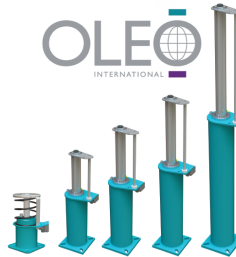

www.delcoelevator.com
info@delcoelevator.com | 1-866-900-3727

CONTENTS

WELCOME	3
Product Line	3
How to Order	3
HAIDER DRIVE: ELEVATOR TRACTION MACHINES	4
ECO Gearless	5
PRO Gearless	6
MRL	7
Geared	8
Basement	9
NEW CONSTRUCTION PACKAGES	10
MOD PACKAGE	14
WHOLESALE	15
GOVERNOR & TENSION DEVICE	16
Standard	16
Self Resetting	17
Tension Device	18
ROLLER GUIDE ASSEMBLY	19
3" Spring Free	20
3¼" Standard	20
3¼" High Speed	21
5" Standard	21
6" Standard	22
6" Spring Free	22
7⅞" Standard	23
10" High Speed	23
OLEO OIL BUFFERS	24
LSB, MLB Series	24
LB Series	25
SHACKLES	26
BARRICADES	27
CARTOP & SWITCHES	33
Cartop Station	33
Limit Switch	34
Safety Switch	34
Run Station	35
E-Stop	35
WECO DOOR DETECTORS	36
DOOR CLOSERS HD	37
BOARDS & PARTS	38
ABOUT DELCO	39

WELCOME!



PRODUCT LINE



In Stock, Non-Proprietary, Proven & Competitive

Product Line:

- Elevator Traction Machines
- New Construction Packages
- Governors
- Roller Guide Assemblies
- Oleo Oil Buffers
- Shackles
- Safety Barricades
- Cartop and Run Stations
- Limit Switches
- Door Detectors
- Door Closers

The Delco Difference

- **In Stock:** We keep our inventory stocked to make sure that customers receive what they need, when they need it.
- **Non-Proprietary:** Delco's products are universal – perfect for modernizations.
- **24 Hours:** From when you place your order until it's picked, packed and shipped out the door.
- **Proven Products:** Delco manufactures and distributes products that are tried, tested and proven in the field.
- **Compliant:** Delco products and equipment meet all elevator industry compliance and certification standards.
- **Value for Money:** In a highly competitive marketplace, Delco provides the best quality elevator equipment at the lowest possible prices.
- **Personal, Knowledgeable Staff and Service:** Always on hand to assist you with your unique requirements!
- **US and Canadian Locations:** No hassles, no border crossings, no tariffs, no waits... your order will be fulfilled and shipped in country.

HOW TO ORDER

Delco services elevator contractors and OEMs in Canada, the Caribbean and the US, including Puerto Rico and Hawaii.

OFFICE & WAREHOUSE CANADA
#205-3765 1st Avenue
Burnaby, BC V5C 3V8

WAREHOUSE USA
2302 West Valley Highway North, Suite 300
Auburn, WA 98001

Phone: 1.604.904.3727 - CAN/USA
Toll Free: 1.866.900.3727
Email: info@delcoelevator.com
www.delcoelevator.com

We look forward to welcoming you to our family of customers and friends.

We'd love to hear from you and give you a quote on your next project.
Call, email or visit us today!

HAIDERDRIVE

Introducing
The Ultimate Combination Of
Quality & Affordability

HAIDER DRIVE is a full line of **CSA approved elevator machines**
for modernization & new construction

Eco Gearless

Pro Gearless

MRL

Geared

Basement

CSA Approved

Full Line

High Quality

Best Price

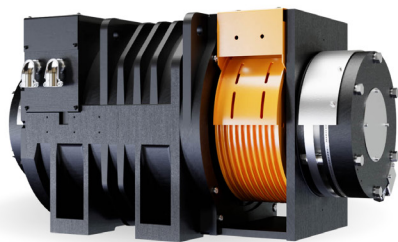

Why Haider Drive?



High Quality Machines

Enjoy easy installation & reliable quality.
The full line of HAIDER machines
is CSA approved.



Affordability

Best price on the market.
Send us a quote request
today!



Support

Our experienced team will
guide you and will make the
process easy for you.

ECO Gearless

HGL Series

HGL Series (1:1 roping)			
	Speed		
Capacity (lbs)	200	350	500
2500	HGL292A (508mm)		
3000			
3500	HGL292 (410mm)		
4500	HGL320		

HGL Series (2:1 roping)		
	Speed	
Capacity (lbs)	500	700
5000	HGL292A (508mm)	

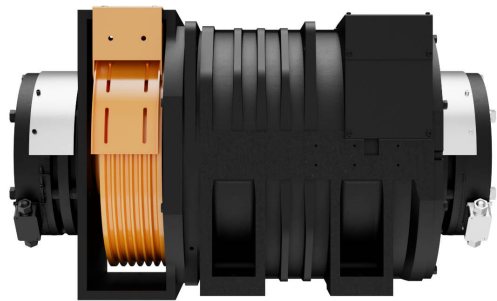

HGL292A

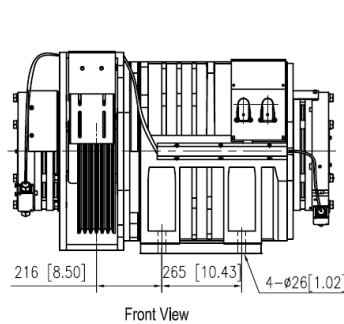

Front View

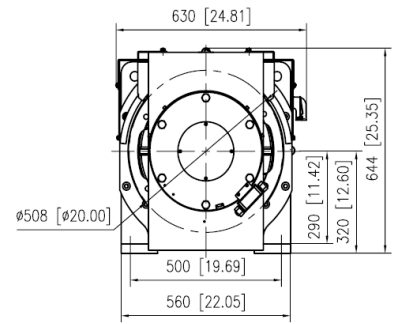

Side View

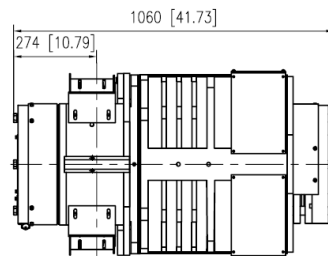

Plan View

1/2" Groove Profile (Vh 40°)

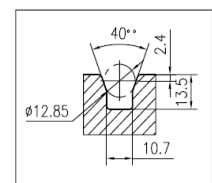

All dimensions are in mm [Inches]

PRO Gearless

HGL Series

HGL Series (2:1 roping)				
	Speed			
Capacity (lbs)	500	600	700	800
3500	HGL401			
5000	HGL402			
8000	HGL403			

HGL Series (1:1 roping)							
	Speed						
Capacity (lbs)	350	500	700	800	1000	1200	1400
3500	HGL402			HGL402A	HGL403		
4000	HGL402A						
5000	HGL403A						

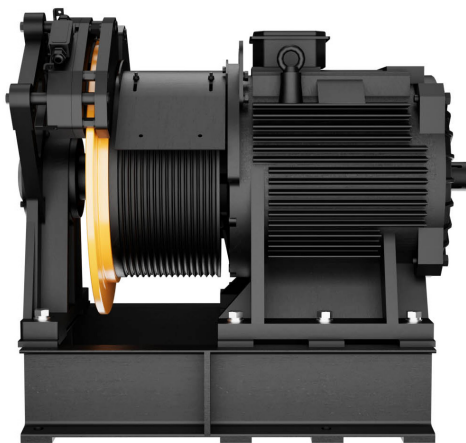

HGL401

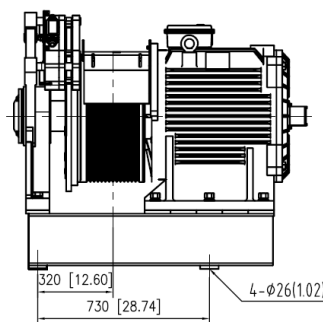

Front View

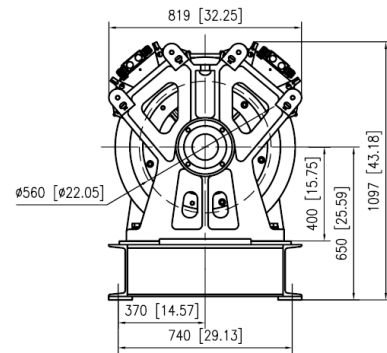

Side View

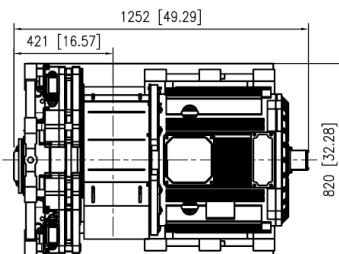

Plan View

1/2" Groove Profile(Ø12.7 double wrap)

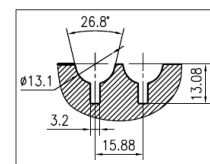

All dimensions are in mm Inches

Machine Roomless

HGL Series

HGL Series - 8 MM Rope (2 : 1 roping)						
	Speed					
Capacity (lbs)	100	150	200	250	300	350
2500	HGL280		HGL332			
	HGL205F					
3500	HGL333					
	HGL205G					

HGL Series - 10 MM Rope (2 : 1 roping)						
	Speed					
Capacity (lbs)	200	300	350	400	500	
2500	HGL332					
3500	HGL334					
	HGL334	HGL334			HGL290	
		HGL290				
5000	HGL290					

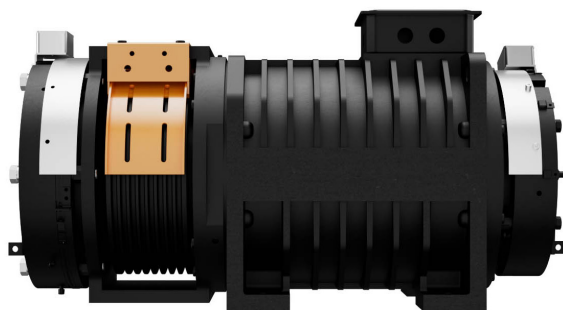

HGL205F

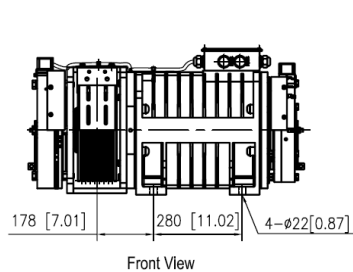

Front View

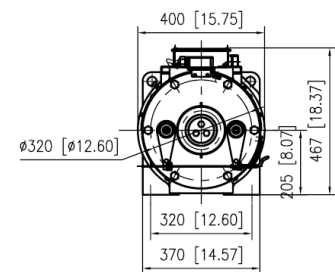

Side View

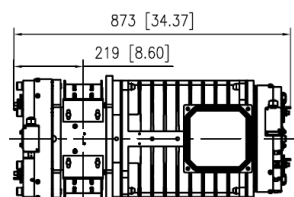

Plan View

8mm Groove Profile(Vh 45°)

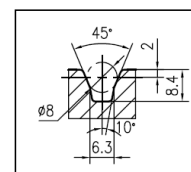

All dimensions are in mm [Inches]

Overhead Geared

HGD Series

HGD Series (1:1 roping)											
Capacity (lbs)	50	100	150	200	250	300	350	400	450	500	
1500	HGD200							HGD245	HGD245D		
1760											
2000	HGD245										
2500											
3000	HGD245D								HGD320		
3500											
4000	HGD320A										
4500											
5000											
5500											
6000	HGD320										
7000	HGD320				HGD410						
8000	HGD410										
9000	HGD410										
10000											
12000	HGD410										

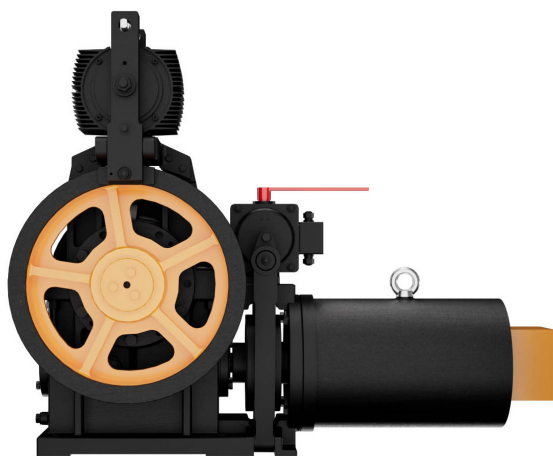

HGD200

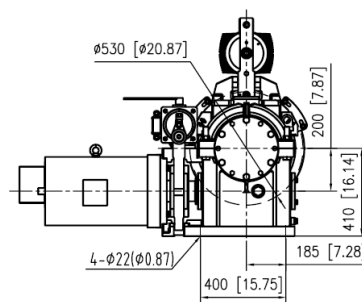

Front View

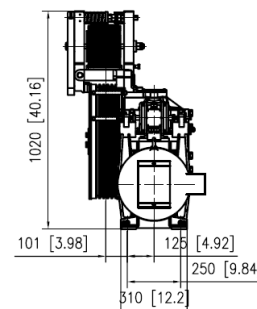

Side View

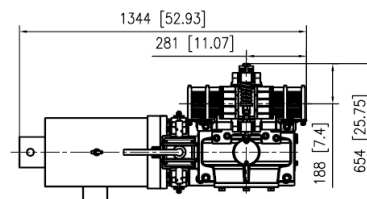

Plan View

1/2" Groove Profile(U30°~96.5°)

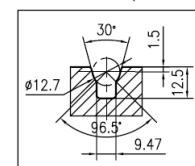

All dimensions are in mm [Inches]

Basement

HGD Series

HGD Series (1:1 roping)									
Capacity (lbs)	50	100	150	200	250	300	350	400	450
1500	HGD1B								HGD320B
1760									
2000									
2500									
3000	HGD320B								
3500									
4000									
4500									
5000									
5500									
6000									

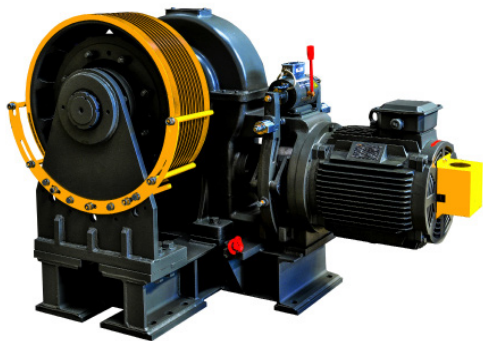

HGD320B - SC

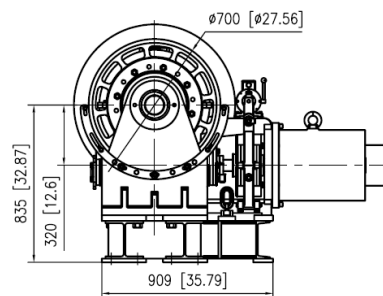

Front View

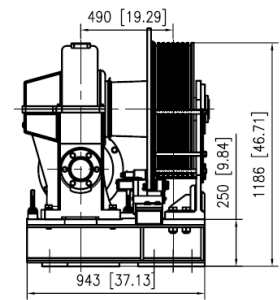

Side View

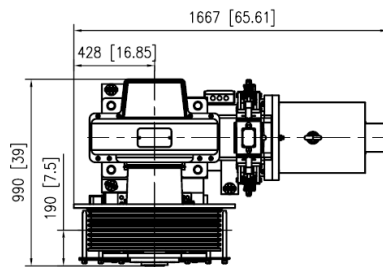

Plan View

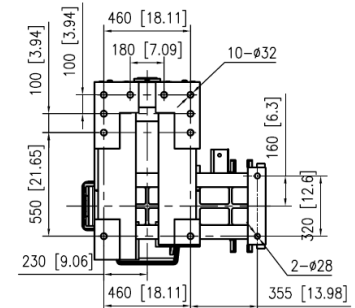

Bottom View

NEW CONSTRUCTION PACKAGES

Machine Roomless	Machine Room	Hydraulic
------------------	--------------	-----------

Why Delco?



Non-Proprietary

Compatible with the controller of your choice.
Compatible with the fixture of your choice.



After-Sale Support

Our team will be there with you even after the sale is complete with anything you might need.



Expert Team

Our experienced team will guide you and will make the process easier for you.



One-Stop Shop

Purchasing convenience: one order, one package to track and all parts in one place ready to install.

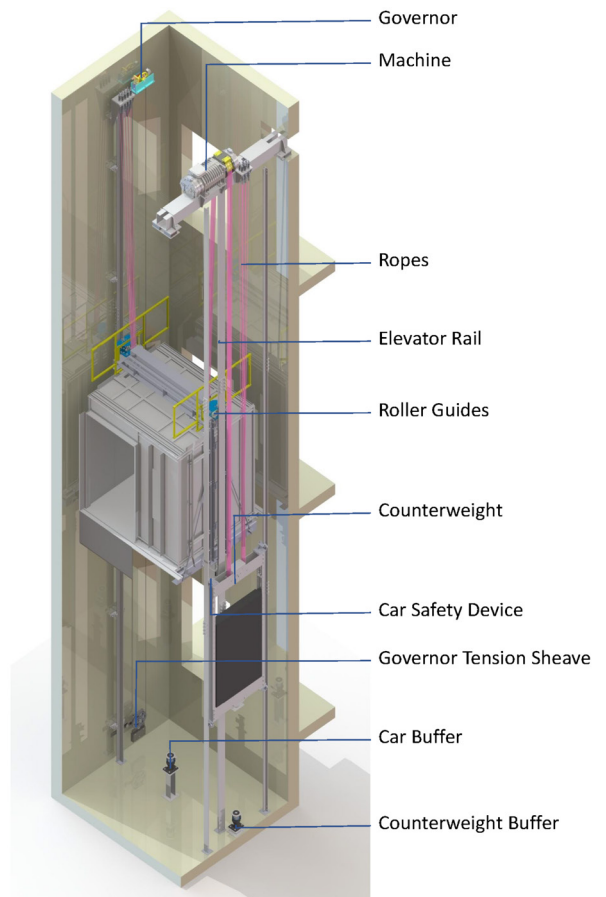

MOST POPULAR:

D·MRL

P A C K A G E

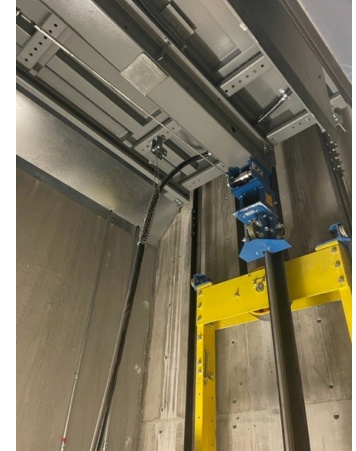
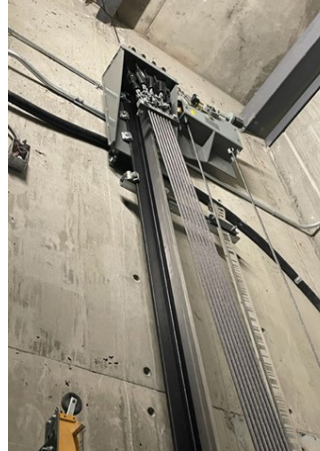

Your Vision, Our Creation: [Explore Custom Jobs Today!](#)

Features:

- Rail-mounted or beam-mounted layout
- Pancake or sausage style machine
- Max. Rise = 260'
- Cab height up to 10'
- Available for seismic zones
- Wide Selection of cab interior finishes





Included Items:

1	Guide Rail Sub System
	Rail Bracket - CAR/CWT
	Guide Rail w Fish Plate & Hardware - CAR/CWT
2	Machine Sub System
	Traction Machine
	Machine Support and Hitch
3	Structure and Suspension Sub System
	Sling, Platform, Isolation and Rail Lock
	Frame - CAR/CWT
	Sheave - CAR/CWT
	Wire Rope - Hoist
	Wedge Sockets
	Compensation Rope
	Compensation Anti Sway Device





4	Door and Entrance Sub System
	Door Operator
	Landing Header Assembly
	Entrance, Incl. Car and Landing Sill.
5	Hoistway Component Sub System
	Governor
	Governor Tension Sheave
	Governor Rope
	Safety Gear with Retainer
	Oil Buffer - CAR/CWT
	Roller Guides with Brackets - CAR/CWT
	Pit Ladder
6	Cab Sub System
	Top Rail, Car Door, Interior (laminate, floor, ceiling)

NEW CONSTRUCTION







-  **Ceiling:**
Hairline SUS304
-  **Trim Panel:**
Wilsonart S104-HD60
1.0 mm on 13 mm wood core
-  **Handrail:**
Hairline SUS304
-  **Floor:**
PVC (black)
-  **Door:**
Hairline SUS304







-  **Ceiling:**
Hairline SUS304
-  **Trim Panel:**
Wilsonart W2802-HD60
1.0 mm on 13 mm wood core
-  **Handrail:**
Hairline SUS304
-  **Floor:**
PVC (black)
-  **Door:**
Hairline SUS304



-  **Ceiling:**
Hairline SUS304
-  **Trim Panel:**
Wilsonart 4157-HD60
1.0 mm on 13 mm wood core
-  **Handrail:**
Hairline SUS304
-  **Floor:**
PVC (black)
-  **Door:**
Hairline SUS304

NEW CONSTRUCTION



-  Ceiling:
Hairline SUS304
-  Trim Panel:
Wilsonart 4280-HD60
1.0 mm on 13 mm wood core
-  Handrail:
Hairline SUS304
-  Floor:
PVC (black)
-  Door:
Hairline SUS304

COMING
SOON!

Ask us about our new :

D • HYDRO P A C K A G E

Holeless Roped

Holeless With Twin
Jacks

In-Ground

One Stop Shop - Reliable Performance - Great Lead Time

MOD PACKAGE

- EASY
- ONE STOP
- COMPETITIVE
- IN STOCK

Save Up To \$1,000 Per Car



Machines

Select your machine:

- Geared
- Gearless
- MRL



Components

Add components:

- Governor
- RGA
- Shackles
- Oil Buffer
- Cartop Station
- Door Closers
- Barricades
- Door Detectors



Benefits

Enjoy the benefits:

- **10% OFF all components**
- Shipping to your door
- No tariffs
- 24-hour dispatch on components
- Customer support

Why Delco?

- We have been supplying elevator contractors with modernization products for over 30 years.
- We don't just supply products, we make the process as simple as possible and we are there to make sure that you receive what you need, when you need it and where you need it.

Our MOD Service is second to none

- When you order an elevator mod package from Delco, we work with you to make sure that you receive all the products when and where you need them.
- We will coordinate shipping and delivery of machines and components to the site or to your warehouse and we will work with you through the entire process from product selection to delivery scheduling.

NEW!

Delco Offers Wholesale Discounts

Everything you love about Delco components is now available to meet your wholesale needs!

Save time and money when you order in bulk.

All of our products are available in a variety of wholesale quantities, from shackles to roller guides to barricades. Wholesale ordering is also eco-friendlier as both packaging and shipping pollution is reduced.

Take advantage of Delco's wholesale component discounts and enjoy these benefits:

- Streamline purchasing.
- Get quantity discounts.
- Choose your shipping options.
- Have stock on hand.
- Simplify logistics.
- Save on shipping.



Products For Wholesale:

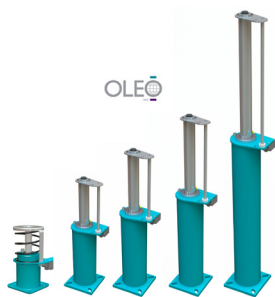

Oleo Oil Buffers



Shackles



Self-Resetting Governor

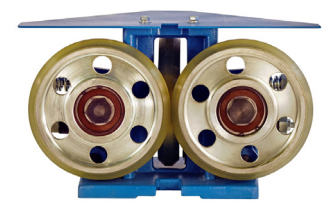

Full Line of RGAs



Tension Device



Giovenzana Products



Standard Governor



Barricades

STANDARD

Standard Overspeed Governor

All models are code compliant, come with rope retainer, safety cover and base support as well as a CSA approved limit switch.



Safety cover included

- ASME A17.1 and EN81-1
- CSA approved limit switch
- Tested, preset and sealed at factory
- Overspeed switch
- Rope retainer, full guard and base support
- Live shaft for adapting encoder is available
- Encoder mounting flex included
- Sheave diameter: 305mm/12"
- Rope type: 8 or 9.5mm 8 x S(19) / 3/8"
- Max. pull through: up to 400lbs
- Shipping weight: 47kg/105lb



Standard Overspeed Governor Tripping Speed Chart

Speed	100 fpm 0.64 M/S	150 fpm 0.76 M/S	200 fpm 1.02 M/S	250 fpm 1.27 M/S	300 fpm 1.52 M/S	350 fpm 1.75 M/S	400 fpm 2.0 M/S	500 fpm 2.54 M/S
Max Overspeed Switch Setting	158 fpm 0.8 M/S	189 fpm 0.96 M/S	252 fpm 1.28 M/S	303 fpm 1.54 M/S	353 fpm 1.79 M/S	407 fpm 2.07 M/S	459 fpm 2.33 M/S	563 fpm 2.86 M/S
Max Tripping Speed	175 fpm 0.89 M/S	210 fpm 1.06 M/S	280 fpm 1.42 M/S	337 fpm 1.71 M/S	395 fpm 2.01 M/S	452 fpm 2.3 M/S	510 fpm 2.59 M/S	625 fpm 3.18 M/S
Delco SKU	C-12-3100	C-12-3150	C-12-3200	C-12-3250	C-12-3300	C-12-3350	C-12-3400	C-12-3500

SELF RESETTING

Self Resetting Overspeed Governor

All models come with a safety cover as well as a CSA approved limit switch. The self-resetting overspeed governor has a live shaft option and a pull through of 1200lbs.

This governor has a remote trip and self-resetting function. It can be remotely reset, perfect for MRL (machine roomless) or basement traction installations or any limited access installation.

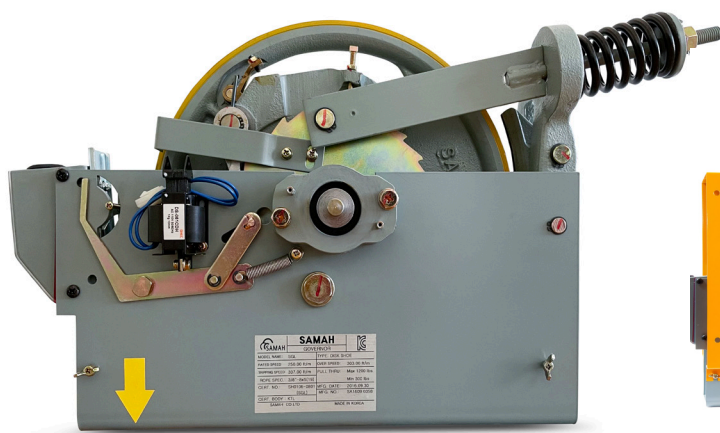

Safety cover included

- Built to meet ASME A17.1 and EN81-1
- CSA approved limit switch
- Remote set and reset capabilities
- Tested, preset and sealed at factory
- Comes with overspeed switch
- Comes with full rope guard
- Comes with selenoid
- Optional live shaft for encoder available
- Sheave diameter: 305mm/12"
- Rope type: 8 or 9.5mm 8 x S(19) / 3/8"
- Max. pull through: up to 1200lbs
- Min. pull through: 300lbs
- Shipping weight: 35kg/77lbs



Self-Resetting Overspeed Governor Tripping Speed

Speed	100 fpm 0.64 M/S	150 fpm 0.76 M/S	200 fpm 1.02 M/S	250 fpm 1.27 M/S	350 fpm 1.75 M/S	500 fpm 2.54 M/S
Max Overspeed Switch Setting	158 fpm 0.8 M/S	189 fpm 0.96 M/S	252 fpm 1.28 M/S	303 fpm 1.54 M/S	407 fpm 2.07 M/S	563 fpm 2.86 M/S
Max Tripping Speed	175 fpm 0.89 M/S	210 fpm 1.06 M/S	280 fpm 1.42 M/S	337 fpm 1.71 M/S	452 fpm 2.3 M/S	625 fpm 3.18 M/S
Delco SKU	C-12-2100	C-12-2150	C-12-2200	C-12-2250	C-12-2350	C-12-2500

TENSION DEVICE

Swing Arm Type with Cast Iron Weight

Delco's non-proprietary tension device is designed for use with Delco universal elevator governors. This tail sheave / tension device is a swing arm type, the weight is cast iron.

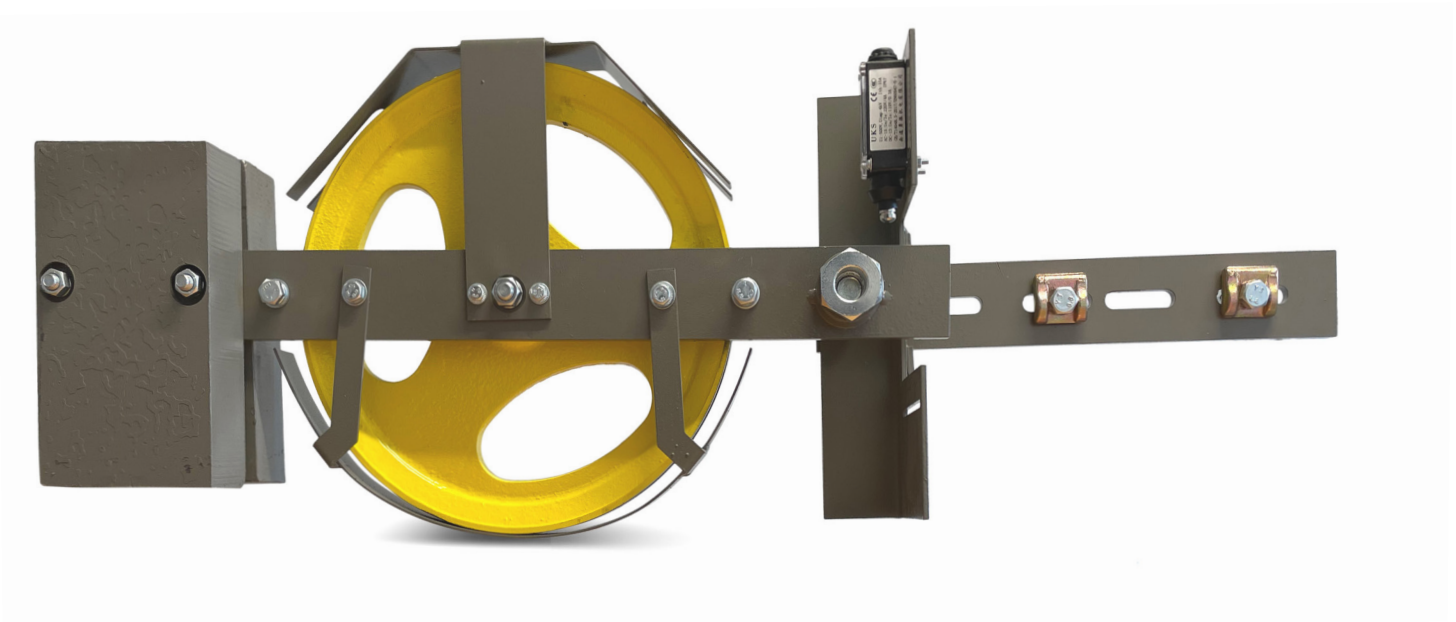

General Specification

Car rated speed range	0.50-2.54 m/s	100-500 FPM
Sheave Pitch Diameter	305 mm	12 inch
Rope Diameter	8.0 or 9.5 mm	5/16 or 3/8 inch
Rope Type	Traction Steel 8 X 19	
Tension force	450 N	101 Lbf
Slack rope Switch	YES	
Installation	Configurable for Left and Right	
Protective cover	YES	
Shipping weight	38.5 kg	85 Lbs
Delco SKU	C-12-4000	

ROLLER GUIDES

8 Models | up to 3000 KG | up to 1200 fpm

With over 12,000 Delco Roller Guide Assemblies installed and running every day, our products are being relied on by hundreds of elevator contractors.

CAPACITY: 0 – 6615 LBS (3000 KG)
SPEED: 0 – 1200 FPM (6.0M/S)

Meeting the requirements for over 90% of elevator installations, Delco offers 8 different RGA models. Low-rise, mid-rise and high-rise buildings throughout North America use Delco Roller Guides.

Easy to install and easy to maintain, Delco Roller Guides are manufactured with high precision, using the best materials, to provide many years of worry-free operation in many different elevator installation situations.

Delco's roller guides are made with the best materials.

Rollers

High quality polyurethane roller tires, with a hardness of 80 ± 5 (Durometer Shore A) provide a comfortable, smooth ride. Polyurethane has a high compression strength and doesn't create flat spots, ensuring reliable operation for many years.

Frame materials

The cast iron frames and heavy duty hardware ensures a long life in all elevator hoistway environments.

Precision Ball Bearings

Delco Roller Guides are made with NSK ball bearings manufactured in Japan, recognized world-wide as the most reliable, high performance bearings.

Product Line

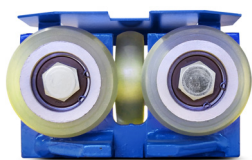

3" SPRING FREE
C-08-0815 (16 mm)
C-08-0817 (10 mm)

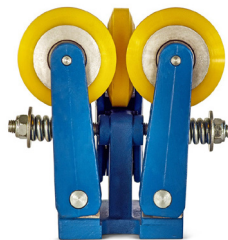

3¼" STANDARD
C-08-0810

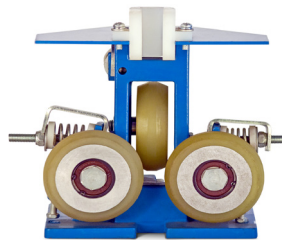

3¼" HIGH SPEED
C-08-0807

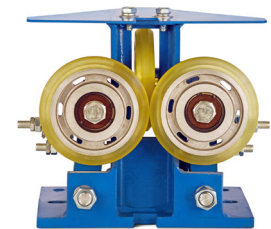

5" STANDARD
C-08-0805

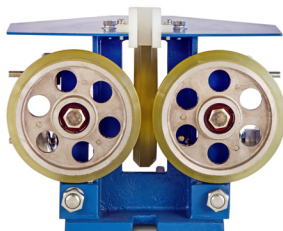

6" STANDARD
C-08-0804



6" SPRING FREE
C-08-0806

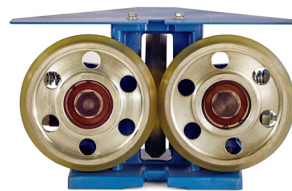

7⅞" STANDARD
C-08-0808

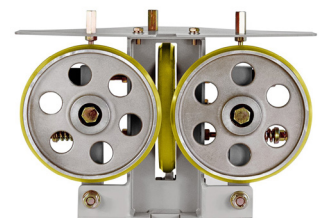

10" HIGH SPEED
C-08-0803

3" SPRING FREE

With Stop Kit and Dust Cover

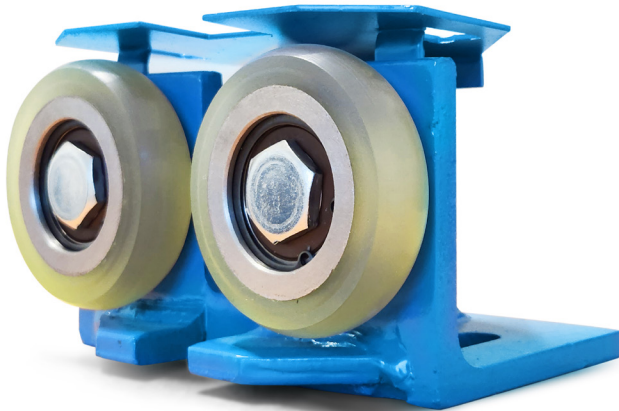

Capacity	up to 6613 Lbs (3000 Kg)
Speed	CWT Side: up to 689 fpm (3.5m/s)
Guide Rail Width	10mm (27/64"), 16mm (5/8")
Roller Diameter	3"(76mm)
Roller Material	Polyurethane
Roller Hardness	80±3 (Durometer Shore A)
Structural Frame	Structural welded profiles
Ball Bearings	NSK 6203DU
Weight	9 Lbs
Delco SKU	C-08-0815 (16 mm); C-08-0815 (10 mm)

3 1/4" STANDARD

Spring Loaded

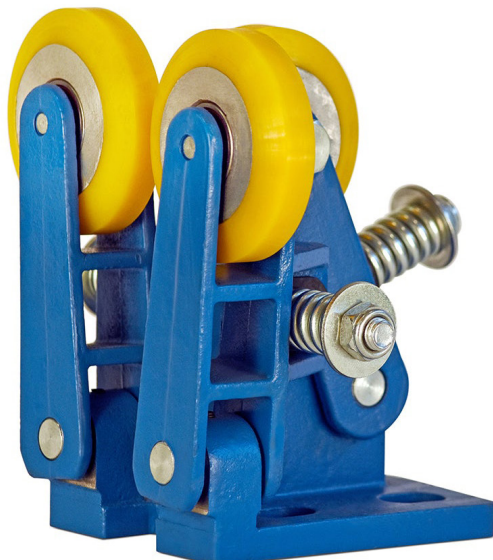

Capacity	Car Side: up to 1388 Lbs (630 Kg) CWT Side: up to 2975 Lbs (1350 Kg)
Speed	Car Side: up to 295fpm (1.5m/s) CWT Side: up to 393fpm (2.0m/s)
Guide Rail Width	10mm (27/64"), 16mm (5/8")
Roller Diameter	3 1/4" (82.55mm)
Roller Material	Polyurethane
Roller Hardness	80±5 (Durometer Shore A)
Structural Frame	Cast Iron
Ball Bearings	NSK 6201DU
Weight	13 Lbs (5.8 Kg)
Delco SKU	C-08-0810

3 1/4" HIGH SPEED

With Stop Kit and Dust Cover

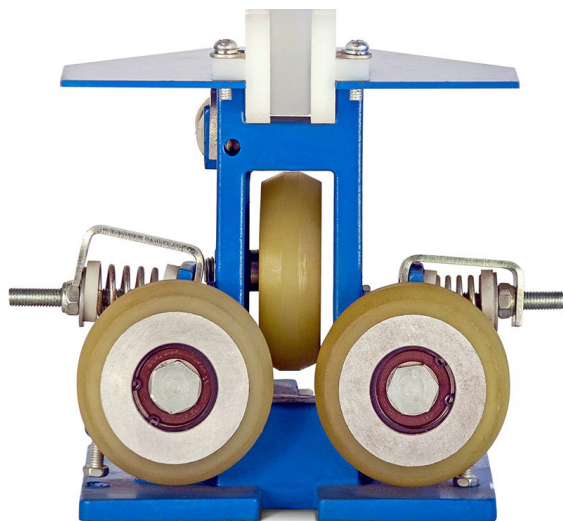

Capacity	up to 3527 Lbs (1600 Kg)
Speed	up to 688 fpm (3.5m/s)
Guide Rail Width	10mm (27/64"), 16mm (5/8")
Roller Diameter	3 1/4" (82.55mm)
Roller Material	Polyurethane
Roller Hardness	80±5 (Durometer Shore A)
Structural Frame	Cast Iron
Ball Bearings	NSK 6003DU
Weight	11 Lbs (5 Kg)
Delco SKU	C-08-0807

5" STANDARD

Spring Loaded with Stop Kit and Dust Cover

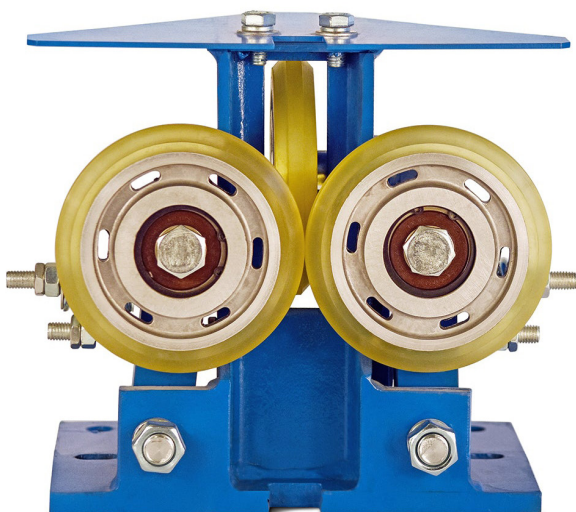

Capacity	up to 3527 Lbs (1600 Kg)
Speed	up to 688fpm (3.5m/s)
Guide Rail Width	10mm (27/64"), 16mm (5/8")
Roller Diameter	5" (125mm)
Roller Material	Polyurethane
Roller Hardness	80±5 (Durometer Shore A)
Structural Frame	Steel
Ball Bearings	NSK 6003DU
Weight	27lbs (12kg)
Delco SKU	C-08-0805

6" STANDARD

Spring Loaded with Stop Kit and Dust Cover

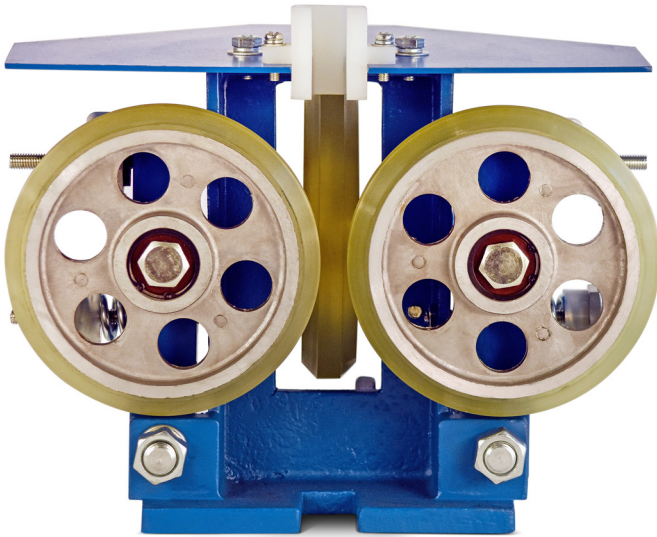

Capacity	up to 3527 Lbs (1600 Kg)
Speed	up to 688 fpm (3.5m/s)
Guide Rail Width	10mm (27/64"), 16mm (5/8")
Roller Diameter	6" (152mm)
Roller Material	Polyurethane
Roller Hardness	80±5 (Durometer Shore A)
Structural Frame	Cast Iron
Ball Bearings	NSK 6006DU
Weight	29 Lbs (13 Kg)
Delco SKU	C-08-0804

6" SPRING FREE

With Dust Cover

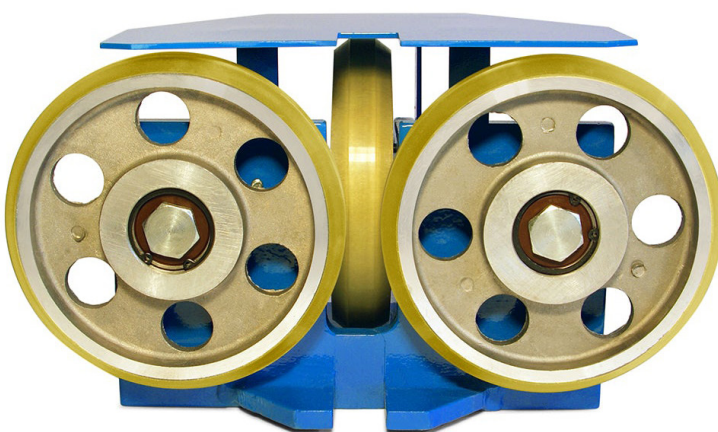

Capacity	up to 6615lbs (3000kg)
Speed	up to 787fpm (4m/s)
Guide Rail Width	10mm (27/64"), 16mm (5/8")
Roller Diameter	6" (152mm)
Roller Material	Polyurethane
Roller Hardness	80±5 (Durometer Shore A)
Structural Frame	Structural Welded Profiles
Ball Bearings	NSK 6203DU
Weight	28 Lbs (13 Kg)
Delco SKU	C-08-0806

7⁷/₈" STANDARD

With Stop Kit and Dust Cover



Capacity	up to 4410 Lbs (2000 Kg)
Speed	up to 787 fpm (4.0m/s)
Guide Rail Width	10mm (27/64"), 16mm (5/8")
Roller Diameter	7-7/8" (200mm)
Roller Material	Polyurethane
Roller Hardness	80±5 (Durometer Shore A)
Structural Frame	Cast Iron
Ball Bearings	NSK 6306DU
Weight	60 Lbs (27 Kg)
Delco SKU	C-08-0808

10" HIGH SPEED

With Stop Kit and Dust Cover

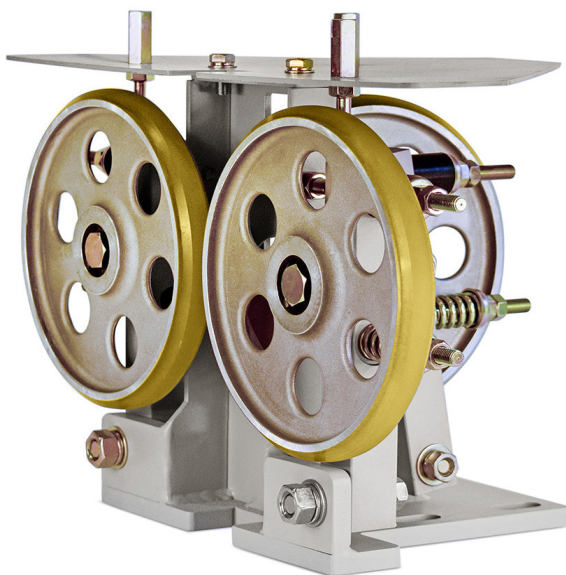

Capacity	up to 6615lbs (3000kg)
Speed	up to 1200 fpm (6.0 m/s)
Guide Rail Width	10mm (27/64"), 16mm (5/8")
Roller Diameter	10" (254mm)
Roller Material	Polyurethane
Roller Hardness	80±5 (Durometer Shore A)
Structural Frame	Aluminum
Ball Bearings	GMB 6004ZZ
Weight	66 Lbs (30 Kg)
Delco SKU	C-08-0803

LSB & MLB SERIES

Low and Medium Speed (200-500 fpm)

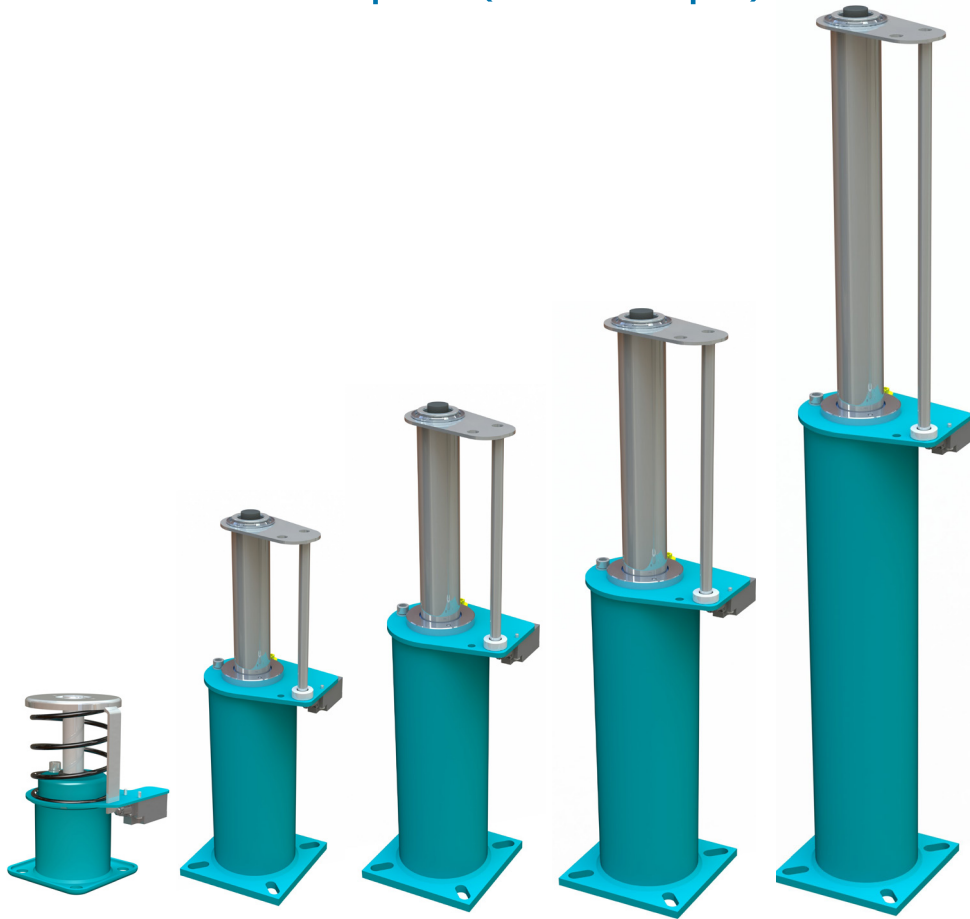

The Oleo Oil Buffer LSB, MLB series are self contained, maintenance free units designed for low and medium speed applications.

This series provides a cost effective solution with excellent performance characteristics across an exceptionally wide mass range.

Oleo buffers are designed and built according to strict engineering standards, universally approved and globally certified.

- LSB 10
- MLB 16
- MLB 18
- MLB 20
- MLB 25
- MLB 35

LSB, MLB Specifications

Product	LSB 10	MLB 16	MLB 18	MLB 20	MLB 25	MLB 35
Rated Speed	200	300	350	400	500	700
Stroke	2.89"	6.81"	8.67"	10.98"	17.13"	34.69"
Overall Height	8.8"	20.9"	24.9"	30.7"	45.8"	83"
Compressed Height	5.7"	13.5"	15.7"	19.2"	28.1"	47.6"
Min Load (lbs)	838	992	992	992	992	1323
Max Load (lbs)	7165	12125	12125	12125	12125	12125
Ship Wt (lbs)	9	28	31	37	54	135
Delco SKU	C-11-2200	C-11-2300	C-11-2350	C-11-2400	C-11-2500	C-11-2700

LB SERIES

Medium and High Speed (315-1200 fpm)

The Oleo Oil Buffer LB series incorporates gas spring technology to provide a premium and robust passenger safety solution for medium to high speed, high mass elevators.

Oleo buffers are designed and built according to strict engineering standards, universally approved and globally certified.

LB buffers have been installed into thousands of landmark buildings since they were introduced more than 30 years ago.

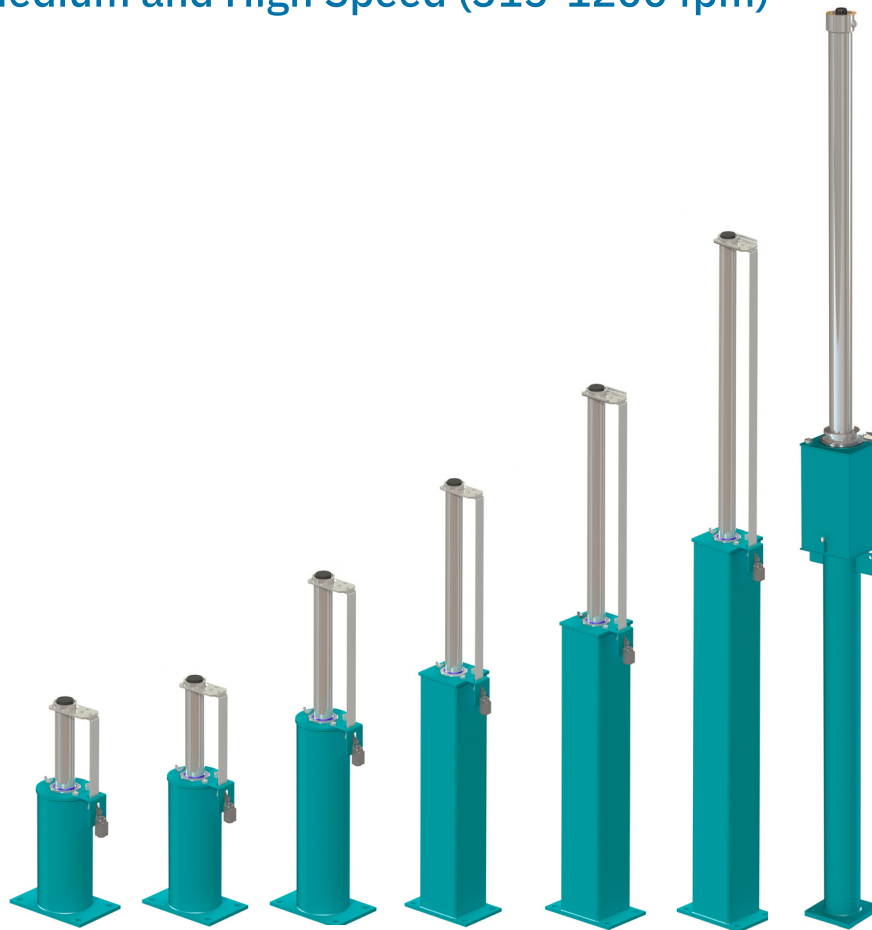

- LB 16
- LB 18
- LB 20
- LB 25
- LB 32
- LB 35
- LB 40
- *LB 50
- *LB 55
- *LB 60
- * Special Order

LB Specifications

Product	LB 16	LB 18	LB 20	LB 25	LB 32	LB 35	LB 40
Rated Speed	300	350	400	500	600	700	800
Stroke	7.99"	9.8"	11.81"	18.19"	27.52"	34.69"	44.92"
Overall Height	24.3"	28.5"	33"	47.7"	67.2"	83"	106"
Compressed Height	15.6"	17.9"	20.5"	28.8"	38.9"	47.6"	60.4"
Min Load (lbs)	1102	1102	1102	1102	1543	2204	2204
Max Load (lbs)	18364	18364	18364	18364	18364	18364	18364
Ship Wt (lbs)	53	59	64	86	122	147	181
Delco SKU	C-11-3300	C-11-3350	C-11-3400	C-11-3500	C-11-3600	C-11-3700	C-11-3800

SHACKLES

Always includes spring, wedge, bushing & clips



Sturdy and tough, Delco offers high quality shackles for an unbeatable price.

Each shackle comes as a complete package including the spring, wedge, bushing & clips at no extra charge.

The full line of shackles has been proven in the field for many, many years and is also CSA approved and TSSA registered.

Ask for a quote today!



Shackles Product Line Specifications

Rope Size	5/16" 8mm	5/16" 8mm	3/8" 9.5mm	3/8" 9.5mm	1/2" 13mm	1/2" 13mm	5/8" 16mm	5/8" 16mm
Overall Length	20" 508mm	24" 610mm	20" 508mm	24" 610mm	24" 610mm	30" 762mm	24" 610mm	30" 762mm
Rod Length	13.7" 348mm	17.7" 450mm	13.98" 355mm	17.93" 455mm	17.01" 432mm	22.91 582mm	18.19" 462mm	23.71" 602mm
Certifications	CSA	CSA	CSA TSSA	CSA TSSA	CSA TSSA	CSA TSSA	CSA TSSA	CSA TSSA
SKU	S-23-19-1011	S-23-19-1012	S-23-19-1003	S-23-19-1004	S-23-19-1102	S-23-19-1101	S-23-19-2102	S-23-19-2101

SAFETY BARRIERS

For elevator and escalator maintenance

Foldable, durable, portable and extremely lightweight, technicians can easily carry Delco Barricades over a shoulder. Available 42" or 84" tall, with your choice of style and configuration.

Customize
With Your
Logo

- Light weight
- Durable
- Folding
- Expandable
- Indoor/Outdoor
- Easy to transport
- Easy to carry
- High visibility
- Code compliant
- Customizable



MODEL 42 SLIM (OPEN)



MODEL 42 BLACK PVC



MODEL 84 TALL



MODEL 42-STAINLESS



MODEL 42 WIDE

MODEL 42 SLIM

Durable, portable and lightweight, the Model 42-Slim is the model of choice for those who are looking for a safety barricade that takes up little space in a van, is easy to carry and is cost effective.

42-Slim Specifications

- Panel size:
42" tall x 18.5" wide (107cm x 47cm wide)
- Frame Material:
1" PVC piping with reinforced corners and t-stops
- Frame Color: Black
- Material: Oxford heavy duty indoor/outdoor canvas
- Standard Symbol: Do Not Enter
- Customization Available: Yes
- Code Compliant: Yes

Delco Part #C-10-0001



42-Slim Configurations

	Standard (4 panels)	Double (8 panels)
Height	42" (107 cm)	42" (107 cm)
Width	74" (188 cm)	148" (376 cm)
Weight	7 lbs (3.15 kg)	14 lbs (6.3 kg)
Part #	C-10-0014	

MODEL 42 BLACK

The Model 42 Black is a highly visible, portable safety barrier constructed with a black, heavy duty PVC frame and high quality canvas. These lightweight and foldable barriers are easy to transport and quick to fold up.

42-Black Specifications

- Panels size: 42" tall x 23" wide (107cm x 58cm wide)
- Frame Material: 1" PVC piping with reinforced corners and t-stops
- Frame Color: Black
- Material: Oxford heavy duty indoor/outdoor canvas
- Standard Symbol: Do Not Enter
- Customization Available: Yes
- Code Compliant: Yes

Delco Part #C-10-0011



42-Black Configurations

	Standard (3 panels)	Double (6 panels)
Height	42" (107 cm)	42" (107 cm)
Width	69" (175 cm)	11'5" or 138" (350 cm)
Weight	6 lbs. (2.65 kg)	12 lbs. (5.3 kg)
Part #	C-10-0011	

MODEL 42 STAINLESS

Our most popular model, this surprisingly lightweight stainless steel barricade provides a sturdy safety barrier with a professional and definitive look. Highly visible, it is constructed with 1" stainless steel pipe frame.



42-Stainless Specifications

- Panel size:
42" tall x 23" wide (107cm x 58cm wide)
- Frame Material:
1" stainless steel piping with reinforced corners and t-stops
- Frame Color: Silver
- Material: Oxford heavy duty indoor/outdoor canvas
- Standard Symbol: Do Not Enter
- Customization Available: Yes
- Code Compliant: yes

Delco Part #C-10-0012



42-Stainless Configurations

	Standard (3 panels)	Double (6 panels)
Height	42" (107 cm)	42" (107 cm)
Width	69" (175 cm)	11'5" or 138" (350 cm)
Weight	7 lbs. (3 kg)	14 lbs. (6 kg)
Part #	C-10-0012	

MODEL 84 TALL



At the full height of 7' these barricades provide complete coverage for an elevator opening.

Quality, stainless steel barricades provide a functional and classy safety barrier for a professional and definitive look.

84 Tall Specifications

- Panels size: 84" tall x 23" wide (107cm x 58cm wide)
- Frame Material: 1" stainless steel piping with reinforced corners and t-stops
- Frame Color: Silver
- Material: Oxford heavy duty indoor/outdoor canvas
- Standard Symbol: CAUTION Maintenance in Progress
- Customization Available: Yes
- Code Compliant: Yes

Delco Part #C-10-0013

84 Tall Configurations

	Standard (3 panels)	Double (6 panels)
Height	84" (214 cm)	84" (214 cm)
Width	69" (175 cm)	11'5" or 138" (350 cm)
Weight	10 lbs. (4.5 kg)	20 lbs. (9 kg)
Part #	C-10-0013	

MODEL 42 WIDE

Extra wide, this model is perfect for escalator applications. A standard 3-panel configuration is 12' wide and can be extended. Sturdy with a professional look, these barricades are constructed with 1" stainless pipe frames. Surprisingly lightweight, at only 11 lbs, they are foldable, easy to transport and quick to fold up. Customize by adding your logo to the center panel.



42-Wide Specifications

- Panel size: 42" tall x 48" wide (107cm x 122cm wide)
- Frame Material: 1" stainless steel piping with reinforced corners and t-stops
- Frame Color: Silver
- Material: Oxford heavy duty indoor/outdoor canvas
- Standard Symbol: Do Not Enter
- Customization Available: Yes
- Code Compliant: yes
- Extendable: yes

Delco Part #C-10-0015



42-Wide Configurations

	Standard (3 panels)
Height	42" (107 cm)
Width	144" (366 cm)
Weight	11 lbs. (5 kg)
Part #	C-10-0015

CARTOP STATION

With LED Flood Light



The Giovenzana Top of Car Inspection Station with adjustable LED Flood Light is designed for safe operation of an elevator car while performing inspections and maintenance.

It features a NO Neutral position Inspection switch, without margin of error in the switch, UP/DOWN car control buttons, ON/OFF light switch, Emergency Stop Button with guards, 2 - 120V GFCI outlets, seismic status with alarm, and fire service button.

The enclosure is made from a high impact thermoplastic material in a highly visible yellow.

Cartop Station Specifications

Color:	Yellow
Connection Type:	Screw Terminals
Contact Rating:	16 A @ 600Vac
Dimensions (L x W x H):	360.08x317.1x118 mm (14.176x12.484x4.646")
Operating Temperature:	-25° - +70°C
Protection Type:	IP65
Wire Connection Type:	Spring Clamp
Delco SKU:	A-GMS355

Features

- Yellow High Visibility Housing
- Knockouts For Easy To Add Wiring ports
- cCSAus certified
- High Impact Poly-carbonate Enclosure
- Failsafe Normal to Inspection cam switch

Options

- LED Flood Light
- Incandescent bulb
- No light

LIMIT SWITCH

With Adjustable Ø50 rubber roller lever



Contact Type:	W02 - 2NC Slow Action Z11- 1NC/1NO Snap Action
Cable Entry:	M20
Max Current (A)	10 Amps
Max Voltage (V):	600 Vac
Protection Type:	IP67
Switch/Button Type:	Limit Switch
Electrical Life:	>150,000 cycles
Mechanical Life:	>10 million cycles
Protection Type:	IP65
Delco SKU:	A-FTNG140-W02 A-FTNG140-Z11

SAFETY SWITCH

Pull Out Safety Limit Switch With Flat Key



Contact Type:	2NC/1NO Slow Action
Cable Entry:	M16
Current Rating (A):	10 A
Key Type:	Flat Key
Max Voltage (V):	600 Vac
Protection Type:	IP67
Switch/Button Type:	Safety Limit Switch
Electrical Life:	>150,000 cycles
Mechanical Life:	>10 million cycles
Protection Type:	IP65
Delco SKU:	A-STNK02-W12

RUN STATION

Temporary Run Station with Tubular key lock



Color:	Yellow
Contact Configuration:	4 NO/1 NC
Contact Rating:	16 A @ 600Vac
Dimensions (L x W x H):	345x81x68 mm
Emergency Stop Button:	Yes
Housing:	Single Row
Motor Control Speed:	Single
Number of Operators:	5
Protection Type:	NEMA 4X and IP65
Delco SKU:	A-PLO5MT-TUBKEY

E-STOP

Emergency Stop Button with Visual Indicator



Color:	Red/Yellow
Contact Configuration:	1NO/1NC
Contact Rating:	16 A @ 600Vac
Dimensions (L x W x H):	75x75x87.1 mm
Emergency Stop Button:	Yes
Housing:	E-Stop Enclosure
Motor Control Speed:	Single
Number of Operators:	1
Operator Type:	Push-Pull
Protection Type:	IP65
Delco SKU:	A-SLA11NPNC001

DOOR DETECTOR

Weco Door Detectors for 24V and 120V



Please, refer to Delco's website for technical details.



24V



120VAC

- Weco Door Detectors are easily installed and competitively priced.
- Ideal for large and heavy doors that have a clutch in the middle of the panel.
- Designed for GAL type doors with heavy duty construction and a full-length box section.
- Every package includes a set of door detectors with travelling cables, power supply, mounting accessories and installation manual.

Specifications

- True Travelling Cables with Plug In Connectors
- Anti Sunlight Function
- Special Model for Both side-opening and Center-Opening doors, with or without Nudging
- 11mm x 27.5mm x 2000mm
- 94 Non-Parallel Infra-Red Beams
- 32 Pairs of Diodes
- 3 Way Scan Mode
- 65ms Response Time
- 59mm Diode Spacing
- 0-3000mm (Max. 4000mm as required) Operating Range
- 20mm-1841mm Detecting Height
- 1:2 Infra-Red Pulses Ratio

- > 100,000LUX Max. Ambient Light (sunlight)
- 15mm Vertical, 4mm Horizontal Linear Tolerance
- 2 x 3,500mm Connection Flexible Cables
- Normal-Interrupted-Faulty System Indicators
- 1 x Yellow LED, 1 x Red LED
- -20°C – 65°C Operating Temperature Range
- -40°C – 85°C Storage Temperature Range
- IP51 (IP54 as required)
- > 1500V Isolation

Model	120VAC	24V	987 - 3D
Delco SKU	B-23-16-0120	B-23-16-0026	B-23-16-0265

We also carry replacement cables and power supplies.

DOOR CLOSER HD

Heavy duty spirator includes bracket and hardware

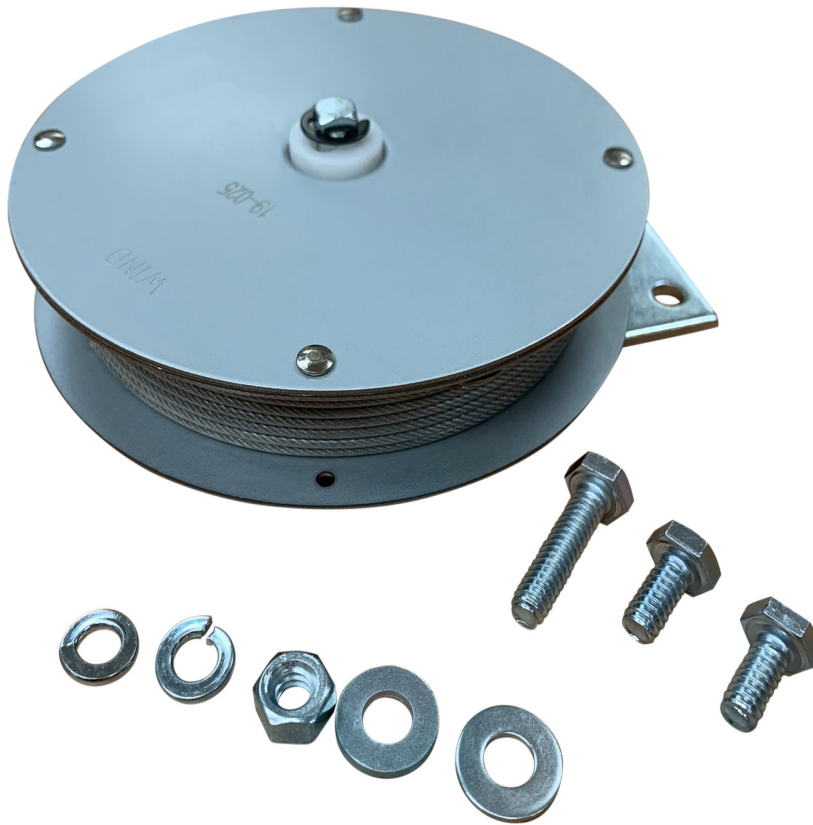

Required by code, hoistway door closers or spirators are an important component that assures passenger safety by automatically shutting elevator doors whenever the car leaves a landing.

The Delco Door Closer HD with bracket CL6-001N has been extensively tested in the field. It is heavy duty, easy to install, dust resistant, vandal resistant and reliable.

Included in each package:

- Door Closer
- Bracket
- Hardware

Door Closer HD Specifications

Diameter	5" (127mm)
Cable	94.5" ±.5" (240cm ±13mm)
Cable retraction force	6.5 lbs (2.95kg) at 4 turns prewind
Overall width including bracket	5.56" (141mm)
Bracket and hardware	included
SKU	B-03-01-0001

BOARDS & PARTS



Delco stocks a wide range of replacement boards and parts including:

- Armor
- Autinor
- Delco
- Dover
- Montgomery
- Otis

Visit our website and search for the item you need.

www.delcoelevators.com

ABOUT DELCO

In Stock, Non-Proprietary, Proven & Competitive

Delco Elevator Products Ltd. has always been a family owned and operated business and is proud to have been helping our customers with elevator components for over 45 years.

With a head office and warehouse in Vancouver, BC, Canada, and a warehouse in Seattle, WA, USA, Delco is strategically located to source, stock and ship elevator products to customers in Canada, the Caribbean and the US.

From MRL packages & machines to popular components, including roller guides, shackles, oil buffers, governors and door edges to a range of elevator parts, the company's comprehensive product selection is one of the reasons that customers have been returning to Delco for decades.

Another reason is that we are very good at ensuring that the right items arrive at the right time to elevator contractors across North America.

Delco's dedicated, experienced and enthusiastic team works diligently to provide exceptional service in the following key areas:

In Stock: We keep our inventory stocked to make sure that customers receive what they need, when they need it.

Non-Proprietary: Delco's products are universal – perfect for modernizations.

Proven Products: Delco manufactures and distributes products that are tried, tested and proven in the field.

Compliant: Delco products and equipment meet all elevator industry compliance and certification standards.

Value for Money: In a highly competitive marketplace, Delco provides the best quality elevator equipment at the lowest possible prices.

Personal, Knowledgeable Staff and Service: Always on hand to assist you with your unique requirements!

HOW TO ORDER

Delco services elevator contractors and OEMs in Canada, the Caribbean and the US, including Puerto Rico and Hawaii.

Phone: 1.604.904.3727 - CAN/USA
Toll Free: 1.866.900.3727
Email: info@delcoelevator.com
www.delcoelevator.com

We'd love to hear from you and give you a quote on your next project. **Call, email or visit us today!**

OFFICE & WAREHOUSE CANADA
#205-3765 1st Avenue
Burnaby, BC V5C 3V8

WAREHOUSE USA
2302 West Valley Highway North, Suite 300, Auburn,
WA 98001

We look forward to welcoming you to our family of customers and friends.



1.866.900.3727

info@delcoelevator.com

www.delcoelevator.com



CANADA

#205-3765 E 1st Avenue

Burnaby, BC V5C 3V8

USA

2302 West Valley Highway North,

Suite 300, Auburn, WA 98001

www.delcoelevator.com
info@delcoelevator.com | 1-866-900-3727

November 2023