

SML-104



OIL COOLING SYSTEMS

**Liquid Cooled Models 2014-2016 • Includes Trikes
Touring models with lower fairings 1994-2016**

**3.0 Dual Fan Assisted
Lower Fairing Mount
For Coolers #SMT-4**

Oil Cooler Installation Guide



Welcome to UltraCool Oil Cooling Systems

Thank you for making UltraCool your oil cooling system of choice. We hope you will find our installation guide helpful in your installation process. If you need more assistance please call our Tech Dept at (951) 698-4962 or email us at info@pcracingusa.com. If you run into a problem with your particular bike or fitting with other accessories etc, please call us before returning as we likely have a solution or part to make it work for you.

Thank you, UltraCool

Tools Required

The tools you will need to complete this installation:

- 2006-2013 Touring models purchase 4 pin electrical connector #RF-170
- New hacksaw blade appropriate for plastic
- Flat head screw driver
- 5/32" Allen wrench
- 2 - 11/16" Open end wrench
- 1/2" and 7/16" Open end wrench
- Ratchet with 3/8" drive
- Extension with 3/8" drive
- 1/2", 7/16", and 1" socket
- Oil Filter wrench
- 17mm socket if installing a FLO Oil Filter
- Torque wrench - check your lbs
- Bike lift - nice to have
- Oil can
- Torx #25, 27, and 40
- Power drill
- 5/16" Drill bit
- Wire Strippers and Crimper
- 7/16" Allen driver (Not a common size.

To remove a stock HD Cooler if necessary. Available from UltraCool #SM-121)



Note: Instructions are illustrated and explained from a rider's point of view

Kit Contents



- A Complete Oil Cooler Assembly
- B Complete Oil Adapter with thermal switch wire
- C LED Indicator Light
- D Wiring Harness
- E Relay
- F Test Jumper
- G Tie Straps
- H Thread Locker
- I Fitting Wrench
- J Hoses
- K Threaded Bushing
- L Blue Wire Connector
- M Frame Clamps & Hardware
- N Double Sided Tape

Step 1 Disassemble Left Lower Fairing



1a. With a flat head screw driver pop off the inside top cover as shown.

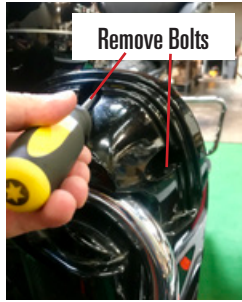

1e. Remove outside bolts to allow removal of inside cover.



1b. Remove inside top nut as shown to allow removal of opposite side cover.



1f. Pinch to disconnect door lever and remove the air door & inside cover.



1c. Remove outer cone cover.



1g. Remove door lever from inside cover.



1d. Remove bottom screws and top nut for removal of inside cover.

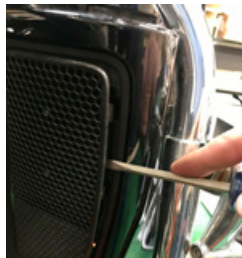

1h. Pop off front grill.



1i. Remove lower fairing while leaving the radiator & water lines in place.

Step 1 Continued

1j.



1k.

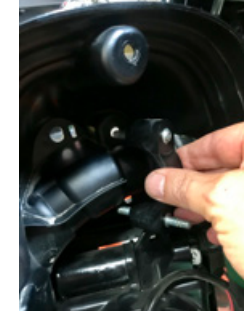

1L. Leave the radiator & water lines in place

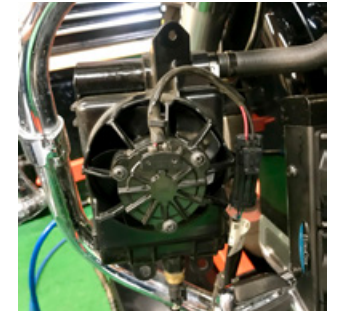

Step 2 Remove the fairing insert

2a. Fairing insert is double side taped into the fairing. Starting at the top corners pry off the tape connection to remove the insert.

2a.

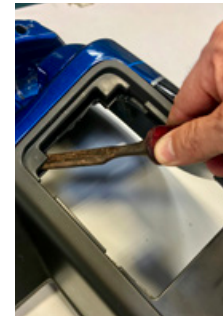

2b.



2c.



2d. Scrape off double sided tape residue



Step 3 Cut Fairing



3a. With new hacksaw blade cut thin edge approx. 3 inches from the top and cut off the top air door pivot arm.



3b. Cut off the bottom air door pivot arm and the thin edge straight across as shown.

Step 4 Cut Fairing Insert



4a. Cut the air door duct off the fairing insert.



4b.

Step 5 Tape the insert back on the fairing

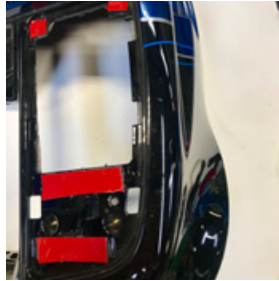

5a. Cut and trim the supplied double side tape to replace the factory tape.



5b. Peel the red layer off the tape and replace the insert back into the fairing. Press hard on the taped areas.

Completed Fairing



2013 and older fairings cut where indicated.

Step 6

Remove Oil Filter

Remove oil filter and clean up any oil and dirt. All surfaces must be oil and dirt free.



Step 7

Remove Old Cooler

If you have a cooler on your non-liquid cooled bike you will need to remove it and all parts associated with it. Use 7/16" allen driver (UltraCool part # SM-121) in the center of adapter and it will come off. You will need to install our threaded bushing provided in your parts bag.



If you don't have a cooler go to step 8.



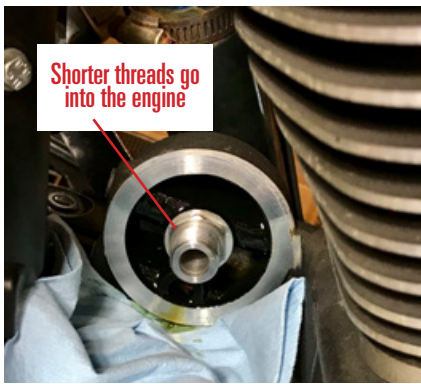

Step 8 Threaded Bushing Installation

Remove the threaded bushing from your engine with 7/8" socket. Install the new threaded bushing provided in your parts bag. Use red or blue thread locker on short end and torque to 18-22 FT.-Lbs.

Step 9 Oil Adapter Installation

Locate the oil adapter and take it to a clean surface. Using a 5/32" Allen driver remove the 6 bolts from the front as shown. Watch out for small washers! Note: there are (4) 1 - 1/8" and (2) 3/4" bolts and (6) washers.

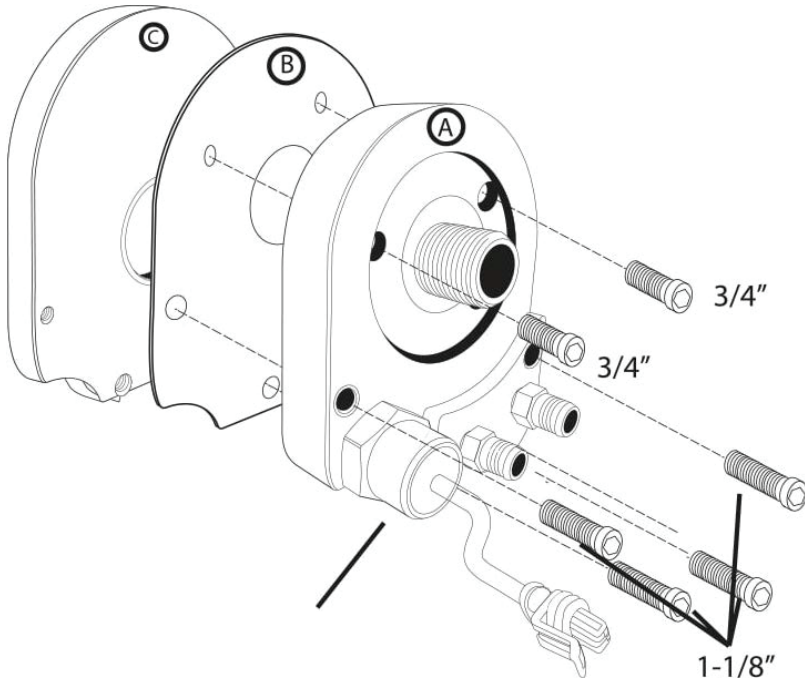

Step 10 Install Plate "C"

Notice that parts of the adapter are marked A-B-C in drawing on previous page. Take part C and look on the back, there are two alignment cams. Place part C over the oil filter mount in the 11:00 position. Now take the 1" nut and add a few drops of blue thread locker to it, and tighten to threaded adapter on oil filter mount. Torque to 18-22 Ft Lbs, or 216-264 Inch Lbs.



Step 11 Plate (A) and Gasket Install

Locate parts A and B of the oil adapter, (2) 3/4" bolts and the washers. Screw the bolts in as shown. This will hold the gasket in place. Now hand start top bolts. Use a 5/32" Allen Wrench for the bottom and hand tighten. Get the (4) 1 - 1/8" along the bottom and hand tight. **Use Blue Thread Locker on Bolts.**





Step 12

Torque Oil Adapter

Now all of the bolts and washers are installed and hand tight. Use a torque wrench and set it to 5 Ft Lbs or 60 Inch Lbs and tighten in a star pattern as shown.

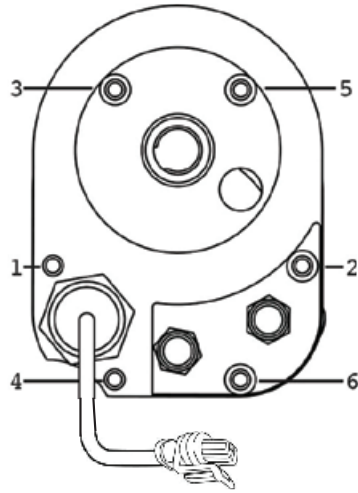

Step 13

Frame Clamps

Put the frame clamps into position. You may need to loosen the bracket holding the lines near the frame. Use thread locker on all bolts especially the clamp bolts.

Step 14

Mount Heat Exchanger

Mount the heat exchanger with the clamps, bolts, and lock washers. Don't tighten the bolts on the clamps completely so you can slide the clamps as low as possible until the top clamp hits the frame cross member. Connect the hoses before completely tightening the clamp bolts.



Step 15

Oil Fittings & Tighten Hoses

Very important to oil the oil line fittings then install the hoses as shown.

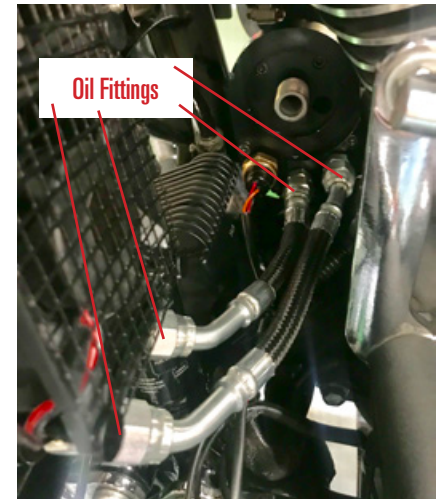

Use provided tool to tighten.



Step 16 Installing Relay Harness

Remove left saddle bag, left side cover and seat. Remove main power fuse. Connect black ring connector to battery negative side. Connect red ring connector to battery positive side.

2014-2016 models

Connecting the Blue Trigger Wire (2 options)

1) Recommended connection: Purchase a Harley Davidson Electrical Connection Kit #69200723 or #69200722 (most HD dealer stock this). Follow HD Harness instructions, connect blue wire to violet/blue wire.

2) Use our tap provided. Connect blue wire to violet/blue wire of gray connector at the bottom of the fuse box.

1994-2013 models

Installing Relay Harness with Gray

4 Pin Connector #RF-170 (sold separately)

Connect blue wire to blue wire on gray connector and do nothing with orange wire (recommended). Plug gray connector into black P-A connector. (This is under the seat). The 2-prong white connector will go to the wiring harness in step 12. Secure harness with zip ties provided.

Orange Wire Option:

Manual operation not recommended. This option will turn the fans on and off with the accessory switch located on the fairing. Connect test jumper to the thermal switch connector. Now the switch will control the fans.



Relay Harness

- 1) Black Ring Connector-Battery Negative.
- 2) Red Ring Connector-Battery Positive.
- 3) White Power Connector to Harness.
- 4) Blue Trigger Wire
- 5) Black with Logo is Relay

Step 17

Install Wiring Harness

The black connector is for the thermal switch. The gray connectors are for the fans and LED. (Does not matter which one).

The LED is optional. From the adapter run and attach harness down left frame rail, up along side of electrical fuse box and connect white connectors. Secure harness with zip ties provided.

Wiring Harness

- 1) White Power Connector
- 2) Grey Connectors to Fan and LED Light (Interchangeable)
- 3) Black Connector to Thermal Switch

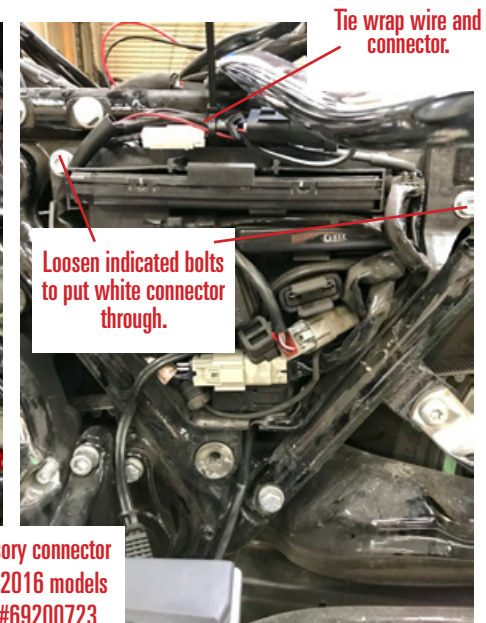

HD accessory connector for 2014-2016 models HD Part #69200723

Loosen indicated bolts to put white connector through.

Tie wrap wire and connector.

Step 18

Installing LED

3 Options:

1) We have a small toggle mount that fits under a screw on your handlebar controls Part #AC-21B (included in your kit).

2) You can mount the LED light in a fairing by drilling a 5/16" hole.

3) We have a handlebar LED light clamp for 1" handlebars only. Available in Chrome part #AC-20C, Black part #AC-20B, and Black Chrome part #AC-20BC. These are available at UltraCoolfl.com or any UltraCool Dealer.

Install LED light connector last so you can feed the LED wire through tight areas on the handle bars, frame, etc. To install the LED connector, push the 2 wires through the back of the connector — either way is fine. Be careful not to break wire connectors when pushing through. Use the orange clip as shown to snap/lock the wires in place.

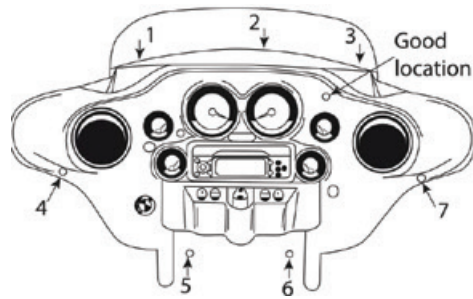

Step 19

Reassemble Fairing

Reassemble the modified fairing on the bike by reversing the disassembly instructions.



Step 20

Test Electrical Connections

Locate the test jumper in your parts bag. Unplug harness from the thermal switch and plug jumper into the harness instead. Turn on bike ignition. Fans and LED light should run.



If the fans and LED work with the test jumper, remove the jumper and plug in the thermal switch. Save the test jumper to trouble shoot in the future.

Step 21

Check List

- Check Hoses are tight
- Install Oil Filter and Clean up any oil
- Start Engine and Check oil

Trouble Shooting:

If the oil line fittings leak at all, simply loosen and retighten the fitting with the provided tool.

Congratulations! You are good to go!

Note: On your next warm day ride (after a minimum of 10 miles) the fans will turn on when the oil reaches 210 degrees. Do not test by letting your engine idle in your driveway as this will not get your oil hot.



Accessories

Notes

FLO Oil Filter

Provides additional 10 degrees of cooling power and consistent filtering across the entire surface. Flows 7 times more than paper or synthetic filters while filtering to 35 microns (absolute, 1 pass test). Unaffected by water, heat or pressure and the bypass valve will not open on cold startups and

high RPM. Built in 17mm hex nut for easy removal. It is easily cleaned and reused,

paying for itself. Available in Polished Aluminum with clear anodize part #PCS4C or Black anodize part #PCS4B. (We do not chrome or paint our filters as that holds in heat)



LED Light Handlebar Clamp

A very stylish way to mount your LED light to 1" handlebars.



Chrome #AC-20C



Black #AC-20B



Black Chrome #AC-20BC

LED Toggle Mount

Mounts LED to handlebar controls. Part #AC-21B
(included in kit)





OIL COOLING SYSTEMS

(951)698-4962 • info@pcracingusa.com
UltraCoolfl.com

WARRANTY

One year parts only from date of purchase.

Warranty registration must be completed in full and received
within 45 days of purchase to validate warranty.

Warranties are non-transferrable

Register for warranty at www.UltraCoolfl.com/warranty-registration/

Disclaimer: PC Racing UltraCool is not liable or responsible whatsoever
for any claims for damages or injury subsequent to improper
installation or modification of our products. Intended for stock motorcycles.

Patent #6955150

Please follow us on:

Instagram @UltraCoolfl

Facebook @UltraCoolOilCoolingSystems

