



FERTILIZER COULTER

MODEL 2995/2996

SET-UP & PARTS MANUAL

2565-369_REV_F - 02/2019

YETTER MANUFACTURING CO.
FOUNDED 1930

Colchester, IL 62326-0358
Toll free: 800/447-5777
309/776-3222 (Fax)
Website: www.yetterco.com
E-mail: info@yetterco.com

YETTER

FOREWORD

You've just joined an exclusive but rapidly growing club.

For our part, we want to welcome you to the group and thank you for buying a Yetter product.

We hope your new Yetter products will help you achieve both goals-increase your productivity and increase your efficiency so that you may generate more profit.

This operator's manual has been designed into four major sections: Foreword, Safety Precautions, Installation Instructions and Parts Breakdown.



This **SAFETY ALERT SYMBOL** indicates important safety messages in the manual. When you see this symbol, be alert to the possibility of **PERSONAL INJURY** and carefully read the message that follows.

The word **NOTE** is used to convey information that is out of context with the manual text. It contains special information such as specifications, techniques and reference information of a supplementary nature.

The word **IMPORTANT** is used in the text when immediate damage will occur to the machine due

to improper technique or operation. Important will apply to the same information as specified by note only of an immediate and urgent nature.

It is the responsibility of the user to read the operator's manual and comply with the safe and correct operating procedure and to lubricate and maintain the product according to the maintenance schedule in the operator's manual.

The user is responsible for inspecting his machine and for having parts repaired or replaced when continued use of the product would cause damage or excessive wear to the other parts.

It is the user's responsibility to deliver his machine to the Yetter dealer who sold him the product for service or replacement of defective parts, which are covered by the warranty policy.

If you are unable to understand or follow the instructions provided in this publication, consult your local Yetter dealer or contact:

YETTER MANUFACTURING CO.

309/776-4111

800/447-5777

309/776-3222 (FAX)

WARRANTY

Yetter Manufacturing warrants all products manufactured and sold by it against defects in material. This warranty being expressly limited to replacement at the factory of such parts or products as shall appear to be defective after inspection. This warranty does not obligate the Company to bear cost of labor in replacement of parts. It is the policy of the Company to make improvements without incurring obligations to add them to any unit already sold. No warranty is made or authorized to be made, other than herein set forth. This warranty is in effect for one year after purchase.

Dealer _____

Yetter Manufacturing warrants its own products only and cannot be responsible for damages to equipment on which mounted.

SAFETY

A brief description of signal words that may be used in this manual:

CAUTION: Used as a general reminder of good safety practices or to direct attention to unsafe practices.

WARNING: Denotes a specific potential hazard.

DANGER: Denotes the most serious specific potential hazard.

SAFETY PRECAUTIONS

You can make your farm a safer place to live and work if you observe the safety precautions given. Study these precautions carefully and insist that they be followed by those working with you and for you.

Finally, remember this: an accident is usually caused by someone's carelessness, neglect or oversight.

WARNING

Never clean, lubricate or adjust a machine that is in motion. Always lower or block the implement before performing service.

If machine must be serviced in the raised position, jack or block it up to prevent it from accidentally falling and injuring someone.

Do not allow riders on the tractor or implement.

Use speeds and caution dictated by the terrain being traversed. Do not operate on any slope steep enough to cause tipping or loss of control.

Be sure all personnel are clear of the immediate area before operating.

Read and understand the operator's manual and require all other persons who will operate the equipment to do the same.

Be familiar with all tractor and implement controls and be prepared to stop engine and implements quickly in an emergency.

CAUTION

Consult your implement and tractor operator's manual for correct and safe operating practices.

Beware of towed implement width and allow safe clearance.

FAILURE TO HEED MAY RESULT IN PERSONAL INJURY OR DEATH.

YETTER MODEL 2995/2996 FERTILIZER COULTER

CLAMPS

<i>Part No.</i>	<i>Description</i>
2990-153	Clamp Kit, 2" Sq. Bar
2990-154	Clamp Kit, 2 1/2" Sq. Bar
2990-155	Clamp Kit, 2 x 6 Bar
2990-156	Clamp Kit, 4 x 4 Bar
2990-157	Clamp Kit, 5 x 7 Bar
2990-158	Clamp Kit, 7 x 7 Bar
2990-159	Clamp Kit, 3" Dmd Bar
2990-160	Clamp Kit, 3 1/2" Dmd Bar
2990-161	Clamp Kit, 3 x 7 Bar
2990-162	Clamp Kit, 2 1/2" Sq., 1/2" Spacer
2990-163	Clamp Kit, 3" Sq. Bar
2990-166	Clamp Kit, 2 1/4", 2 1/2" Dmd Bar
2990-171	Clamp Kit, 3 x 4 Bar
2990-172	Clamp Kit, 4 x 6 Bar
2990-173	Clamp Kit, 6 x 4 Bar
2990-174	Clamp Kit, 7 x 5 Bar
2990-175	Clamp Kit, 7 x 4 Bar
2990-181	Clamp Kit, 4 x 10 Special
2990-182	Clamp Kit, 4 x 7 Bar
6300-105	Clamp Kit, 5 x 5 Bar

SHANKS

<i>Part No.</i>	<i>Description</i>
2990-208	Shank, 12 5/8" Long, 3" Offset
2990-221	Shank, 27" Long, 3" Offset
2990-310	Shank, 12 5/8"
2990-318	Shank, 16"
2990-328	Shank, 26"
2990-342	Shank, 18" Long, 3/4" Offset
2990-350	Shank, 27 1/8"
2990-353	Shank, 22" Long, 3/4" Offset
2990-354	Shank, 18" Long, 5 1/2" Offset
2990-370	Shank, 30" Long
2990-377	Shank, 15" Long, 5 1/2" Offset
3010-303	Shank, 22"
3011-302	Shank, 22" Long, 5 1/2" Offset
6300-331	Shank, 19" Long, 3/4" Offset

FERTILIZER KNIVES

2975-232	Dry Fertilizer Knife
2975-220	Liquid Fertilizer Knife

OPTIONAL EQUIPMENT

2975-120	Gauge Wheel Kit
2970-133	Knife Scraper 17"
2976-133	Knife Scraper 20"

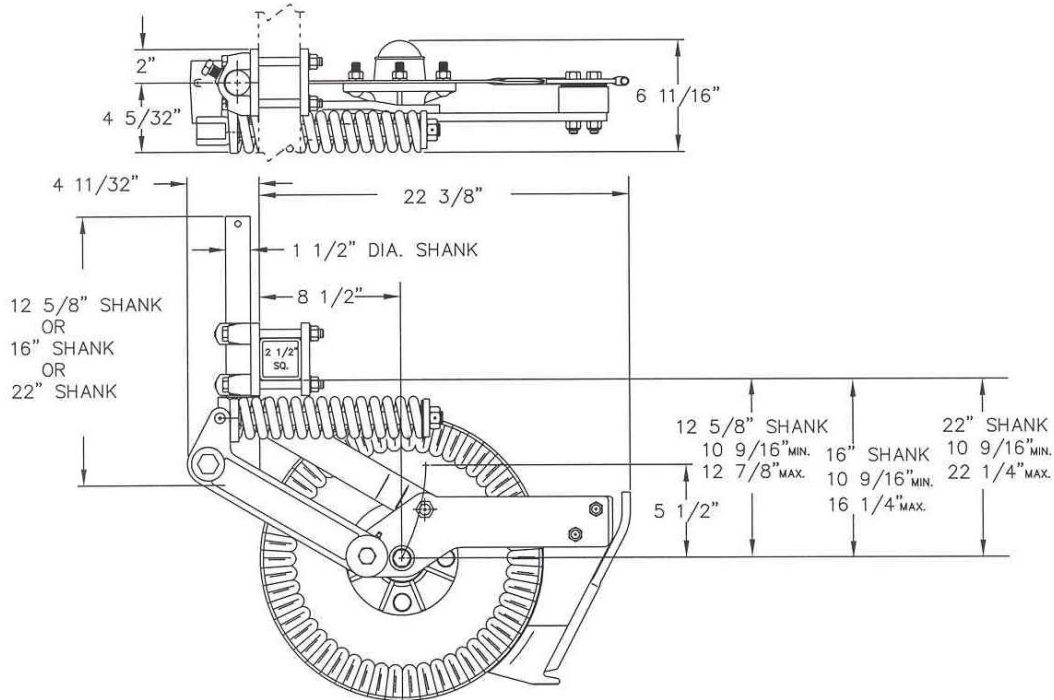

S324

INSTALLATION

1. Assembly 3/8 x 2-1/2" roll pin into hole closest to end of 1-1/2" diameter shank, leaving approximately equal amount protruding out each side. For 12-5/8" shank, end without hole is upper end.
2. Insert lock collar into pivot casting and slide shank up through casting and lock collar. If you wish to lock coulters from pivoting, slide roll pin into slots in casting. If you wish to let coulters pivot, do not align roll pin with casting slots, but slide shank up till roll pin contacts casting surface. Install and tighten 5/8 x 1" setscrew in lock collar to 110 ft. lb. torque maximum.
3. Mount 17" coulters blade loosely to hub using four 1/2" carriage bolts, lockwashers and nuts.
4. Mount fertilizer knife and spacer block to rear support arm using two 1/2 x 3-1/2" Gr. 8 bolts, hardened flatwashers and lock nuts. Place shims between knife and support arm as required to align knife point with blade.
5. **Center blade on hub** by rotating blade and watching clearance between knife and blade. Slide blade on hub as required until the blade runs concentric, no run out on diameter. Tighten four 1/2" nuts. **The disc blade must run concentric.**
6. Adjust knife clearance to blade **as close as possible**. The high point of the blade should **just** clear the knife as blade is rotated. Be sure blade rotates freely then tighten two 1/2" locknuts to 120 ft. lb. Re-check clearance, by rotating blade one full revolution, after all bolts are tightened.
7. Assemble clamp components loosely to planter front bar as shown in parts view of appropriate clamp.
8. Position coulters clamps either toward the inside or outside of the planter openers on each side of the planter to equalize draft. Tighten four 1/2" nuts to secure the clamps.
9. Install coulters on planter by inserting shank up through clamps and tightening 5/8 x 1" setscrews.
10. Install 5/16 x 2-1/2" cotter pins in all vertical 1-1/2" diameter shanks. This cotter pin prevents loss of coulters should the clamp setscrews work loose. Cotter pin can be installed between clamp castings or on top, above top casting depending on shank.
11. Set coulters depth by loosening setscrews in clamp castings. For John Deere 7000 front fold planters there may not be enough up adjustment to operate coulters at proper depth, not more than hub deep. Not all toolbars on John Deere planters operate at the same height. If necessary, cut off top of 1/12" diameter shank to allow proper adjustment.
12. On John Deere 7000 front fold planters there are two hoses that may interfere with coulters operation. Loosen hydraulic fittings and swivel hoses up out of the way to provide clearance when coulters flex up.
13. Let coulters swivel, set lock collar to allow swivel in one or both directions as required. Tighten set screw to 110 ft. lb. torque maximum.
14. Tighten 3/4" locknut if greater spring pre-load is required.
15. Grease three fittings on each coulters before operation. The hub bearings should be greased only a few times each season. **Do not forget the lower parallel arm grease zerk.**
16. NEVER mount coulters under planter drive shaft to allow coulters blades to contact shaft when an obstacle is struck. Coulters must be mounted so blade can always flex up and clear drive shaft.

NOTE: Dry fertilizer must be free of chunks greater than 1/4" in size to prevent plugging. Yetter recommends using screened fertilizer or running fertilizer through screen when hoppers are filled. Clean hoppers thoroughly at the beginning of season to prevent plugging problems.

The rubber dry fertilizer tube may appear to be 'stretched' when the planter is in the transport position. This does not affect operation of the planter and should not be detrimental to the fertilizer tube.

OPERATION PRECAUTIONS

STOP

Read this before using the Yetter product.

- MACHINE OPERATION

IMPORTANT: failure to properly set the planter frame height and levelness can result in less than successful operation of the planter and the Yetter product and may result in damaged equipment. All operators should read and thoroughly understand the instructions given prior to using the Yetter product.

NOTE: **DO NOT** use this product if the planter is not adjusted properly!

Leveling the planter:

With the planter lowered to proper operating height (**Usually 20"-22"**). **Read the planter operator's manual for recommended setting**. Check to be sure the toolbar and row unit parallel arms are level fore and aft. **Re-check** when the planter is in the **field** and has been **fully loaded** with seed, fertilizer, granular chemicals, etc. Also, a field check with a bubble level on the frame should be made of the hitch height to ensure level operation front to back.

It is important for the planter to operate level laterally. Tire pressure must be maintained at pressures specified by the manufacturer.

Field and actual planting conditions change and will dictate planter frame heights. You must ensure that the row unit parallel arms are approximately parallel with the ground.

IMPORTANT: For proper operation of the planter attachments and row units, it is imperative that the planter toolbars and row unit parallel arms be level side-to-side and front-to-rear. The toolbar frame should operate at a 20"-22" height from the **planting surface**. Check the manufacturer's operator's manual for instructions on how to adjust the frame height and levelness.

PLANTER ADJUSTMENT

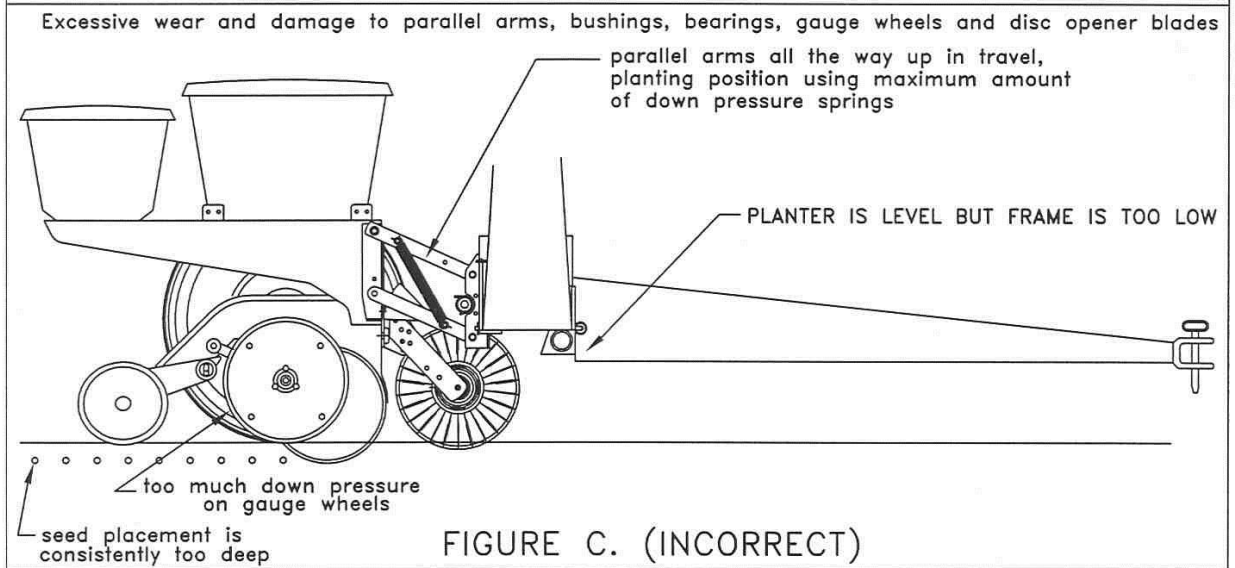
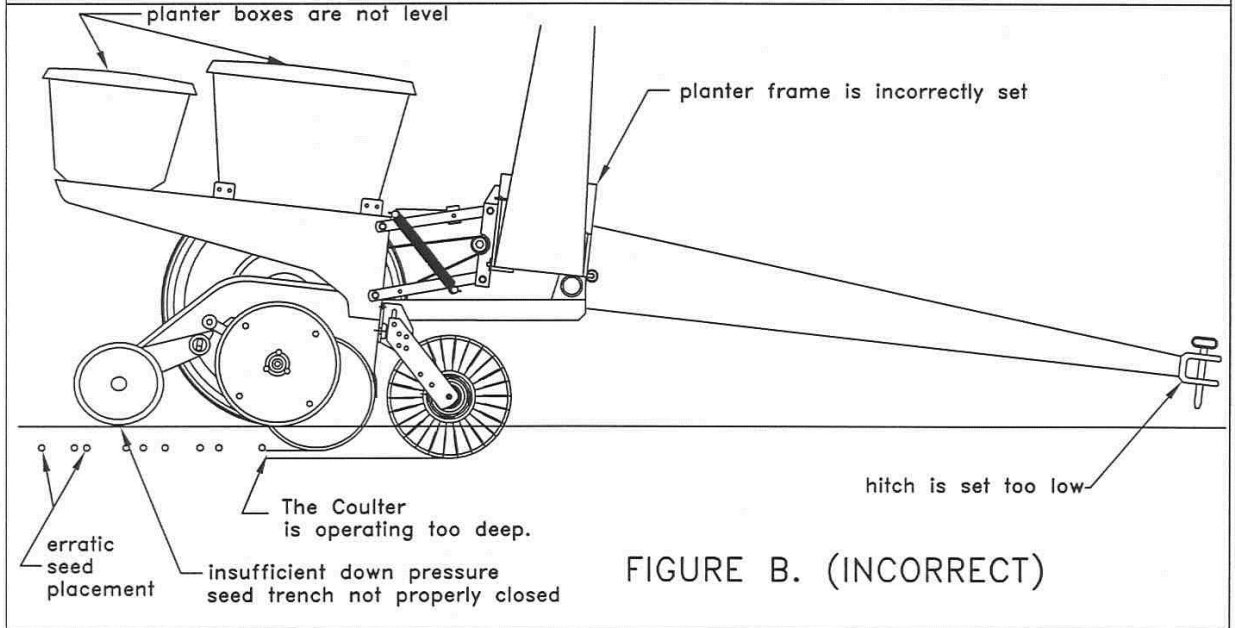
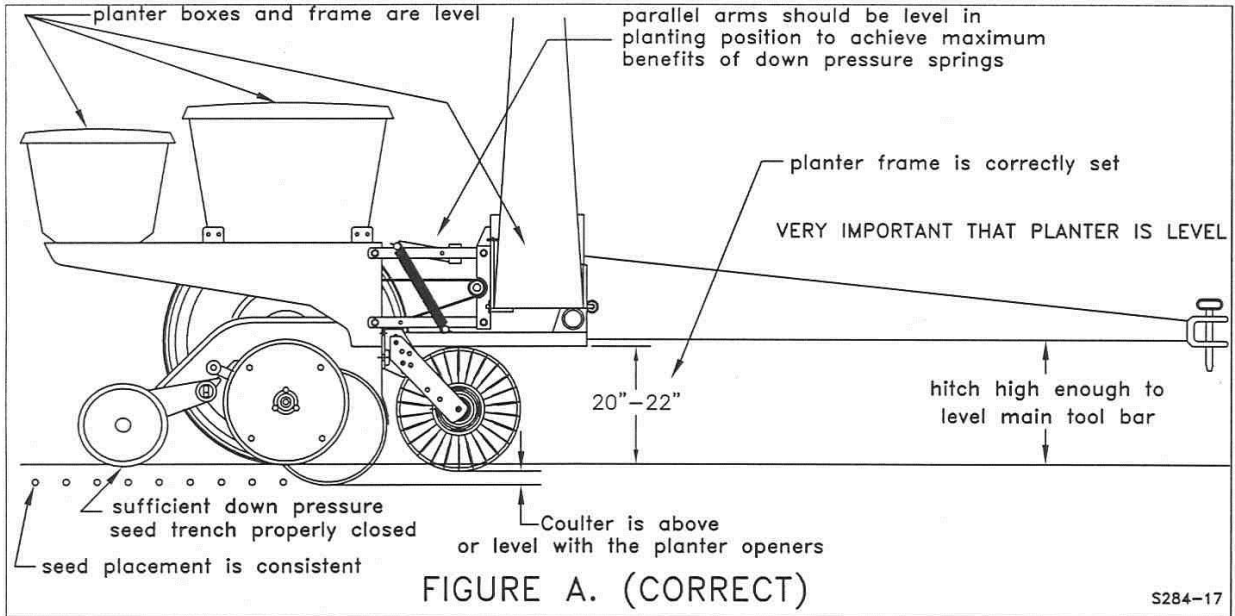

OPERATION

Yetter Model 2995 fertilizer coulters are designed to apply fertilizer 3" to 5" deep. See your fertilizer dealer for recommended depth and distance away from row for your particular fertilizer. A popular placement setting is 2" below and 2" away from the seed. High deposit rates require the fertilizer to be placed farther away from the row to avoid crop "burn".

Yetter Model 2995 fertilizer coulters can be set up to swivel or not swivel as required. By not allowing the coulters to swivel, the distance between seed and fertilizer varies less when planting on contour.

When mounting Model 2995 coulters on 3-point or 2-point hitch planters, the coulters should be set up to swivel, particularly if a 4-wheel drive tractor is used. This reduces the side load on the coulters during operation. It is preferable to allow the coulters to swivel.

IMPORTANT: For proper operation, the planter frame must operate level and at the correct height, usually 20" – 22" while in operation.

In hard no-till conditions the desired operating depth may not be possible. Tighten spring nut to maintain depth if spring is flexing rather than lower coulters to obtain maximum depth.

Planter weight may limit operating depth in hard conditions, particularly with mounted or semi-mounted planters. Be sure planter has enough weight to keep drive wheels on the ground during operation or plant populations can be drastically affected.

1. Set coulters blades to run vertical to ground. Operation depth and blade wear can be affected if coulters are mounted crooked. If coulters are set-up to not swivel be sure they run straight with the direction of travel.
2. After a few hours use, check all bolts and setscrews for tightness.
3. After a few days use, check coulters hubs for loose bearings. There should be no end play in the hub bearings to allow it to wobble. If necessary, remove hub cap and cotter pin, adjust slotted nut to remove wobble, re-insert cotter pin and replace hub cap.
4. **KNIFE ADJUSTMENT IS CRITICAL.** Adjust knife-blade clearance regularly, see page 7. An optional knife scraper, Part #2970-133, is available to reduce the frequency of adjustment on the fertilizer coulters knife. In addition this allows better operation in tough conditions such as freshly disked soils with abundant trash in the top four inches of loose soil. NOTE: A 'bump' will appear behind knife scraper, on blade where protected, this must be ground off periodically to maintain correct knife-blade clearance.
5. **BLADE WEAR** can affect operation in loose trash conditions. If knife adjustment does not stop plugging problems, it may be necessary to replace blade.

MAINTENANCE

LUBRICATION

Each coulters is equipped with three grease zerks. To ensure longevity and reliability of the coulters, the following lubrication schedule should be followed:

1	Lower parallel arm zerk	daily
1	Pivot casting zerk	daily
1	Hub bearings zerk	each season

KNIFE WEAR

The lower portion of the knife and tube are subject to wear during operation. The rate of wear will depend on a variety of factors and in abrasive soil conditions the wear will be more rapid.

On the dry fertilizer knives with cast tip, if the tube is worn, it is possible to weld on a new tube (2975-360) to further extend the life of the dry fertilizer knife or weld on new wear plates (2975-387) on each side.

KNIFE ADJUSTMENT

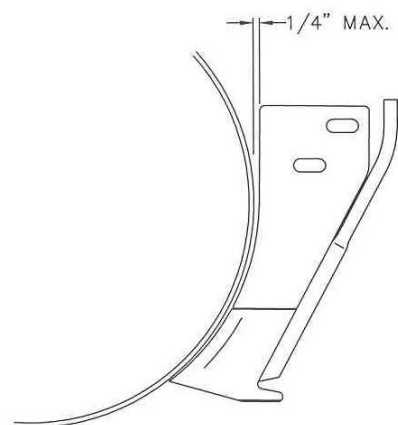

CORRECT

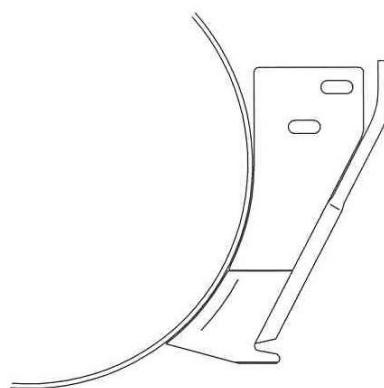

CORRECT

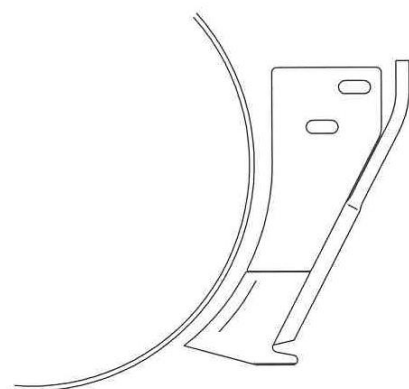

INCORRECT

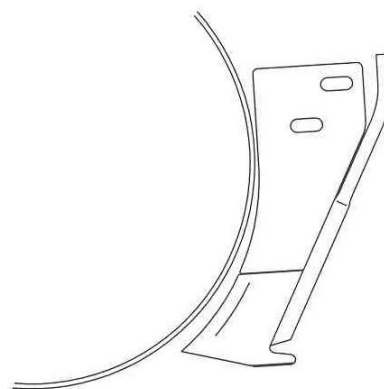

INCORRECT

S 286

The adjustment of knife clearance to the blade is critical to trouble free operation of the fertilizer coupler, in certain conditions the coupler can “plug” in just a few feet if not correctly adjusted.

1. The disc blade **must** run concentric. Adjust by loosening four hub nuts and centering the blade.
2. **Set knife to rub slightly on blade, especially at bottom of knife. See illustrations above. 2975-125 does work with 2995 coupler.**

PARTS IDENTIFICATION

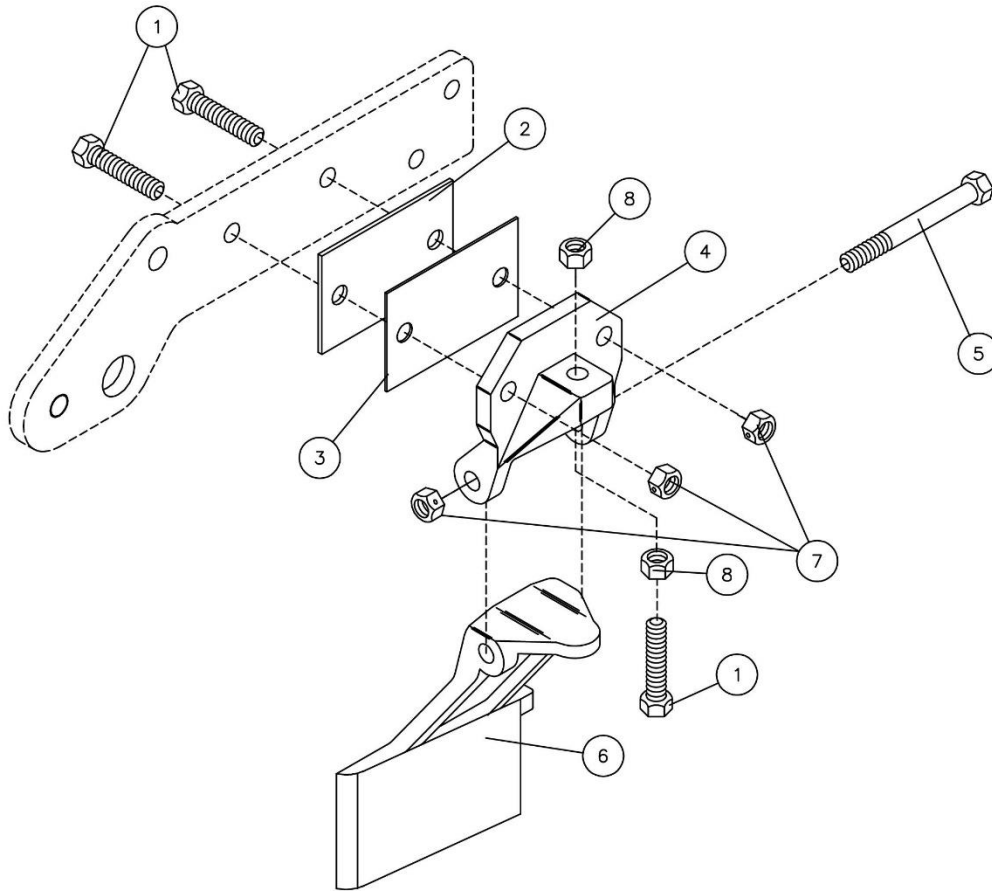

1308

SIDE KNIFE KITS

2995-122 Liquid Side Knife Assy., L.H. 2995-124 Dry Side Knife Assy., L.H.
 2995-123 Liquid Side Knife Assy., R.H. 2995-125 Dry Side Knife Assy., R.H.
 To be used with 2571-165 or 2571-169 blades only.

2996-114 LH 5-1/2" Liq Side Knife Assy. 2996-116 LH 5-1/2" Dry Side Knife Assy.
 2996-115 RH 5-1/2" Liq Side Knife Assy. 2996-117 RH 5-1/2" Dry Side Knife Assy.
 To be used with 2571-178 blade only.

Key	Qty.	Part No.	Description
1	3	2502-346	1/2-13 x 2 HHCS Gr. 5 ZP
2	2	2995-316	Side Knife Shim, 1/8", ZP
3	1	2995-315	Side Knife Shim, 16 Ga., ZP
4	1	2995-314	Side Knife Brkt., 2995
5	1	2502-362	1/2-13 x 5 HHCS Gr. 5 ZP
6	1	2995-121	Liquid Side Knife Assy., R.H. (Shown)
	1	2995-120	Liquid Side Knife Assy., L.H.
	1	2995-200	Dry Side Knife W.A., L.H.
	1	2995-201	Dry Side Knife W.A., R.H.
	1	3000-123	LH 5-1/2" Liq Side Knife S.A.
	1	3000-124	RH 5-1/2" Liq Side Knife S.A.
	1	3000-234	LH 5-1/2" Dry Side Knife W.A.
	1	3000-235	RH 5-1/2" Dry Side Knife W.A.
7	3	2520-357	1/2-13 Lock Hex Nut ZP
8	2	2520-352	1/2-13 Hex Nut ZP

PARTS IDENTIFICATION

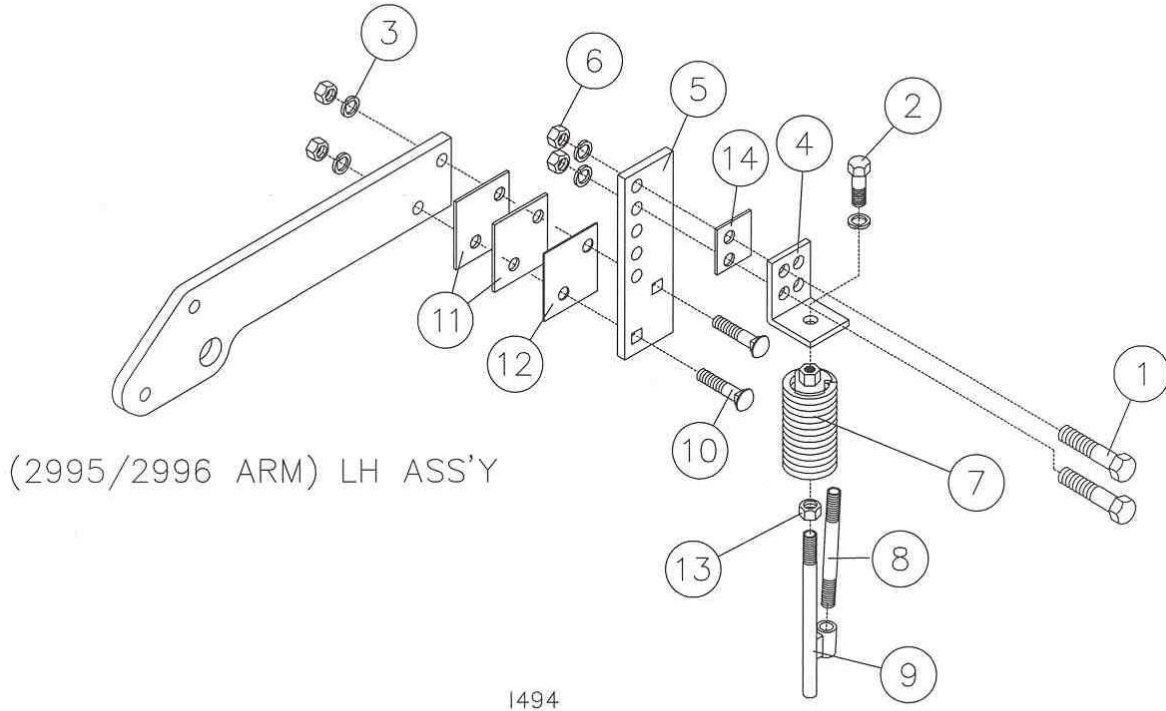

2995-109 SPRING MOUNT LIQ. FERT. INJECTOR KIT

Key	Qty.	Part No.	Description
1	2	2502-294	1/2-13 x 1-1/2 HHCS Gr. 5 ZP
2	1	2502-292	1/2-13 x 1 HHCS Gr. 5 ZP
3	5	2525-352	1/2 Med. Lockwasher ZP
4	1	2995-301	Injector Mount Plate
5	1	2975-389	Adjustment Plate, Injector
6	4	2520-352	1/2-13 Hex Nut ZP
7	1	2995-131	Spring Injector Assembly
8	1	2515-311	3" Nipple, 1/4 NPT Stainless Steel
9	1	2995-212	Injector Rod W.A., 1/2-13
10	2	2502-345	1/2-13 x 2 Car. Bolt Gr. 5 ZP
11	2	2970-319	Knife Shim, 1/8", ZP
12	1	2970-320	Knife Shim, 16 GA., ZP
13	1	2520-356	1/2-13 Jam Hex Nut ZP
14	1	2995-320	Spacer, Injector

PARTS IDENTIFICATION

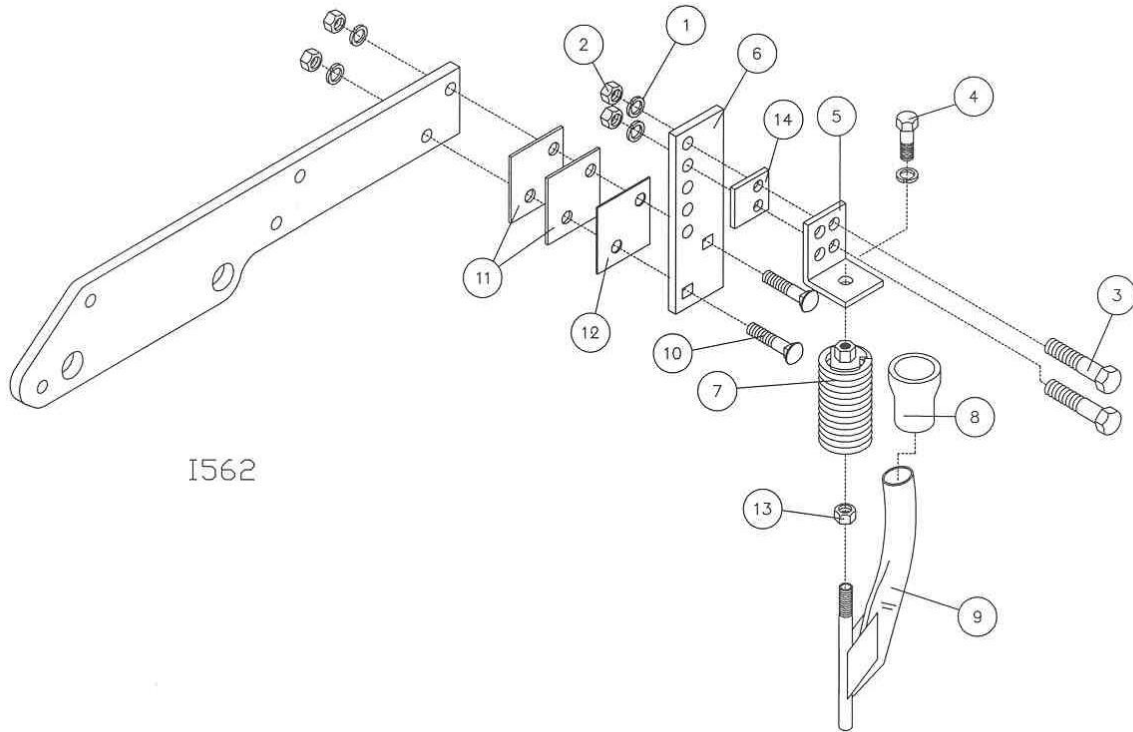

2995-130 SPRING MOUNT DRY INJECTOR KIT

Key	Qty.	Part No.	Description
1	5	2525-352	1/2 Med. Lockwasher ZP
2	4	2520-352	1/2-13 Hex Nut ZP
3	2	2502-294	1/2-13 x 1 1/2 HHCS Gr. 5 ZP
4	1	2502-292	1/2-13 x 1 HHCS Gr. 5 ZP
5	1	2995-301	Injector Mount Plate
6	1	2975-389	Adjustment Plate, Injector
7	1	2995-131	Injector Spring Assembly
8	1	2515-547	Dry Fertilizer Adapter, PVC
9	1	2995-213	Spring Tine Dry Injector W.A.
10	2	2505-345	1/2-13 x 2 Car. Bolt Gr. 5 ZP
11	2	2970-319	Knife Shim, 1/8", ZP
12	1	2970-320	Knife Shim, 16 Ga., ZP
13	1	2520-356	1/2-13 Jam Hex Nut
14	1	2995-320	Spacer, Injector

PARTS IDENTIFICATION

2970-133 17" Knife Scraper

Key	Qty.	Part No.	Description
1	1	2970-353	Double Edge Knife Scraper
2	1	2502-199	5/16-18 x 3/4 HHCS Gr. 5 ZP
3	1	2526-201	5/16 Std. Flatwasher ZP
4	1	2520-205	5/16-18 Lock Hex Nut ZP
5	2	2505-339	1/2 x 1-1/2 Carriage Bolt

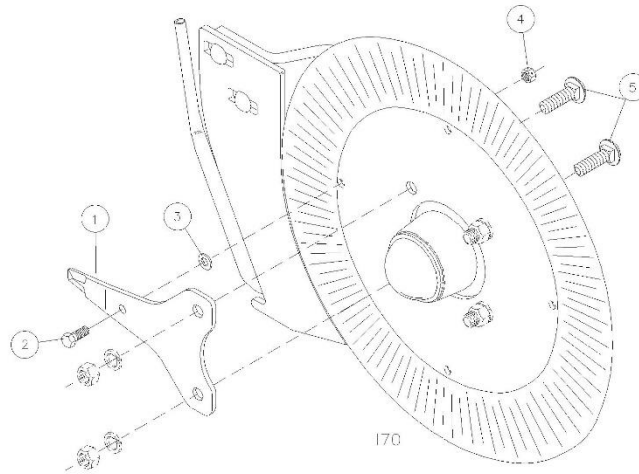

2976-133 20" Knife Scraper

Key	Qty.	Part No.	Description
1	1	2976-353	Double Edge Knife Scraper
2	1	2502-199	5/16-18 x 3/4 HHCS Gr. 5 ZP
3	1	2526-201	5/16 Std. Flatwasher ZP
4	1	2520-205	5/16-18 Lock Hex Nut ZP
5	2	2505-339	1/2 x 1-1/2 Carriage Bolt

DO NOT OVER TIGHTEN.

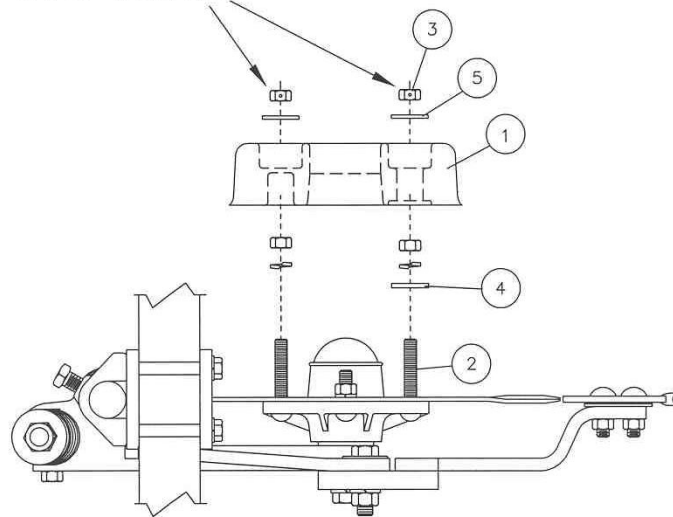

164

2975-120 Gauge Wheel Kit

Key	Qty.	Part No.	Description
1	1	2515-560	Gauge Wheel, 9" x 2-1/2"
1	1	2515-561	Gauge Wheel, 11" x 2-1/2"
2	2	2505-330	1/2-13 x 3 Carriage Blt Gr. 5 ZP
3	2	2520-357	1/2-13 Lock Hex Nut ZP
4	1	2527-330	1/2 ID x 1 1/2 OD x 7 Ga. Ma. Bu. ZP
5	2	2527-340	1/2 ID x 1-1/2 OD x 10 Ga. Ma. Bu. ZP

MAJOR COMPONENTS

Fertilizer Coulter Assembly

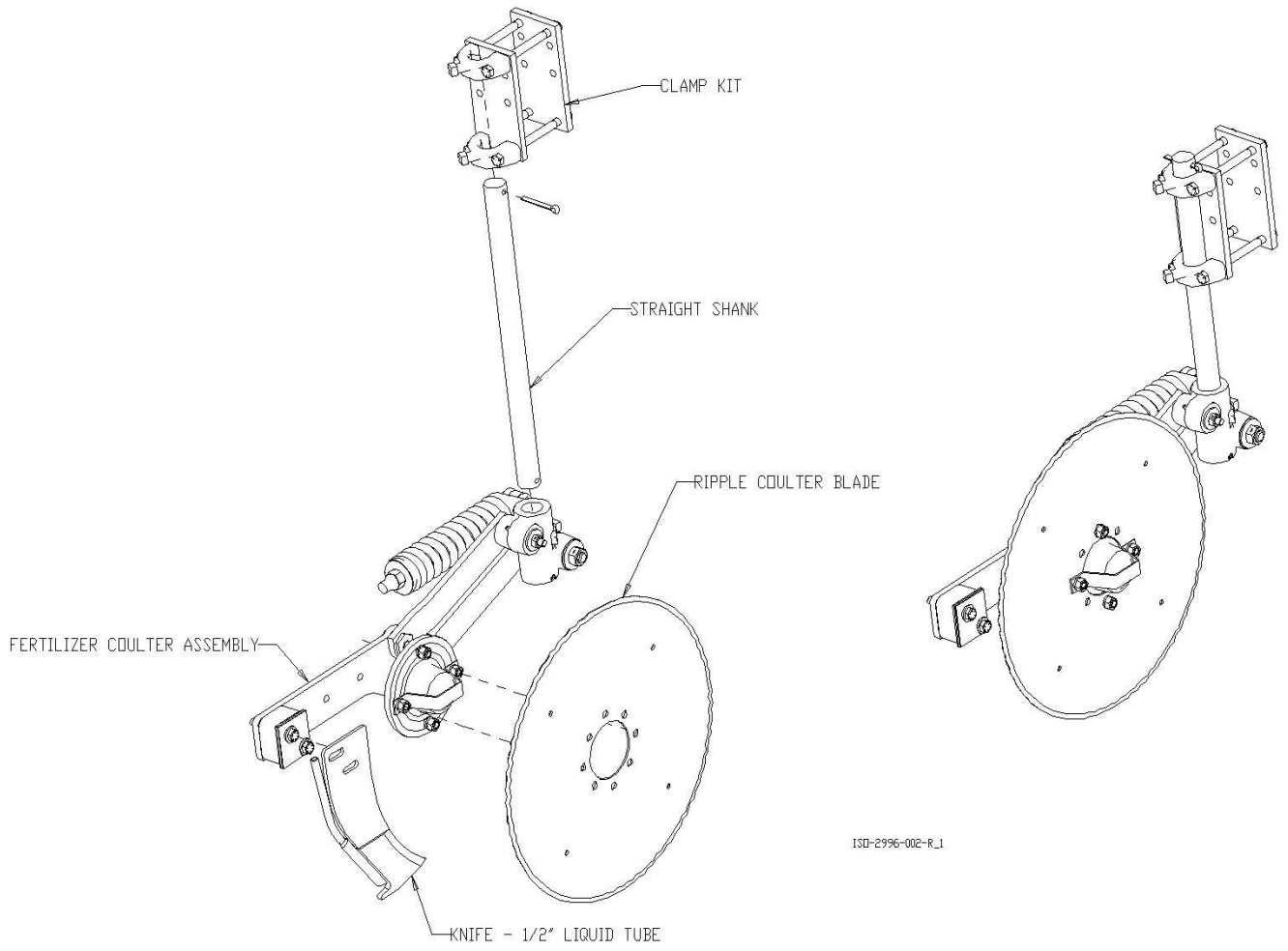

ISD-2996-002-R.1

PARTS IDENTIFICATION

2995 Series 17" Fertilizer Coulter Assembly 2995-065-L

ITEM	PART NO.	DESCRIPTION	QTY
1	2502-358	1/2-13 X 3 1/2 HHCS G8 ZP	2
2	2503-379	5/8-11 X 1 SQ. HCPSS GR5ZP	1
3	2505-337	1/2-13 X 1 1/4 CARBLT G5ZP	4
4	2520-352	1/2-13 HEX NUT ZP	4
5	2520-362	1/2-13 HEX LOK NUT, GR C, ZP	2
6	2525-352	1/2 MED LOCKWASHER ZP.	4
7	2526-355	1/2 FLAT WASHER HARD'ND ZP	2
8	2530-208	3/8 X 2-1/2 ROLL PIN ZP	1
9	2531-161	COTTER PINS	1
10	2970-319	KNIFE SHIM, 1/8", ALUMINUM	2
11	2970-320	KNIFE SHIM, 16 GA., ALUMINUM	1
12	2975-220	LIQUID FERT KNIFE .5" TUBE	1
13	2975-303	2975 LOCKING COLLAR	1
14	2987-301	HUB CAP RETAINER	1
15	2995-102-L	LH 17" FERTILIZER CLTR. ASS'Y	1
16	2995-309	SPACER BLOCK	1

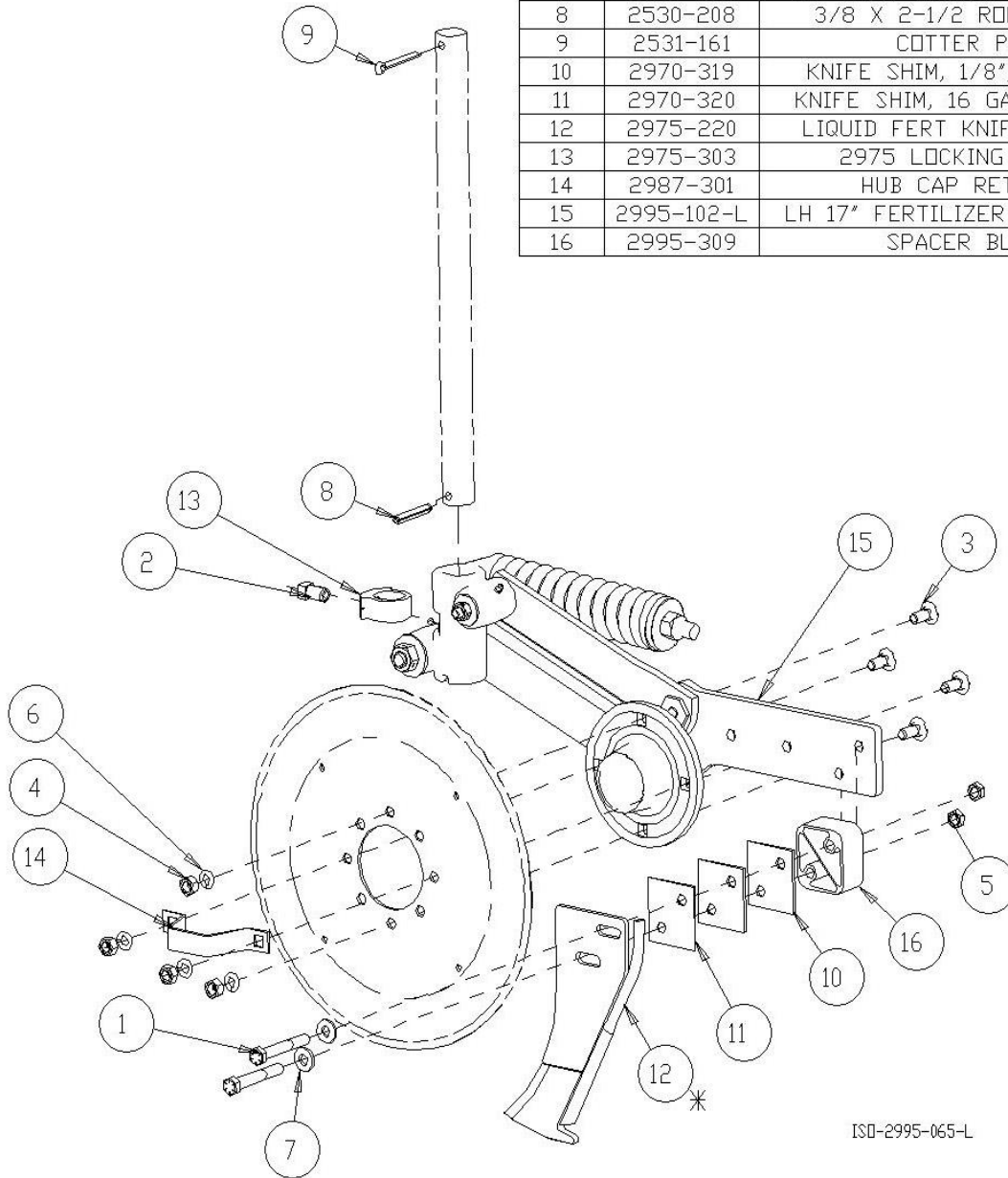

***ALTERNATE COMPONENTS (not shown):**

ITEM	PART NO.	DESCRIPTION	QTY.
12	2975-232	DRY FERTILIZER KNIFE – 1.50" TUBE	1
-	2515-547	ADAPTER 1.500ID-2.188 OD	1

PARTS IDENTIFICATION

2995 Series 17" Fertilizer Coulter Assembly 2995-102-L

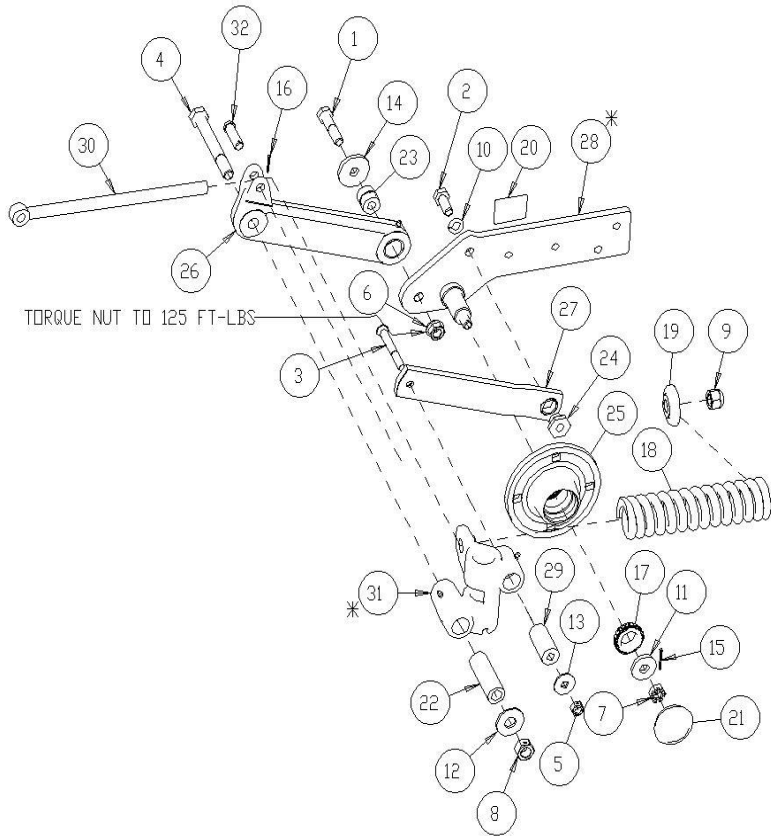

TORQUE NUT TO 125 FT-LBS

ITEM	PART NO.	DESCRIPTION	QTY.
1	2502-323	5/8-11 X 2-3/4 HHCS GR 5 ZP	1
2	2502-339	5/8-18 X 1 1/2 HHCS GR5 ZP	1
3	2502-360	1/2-13 X 4 HSFHCS	1
4	2502-510	3/4-10 X 6 HHCS GR.5 ZP	1
5	2520-357	1/2-13 LOCK HEX NUT, GR A, ZP	1
6	2520-464	5/8-11 WHIZLOCK HEX NUT, GR 2, ZP	1
7	2520-469	5/8-18 SLOTTED HEX NUT,PLAIN, GR2	1
8	2520-515	3/4-10 LOCK HEX NUT, GR A, ZP	1
9	2520-516	3/4-10 NYLON INSERT LCKNT, GR 2, ZP	1
10	2525-451	5/8 MED. LOCKWASHER ZP.	1
11	2526-449	5/8 FLATWASHER 1/4 +-0.010 THK, ZP	1
12	2526-501	3/4 STANDARD FLATWASHER ZP	1
13	2527-340	1/2IDX1 1/2DD X 10 GA MA BU	1
14	2527-529	21/32ID X 2 1/4DD X 1/4*MABU	1
15	2531-102	1/8 X 1-1/4 COTTER PIN, PLAIN	1
16	2531-107	1/8 X 1 COTTER PIN ZP	1
17	2550-027	CONE, LM67048, KOYO	1
18	2550-795	SPRING, .562" WIRE X 11" LONG	1
19	2975-302	SPRING BUSHING CASTING	1
20	2565-682	YETTER/PAT. PEND./ADJ. DECAL	1
21	2570-375	HUB CAP, WILTON #909902	1
22	2570-704	PIVOT SLEEVE	1
23	2570-761	LOWER ARM PIVOT	1
24	2570-762	UPPER ARM PIVOT/WASHER ZP	1
25	2900-102	HUB SUB-ASSEMBLY	1
26	2995-110	LOWER COULTER ARM ASSEMBLY	1
27	2995-111	UPPER COULTER ARM ASSEMBLY	1
28	2995-206	LH KNIFE ARM PLATE/SPINDLE WA	1
29	2995-303	PIVOT SLEEVE, 2 19/32"	1
30	2995-304	SPRING ROD, 13 1/2"	1
31	2995-306	COULTER PIVOT, LH	1
32	2995-308	SPRING ROD PIN	1

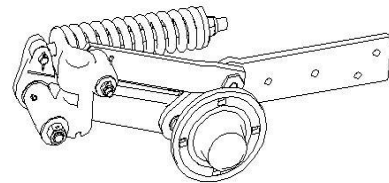

ISO-2995-102-L

***ALTERNATE COMPONENTS (not shown):**

ITEM	PART NO.	DESCRIPTION	QTY.
26	2995-110	LOWER COULTER ARM ASSEMBLY	1
-	2528-362	BUSHING 1.25"ID X 1.50"OD X 1.25 WIDE	1
-	2533-110	GREASE FITTING 1/4-28 SELF TAP	1
27	2995-111	UPPER COULTER ARM ASSEMBLY	1
-	2528-360	BRONZE BUSHING 1" ID X 1.25" OD X .50" WIDE	1
28	2995-207	RH KNIFE ARM	1
31	2995-307	COULTER PIVOT RH	1

PARTS IDENTIFICATION

2996 Series 20" Fertilizer Coulter Assembly 2996-002-R

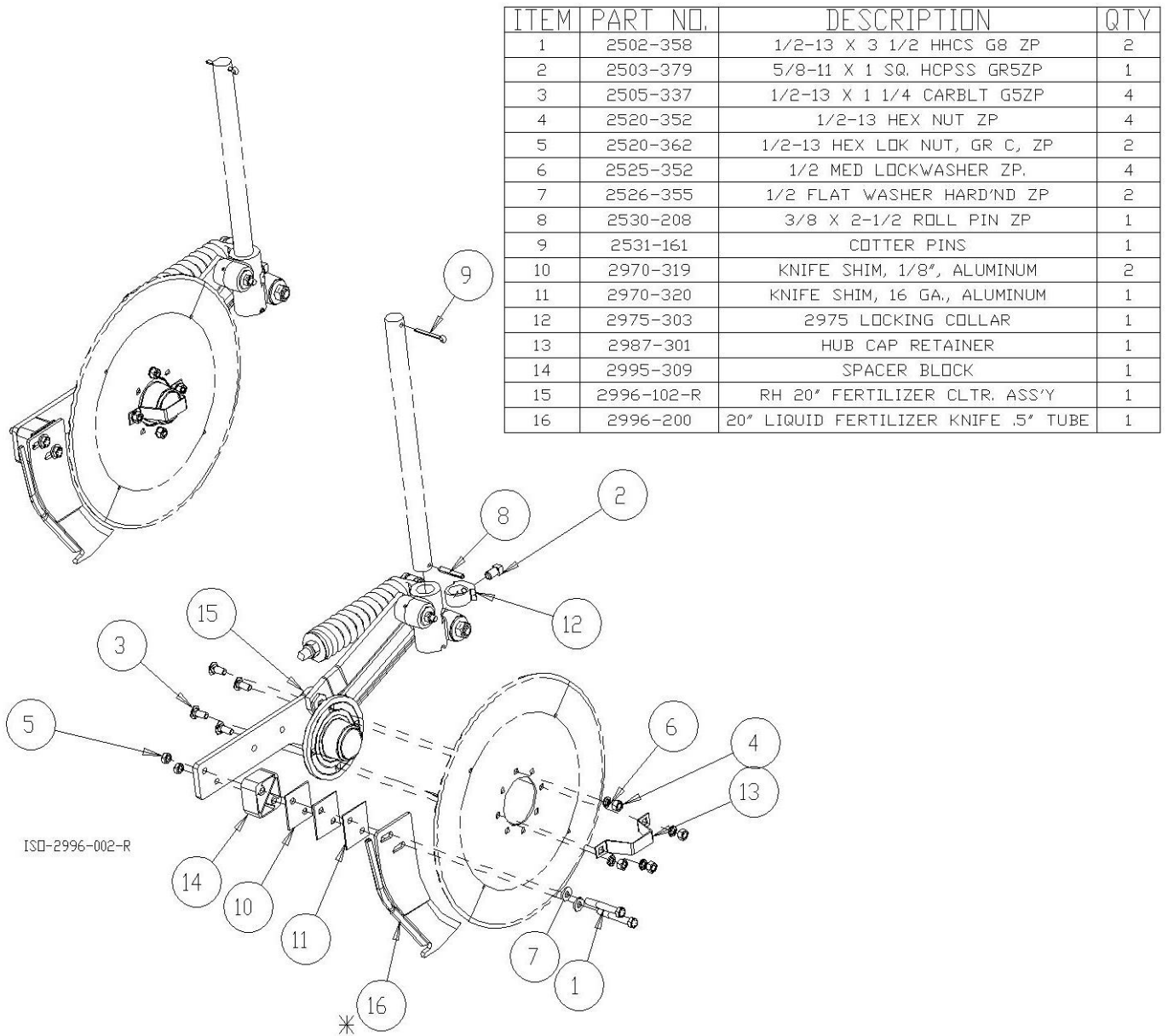

ITEM	PART NO.	DESCRIPTION	QTY
1	2502-358	1/2-13 X 3 1/2 HHCS G8 ZP	2
2	2503-379	5/8-11 X 1 SQ. HCPSS GR5ZP	1
3	2505-337	1/2-13 X 1 1/4 CARBLT G5ZP	4
4	2520-352	1/2-13 HEX NUT ZP	4
5	2520-362	1/2-13 HEX LOK NUT, GR C, ZP	2
6	2525-352	1/2 MED LOCKWASHER ZP.	4
7	2526-355	1/2 FLAT WASHER HARD'ND ZP	2
8	2530-208	3/8 X 2-1/2 ROLL PIN ZP	1
9	2531-161	COTTER PINS	1
10	2970-319	KNIFE SHIM, 1/8", ALUMINUM	2
11	2970-320	KNIFE SHIM, 16 GA., ALUMINUM	1
12	2975-303	2975 LOCKING COLLAR	1
13	2987-301	HUB CAP RETAINER	1
14	2995-309	SPACER BLOCK	1
15	2996-102-R	RH 20" FERTILIZER CLTR. ASS'Y	1
16	2996-200	20" LIQUID FERTILIZER KNIFE .5" TUBE	1

***ALTERNATE COMPONENTS (not shown):**

ITEM	PART NO.	DESCRIPTION	QTY.
16	2996-201	DRY KNIFE 1.50" TUBE	1
-	2515-547	ADAPTER 1.500" – 2.188"	1
16	2996-210	LIQUID KNIFE .50" TUBE	1

PARTS IDENTIFICATION

2996 Series 20" Fertilizer Coulter Assembly 2996-102-R

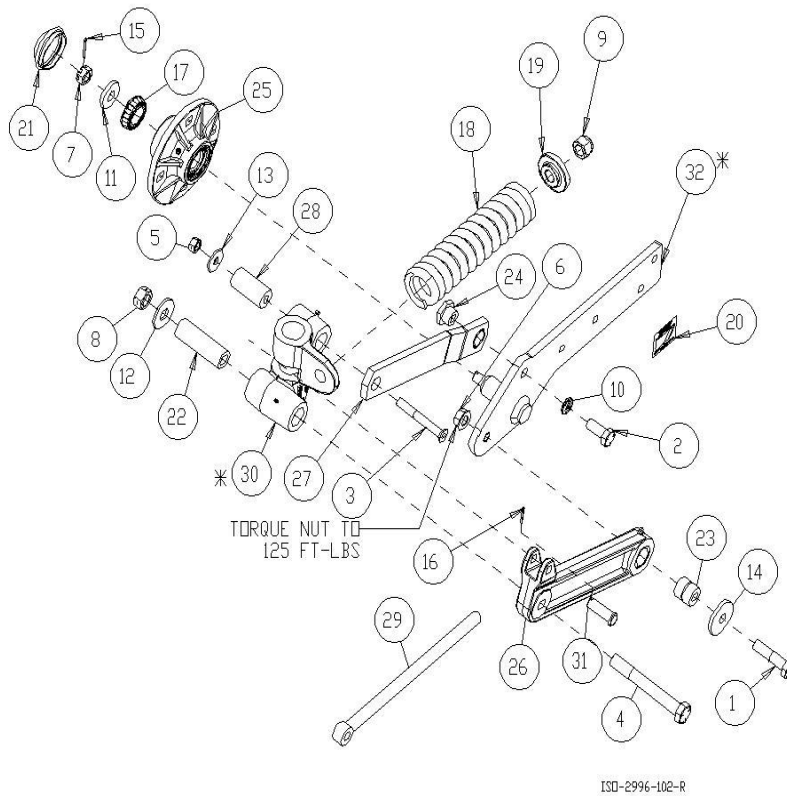

ITEM	PART NO.	DESCRIPTION	QTY
1	2502-323	5/8-11 X 2-3/4 HHCS GR 5 ZP	1
2	2502-339	5/8-18 X 1 1/2 HHCS GR5 ZP	1
3	2502-360	1/2-13 X 4 HSFHCS	1
4	2502-510	3/4-10 X 6 HHCS GR.5 ZP	1
5	2520-357	1/2-13 LOCK HEX NUT, GR A, ZP	1
6	2520-464	5/8-11 WHIZLOCK HEX NUT, GR 2, ZP	1
7	2520-469	5/8-18 SLOTTED HEX NUT BLK, GR 2	1
8	2520-515	3/4-10 LOCK HEX NUT, GR A, ZP	1
9	2520-516	3/4-10 NYLON INSERT LCKNT, GR 2, ZP	1
10	2525-451	5/8 MED. LOCKWASHER ZP.	1
11	2526-449	5/8 FLATWASHER 1/4 +-010 THK, ZP	1
12	2526-501	3/4 STANDARD FLATWASHER ZP	1
13	2527-340	1/2IDX1 1/2OD X 10 GA MA BU	1
14	2527-529	21/32ID X 2 1/4OD X 1/4" MABU	1
15	2531-102	1/8 X 1-1/4 COTTER PIN, PLAIN	1
16	2531-107	1/8 X 1 COTTER PIN ZP	1
17	2550-027	CDNE, LM67048, KOYO	1
18	2550-795	SPRING, .562" WIRE X 11" LONG	1
19	2975-302	SPRING BUSHING CASTING	1
20	2565-682	YETTER/PAT. PEND./ADJ. DECAL	1
21	2570-375	HUB CAP, WILTON #909902	1
22	2570-704	PIVOT SLEEVE	1
23	2570-761	LOWER ARM PIVOT	1
24	2570-762	UPPER ARM PIVOT/WASHER ZP	1
25	2900-102	HUB SUB-ASSEMBLY	1
26	2995-110	LOWER COULTER ARM ASSEMBLY	1
27	2995-111	UPPER COULTER ARM ASSEMBLY	1
28	2995-303	PIVOT SLEEVE, 2 19/32"	1
29	2995-304	SPRING ROD, 13 1/2"	1
30	2995-307	COULTER PIVOT, RH	1
31	2995-308	SPRING ROD PIN	1
32	2996-205	RH 2996 KNIFE ARM/SPINDLE W.A.	1

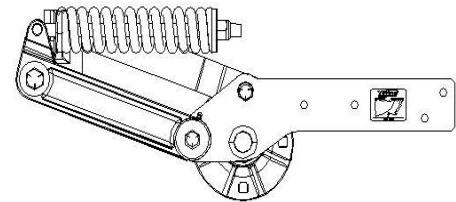

***ALTERNATE COMPONENTS (not shown):**

ITEM	PART NO.	DESCRIPTION	QTY.
26	2995-110	LOWER COULTER ARM ASSEMBLY	1
-	2528-362	BUSHING 1.25"ID X 1.50"OD X 1.25 WIDE	1
-	2533-110	GREASE FITTING 1/4-28 SELF TAP	1
27	2995-111	UPPER COULTER ARM ASSEMBLY	1
-	2528-360	BRONZE BUSHING 1" ID X 1.25" OD X .50" WIDE	1
30	2996-306	COULTER PIVOT - LH	1
32	2996-204	LH KNIFE ARM	1

PARTS IDENTIFICATION

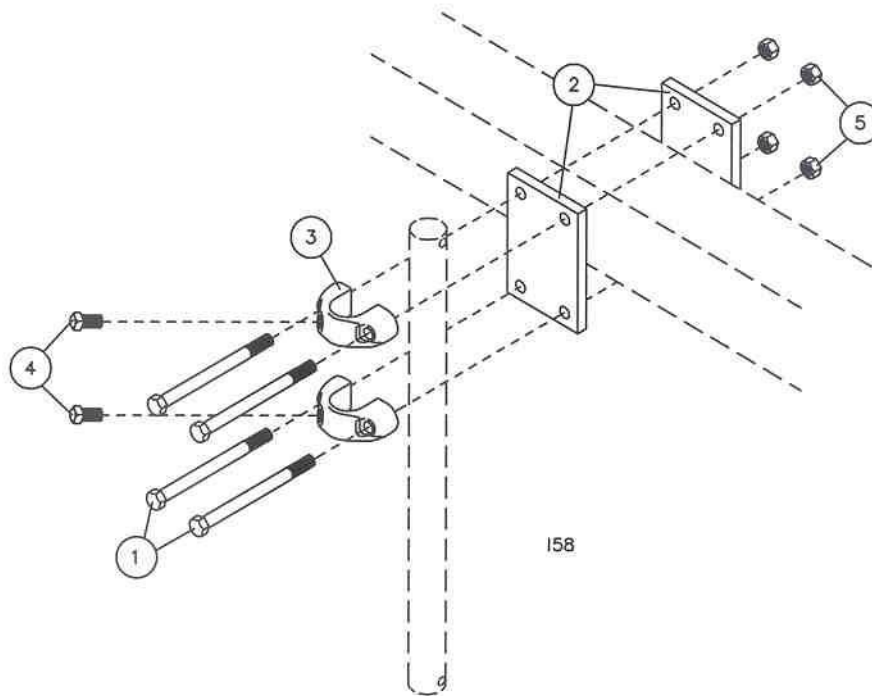

2990-154 Clamp Kit, 2-1/2" Sq. Bar

Key	Qty.	Part No.	Description
1	4	2502-368	1/2-13 x 5-1/2" HHCS GR. 5 ZP
2	2	2990-313	Clamp Plate, 2-1/2 Square Bar
3	2	2990-360	Clamp Casting, Drilled
4	2	2503-379	5/8-11 x 1 Sq. HCPSS Gr. 5 ZP
5	4	2520-357	1/2-13 Hex Lock Nut ZP

2990-155 Clamp Kit, 2 x 6 Bar

Key	Qty.	Part No.	Description
1	4	2502-362	1/2-13 X 5" HHCS GR. 5 ZP
2	2	2990-363	Clamp Plate, 2 x 6 Bar
3	2	2990-360	Clamp Casting, Drilled
4	2	2503-379	5/8-11 x 1 Sq. HCPSS Gr. 5 ZP
5	4	2520-357	1/2-13 Hex Lock Nut ZP

2990-156 Clamp Kit, 4 x 4 Bar

Key	Qty.	Part No.	Description
1	4	2502-371	1/2-13 x 7" HHCS GR. 5 ZP
2	2	2990-314	Clamp Plate, 4" Sq. & 3" Diamond Bar
3	2	2990-360	Clamp Casting, Drilled
4	2	2503-379	5/8-11 x 1 Sq. HCPSS Gr. 5 ZP
5	4	2520-357	1/2-13 Hex Lock Nut ZP

2990-157 Clamp Kit, 5 x 7 Bar

Key	Qty.	Part No.	Description
1	4	2502-369	1/2-13 X 8" HHCS GR. 5 ZP
2	2	2990-315	Clamp Plate, 5 x 7 or 7 x 7 Bar
3	2	2990-360	Clamp Casting, Drilled
4	2	2503-379	5/8-11 x 1 Sq. HCPSS Gr. 5 ZP
5	4	2520-357	1/2-13 Hex Lock Nut ZP

2990-158 Clamp Kit, 7 x 7 Bar

Key	Qty.	Part No.	Description
1	4	2502-376	1/2-13 x 10" HHCS GR. 5 ZP
2	2	2990-315	Clamp Plate, 5 x 7 or 7 x 7 Bar
3	2	2990-360	Clamp Casting, Drilled
4	2	2503-379	5/8-11 x 1 Sq. HCPSS Gr. 5 ZP
5	4	2520-357	1/2-13 Hex Lock Nut ZP

2990-161 Clamp Kit, 3 x 7 Bar

Key	Qty.	Part No.	Description
1	4	2502-373	1/2-13 X 6" HHCS GR. 5 ZP
2	2	2990-315	Clamp Plate, 5 x 7 or 7 x 7 Bar
3	2	2990-360	Clamp Casting, Drilled
4	2	2503-379	5/8-11 x 1 Sq. HCPSS Gr. 5 ZP
5	4	2520-357	1/2-13 Hex Lock Nut ZP"

2990-163 Clamp Kit, 3 x 3 Bar

Key	Qty.	Part No.	Description
1	4	2502-373	1/2-13 x 6" HHCS GR. 5 ZP
2	2	2990-339	Clamp Plate, 3" Square Bar
3	2	2990-360	Clamp Casting, Drilled
4	2	2503-379	5/8-11 x 1 Sq. HCPSS Gr. 5 ZP
5	4	2520-357	1/2-13 Hex Lock Nut ZP

2990-171 Clamp Kit, 3 x 4 Bar

Key	Qty.	Part No.	Description
1	4	2502-373	1/2-13 X 6" HHCS GR. 5 ZP
2	2	2990-314	Clamp Plate, 4" Sq. & 3" Dmd Bar
3	2	2990-360	Clamp Casting, Drilled
4	2	2503-379	5/8-11 x 1 Sq. HCPSS Gr. 5 ZP
5	4	2520-357	1/2-13 Hex Lock Nut ZP

PARTS IDENTIFICATION

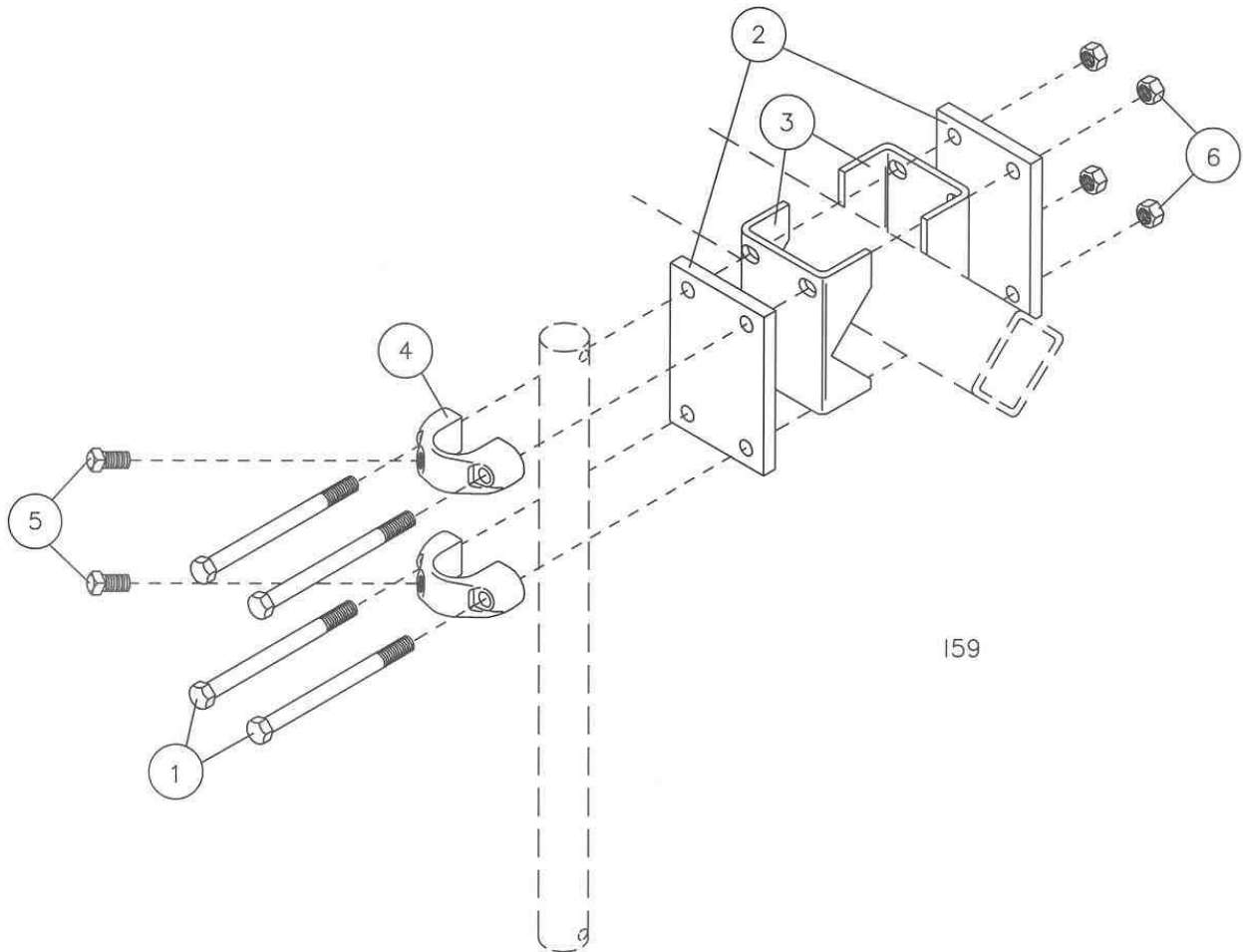

159

2990-159 Clamp Kit, 3" Diamond Bar

Key	Qty.	Part No.	Description
1	4	2502-369	1/2-13 x 8" HHCS Gr. 5 ZP
2	2	2990-314	Clamp Plate, 4" Sq. or 3" Diamond
3	2	2970-326	Adaptor, 3" Sq. Diamond Bar
4	2	2990-360	Clamp Casting, Drilled
5	2	2503-379	5/8-11 x 1" Sq. HCPSS Gr. 5 ZP
6	4	2520-357	1/2-13 Lock Hex Nut ZP

2990-160 Clamp Kit, 3-1/2" Diamond Bar

Key	Qty.	Part No.	Description
1	4	2502-374	1/2-13 x 9" HHCS Gr. 5 ZP
2	2	2990-316	Clamp Plate, 3-1/2" Diamond Bar
3	2	2970-327	Adaptor, 3-1/2" Sq. Diamond Bar
4	2	2990-360	Clamp Casting, Drilled
5	2	2503-379	5/8-11 x 1" Sq. HCPSS Gr. 5 ZP
6	4	2520-357	1/2-13 Lock Hex Nut ZP

TROUBLESHOOTING

<i>Problem</i>	<i>Cause</i>	<i>Solution</i>
Setting coulter	Planter not set correctly	Ensure that in operation the planter frame is at correct height (20"-22") and level the toolbar. See opposite page.
Trash plugging	Excessive knife-blade clearance	Check and adjust knife-blade clearance. See page 7.
	Knife not correctly aligned behind blade	Use shims to align knife behind blade
Blade not penetrating	Insufficient coulter spring pressure	Tighten coulter spring locknut down 1" further
	Coulter incorrectly installed	Adjust height of coulter by sliding shank down
Spring not deflecting	Excessive spring pressure	Back off coulter spring locknut to 1/8" of thread exposed
Fertilizer too deep	Spring not deflecting	Back off coulter spring locknut to 1/8" of thread exposed
	Coulter incorrectly installed	Adjust height of coulter by sliding shank up
	Lack of depth control	Install gauge wheel kit, part no. 2975-120
	Planter frame too low	Raise planter frame to correct height
Fertilizer too shallow	Blade not penetrating	Tighten coulter spring locknut down 1" further
	Coulter incorrectly installed	Adjust height of coulter by sliding shank down
	Incorrect depth control	Install gauge wheel kit, part no. 2975-120
Fertilizer will not flow	Plugged fertilizer tubes	Check for plugged fertilizer tube openings on knife Check for plugged fertilizer delivery tubes on planter
Blade not rotating properly	Loose soil	Coulter works best in firmer soil conditions

PLANTER HEIGHT ADJUSTMENT

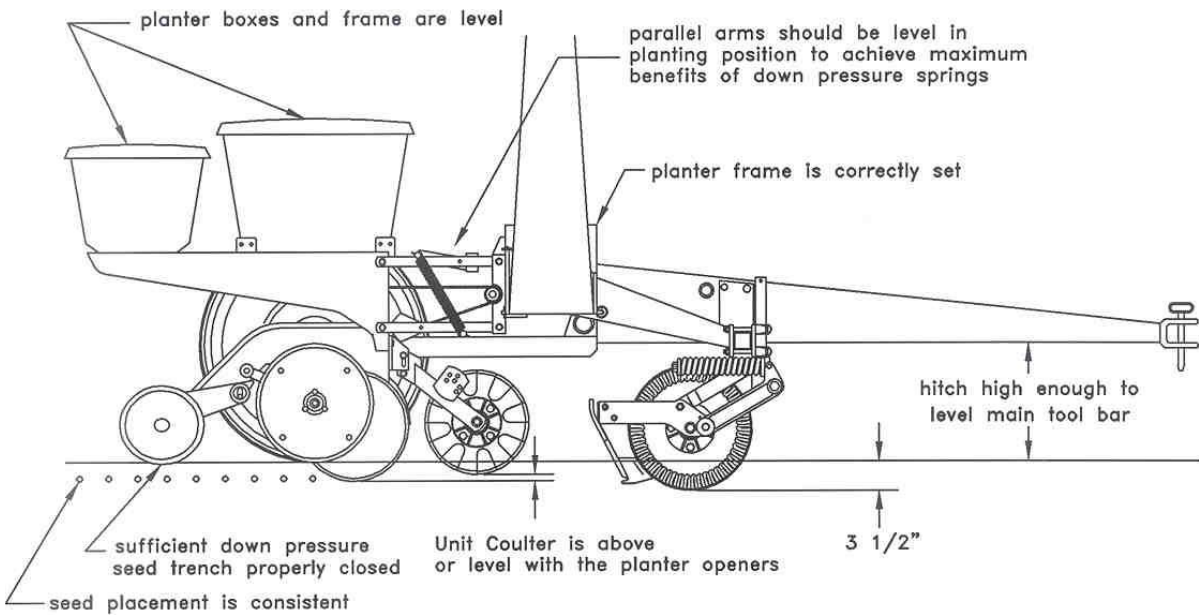

FIGURE A. (CORRECT)

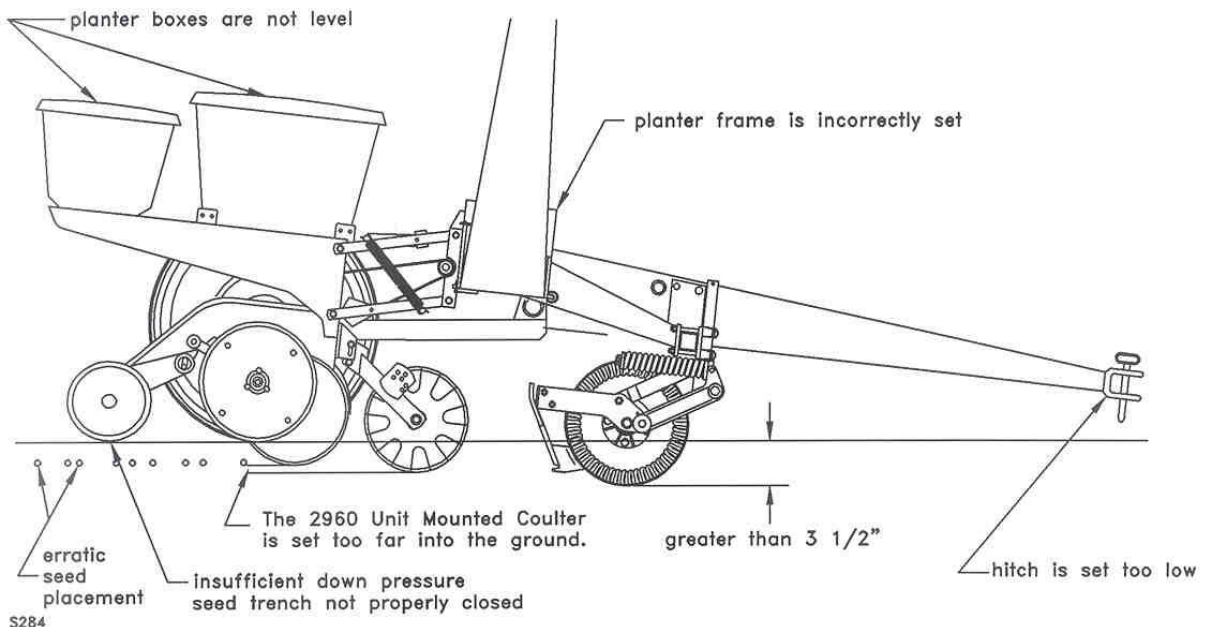

FIGURE B. (INCORRECT)

Figure A. – The planter hitch and frame are both 20" of the ground. To ensure this, visually check to see that the planter boxes are level and that the planter unit parallel arms are also parallel with the ground. **When using planter attachments located in front of the planter unit, this setting is very important.**

Figure B. – The planter hitch is set too low while the planter frame remains at 20" off the ground! Notice from the illustration that the fertilizer coulters are running below desired depth.

NOTE – Both illustrations are strictly for reference only. They are intended to show that proper adjustment of the hitch height is critical. Consult your planter operator's manual for the proper height adjustment of the hitch.

NOTES:

Our name Is getting known

Just a few years ago, Yetter products were sold primarily to the Midwest only. Then we embarked on a program of expansion and moved into the East, the South, the West and now north into Canada. We're even getting orders from as far away as Australia and Africa.

So, when you buy Yetter products . . .you're buying a name that's recognized. A name that's known and respected. A name that's become a part of American agriculture and has become synonymous with quality and satisfaction in the field of conservation tillage.

Thank you.

YETTER MANUFACTURING CO.

Colchester, IL 62326-0358 • 309/776-4111

Toll Free 800/447-5777

Fax 309/776-3222

Website: WWW.YETTERCO.COM

E-mail: INFO@YETTECO.COM

2565-369_REV_F • 02/19