

**BD**  
**BK**  
**BCIH**

# **1360 ROW CLEANER**

## **INSTALLATION INSTRUCTIONS**

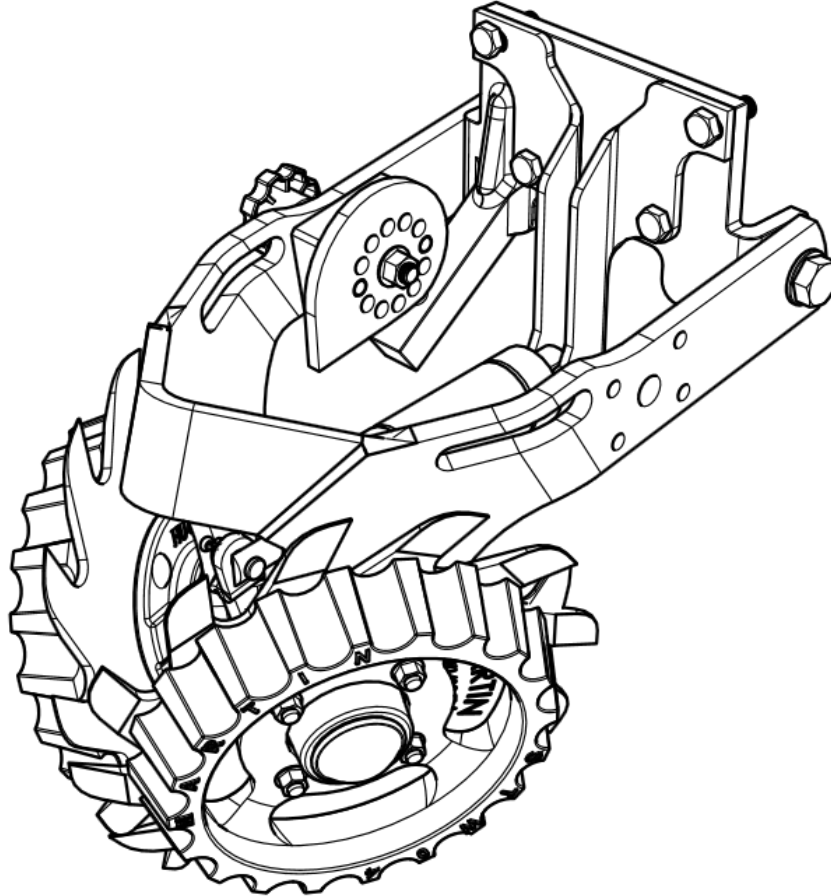

**SHOWN WITH BD MOUNT AND OPTIONAL  
SIDE TREADER WHEELS , CAM ADJUST, SMART CLEAN CYLINDER AND BRACKETS AND  
RAZOR WHEELS**



**Martin Industries LLC**

206 Elk Fork Road

Elkton, KY 42220

Telephone: 270-265-5817

E-Mail: [martin@martintill.com](mailto:martin@martintill.com)

[www.martintill.com](http://www.martintill.com)



## STEP 1 : ATTACH THE MOUNT TO THE PLANTER

Using four 1/2" X 1 1/2" bolts, attach the mount to the planter face plate, and torque mounting nuts to 57 ft-lbs.

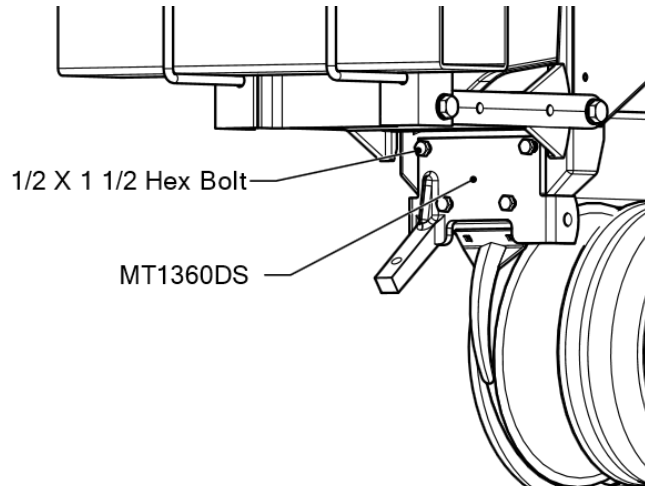

If you purchased the optional SmartClean System, install the SmartClean cylinder top brackets on the mount (as shown in the picture) before attaching the mount to the planter. You have received 1/4" longer bolts in this case.

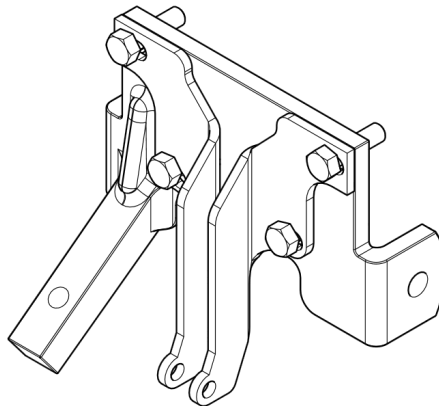

Some of the SmartClean bracket sets (top and bottom brackets) are shown below . Use the instructions in Step 5 to install the bottom brackets.

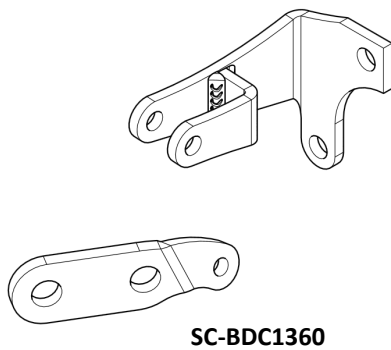

SC-BDC1360

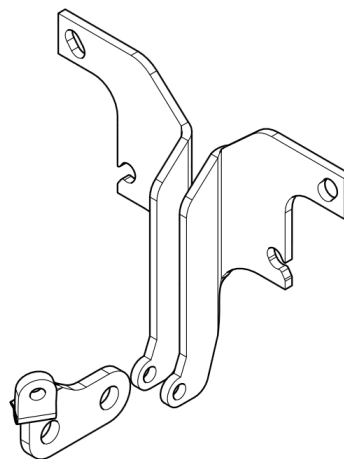

SC-BKW1360

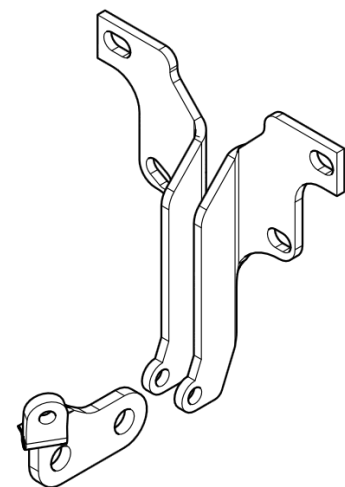

SC-BD1360

## FOR CASEIH 1200 SERIES PLANTERS (BCIH 1360)

Attach the Right and Left L shape brackets ( CIH1360R & CIH1360L) using provided two 1/2" X 3 1/2" Grade 8 bolts and nuts as shown in the picture. Torque to 80 ft-lbs. Using four 1/2" X 1 1/2 " bolts, attach the mount to the L shape brackets, and torque mounting nuts to 57 ft-lbs.

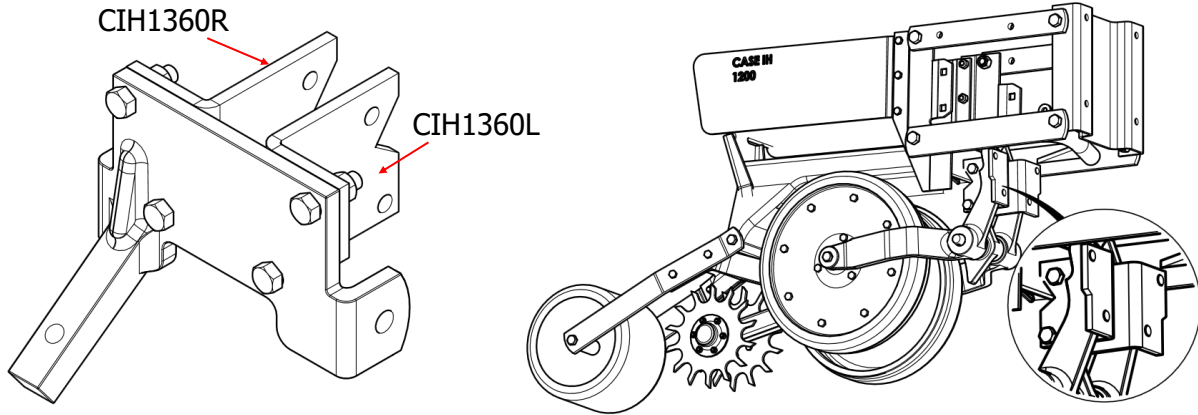

## FOR PLANTERS WITH A UNIT MOUNTED NO-TILL COULTER ( BDC1360, BKC1360 & BK4C)

Planters with a unit mounted no-till coulters require a two-piece mount. Using 1/2" X 2" bolts, attach the right and left mount pieces on the coulters frame and torque mounting nuts to 57ft-lbs. SmartClean top bracket comes in one piece and is attached to the top of the left mount piece with 1/4" longer bolts.

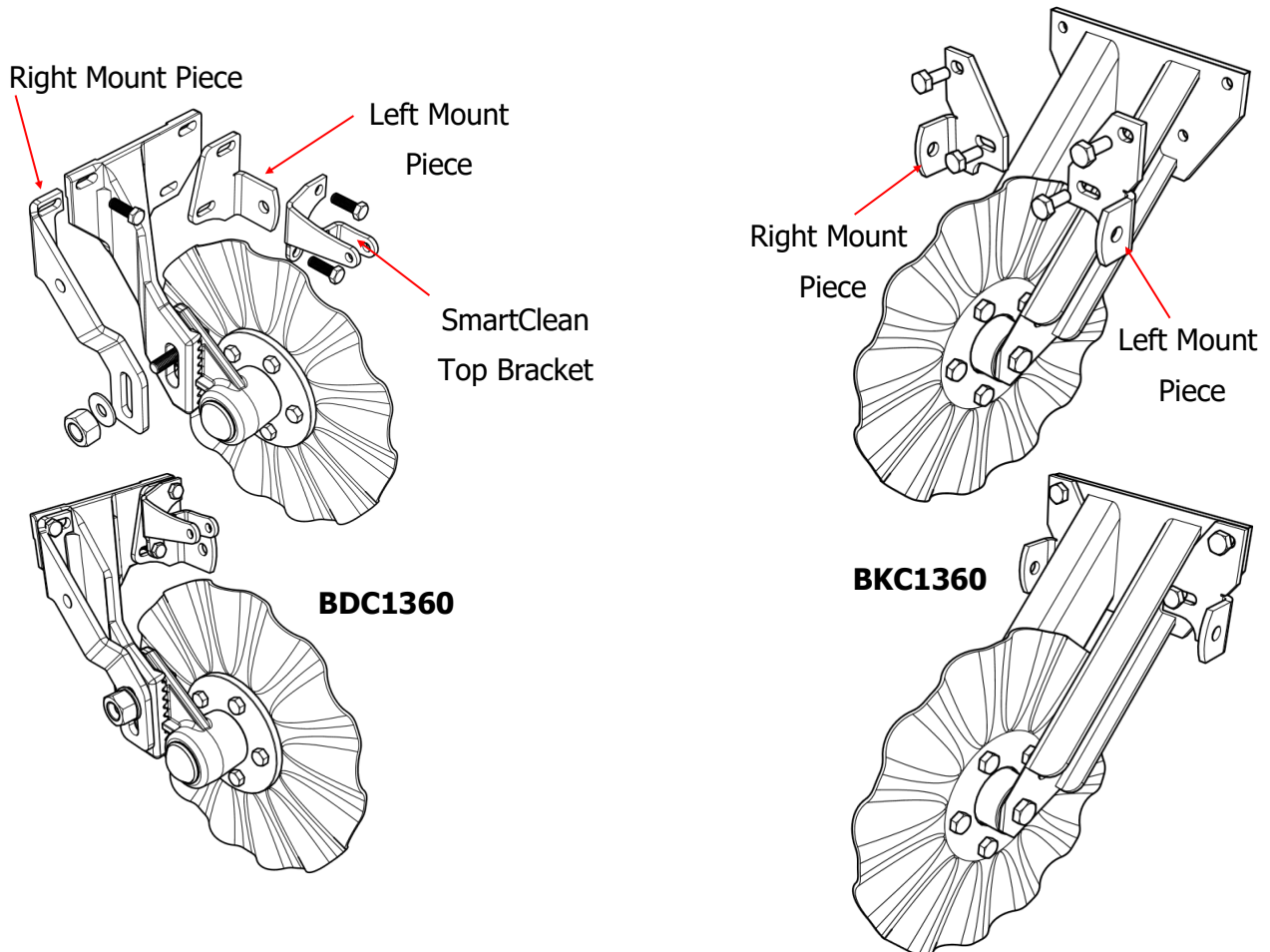

## STEP 2: ATTACH 1360 FRAME ASSEMBLY TO THE MOUNT

1. Place the bushings (BU7858) inside the pin point holes of each frame arm.
2. Align the holes in the mount and the frame assembly. Insert the 5/8" x 2" bolts and washers (you have not received washers if you are provided with flange bolts instead of HEX bolts ) from the outside and place nuts on the 5/8" x 2" bolts from inside.
3. Tighten the bolts to 112 ft-lbs. Check after first day of use.
4. Check to ensure the frame is not binding on the mounting bracket and is free to float up and down.

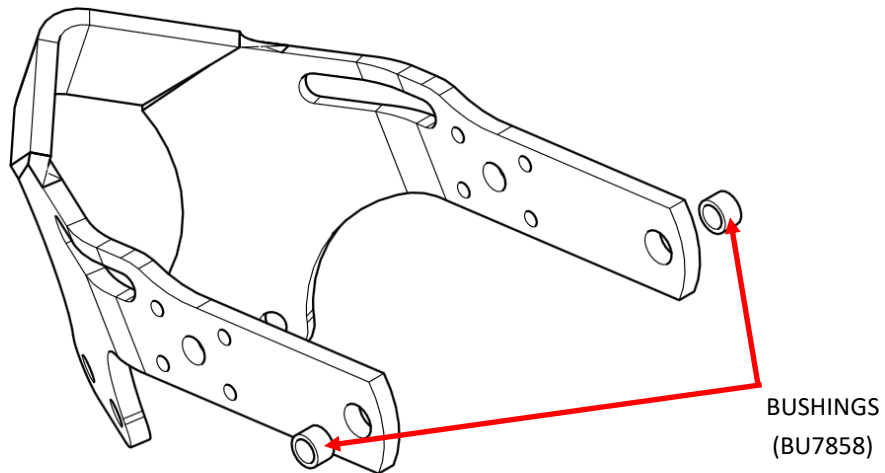

### Note :

Normally the mount is installed inside the frame arms (as shown in the left picture). In some assemblies, (such as BKC 1360 and BK4C 1360), the mount is wide and the frame is installed inside the mount (as shown in the right picture).

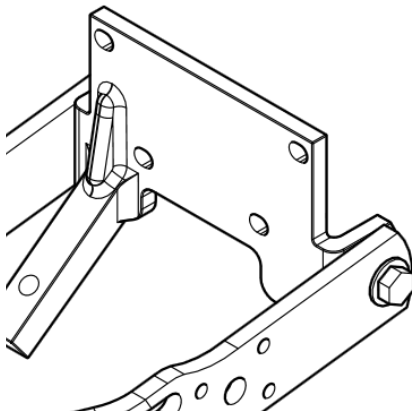

Mount inside the frame arms

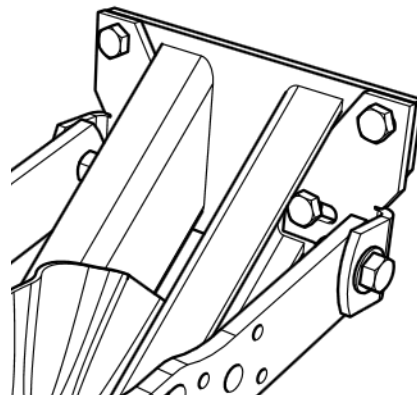

Frame arms inside the mount

## STEP 3: INSTALL THREADED ADJUSTMENT ASSEMBLY

**IMPORTANT:** Skip to [Step 3A](#) if optional cam adjust was purchased

1. Place the adjustment assembly against the frame as shown in diagram below.
2. Secure the adjustment assembly to the frame using the four button head screws and nuts provided.
3. Put the 1/2" nut on the 1/2" x 4" bolt and thread the bolt into the tapped hole of the adjustment assembly. Use the 1/2" nut to lock the 4" adjustment bolt in place once the desired minimum depth setting has been determined.

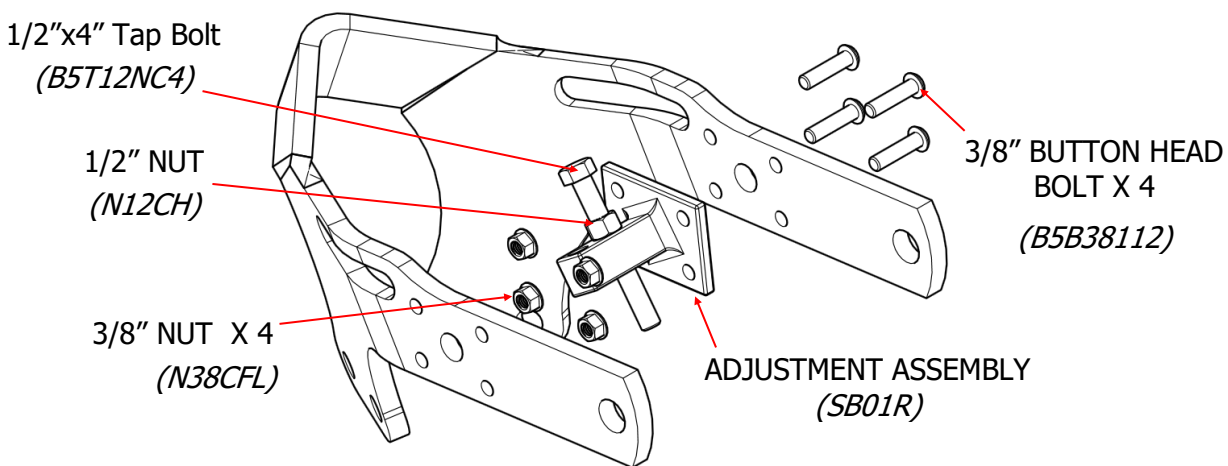

## STEP 3A: INSTALL THE OPTIONAL CAM ADJUSTMENT ASSEMBLY

1. Mount the cam block to the frame using the four 3/8" button head bolts.
2. Slide the 1/2" x 4" bolt through the knob, spring, and support block and thread it into the cam.
3. Tighten the bolt until the cam is directly against the support block but still loose enough to be disengaged from the pin by pushing on the knob.
4. Install the 1/2" nut on the end of the bolt and tighten securely against the cam. Torque to 57 ft-lbs.

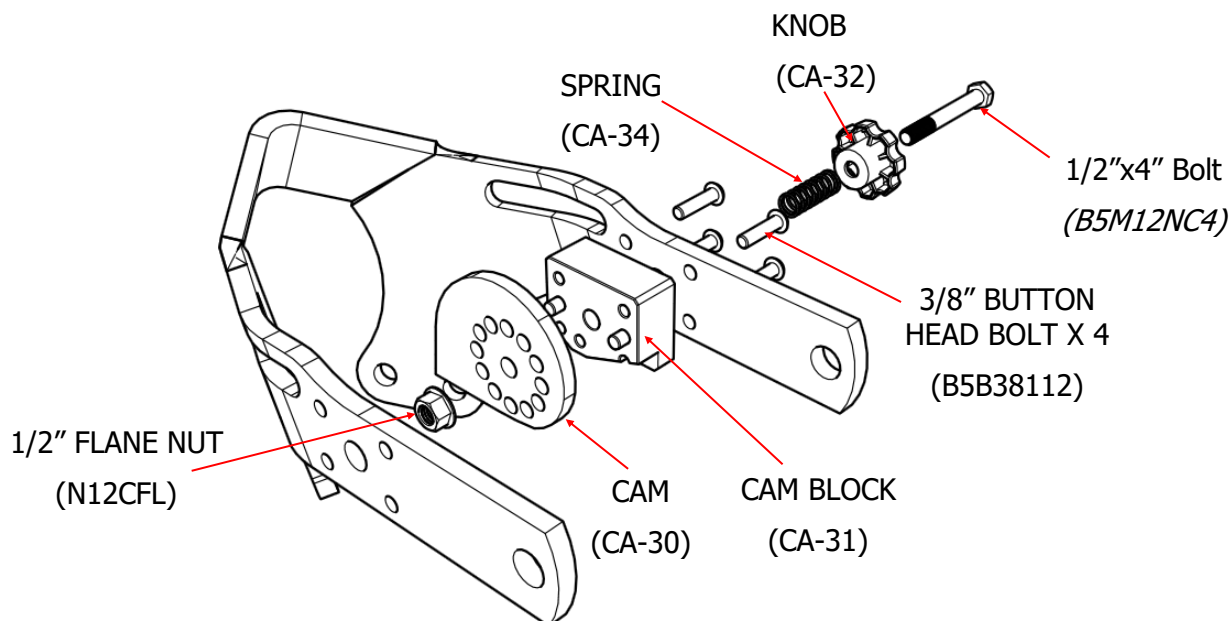

## STEP 4 : DETERMINE THE BEST WHEEL CONFIGURATION FOR YOUR SOIL CONDITIONS

### OPTION A: INTERSECTED

(Both wheels in front hole)

Both wheels forward provides maximum cleaning effect. The interlocked wheels till the middle of the seed row.

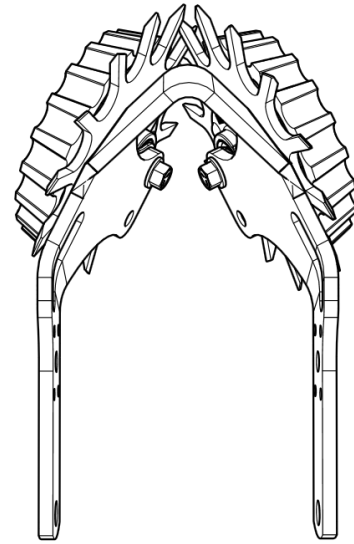
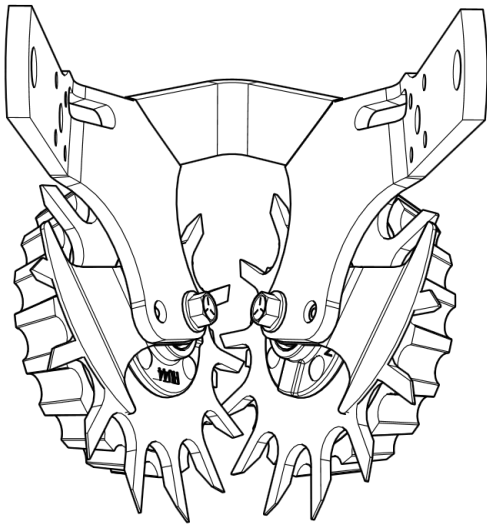

### OPTION B: OFFSET

(Left wheel in front hole and right wheel in rear hole)

The staggered configuration allows the wheels to turn more easily in loose soil.

With this configuration, we suggest running the left wheels in the rear hole on the half of the planter and the right wheels in the rear hole on the other half of the planter (when viewed from behind).

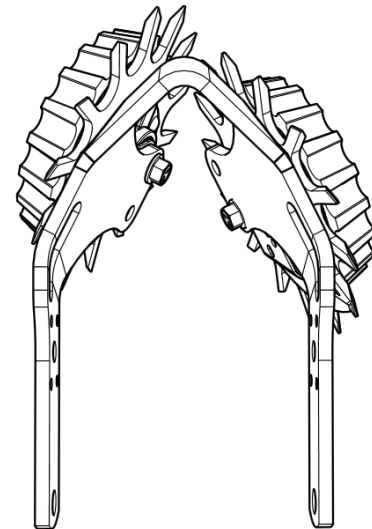
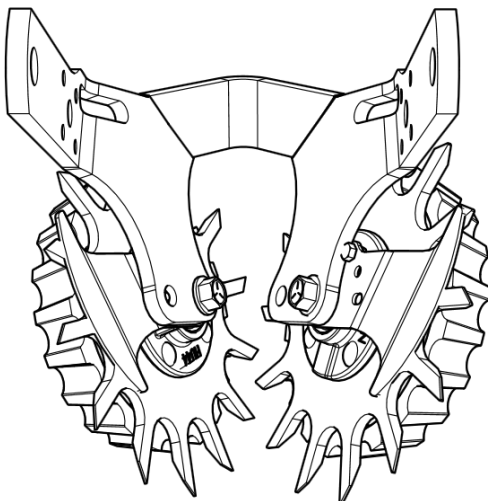



## STEP 5: INSTALL SMART CLEAN CYLINDER BOTTOM ANCHOR

**IMPORTANT: Skip to [Step 6](#) if optional SmartClean System was not purchased**

**Skip to next page if installing SmartClean on planter w/ unit mounted no-till coulters**

If the optional SmartClean cylinder was purchased, install the SmartClean cylinder bottom anchor, before installing the wheels, as shown below. Proper location of the bottom anchor mounting bolts is determined by the wheel configuration you've chosen from page 5. The anchor is installed on the right side of the frame.

### Intersected Configuration

1. Place 5/8" x 1 3/4" flange patch bolt through front hole of frame.
2. Place 5/16" x 1 1/4" BOLT, 5/16" FLAT WASHER, 5/8" BUSHING & 5/16" NUT through D-Lock Deflector/Scraper (see pg. 8) and rear hole of frame. Torque to 13 ft-lbs to prevent anchor from rotating.

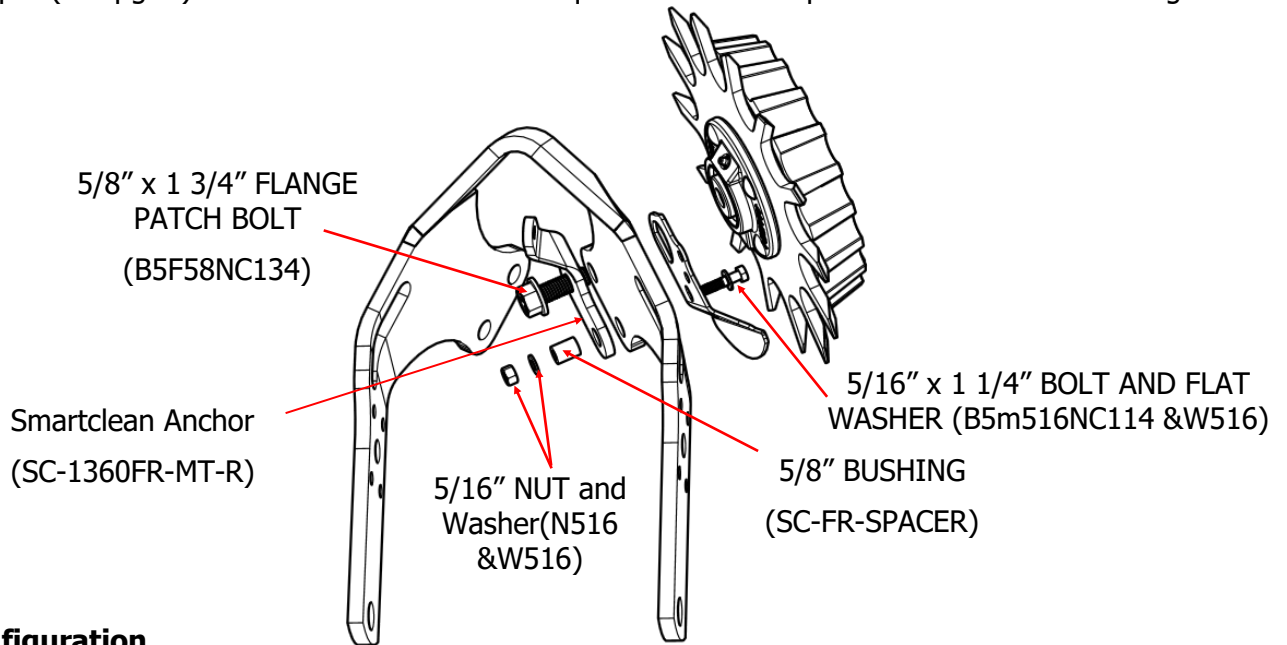

### Offset Configuration

1. Place 5/8" x 1 3/4" flange patch bolt through rear hole of frame.
2. Place 5/16" x 1 1/4" BOLT, 5/16" FLAT WASHER, 5/8" BUSHING, & 5/16" NUT through D-Lock Deflector/Scraper (see pg 8) and front hole of frame. Torque to 13 ft-lbs to prevent anchor from rotating.

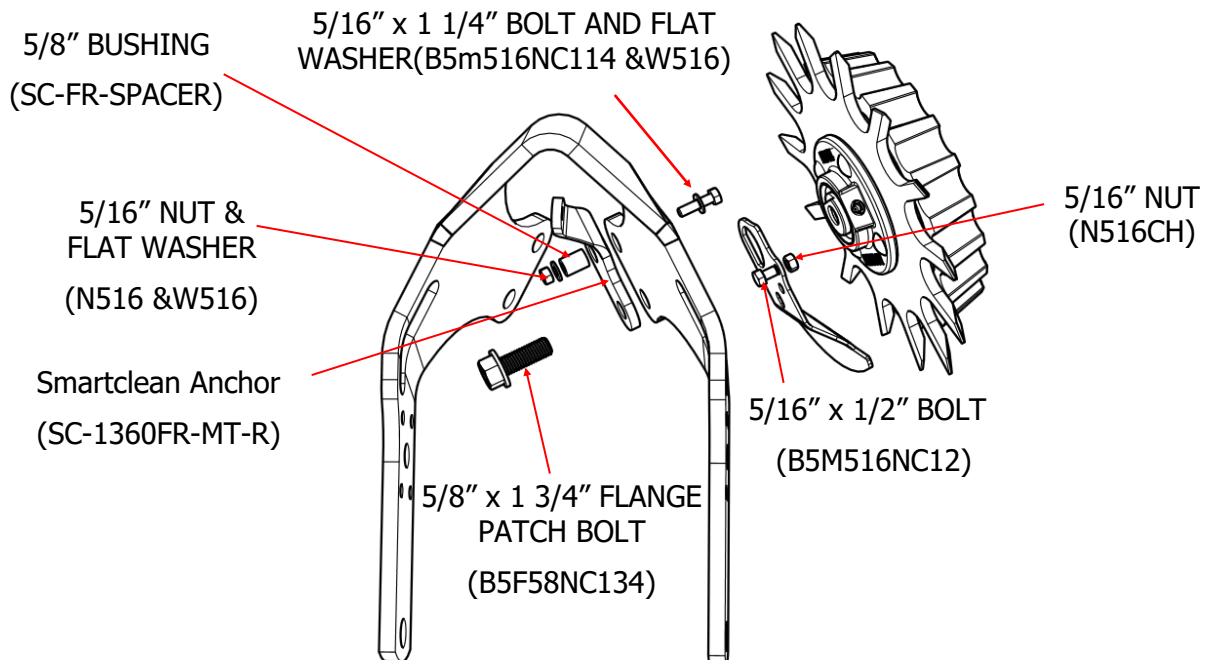

## STEP 5A: FOR PLANTERS WITH A UNIT MOUNTED NO-TILL COULTER ( BDC1360, BKC1360 & BK4C)

Despite the standard SmartClean bottom anchor (SC-1360FR-MT-R) described in the previous page, the SmartClean bottom anchor is installed in the left arm of the frame and it points backward as shown in the picture for planters with a unit mounted no-till coulters. Follow the same instruction as described for (SC-1360FR-MT-R) to install the bottom anchor.

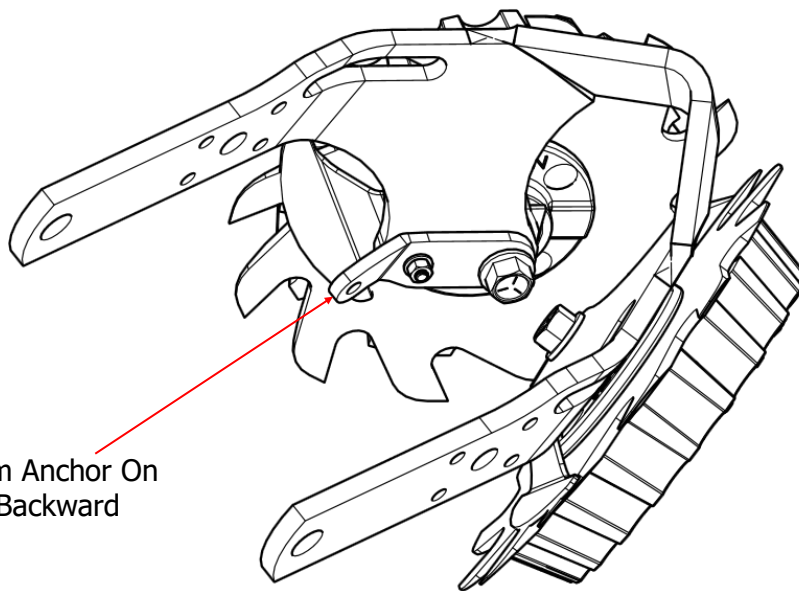

SmartClean Bottom Anchor On  
Left Arm Pointing Backward

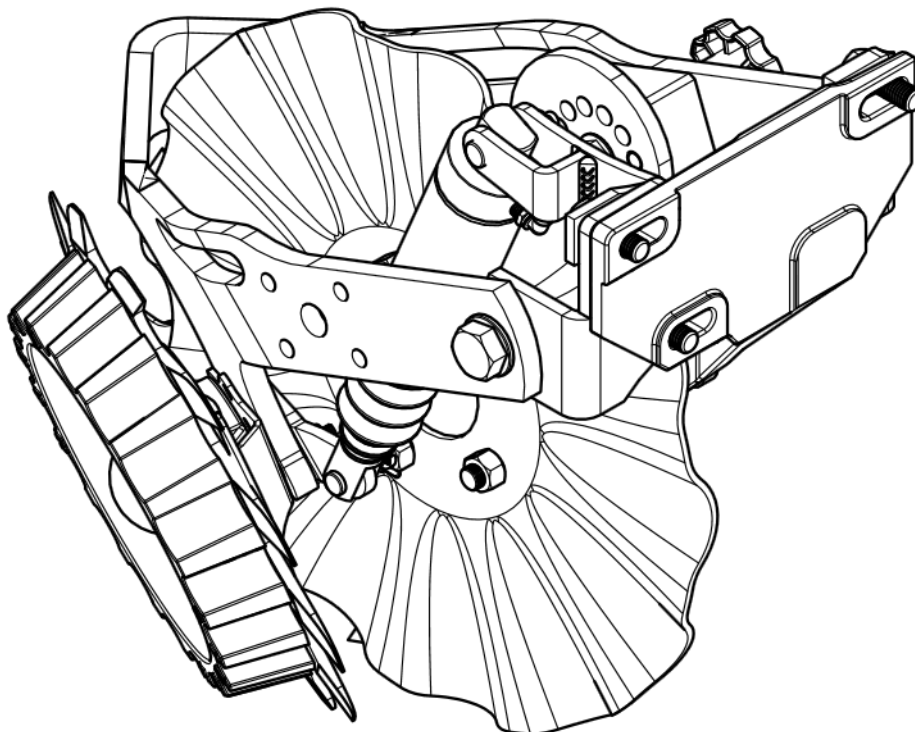



## STEP 6: INSTALL WHEEL ASSEMBLIES

**IMPORTANT:** Skip to [Step 6C](#) if not using optional D-Lock Deflector (Scraper)

**NOTE:** The D-Lock Deflector (Scraper) is recommended (in place of the standard D-Lock) when operating in wetter conditions, or damp stringy residue, to reduce wrapping.

**NOTE:** Either the D-Lock deflector (illustrated below and on next page) or the D-Lock (illustrated on page 11) must be installed to allow the 5/8" bolt to tighten without the hub rotating.

**NOTE:** Proper location of the D-Lock Deflector is determined by wheel configuration chosen on page 6.

### STEP 6A: PROPERLY CONFIGURE THE D-LOCK DEFLECTOR (SCRAPER)

#### Intersected Configuration

(Wheel in front hole)

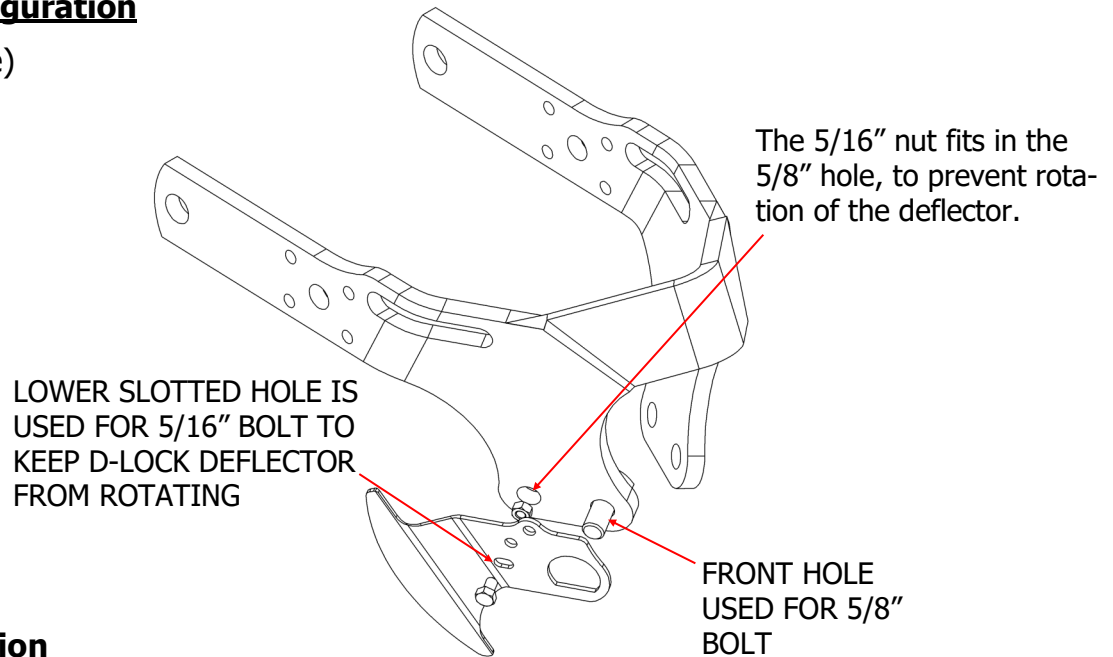

#### Offset Configuration

(Wheel in rear hole)

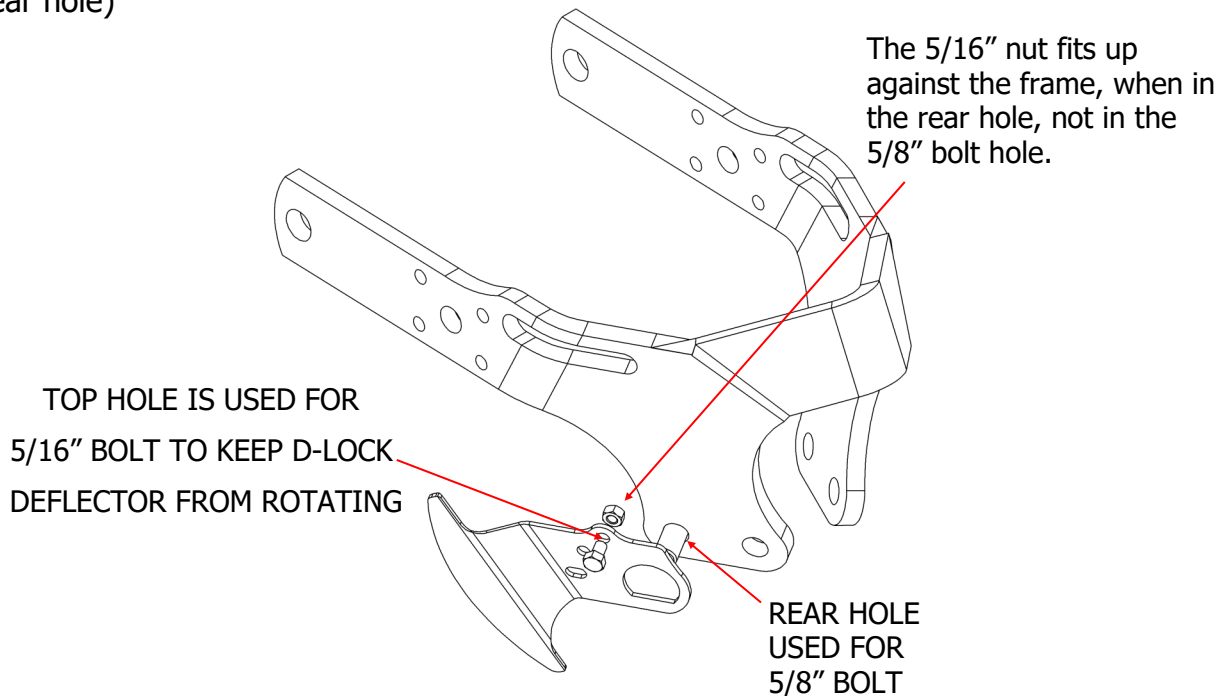

## STEP 6: INSTALL WHEEL ASSEMBLIES (CONT.)

**IMPORTANT:** Skip to [Step 6C](#) if not using optional D-Lock Deflector (Scraper)

### **STEP 6B: INSTALL WHEEL ASSEMBLIES USING OPTIONAL D-LOCK DEFLECTOR (SCRAPER)**

- 1) Attach the D-lock deflector (DLD-02L) to the end of the hub axle, making sure it is flush with the end of the axle, before bolting the axle to the frame. (For placement of 5/16" stop bolt see figure on previous page)
- 2) Secure the hub to the frame with the 5/8" flange patch bolt. Using a torque-wrench, tighten to 112 ft-lbs. Re-tighten after first day's use.
- 3) Install the wheel (part # to the outside) and side treader wheel on the hub, using the four carriage bolts and flange nuts. Torque to 23 ft-lbs. Re-tighten after first day's use.
- 4) The wheel marked TW3813-R4 or RTW1412.5-R4 is for use on the right side of the frame (as viewed from behind the machine). Repeat for opposite side.

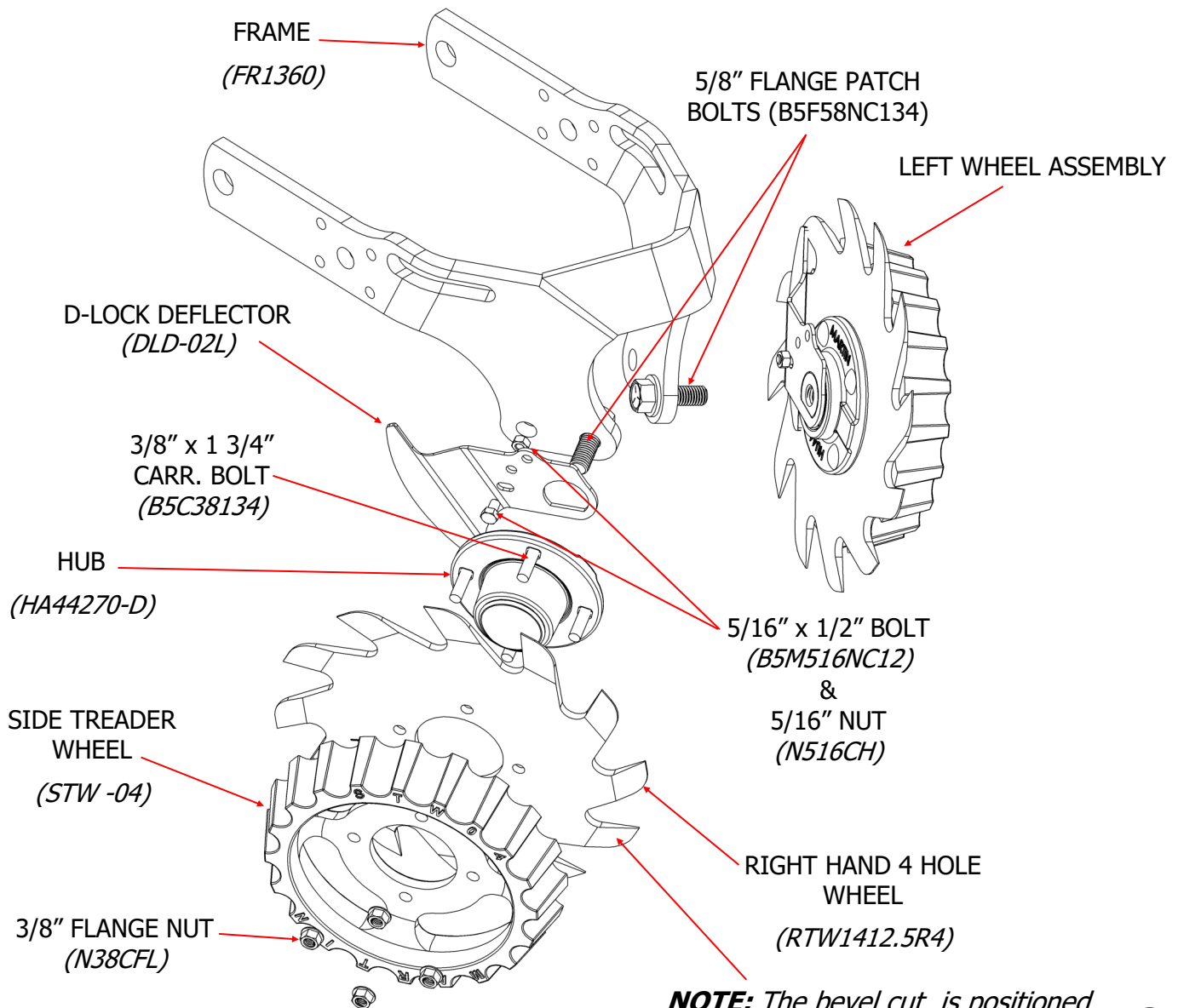

**NOTE:** The bevel cut is positioned "outward".

## STEP 6: INSTALL WHEEL ASSEMBLIES (CONT.)

### STEP 6C: INSTALL WHEEL ASSEMBLIES USING STANDARD D-LOCK

1. Attach the D-lock to the end of the hub axle making sure it is flush with the end of the axle before bolting the axle to the frame.
2. Secure the hub to the frame with the 5/8" bolt. Using a torque-wrench, tighten to 112 ft-lbs. Re-tighten after first day's use.
3. Install the wheel (part # to the outside) and side treader wheel on the hub, using the four carriage bolts and flange nuts. Torque to 23 ft-lbs. Re-tighten after first day's use.
4. The wheel marked TW3813-R4 or RTW1412.5-R4 is for use on the right side of the frame (as viewed from behind the machine). Repeat for opposite side.

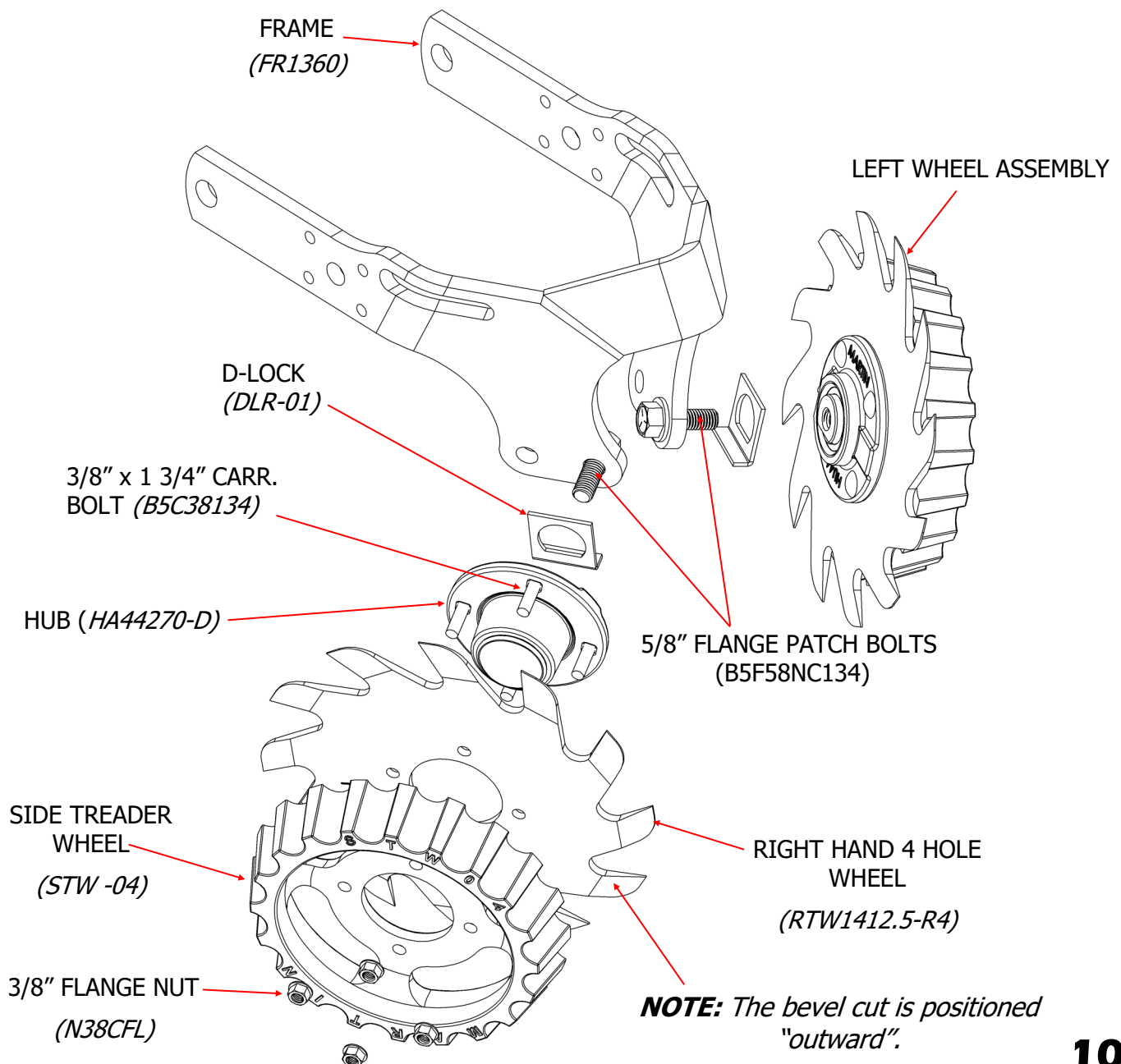

## STEP 7 : INSTALL THE OPTIONAL SMARTCLEAN CYLINDER

Install the SmartClean cylinder between the top and bottom brackets. Use thicker (7/16") pin on the top brackets and thinner (3/8") pin on the bottom bracket as shown in the picture below.

**NOTE:** Cylinder may be installed with elbow valves in either up or down orientation, depending on user preference.

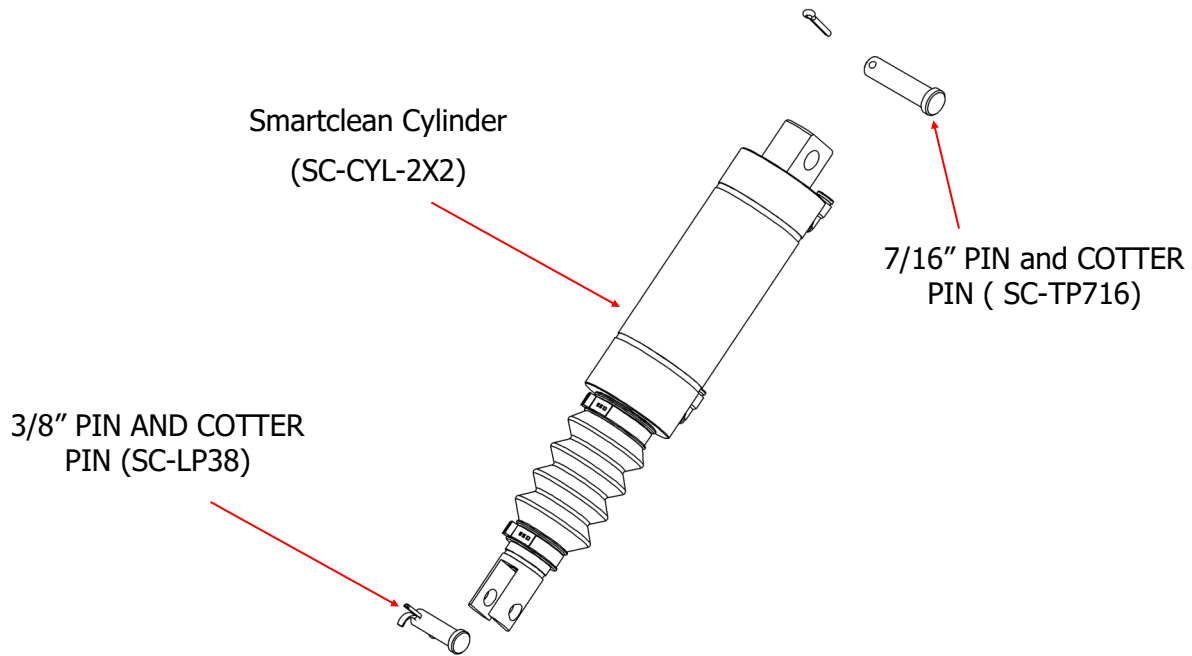

### Note:

**It is very important to limit the row cleaner down travel to prevent the air cylinder from extending fully. This is accomplished by setting the threaded stop bolt adjustment or optional cam adjustment to catch the row cleaner just before the cylinder reaches the end of its stroke. Failure to do so can result in premature cylinder failure.**

## PARTS LIST FOR 1360 HUB ASSEMBLY (HA44270-D)

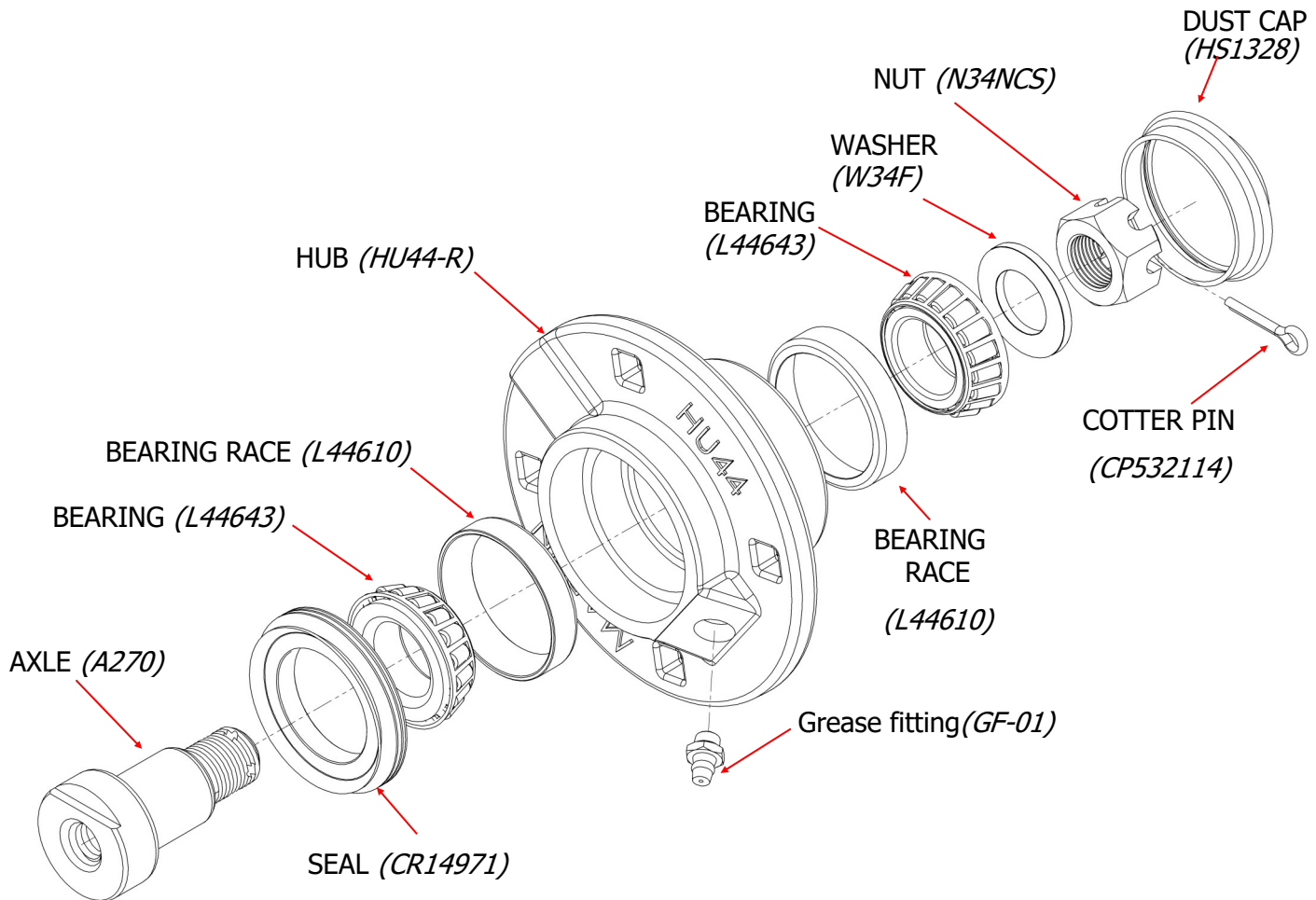

### Row Cleaner Hub Preventative Maintenance

The Row Cleaner hub is designed to be “flushed out” with lubrication, without damaging the triple lip seal. To “flush” the hub, lubricate until fresh grease is visible around the seal.

- In most conditions annual lubrication of the Row Cleaner hub is sufficient
- More frequent lubrication is recommended in dusty or sandy conditions

**NOTE:** Hubs may feel tight when first installed. They will loosen after they “run in”.

### Row Cleaner Hub Bearing Preload Adjustment

Maintaining proper bearing preload is crucial to bearing life. Monitor and adjust annually. To adjust:

- Remove the dust cap
- Remove the cotter pin
- Tighten the 3/4” nut until you feel zero end play
- Gently back the nut off, leaving .01” - .012” end play
- Replace the cotter pin and dust cap

**NOTE:** End play is checked by pulling out on the top of the wheel while pushing in on the bottom.

**EXPLODED VIEW FOR WA1360**

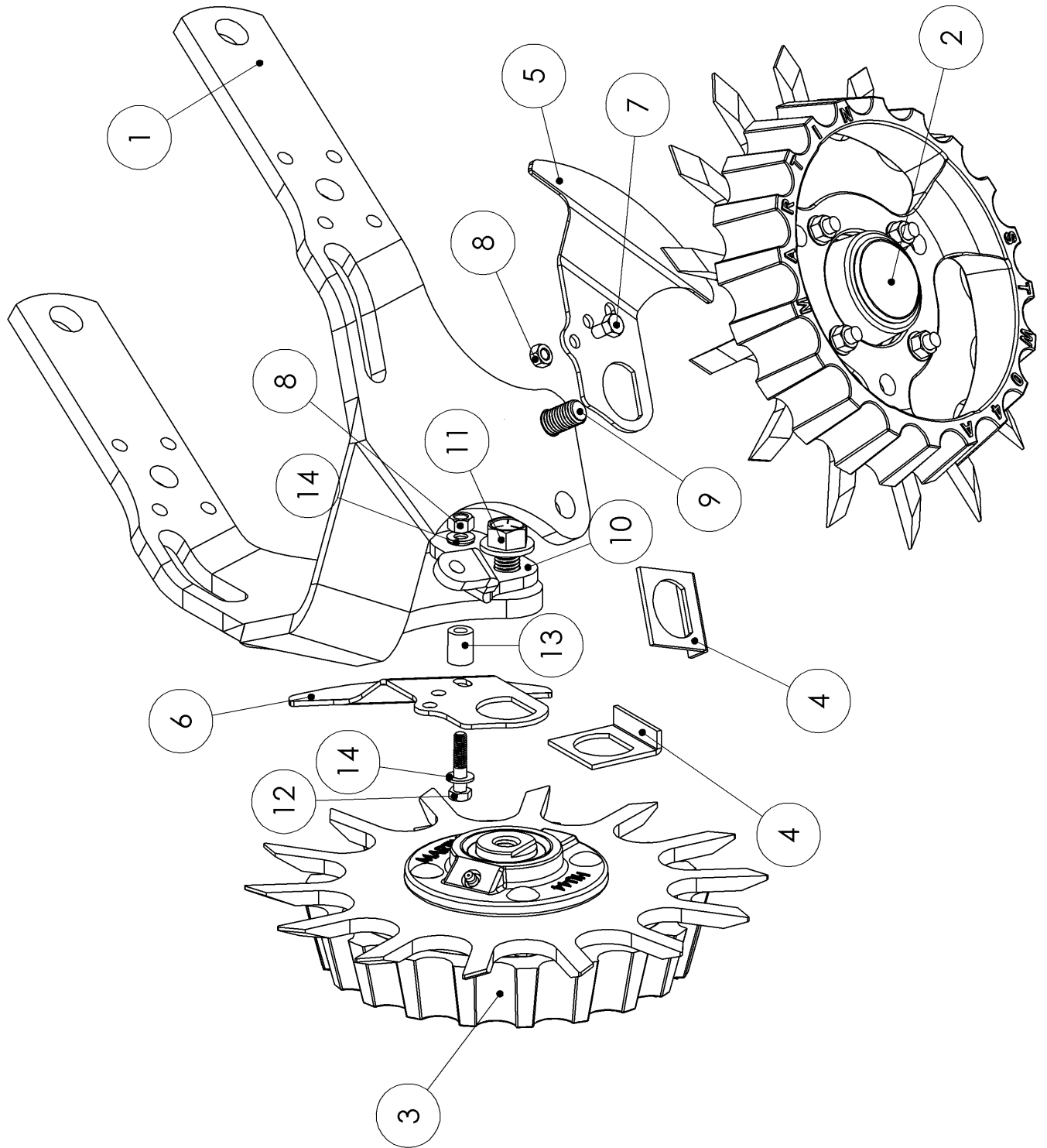



**PARTS LIST FOR WA1360**

ITEM NO.	PART NUMBER	DESCRIPTION	QTY.
1	1360FR	Frame	1
2	ATW13L27044STW	Left Toothed Wheel Assembly	1
3	ATW13R27044STW	Right Toothed Wheel Assembly	1
4	DLR-01	D-Lock ( Not used with Scrapers)	2
5	DLD-02L	Left Scraper ( Substitute For D- Lock)	1
6	DLD-02R	Right Scraper( Substitute For D- Lock)	1
7	B5M516NC12	5/16" X1/2" Bolt	2
8	N516CH	5/16" Nut	3
9	B8F58NC112	5/8" X 1 1/2" Flange Patch Bolt	1
10	SC-1360FR-MT-R	Smartclean Anchor	1
11	B8F58NC134	5/8" X 1 3/4" Flange Patch Bolt	1
12	B5M516NC114	5/16" x 1 1/4" Bolt	1
13	SC-FR-Spacer	5/8" Bushing	1
14	W516	5/16" Washer	2



**The most trusted name in no-till  
Established 1991**

**Martin Industries LLC**  
206 Elk Fork Road  
Elkton, KY 42220  
Telephone: 270-265-5817  
E-Mail: [martin@martintill.com](mailto:martin@martintill.com)  
[www.martintill.com](http://www.martintill.com)