



**ALL STEER**  
MODEL 2000  
**HIGH CAPACITY CART**  
**OPERATOR'S MANUAL**  
PART IDENTIFICATION

2565-726\_REV\_D 12/11



**YETTER MANUFACTURING CO.**  
*FOUNDED 1930*

Colchester, IL 62326-0358  
Toll free: 800/447-5777  
309/776-3222 (Fax)  
Website: [www.yetterco.com](http://www.yetterco.com)  
E-mail: [info@yetterco.com](mailto:info@yetterco.com)

**YETTER**

## FOREWORD

You've just joined an exclusive but rapidly growing club.

For our part, we want to welcome you to the group and thank you for buying a Yetter product.

We hope your new Yetter products will help you achieve both goals-increase your productivity and increase your efficiency so that you may generate more profit.

This operator's manual has been designed into four major sections: Foreword, Safety Precautions, Installation Instructions and Parts Breakdown.



This **SAFETY ALERT SYMBOL** indicates important safety messages in the manual. When you see this symbol, be alert to the possibility of **PERSONAL INJURY** and carefully read the message that follows.

The word **NOTE** is used to convey information that is out of context with the manual text. It contains special information such as specifications, techniques and reference information of a supplementary nature.

The word **IMPORTANT** is used in the text when immediate damage will occur to the machine due

to improper technique or operation. Important will apply to the same information as specified by note only of an immediate and urgent nature.

It is the responsibility of the user to read the operator's manual and comply with the safe and correct operating procedure and to lubricate and maintain the product according to the maintenance schedule in the operator's manual.

The user is responsible for inspecting his machine and for having parts repaired or replaced when continued use of the product would cause damage or excessive wear to the other parts.

It is the user's responsibility to deliver his machine to the Yetter dealer who sold him the product for service or replacement of defective parts, which are covered by the warranty policy.

If you are unable to understand or follow the instructions provided in this publication, consult your local Yetter dealer or contact:

### **YETTER MANUFACTURING CO.**

309/776-4111

800/447-5777

309/776-3222 (FAX)

Website: [www.yetterco.com](http://www.yetterco.com)

E-mail: [info@yetterco.com](mailto:info@yetterco.com)

## WARRANTY

Yetter Manufacturing warrants all products manufactured and sold by it against defects in material. This warranty being expressly limited to replacement at the factory of such parts or products as shall appear to be defective after inspection. This warranty does not obligate the Company to bear cost of labor in replacement of parts. It is the policy of the Company to make improvements without incurring obligations to add them to any unit already sold. No warranty is made or authorized to be made, other than herein set forth. This warranty is in effect for one year after purchase.

Dealer \_\_\_\_\_

**Yetter Manufacturing warrants its own products only and cannot be responsible for damages to equipment on which mounted.**

# SAFETY PRECAUTIONS

You can make your farm a safer place to live and work if you observe the safety precautions given. Study these precautions carefully and insist those working with you and for you follow the precautions.

Finally, remember this an accident is usually caused by someone's carelessness, neglect or oversight.

**A brief description of signal words that may be used in this manual:**

**CAUTION:** Used as a general reminder of good safety practices or to direct attention to unsafe practices.

**WARNING:** Denotes a specific potential hazard.

**DANGER:** Denotes the most serious specific potential hazard.



## CAUTION

Consult your implement and tractor operator's manual for correct and safe operating practices. Be aware of towed implement width and allow safe clearance.



## CAUTION: SAFETY SIGNS

Safety decals are placed on the implement to alert the operator and others to the risk of personal injury or unsafe operation during normal operations and servicing.

1. The safety decals must be kept clean and in good condition to ensure that they are legible.
2. Safety decals must be replaced if they are missing or illegible.
3. When components are replaced during repair or servicing, check that the new components include the necessary safety signs.
4. Replacement safety decals may be obtained from your local dealer.



## WARNING

Read these instructions carefully to acquaint yourself with the Equipment. Working with unfamiliar equipment can lead to accidents.

Never park the equipment on a steep incline or leave the equipment running unattended.

Never clean, lubricate or adjust a machine that is in motion.

Always check that straps are secure.

Make sure latches are in pinned position when moving equipment.

Do not allow children to operate this equipment.

Do not allow riders on the equipment, trailer and/or pick-up.

Use speed and caution dictated by the terrain being traversed. Do not operate on any slope steep enough to cause tipping or loss of control.

Read and understand the operator's manual and require all other persons who will operate the equipment to do the same.

If operating on public roadways, where legal, be certain all lighting is operating properly and observe all traffic laws.

Beware of increased stopping distances and control effort when operating with implements attached.

Be familiar with all controls and be prepared to stop equipment quickly in an emergency.

**FAILURE TO HEED MAY RESULT IN PERSONAL INJURY OR DEATH.**

## TABLE OF CONTENTS

	PAGE
FORWARD/WARRANTY.....	2
SAFETY INFORMATION.....	3
TABLE OF CONTENTS.....	4
GENERAL INFORMATION/BOLT TORQUE.....	5
ASSEMBLY INSTRUCTIONS.....	6-12
OPERATING/MAINTENANCE INSTRUCTIONS.....	13-15
PARTS IDENTIFICATION.....	16-53

# GENERAL INFORMATION

High capacity with high clearance keeps your planter and or side-dress operation running longer, the perfect answer for bigger, faster farming operation. The name of the game is to cover more acres each day and that is exactly what the 2000 Series All Steer High Capacity Cart accomplishes. What makes the All Steer High Capacity Cart unique is its tire-tracking feature where the rear tires track the front tires at all times resulting in less compaction or less downed crops. All Steer carts are a multi-use high capacity tool for many applications such as starter fertilizer, pre-plant fertilizer, side-dressing herbicides and insecticides. Tank capacities of up to 1600 gallons stretch out the time between refills helping to eliminate non-productive down time.

Incorporating a 2000 Series All Steer High Capacity Cart into your farming operation sets the stage to capitalize on maximum yield potential. Field tests have shown the sooner the seed is planted in the optimum planting window the greater the opportunity is to maximize yield potential. In addition, research has proven yield gain can also be made with timely side dressing application of fertilizer.



Reliability and durability are built into each All Steer for years of dependable service. 2" x 8" structured steel tubing is the foundation for the tank saddle providing for an extra strong mounting platform that evenly distributes stress loads on the tank. When it comes to carrying the load, strength is at the center of the design parameters for the All Steer High Capacity Cart. Heavy-duty 8 bolt hubs, 2 3/4" spindles, durable tires and rims are the backbone of the axle assembly. Each axle is connected to the tank saddle by a greaseable 5<sup>th</sup> wheel mechanism, which allows for steering of both axle assemblies. In addition for a smoother ride the front axle has a unique feature of being able to pivot horizontally. Wide stance mounting lugs are welded to the front axle for mounting the telescoping pull hitch for a consistent equal pull. The telescoping hitch features speed hook-ups, which gets you up and going faster. Ground clearance is abundant, especially for side dressing. Up to a generous 27" is available depending on the tire selection.

## BOLT TORQUE

### READ THESE INSTRUCTIONS FIRST:

1. Improperly tightened bolts will result in damage, breakage, expense, and down time.
2. Always replace bolts with the specified grade and type.
3. Torque properly before first use of the machine and every 2-4 hours of use until you are sure bolts are staying tight.
4. The chart below is a guide for proper torque. Use it unless a specified torque is called out elsewhere in the manual.
5. Torque is the force you apply to the wrench handle or the cheater bar, times the length of the handle or bar.
6. Use a torque wrench whenever possible.

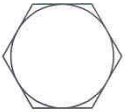
The following table shows torque in ft. lbs.

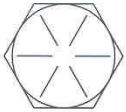
BOLT DIA. AND THREADS PER INCH	 GRADE 2	 OR  GRADE 5 A-325	 GRADE 8
3/8-16	25	35	50
7/16-14	35	55	80
1/2-13	55	85	125
9/16-12	75	125	175
5/8-11	105	170	235
3/4-10	175	305	425
7/8-9	185	445	690
1-8	260	670	1030
1 1/8-7	365	900	1460
1 1/4-7	515	1275	2060
1 3/8-6	675	1675	2700
1 1/2-6	900	2150	3500
1 3/4-5	1410	3500	5600

Lubricate all bearings and moving parts as assembled and make certain that they work freely.

# ASSEMBLY INSTRUCTIONS

**Step 1.** Attach the axle stubs to the front and rear main axles using the  $\frac{3}{4}$ " X  $2\frac{1}{2}$ " hex head bolts and locknuts.

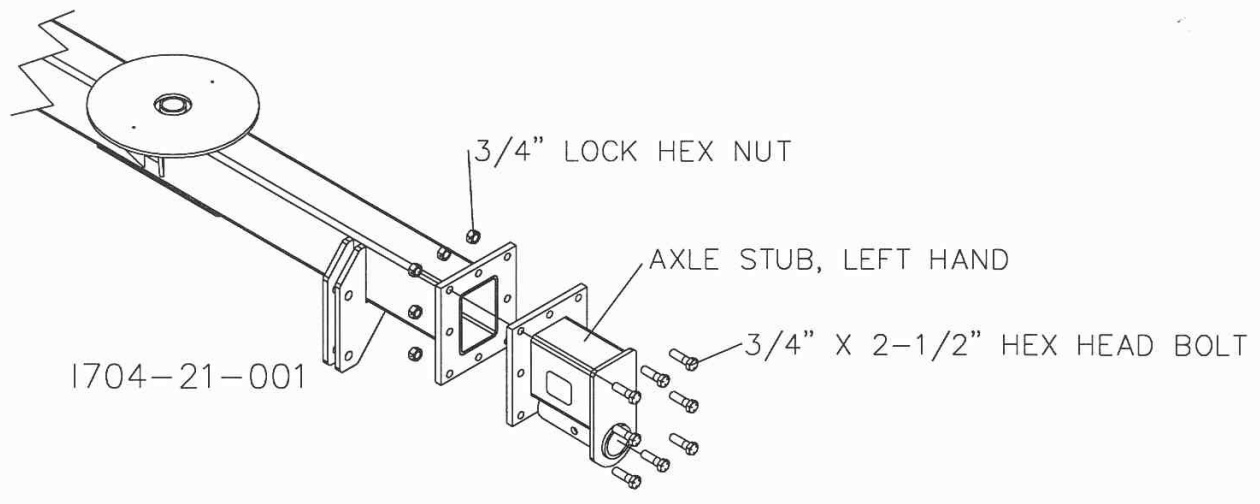

**Step 2.** Attach the hub/spindle assemblies to the axle stub, using the  $\frac{3}{4}$ " X  $4\frac{1}{2}$ " hex head bolts and locknuts.

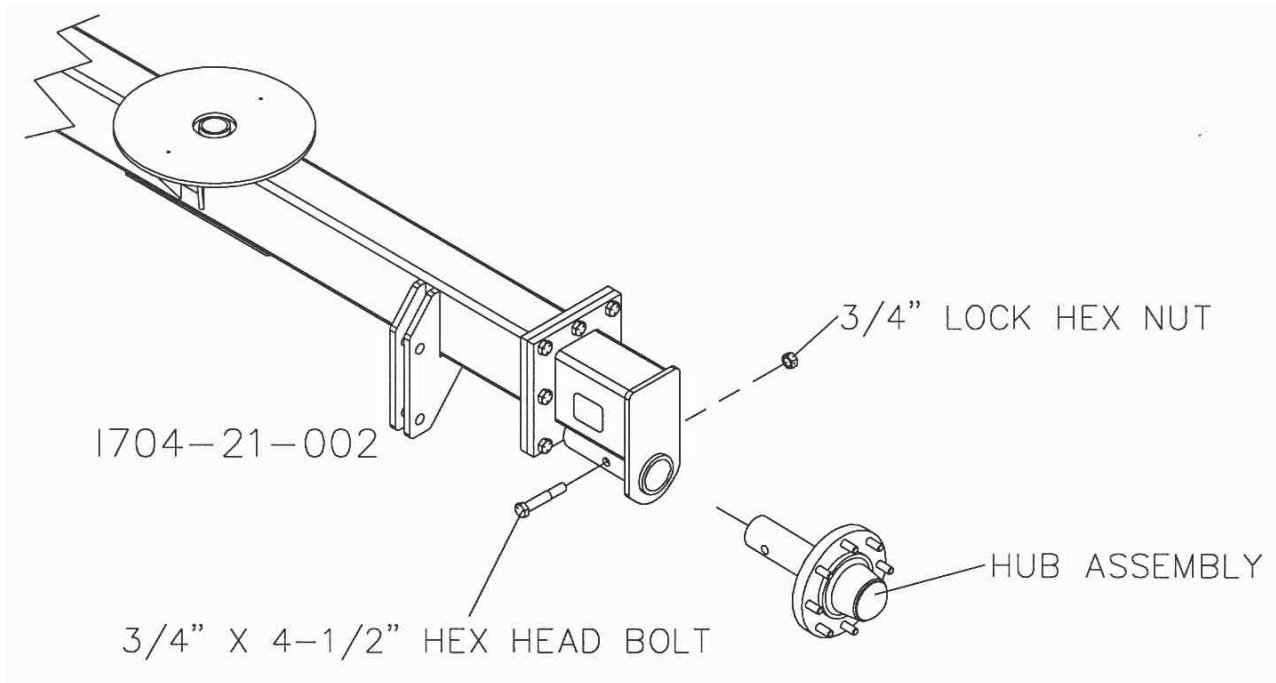

# ASSEMBLY INSTRUCTIONS

**Step 3.** Attach the tire/wheel assemblies to the 8-bolt hubs using the wheel nuts 2520-370. Torque to 100 ft/lbs.



# ASSEMBLY INSTRUCTIONS

**Step 4.** Insert the 2000-200 hitch drawbar tongue into the 2000-201 hitch receiver and install the 1/2" x 4-1/2" bolt and lock nut. Also at this time install the hitch pin and hair pin clip, pin the tongue in the retracted position. Install the 2570-178 jack onto the 2000-201 hitch receiver and secure with a pin and hair pin clip.

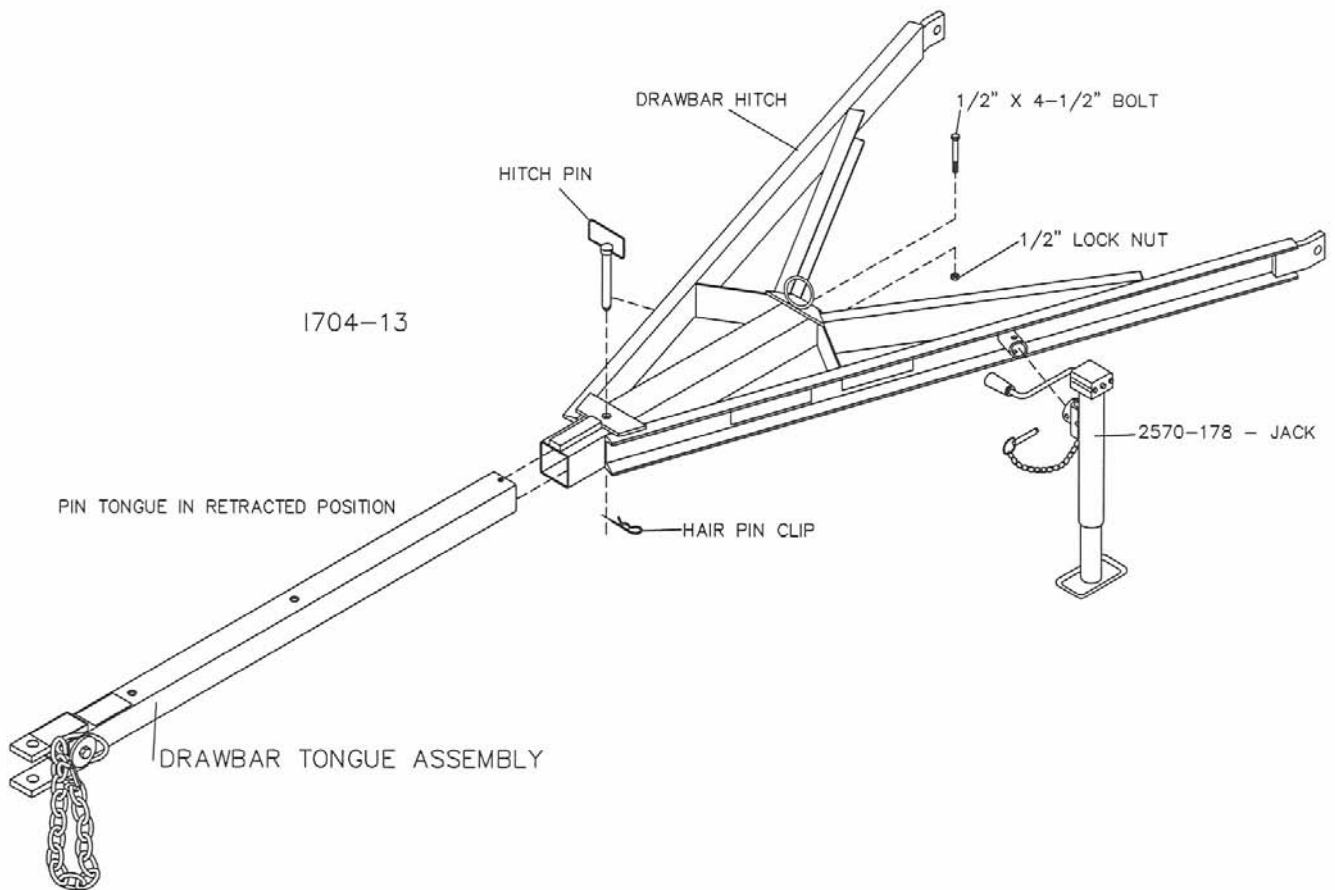



# ASSEMBLY INSTRUCTIONS

**Step 5.** Attach the drawbar assembly to the front axle using 2) 7/8" x 4" bolts and lock nuts.

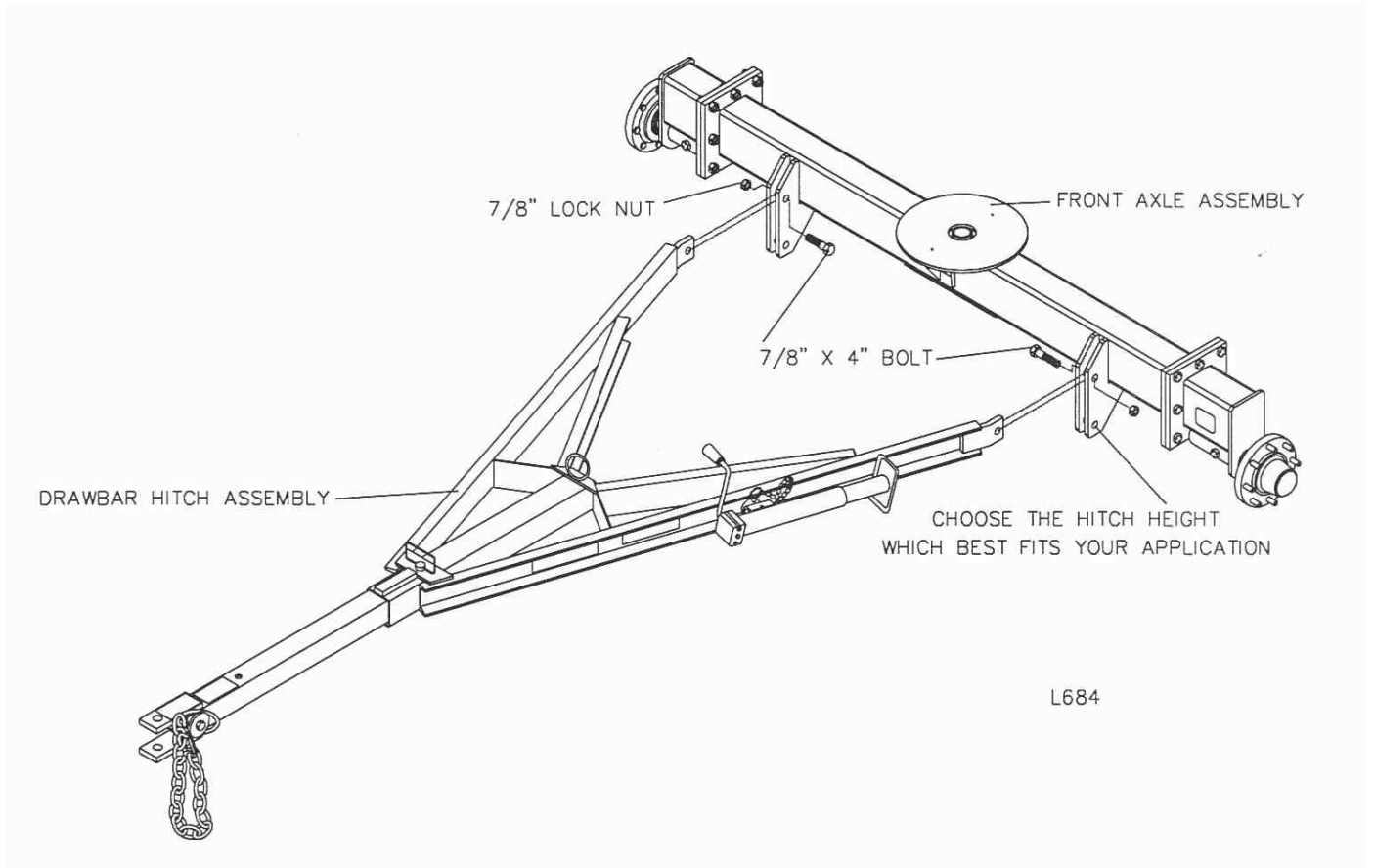

# ASSEMBLY INSTRUCTIONS

**Step 6A.** Install light brackets to rear axle using  $\frac{3}{4}$ " x 7 x 7 u-bolt, and hex nut. Also, attach the red reflectors at the top of each light bracket as shown below.

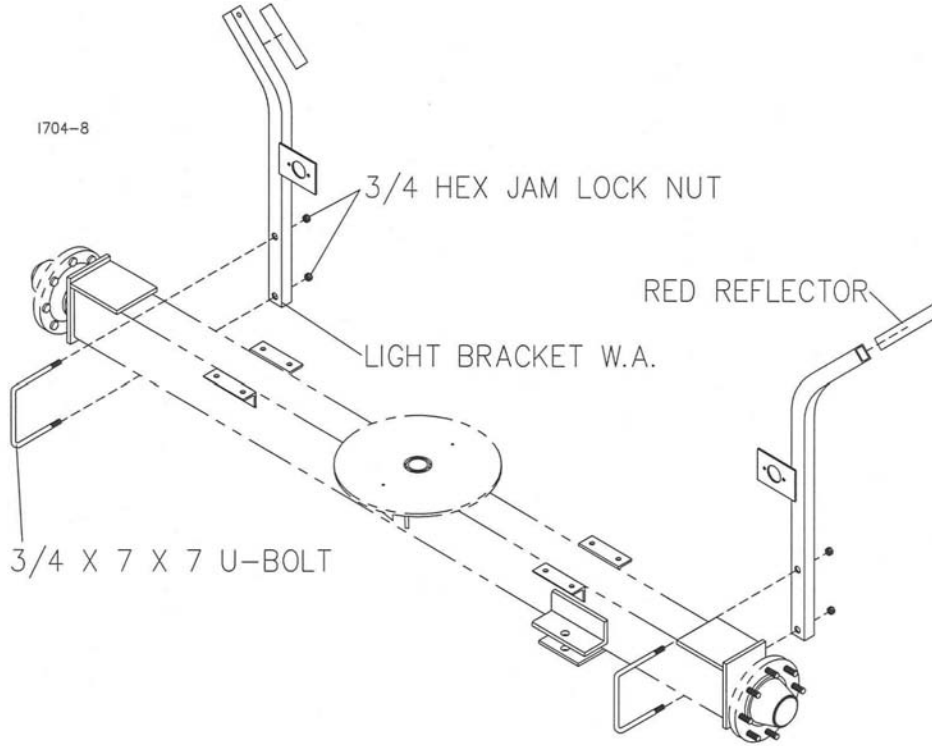

**Step 6B.**

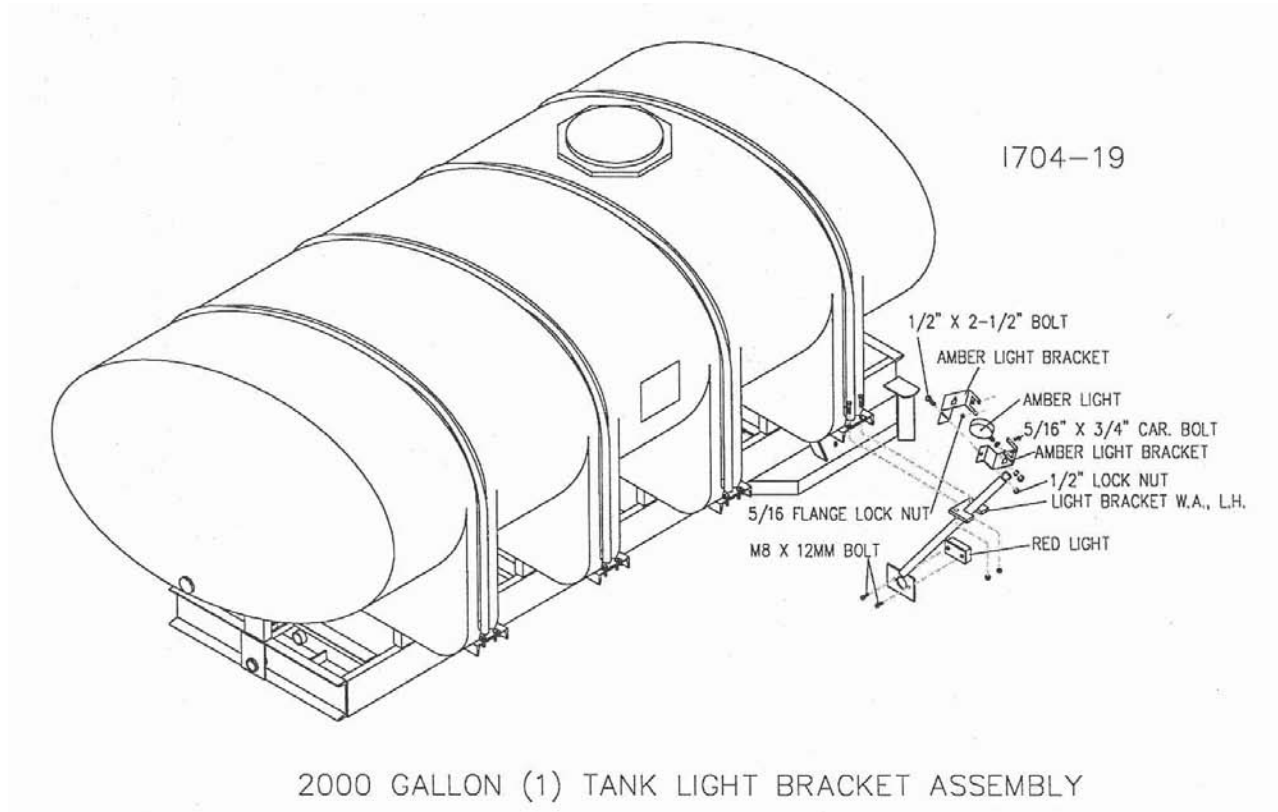

2000 GALLON (1) TANK LIGHT BRACKET ASSEMBLY

# ASSEMBLY INSTRUCTIONS

## Step 6C.

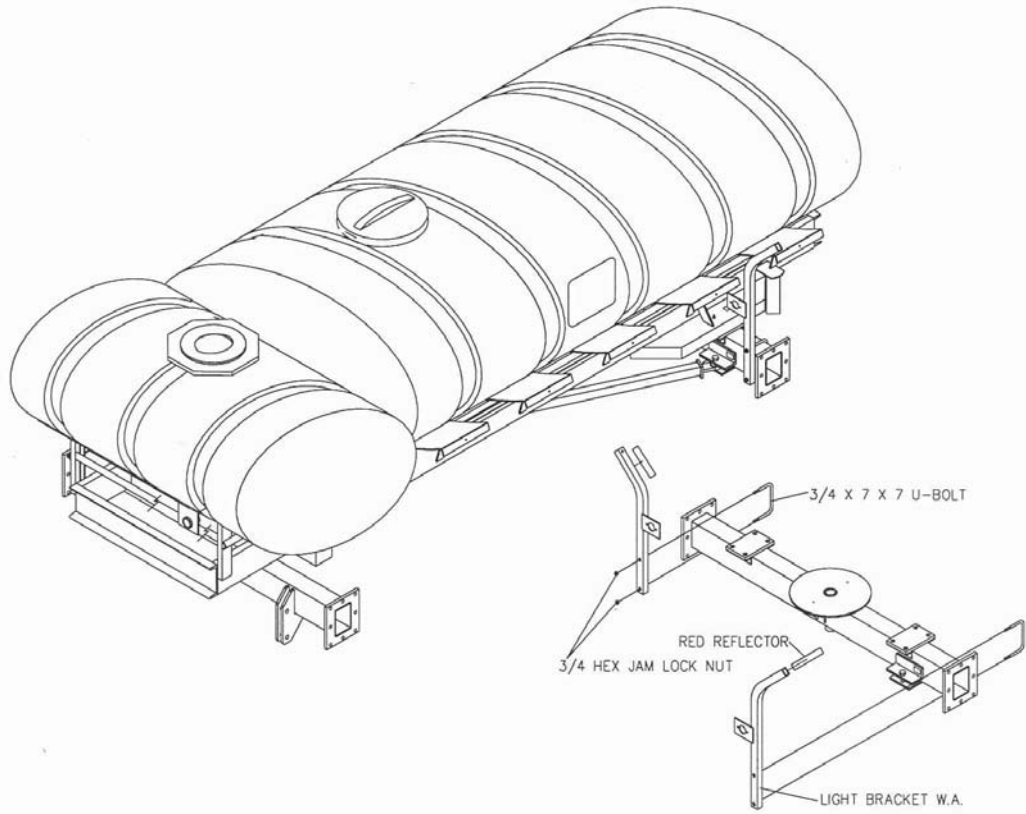

1704-22

## Step 7. Install lights to light brackets using hardware listed above.

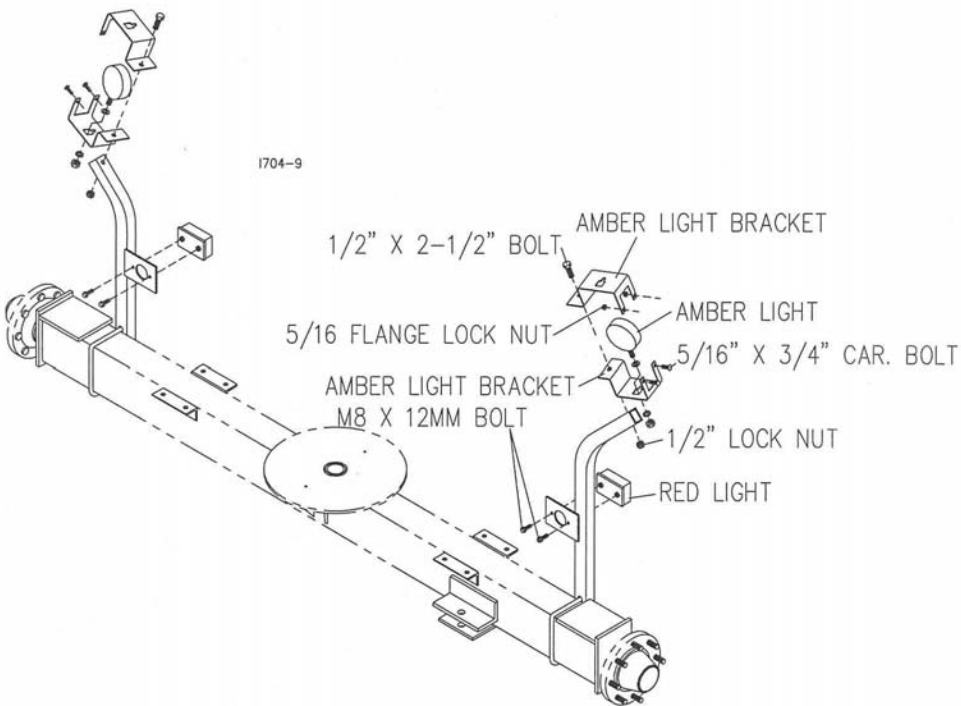

# ASSEMBLY INSTRUCTIONS

## Step 8. Install safety light wiring harness.

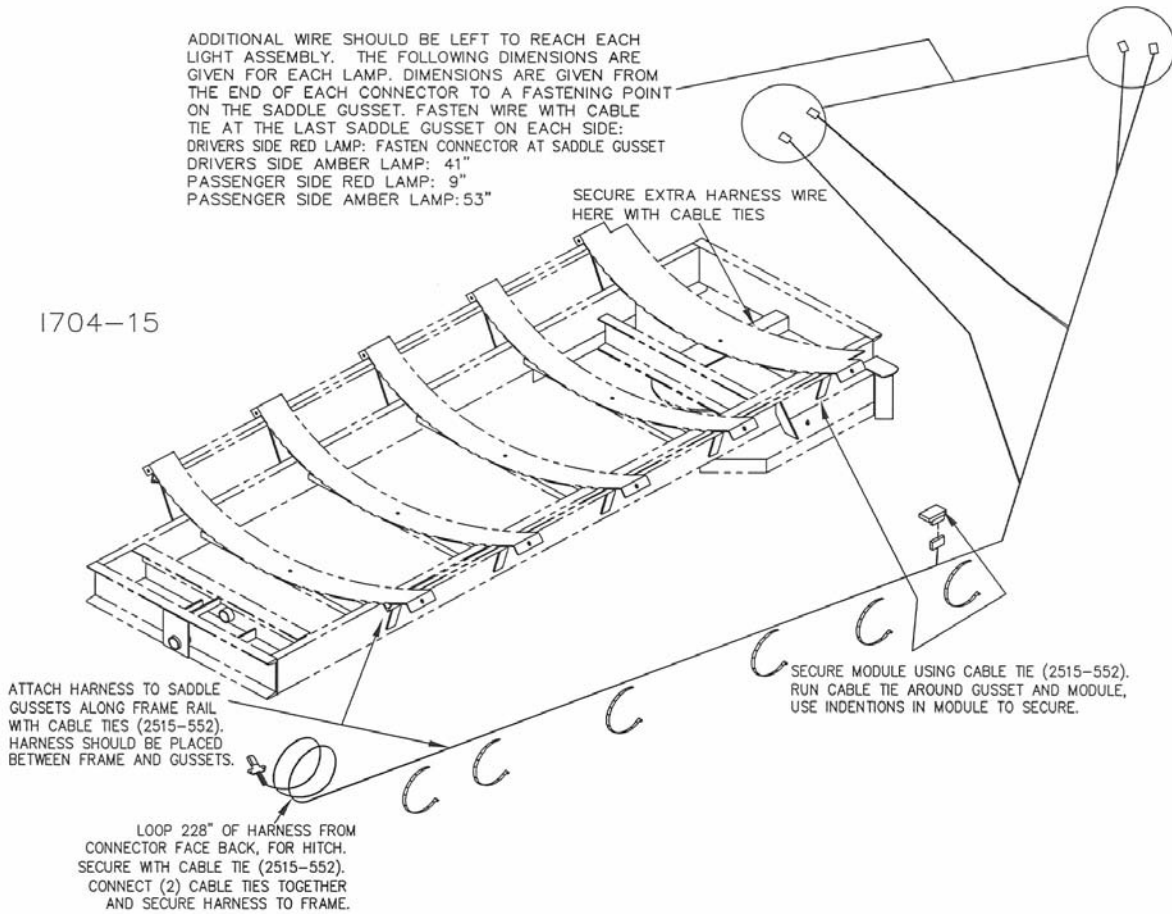

## Plumbing

- No plumbing is supplied by Yetter Manufacturing Inc. Co.
- **SUGGESTION:** Install a vent and overflow hose; plumbed to below the frame, in the event that the tank is overfilled, the product will not come in contact with the metal parts of the ALL STEER cart.

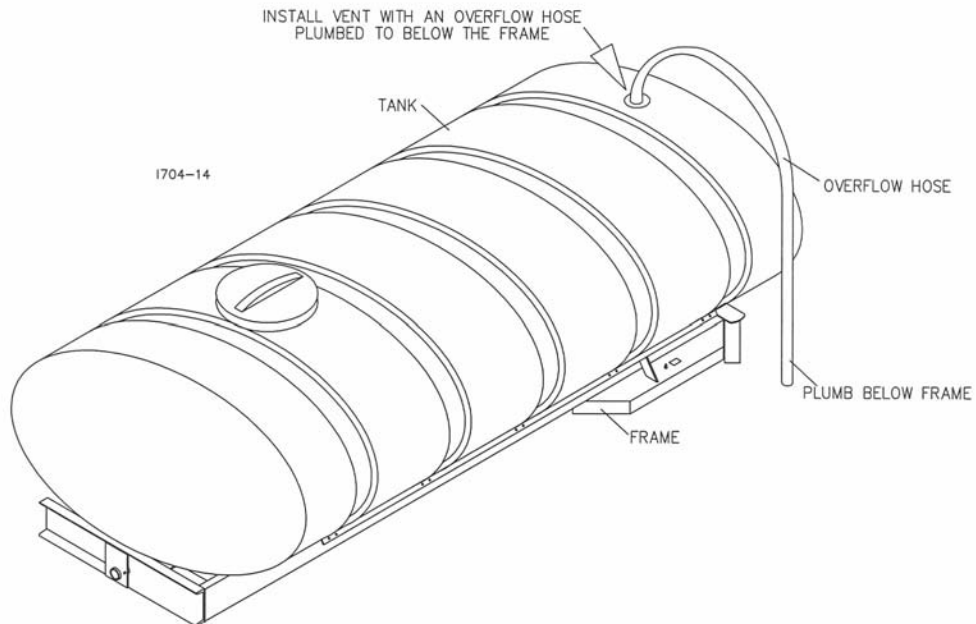

## OPERATION

**DO NOT TOW THE ALL STEER OVER 25 MPH!**



**THE TOW VEHICLE NEEDS TO BE ABLE TO SAFELY HANDLE A MINIMUM OF 24,000 LBS.**



**Maximum carrying capacity of the ALL STEER model 2000 1600-gallon cart is 19,000 lbs.**

- ▲ CAUTION – Check for the 2565-495 SMV decal on the poly tank; if missing or illegible it must be replaced. Also, the safety decals need to be kept clean, visible, and legible.
- ▲ CAUTION - Tighten nylon tie straps and replace if frayed.
- ▲ CAUTION - Use safety chains and safety lights.
- ▲ CAUTION - Check wheel nuts after ½ hour or 25 miles. Check daily.
- ▲ CAUTION – MAX. 25 MPH towing speed.
- ▲ CAUTION – Do not tow in all-steer mode on public roads.
- ▲ CAUTION – Unloading of the All Steer cart is to occur before off-field transport.
- ▲ CAUTION – Use all-steer mode for field use only.

# OPERATION



**FIELD LOCATION**



**TRANSPORT LOCATION**

BE CERTAIN THE PINS ARE ENGAGED IN THE HOLES OF THE INNER STEERING LINK, AFTER CONVERTING FROM ALL STEER (4 WHEEL) TO TRANSPORT (2 WHEEL) STEERING OR WHEN CONVERTING FROM TRANSPORT (2 WHEEL) TO ALL STEER (4 WHEEL) STEERING.

**NOTE: SEVERE DAMAGE TO THE ALL STEER FERTILIZER CART OR ROLL-OVER CAN OCCUR.**

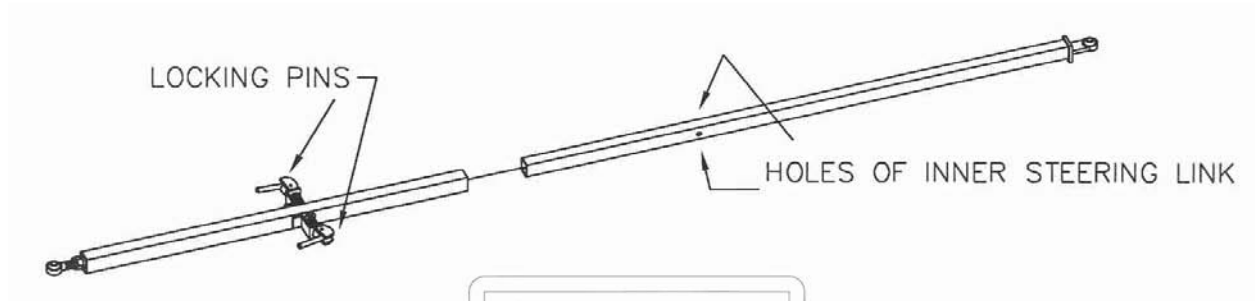

## LUBRICATION

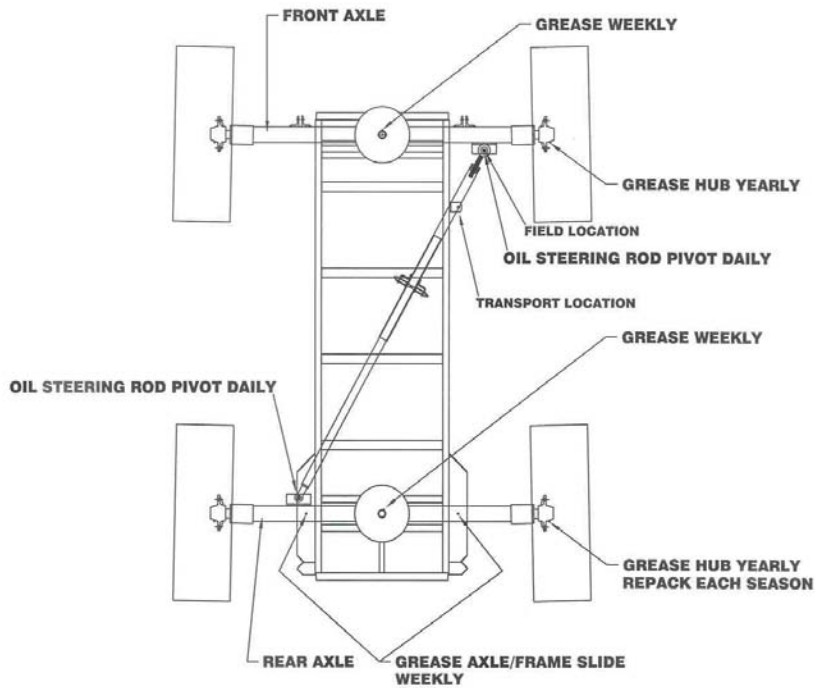

## MAINTENANCE

Check hub for bearing play yearly.

Oil ball sockets to prevent corrosion, seizure and wear.

Replace all worn bolts.

Tire pressure 18.4 x 26-10 ply – Front 30 p.s.i.  
- Rear 30 p.s.i.



**CAUTION** – Explosive separation of a tire and rim parts can cause serious injury or death.

Do not attempt to mount a tire unless you have the proper equipment and experience to perform the job. Have it done by your implement dealer or a qualified repair service.

Always maintain the correct tire pressure. Do not inflate the tires above the recommended pressure.

When inflating tires, use a clip-on chuck and extension hose long enough to allow you to stand to one side and NOT in front of or over the tire assembly. Use a safety cage if available.

Inspect tires and wheels daily. Do not operate with low pressure, cuts, damaged rims or missing lug bolts and nuts.

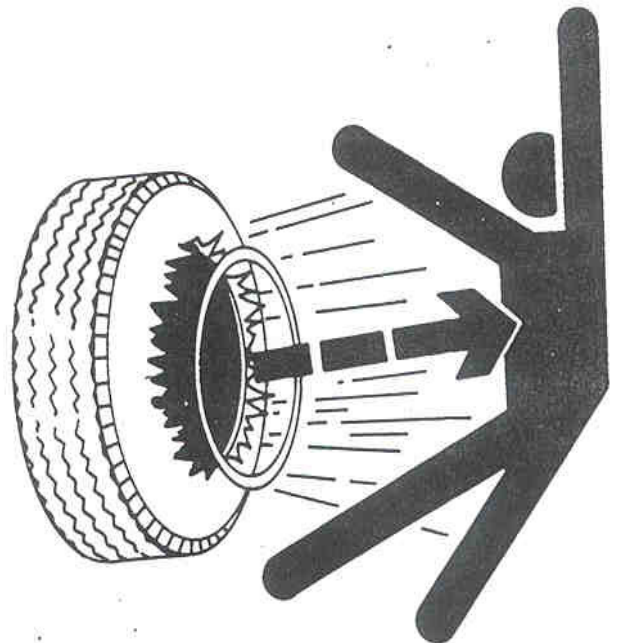

# PARTS IDENTIFICATION

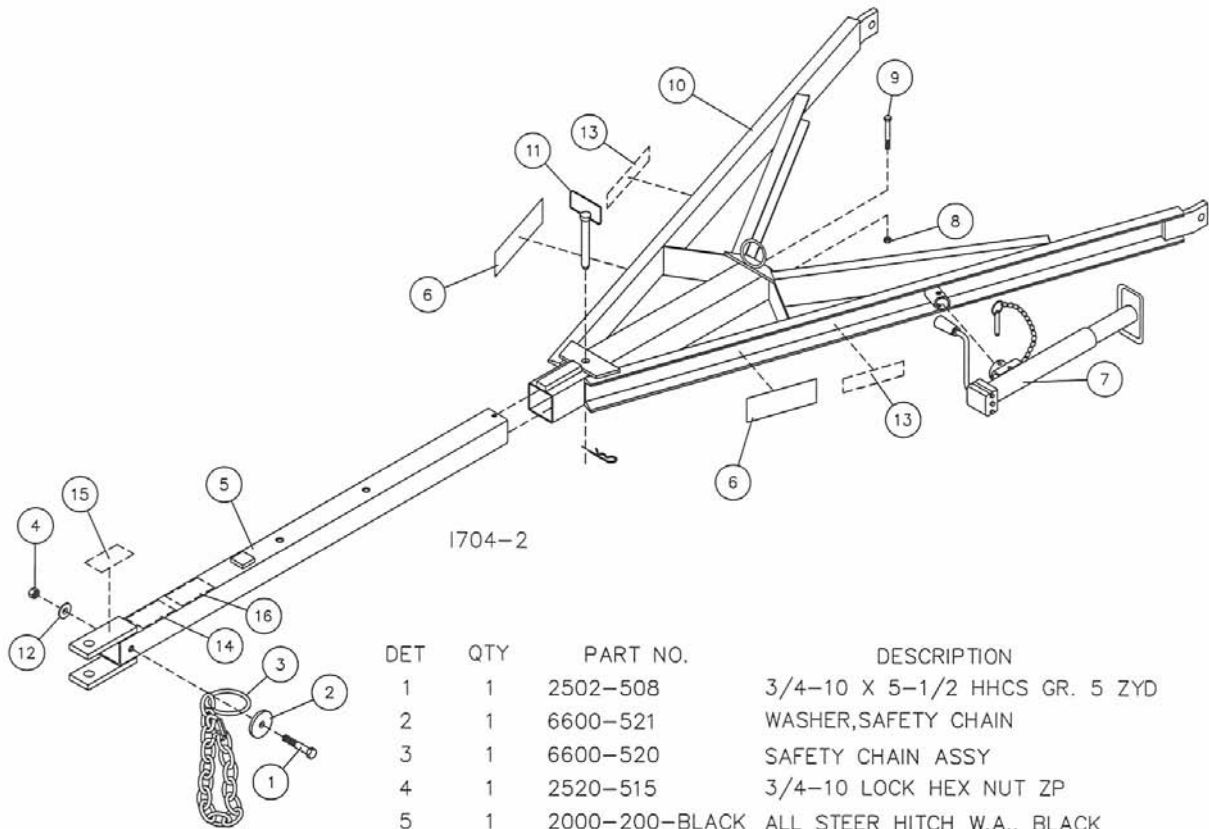

DET	QTY	PART NO.	DESCRIPTION
1	1	2502-508	3/4-10 X 5-1/2 HHCS GR. 5 ZYD
2	1	6600-521	WASHER,SAFETY CHAIN
3	1	6600-520	SAFETY CHAIN ASSY
4	1	2520-515	3/4-10 LOCK HEX NUT ZP
5	1	2000-200-BLACK	ALL STEER HITCH W.A., BLACK
	1	2000-200-BLUE	ALL STEER HITCH W.A., BLUE
	1	2000-200-GREEN	ALL STEER HITCH W.A., GREEN
6	2	2565-058	YET FRM EQUI DE 3-7/16X10-5/16
7	1	2570-178	JACK,H'BLOW #620214-3-SMX-15-0
8	1	2520-357	1/2-13 LOCK HEX NUT ZP
9	1	2502-363	1/2-13 X 4-1/2 HHCS GR. 5 ZP
10	1	2000-201-BLACK	HITCH RECEIVER W.A., BLACK
	1	2000-201-BLUE	HITCH RECEIVER W.A., BLUE
	1	2000-201-GREEN	HITCH RECEIVER W.A., GREEN
11	1	2000-101	HITCH PIN ASS'Y
12	1	2526-501	3/4 STANDARD FLATWASHER ZP
13	2	2565-813	AMBER REFLECTOR
14	1	2565-683	TOWING SPEED DECAL
15	1	2565-684	'HITCH CAPACITY' DECAL
16	1	2565-472	ALL STEER TRANSPORT WARN DECAL



# PARTS IDENTIFICATION

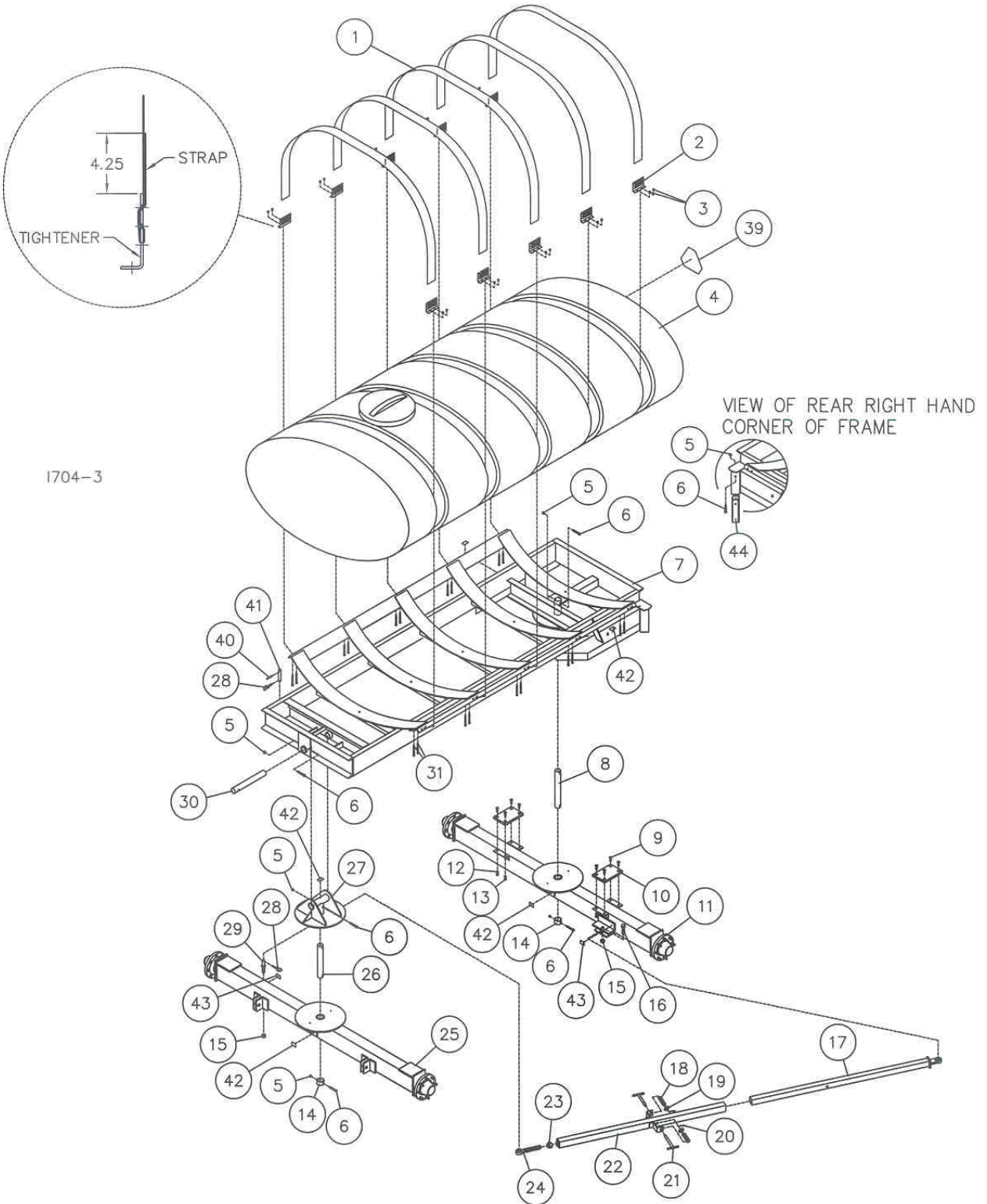

**MANUFACTURED 3-04 TO 6-04**

## PARTS IDENTIFICATION

DET	QTY	PART NO.	DESCRIPTION
1	5	2000-315	4" X 138" NYLON STRAP
2	10	2000-316	TANK STRAP TIGHTENER
3	20	2520-259	3/8-16 LOCK HEX NUT SS
4	1	2515-700	1600 GAL. POLY TANK, WHITE
	1	2515-699	1600 GAL. POLY TANK, YELLOW
5	5	2520-357	1/2-13 LOCK HEX NUT ZP
6	5	2502-313	1/2-13 X 3 HHCS GR. 5 ZP
7	1	2000-203-BLACK	ALL STEER FRAME W.A., BLACK
	1	2000-203-BLUE	ALL STEER FRAME W.A., BLUE
	1	2000-203-GREEN	ALL STEER FRAME W.A., GREEN
8	1	2000-317	REAR PIVOT PIN ZYD.
9	8	2503-352	1/2-13 X 1 1/2 FSHCS ZP
10	2	2000-318	POLY WEAR PAD
11	1	2000-104-BLACK	REAR AXLE ASSEMBLY, BLACK
	1	2000-104-BLUE	REAR AXLE ASSEMBLY, BLUE
	1	2000-104-GREEN	REAR AXLE ASSEMBLY, GREEN
12	8	2525-352	1/2 MED LOCKWASHER ZP
13	8	2520-352	1/2-13 HEX NUT ZP
14	2	2000-319-BLACK	PIVOT COLLAR, BLACK
	2	2000-319-BLUE	PIVOT COLLAR, BLUE
	2	2000-319-GREEN	PIVOT COLLAR, GREEN
15	2	2520-540	7/8-9 LOCK HEX NUT ZP
16	1	2502-606	7/8-9 X 3 HHCS GR5 ZP
17	1	2000-204-BLACK	INNER LINKAGE W.A., BLACK
	1	2000-204-BLUE	INNER LINKAGE W.A., BLUE
	1	2000-204-GREEN	INNER LINKAGE W.A., GREEN
18	2	2550-761	THROW OUT CLUTCH SPRING, BLACK
19	2	2526-501	3/4 STANDARD FLATWASHER ZP
20	2	2530-153	1/4 X 2 ROLL PIN ZP
21	2	2000-205	LOCK PIN W.A. ZYD.
22	1	2000-206-BLACK	OUTER TUBE W.A., BLACK
	1	2000-206-BLUE	OUTER TUBE W.A., BLUE
	1	2000-206-GREEN	OUTER TUBE W.A., GREEN
23	1	2520-573	1 1/4-7 JAM NUT ZP.
24	1	2570-070	BALL JOINT, ROD END
25	1	2000-161-BLACK	FRONT AXLE ASSEMBLY, BLACK
	1	2000-161-BLUE	FRONT AXLE ASSEMBLY, BLUE
	1	2000-161-GREEN	FRONT AXLE ASSEMBLY, GREEN
26	1	2000-320	FRONT PIVOT PIN ZYD.
27	1	2000-208-BLACK	COMPOUND PIVOT W.A., BLACK
	1	2000-208-BLUE	COMPOUND PIVOT W.A., BLUE
	1	2000-208-GREEN	COMPOUND PIVOT W.A., GREEN
28	2	2570-453	KLIK PIN
29	1	2570-378	7/8 LIFT PIN CAT. 1
30	1	2000-321	UPPER PIVOT PIN ZYD.
31	20	2502-255	3/8-16 X 6 SS HHCS
32	3	2565-498	ALL STEER DECAL
33	2	2565-162	YETTER DECAL, 1-1/2 X 4-1/2
34	1	2565-466	SERIAL NUMBER DECAL
35	3	2565-813	AMBER REFLECTOR
36	15	2515-552	CABLE TIE, .15 X 11.5", BLACK
37	1	1300-446	HARNESS, COMMON WIRING
38	1	1300-445	MODULE, IMPLEMENT TURN SIGNAL
39	1	2565-495	SMV DECAL
40	1	2530-208	3/8 X 2-1/2 ROLL PIN ZP
41	1	2000-324	TRANSPORT PIN ZYD.
42	5	2565-496	'GREASE WEEKLY' DECAL
43	2	2565-497	'OIL DAILY' DECAL
44	1	2000-314-BLACK	STOP TUBE, BLACK
	1	2000-314-BLUE	STOP TUBE, BLUE
	1	2000-314-GREEN	STOP TUBE, GREEN

**MANUFACTURED 3-04 TO 6-04**

# PARTS IDENTIFICATION

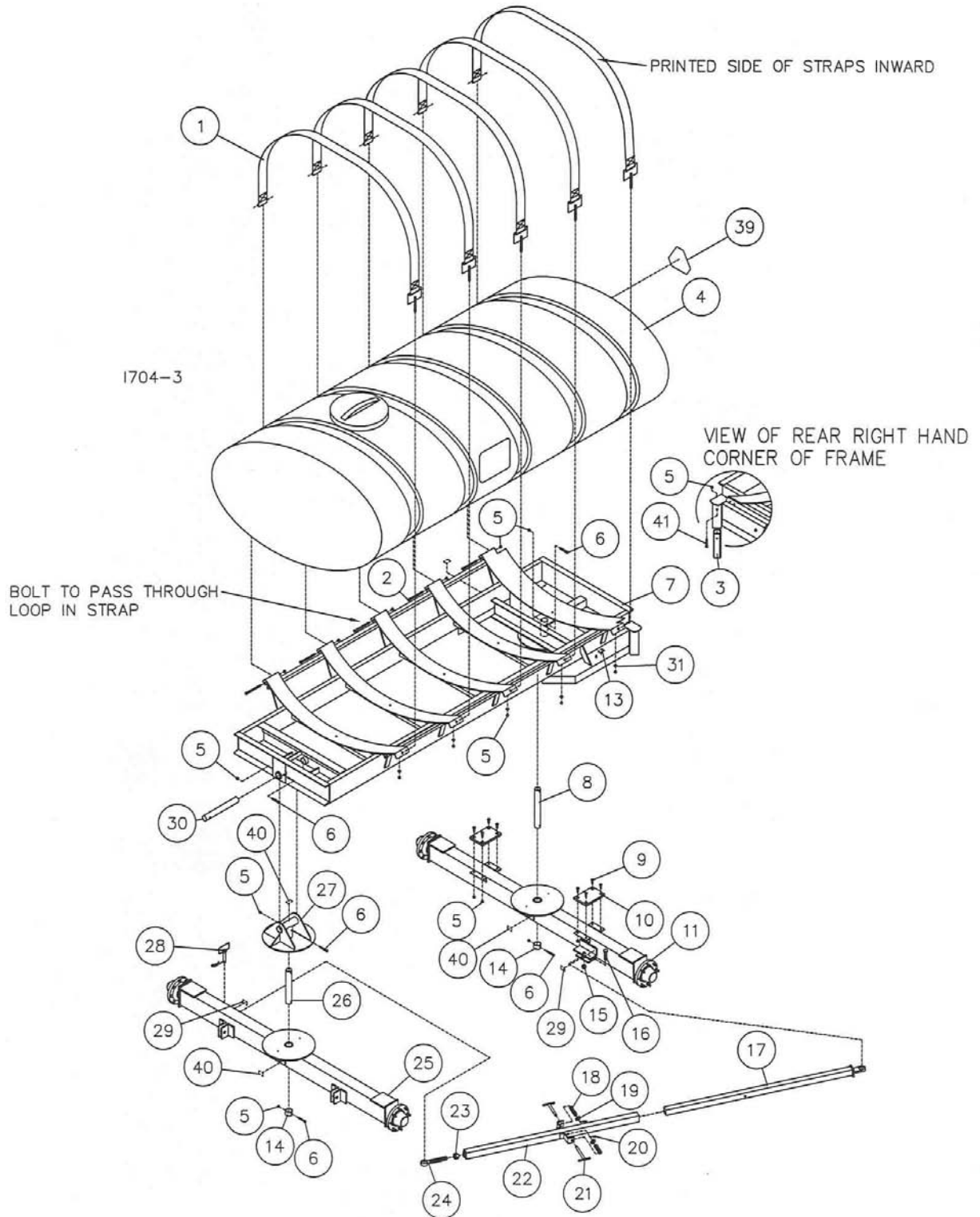

**MANUFACTURED 08-04 TO 08-05**

## PARTS IDENTIFICATION

DET	QTY	PART NO.	DESCRIPTION
1	5	2000-109	STRAP ASSEMBLY
2	5	2502-370	1/2-13 X 7-1/2 HHCS GR 5 ZYD
3	1	2000-314	STOP TUBE
4	1	2515-700	1600 GAL. POLY TANK, WHITE
	1	2515-699	1600 GAL. POLY TANK, YELLOW
5	23	2520-357	1/2-13 LOCK HEX NUT ZP
6	5	2502-313	1/2-13 X 3 HHCS GR. 5 ZP
7	1	2000-203-BLACK	ALL STEER FRAME W.A., BLACK
	1	2000-203-BLUE	ALL STEER FRAME W.A., BLUE
	1	2000-203-GREEN	ALL STEER FRAME W.A., GREEN
8	1	2000-317	REAR PIVOT PIN ZYD.
9	8	2503-352	1/2-13 X 1 1/2 FSHCS ZP
10	2	2000-318	POLY WEAR PAD
11	1	2000-104-BLACK	REAR AXLE ASSEMBLY, BLACK
	1	2000-104-BLUE	REAR AXLE ASSEMBLY, BLUE
	1	2000-104-GREEN	REAR AXLE ASSEMBLY, GREEN
12	8	2525-352	1/2 MED LOCKWASHER ZP
13	8	2520-352	1/2-13 HEX NUT ZP
14	2	2000-319	PIVOT COLLAR, ZYD
15	1	2520-540	7/8-9 LOCK HEX NUT ZP
16	1	2502-606	7/8-9 X 3 HHCS GR5 ZP
17	1	2000-204	INNER LINKAGE W.A.
18	2	2550-761	THROW OUT CLUTCH SPRING, BLACK
19	2	2526-501	3/4 STANDARD FLATWASHER ZP
20	2	2530-153	1/4 X 2 ROLL PIN ZP
21	2	2000-205	LOCK PIN W.A. ZYD.
22	1	2000-206	OUTER TUBE W.A.
23	1	2520-573	1 1/4-7 JAM NUT ZP.
24	1	2570-070	BALL JOINT, ROD END
25	1	2000-161-BLACK	FRONT AXLE ASSEMBLY, BLACK
	1	2000-161-BLUE	FRONT AXLE ASSEMBLY, BLUE
	1	2000-161-GREEN	FRONT AXLE ASSEMBLY, GREEN
26	1	2000-320	FRONT PIVOT PIN ZYD.
27	1	2000-208-BLACK	COMPOUND PIVOT W.A., BLACK
	1	2000-208-BLUE	COMPOUND PIVOT W.A., BLUE
	1	2000-208-GREEN	COMPOUND PIVOT W.A., GREEN
28	1	2000-101	HITCH PIN ASSY, SLOAN #006003
29	2	2565-497	'OIL DAILY' DECAL
30	1	2000-321	UPPER PIVOT PIN ZYD.
31	5	2526-352	1/2 SAE FLAT WASHER ZYD
32	3	2565-498	ALL STEER DECAL
33	2	2565-162	YETTER DECAL, 1-1/2 X 4-1/2
34	1	2565-466	SERIAL NUMBER DECAL
35	3	2565-813	AMBER REFLECTOR
36	15	2515-552	CABLE TIE, .15 X 11.5", BLACK
37	1	1300-446	HARNESS, COMMON WIRING
38	1	1300-445	MODULE, IMPLEMENT TURN SIGNAL
39	1	2565-495	SMV DECAL
40	5	2565-496	'GREASE WEEKLY' DECAL
41	1	2502-316	1/2-13 X 3-1/2 HHCS GR 5 ZYD

**MANUFACTURED 08-04 TO 08-05**

# PARTS IDENTIFICATION

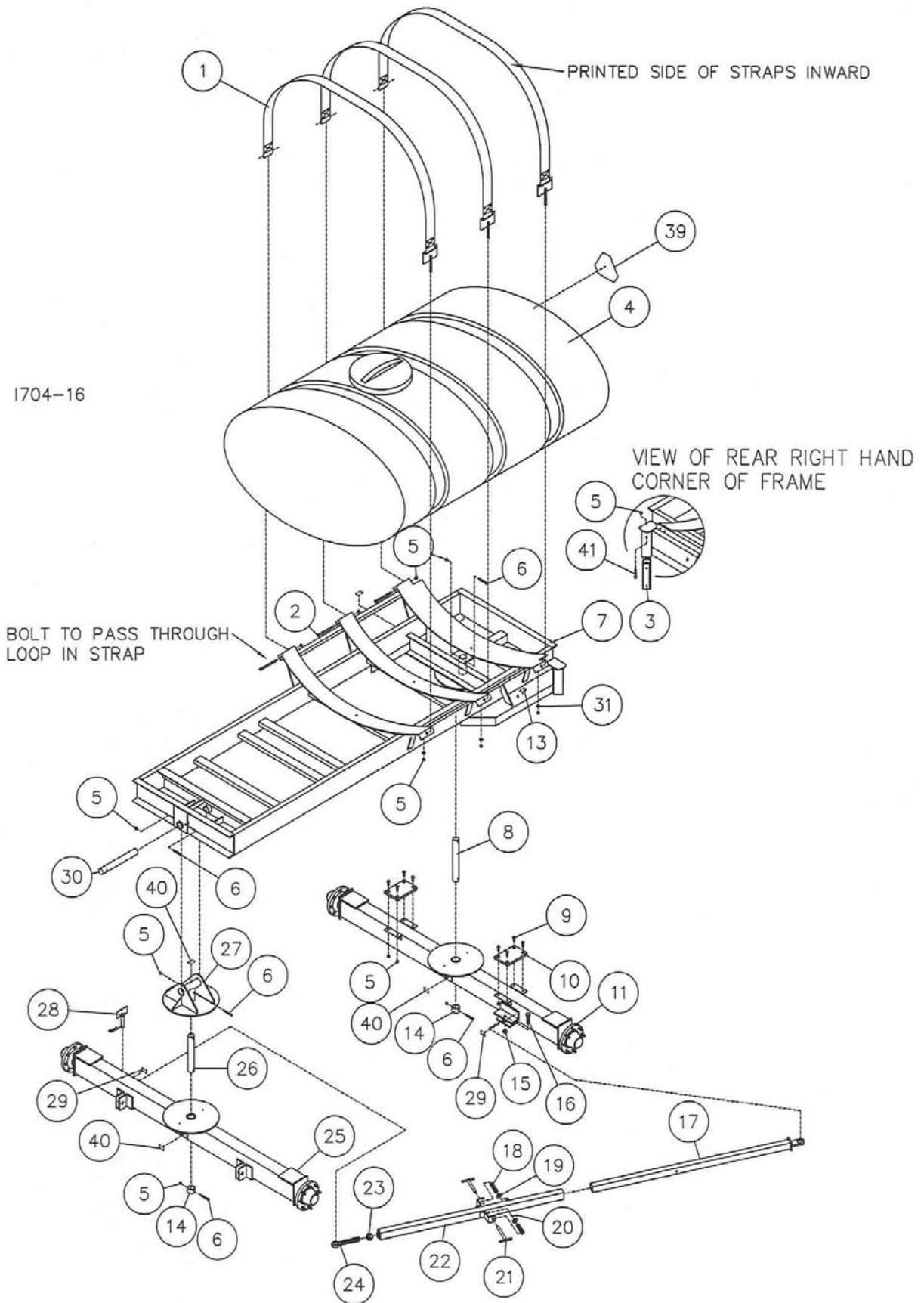

**MANUFACTURED 08-04 TO 08-05**



## PARTS IDENTIFICATION

DET	QTY	PART NO.	DESCRIPTION
1	3	2000-109	STRAP ASSEMBLY
2	3	2502-370	1/2-13 X 7-1/2 HHCS GR 5 ZYD
3	1	2000-314	STOP TUBE
4	1	2515-716	1000 GAL. POLY TANK, WHITE
	1	2515-715	1000 GAL. POLY TANK, YELLOW
5	19	2520-357	1/2-13 LOCK HEX NUT ZP
6	5	2502-313	1/2-13 X 3 HHCS GR. 5 ZP
7	1	2000-227-BLACK	FRAME W/CROSSMEMBER WA, BLACK
	1	2000-227-BLUE	FRAME W/CROSSMEMBER WA, BLUE
	1	2000-227-GREEN	FRAME W/CROSSMEMBER WA, GREEN
8	1	2000-317	REAR PIVOT PIN ZYD.
9	8	2503-352	1/2-13 X 1 1/2 FSHCS ZP
10	2	2000-318	POLY WEAR PAD
11	1	2000-104-BLACK	REAR AXLE ASSEMBLY, BLACK
	1	2000-104-BLUE	REAR AXLE ASSEMBLY, BLUE
	1	2000-104-GREEN	REAR AXLE ASSEMBLY, GREEN
12	8	2525-352	1/2 MED LOCKWASHER ZP
13	8	2520-352	1/2-13 HEX NUT ZP
14	2	2000-319	PIVOT COLLAR, ZYD
15	1	2520-540	7/8-9 LOCK HEX NUT ZP
16	1	2502-606	7/8-9 X 3 HHCS GR5 ZP
17	1	2000-204	INNER LINKAGE W.A.
18	2	2550-761	THROW OUT CLUTCH SPRING, BLACK
19	2	2526-501	3/4 STANDARD FLATWASHER ZP
20	2	2530-153	1/4 X 2 ROLL PIN ZP
21	2	2000-205	LOCK PIN W.A. ZYD.
22	1	2000-206	OUTER TUBE W.A.
23	1	2520-573	1 1/4-7 JAM NUT ZP.
24	1	2570-070	BALL JOINT, ROD END
25	1	2000-161-BLACK	FRONT AXLE ASSEMBLY, BLACK
	1	2000-161-BLUE	FRONT AXLE ASSEMBLY, BLUE
	1	2000-161-GREEN	FRONT AXLE ASSEMBLY, GREEN
26	1	2000-320	FRONT PIVOT PIN ZYD.
27	1	2000-208-BLACK	COMPOUND PIVOT W.A., BLACK
	1	2000-208-BLUE	COMPOUND PIVOT W.A., BLUE
	1	2000-208-GREEN	COMPOUND PIVOT W.A., GREEN
28	1	2000-101	HITCH PIN ASSY, SLOAN #006003
29	2	2565-497	'OIL DAILY' DECAL
30	1	2000-321	UPPER PIVOT PIN ZYD.
31	3	2526-352	1/2 SAE FLAT WASHER ZYD
32	3	2565-498	ALL STEER DECAL
33	2	2565-162	YETTER DECAL, 1-1/2 X 4-1/2
34	1	2565-466	SERIAL NUMBER DECAL
35	3	2565-813	AMBER REFLECTOR
36	15	2515-552	CABLE TIE, .15 X 11.5", BLACK
37	1	1300-446	HARNESS, COMMON WIRING
38	1	1300-445	MODULE, IMPLEMENT TURN SIGNAL
39	1	2565-495	SMV DECAL
40	5	2565-496	'GREASE WEEKLY' DECAL
41	1	2502-316	1/2-13 X 3-1/2 HHCS GR 5 ZYD

**MANUFACTURED 08-04 TO 08-05**

# PARTS IDENTIFICATION

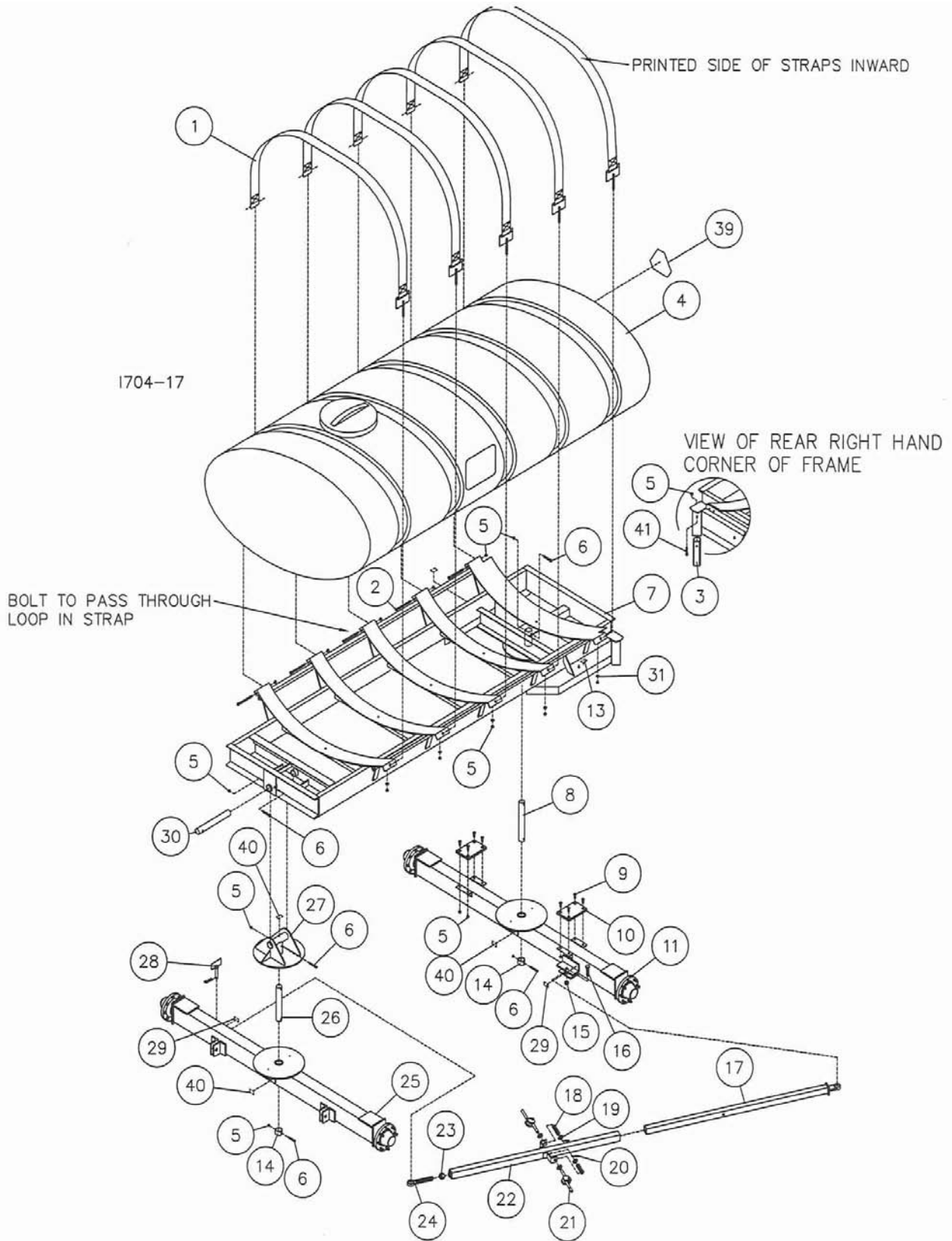

**MANUFACTURED 08-05 TO 07-07**

## PARTS IDENTIFICATION

DET	QTY	PART NO.	DESCRIPTION
1	5	2000-109	STRAP ASSEMBLY
2	5	2502-370	1/2-13 X 7-1/2 HHCS GR 5 ZYD
3	1	2000-314	STOP TUBE
4	1	2515-700	1600 GAL. POLY TANK, WHITE
	1	2515-699	1600 GAL. POLY TANK, YELLOW
5	23	2520-357	1/2-13 LOCK HEX NUT ZP
6	5	2502-313	1/2-13 X 3 HHCS GR. 5 ZP
7	1	2000-203-BLACK	ALL STEER FRAME W.A., BLACK
	1	2000-203-BLUE	ALL STEER FRAME W.A., BLUE
	1	2000-203-GREEN	ALL STEER FRAME W.A., GREEN
8	1	2000-317	REAR PIVOT PIN ZYD.
9	8	2503-352	1/2-13 X 1 1/2 FSHCS ZP
10	2	2000-318	POLY WEAR PAD
11	1	2000-104-BLACK	REAR AXLE ASSEMBLY, BLACK
	1	2000-104-BLUE	REAR AXLE ASSEMBLY, BLUE
	1	2000-104-GREEN	REAR AXLE ASSEMBLY, GREEN
12	8	2525-352	1/2 MED LOCKWASHER ZP
13	8	2520-352	1/2-13 HEX NUT ZP
14	2	2000-319	PIVOT COLLAR, ZYD
15	1	2520-540	7/8-9 LOCK HEX NUT ZP
16	1	2502-606	7/8-9 X 3 HHCS GR5 ZP
17	1	2000-204	INNER LINKAGE W.A.
18	2	2550-761	THROW OUT CLUTCH SPRING, BLACK
19	4	2526-501	3/4 STANDARD FLATWASHER ZP
20	2	2530-153	1/4 X 2 ROLL PIN ZP
21	2	2000-163	CAM LOCK ASSEMBLY
22	1	2000-206	OUTER TUBE W.A.
23	1	2520-573	1 1/4-7 JAM NUT ZP.
24	1	2570-070	BALL JOINT, ROD END
25	1	2000-161-BLACK	FRONT AXLE ASSEMBLY, BLACK
	1	2000-161-BLUE	FRONT AXLE ASSEMBLY, BLUE
	1	2000-161-GREEN	FRONT AXLE ASSEMBLY, GREEN
26	1	2000-320	FRONT PIVOT PIN ZYD.
27	1	2000-208	COMPOUND PIVOT W.A.
28	1	2000-101	HITCH PIN ASSY, SLOAN #006003
29	2	2565-497	'OIL DAILY' DECAL
30	1	2000-321	UPPER PIVOT PIN ZYD.
31	5	2526-352	1/2 SAE FLAT WASHER ZYD
32	3	2565-498	ALL STEER DECAL
33	2	2565-162	YETTER DECAL, 1-1/2 X 4-1/2
34	1	2565-466	SERIAL NUMBER DECAL
35	3	2565-813	AMBER REFLECTOR
36	15	2515-552	CABLE TIE, .15 X 11.5", BLACK
37	1	1300-446	HARNESS, COMMON WIRING
38	1	1300-445	MODULE, IMPLEMENT TURN SIGNAL
39	1	2565-495	SMV DECAL
40	5	2565-496	'GREASE WEEKLY' DECAL
41	1	2502-316	1/2-13 X 3-1/2 HHCS GR 5 ZYD

**MANUFACTURED 08-05 TO 07-07**



# PARTS IDENTIFICATION

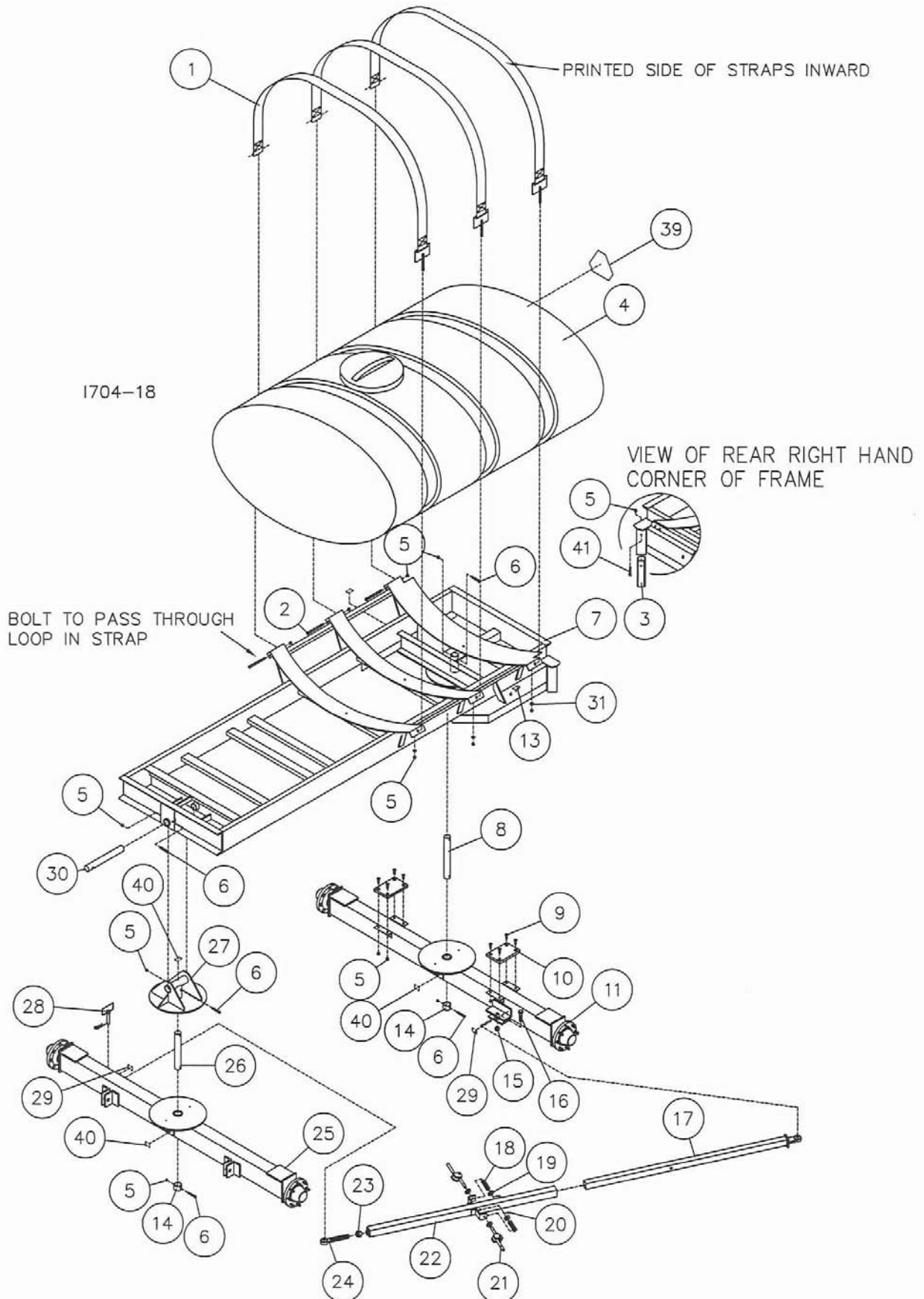

**MANUFACTURED 08-05 TO 07-07**

## PARTS IDENTIFICATION

DET	QTY	PART NO.	DESCRIPTION
1	3	2000-109	STRAP ASSEMBLY
2	3	2502-370	1/2-13 X 7-1/2 HHCS GR 5 ZYD
3	1	2000-314	STOP TUBE
4	1	2515-716	1000 GAL. POLY TANK, WHITE
	1	2515-715	1000 GAL. POLY TANK, YELLOW
5	19	2520-357	1/2-13 LOCK HEX NUT ZP
6	5	2502-313	1/2-13 X 3 HHCS GR. 5 ZP
7	1	2000-227-BLACK	FRAME W/CROSSMEMBER WA, BLACK
	1	2000-227-BLUE	FRAME W/CROSSMEMBER WA, BLUE
	1	2000-227-GREEN	FRAME W/CROSSMEMBER WA, GREEN
8	1	2000-317	REAR PIVOT PIN ZYD.
9	8	2503-352	1/2-13 X 1 1/2 FSHCS ZP
10	2	2000-318	POLY WEAR PAD
11	1	2000-104-BLACK	REAR AXLE ASSEMBLY, BLACK
	1	2000-104-BLUE	REAR AXLE ASSEMBLY, BLUE
	1	2000-104-GREEN	REAR AXLE ASSEMBLY, GREEN
12	8	2525-352	1/2 MED LOCKWASHER ZP
13	8	2520-352	1/2-13 HEX NUT ZP
14	2	2000-319	PIVOT COLLAR, ZYD
15	1	2520-540	7/8-9 LOCK HEX NUT ZP
16	1	2502-606	7/8-9 X 3 HHCS GR5 ZP
17	1	2000-204	INNER LINKAGE W.A.
18	2	2550-761	THROW OUT CLUTCH SPRING, BLACK
19	4	2526-501	3/4 STANDARD FLATWASHER ZP
20	2	2530-153	1/4 X 2 ROLL PIN ZP
21	2	2000-163	CAM LOCK ASSEMBLY
22	1	2000-206	OUTER TUBE W.A.
23	1	2520-573	1 1/4-7 JAM NUT ZP.
24	1	2570-070	BALL JOINT, ROD END
25	1	2000-161-BLACK	FRONT AXLE ASSEMBLY, BLACK
	1	2000-161-BLUE	FRONT AXLE ASSEMBLY, BLUE
	1	2000-161-GREEN	FRONT AXLE ASSEMBLY, GREEN
26	1	2000-320	FRONT PIVOT PIN ZYD.
27	1	2000-208	COMPOUND PIVOT W.A.
28	1	2000-101	HITCH PIN ASSY, SLOAN #006003
29	2	2565-497	'OIL DAILY' DECAL
30	1	2000-321	UPPER PIVOT PIN ZYD.
31	3	2526-352	1/2 SAE FLAT WASHER ZYD
32	3	2565-498	ALL STEER DECAL
33	2	2565-162	YETTER DECAL, 1-1/2 X 4-1/2
34	1	2565-466	SERIAL NUMBER DECAL
35	3	2565-813	AMBER REFLECTOR
36	15	2515-552	CABLE TIE, .15 X 11.5", BLACK
37	1	1300-446	HARNESS, COMMON WIRING
38	1	1300-445	MODULE, IMPLEMENT TURN SIGNAL
39	1	2565-495	SMV DECAL
40	5	2565-496	'GREASE WEEKLY' DECAL
41	1	2502-316	1/2-13 X 3-1/2 HHCS GR 5 ZYD

**MANUFACTURED 08-05 TO 07-07**

# PARTS IDENTIFICATION

## REAR AXLE ASSEMBLY

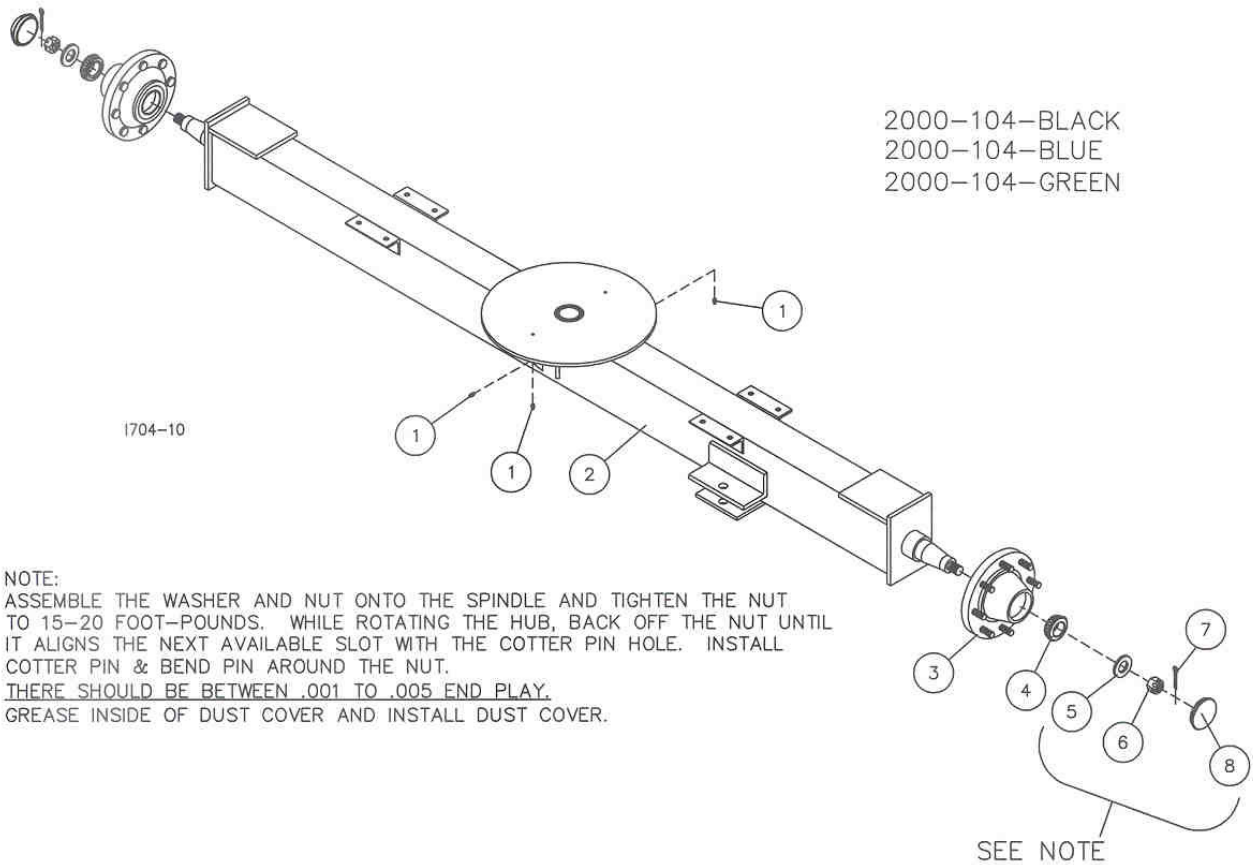

**NOTE:**

ASSEMBLE THE WASHER AND NUT ONTO THE SPINDLE AND TIGHTEN THE NUT TO 15-20 FOOT-POUNDS. WHILE ROTATING THE HUB, BACK OFF THE NUT UNTIL IT ALIGNS THE NEXT AVAILABLE SLOT WITH THE COTTER PIN HOLE. INSTALL COTTER PIN & BEND PIN AROUND THE NUT.

THERE SHOULD BE BETWEEN .001 TO .005 END PLAY.  
GREASE INSIDE OF DUST COVER AND INSTALL DUST COVER.

DET	QTY	PART NO.	DESCRIPTION
1	3	2533-110	1/4-28 ZERK STRAIGHT SELF-TAP
2	1	2000-209	REAR AXLE W.A.
3	2	2000-162	HUB SUB ASSEMBLY
4	2	2550-064	BEARING
5	2	2526-549	WASHER
6	2	2520-567	1-14 UNS CASTLE NUT
7	2	2531-128	COTTER PIN
8	2	2550-065	DUST CAP

**MANUFACTURED 03-04 TO 07-07**

# PARTS IDENTIFICATION

## FRONT AXLE ASSEMBLY

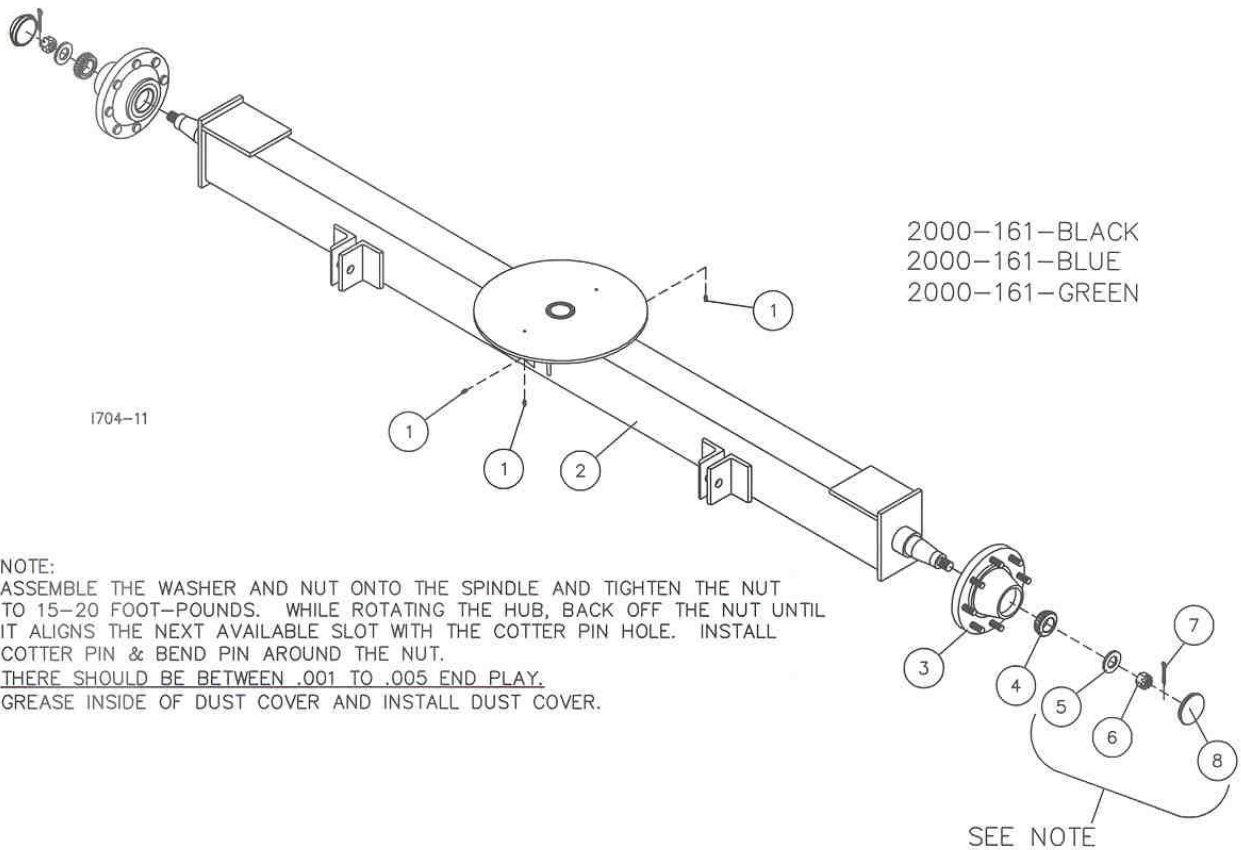

DET	QTY	PART NO.	DESCRIPTION
1	3	2533-110	1/4-28 ZERK STRAIGHT SELF-TAP
2	1	2000-207	FRONT AXLE W.A.
3	2	2000-162	HUB SUB ASSEMBLY
4	2	2550-064	BEARING
5	2	2526-549	WASHER
6	2	2520-567	1-14 UNS CASTLE NUT
7	2	2531-128	COTTER PIN
8	2	2550-065	DUST CAP

**MANUFACTURED 03-04 TO 07-07**

# PARTS IDENTIFICATION

2000-108

1751-2000-108-001

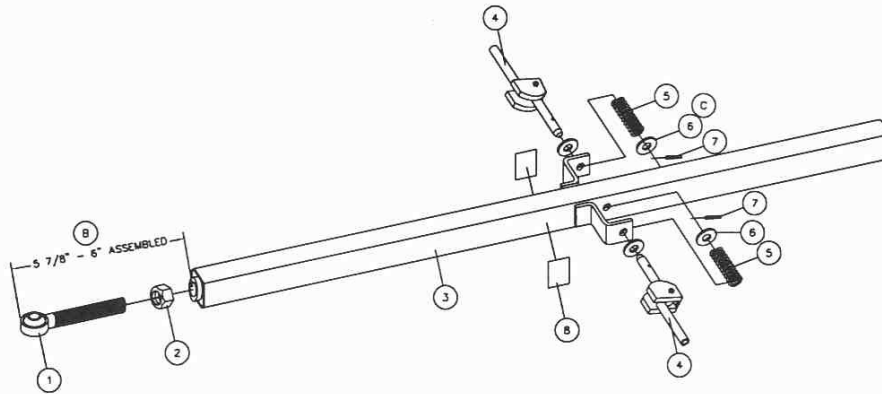

DET	QTY	PART NO.	DESCRIPTION
1	1	2570-070	BALL JOINT
2	1	2520-573	1 1/4-7 JAM NUT
3	1	2000-206	OUTER TUBE
4	2	2000-163	CAM LOCK ASSEMBLY
5	2	2550-761	SPRING
6	4	2526-501	3/4 STANDARD FLATWASHER
7	2	2530-153	1/4 X 2 ROLL PIN
8	2	2565-816	CAM LOCK CAUTION DECAL

**UPDATED 06/10/08**

# PARTS IDENTIFICATION

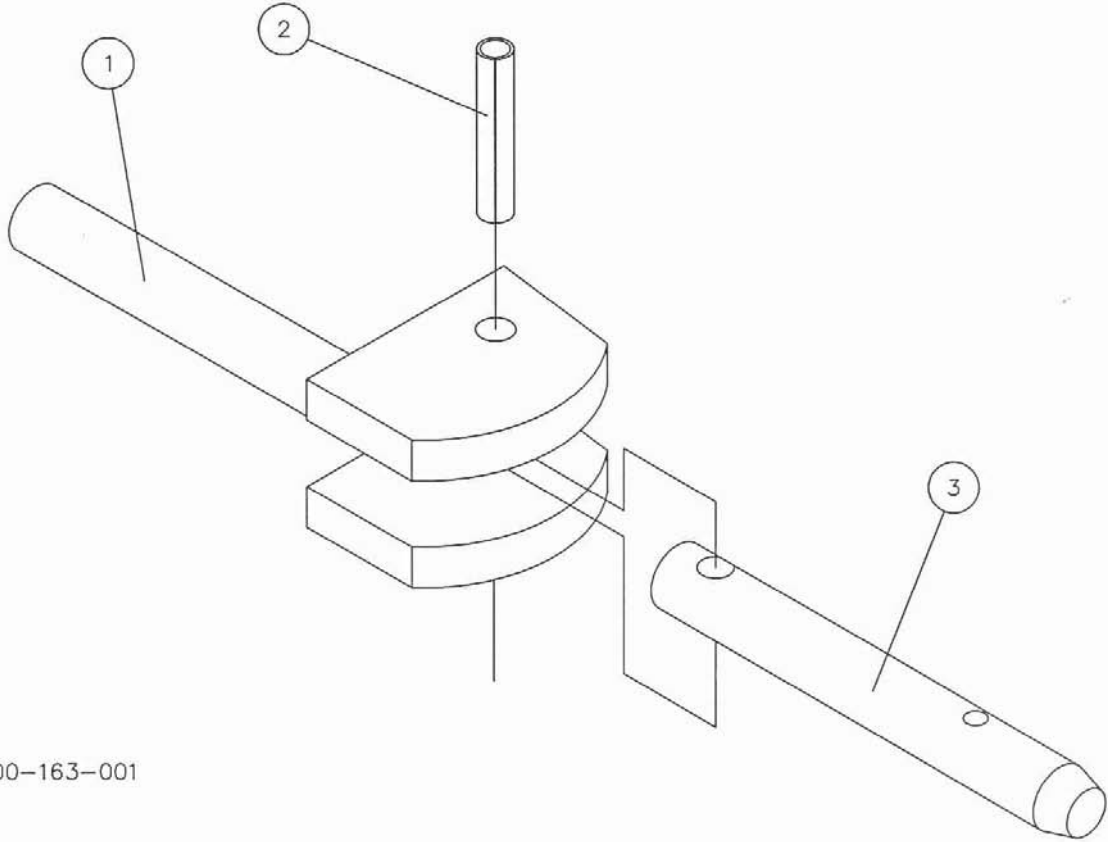

I751-2000-163-001

2000-163 CAM LOCK ASSEMBLY

DET	QTY	PART NO.	DESCRIPTION
1	1	2000-229	CAM LOCK
2	1	2530-212	3/8 X 2 ROLL PIN Z.P.
3	1	2000-388	LOCK PIN

# PARTS IDENTIFICATION

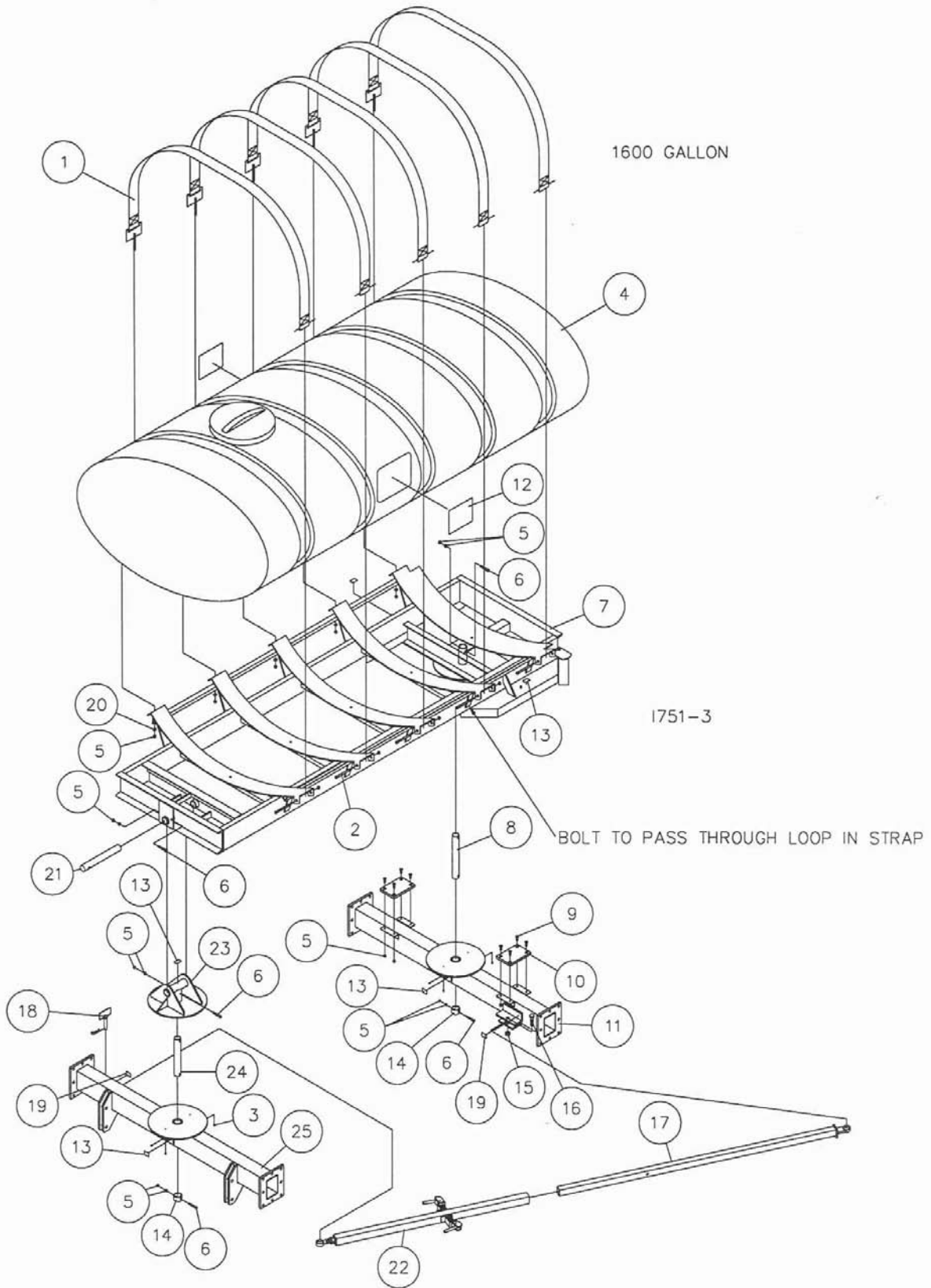

**MANUFACTURED 08-07 TO 01-08**

## PARTS IDENTIFICATION

1600 GALLON

DET	QTY	PART NO.	DESCRIPTION
	1	5	2000-109 STRAP ASSEMBLY
	2	5	2502-370 1/2-13 X 7-1/2 HHCS GR 5 ZYD
	3	6	2533-110 1/4-28 ZERK STRAIGHT SELF-TAP
		1	2515-699 1600 GAL. POLY TANK, YELLOW (GREEN ONLY)
	4	1	2515-700 1600 GAL. POLY TANK, WHITE (BLACK & BLUE)
	5	28	2520-357 1/2-13 LOCK HEX NUT ZP
	6	5	2502-316 1/2-13 X 3-1/2 HHCS GR. 5 ZP
*	7	1	2000-225-BLACK 1600 GAL. FRAME W.A., BLACK
	8	1	2000-317 REAR PIVOT PIN ZYD.
	9	8	2503-352 1/2-13 X 1 1/2 FSHCS ZP
	10	2	2000-318 POLY WEAR PAD
*	11	1	2000-280-BLACK REAR AXLE WA BLACK
	12	2	2565-499 ALL STEER TANK DECAL
	13	5	2565-496 'GREASE WEEKLY' DECAL
*	14	2	2000-319 PIVOT COLLAR ZYD.
	15	1	2520-540 7/8-9 LOCK HEX NUT ZP
	16	1	2502-606 7/8-9 X 3 HHCS GR5 ZP
	17	1	2000-204 INNER LINKAGE W.A.
	18	1	2000-101 HITCH PIN ASSY, SLOAN #006003
	19	2	2565-497 'OIL DAILY' DECAL
	20	5	2526-352 1/2 SAE FLATWASHER ZP
	21	1	2000-321 UPPER PIVOT PIN ZYD.
	22	1	2000-108 LINKAGE SUB-ASS'Y
	23	1	2000-208 COMPOUND PIVOT W.A.
	24	1	2000-320 FRONT PIVOT PIN ZYD.
*	25	1	2000-278-BLACK FRONT AXLE WA BLACK

\* SUBSTITUTE -BLUE AND -GREEN FOR BLUE AND GREEN MODELS

**MANUFACTURED 08-07 TO 01-08**



# PARTS IDENTIFICATION

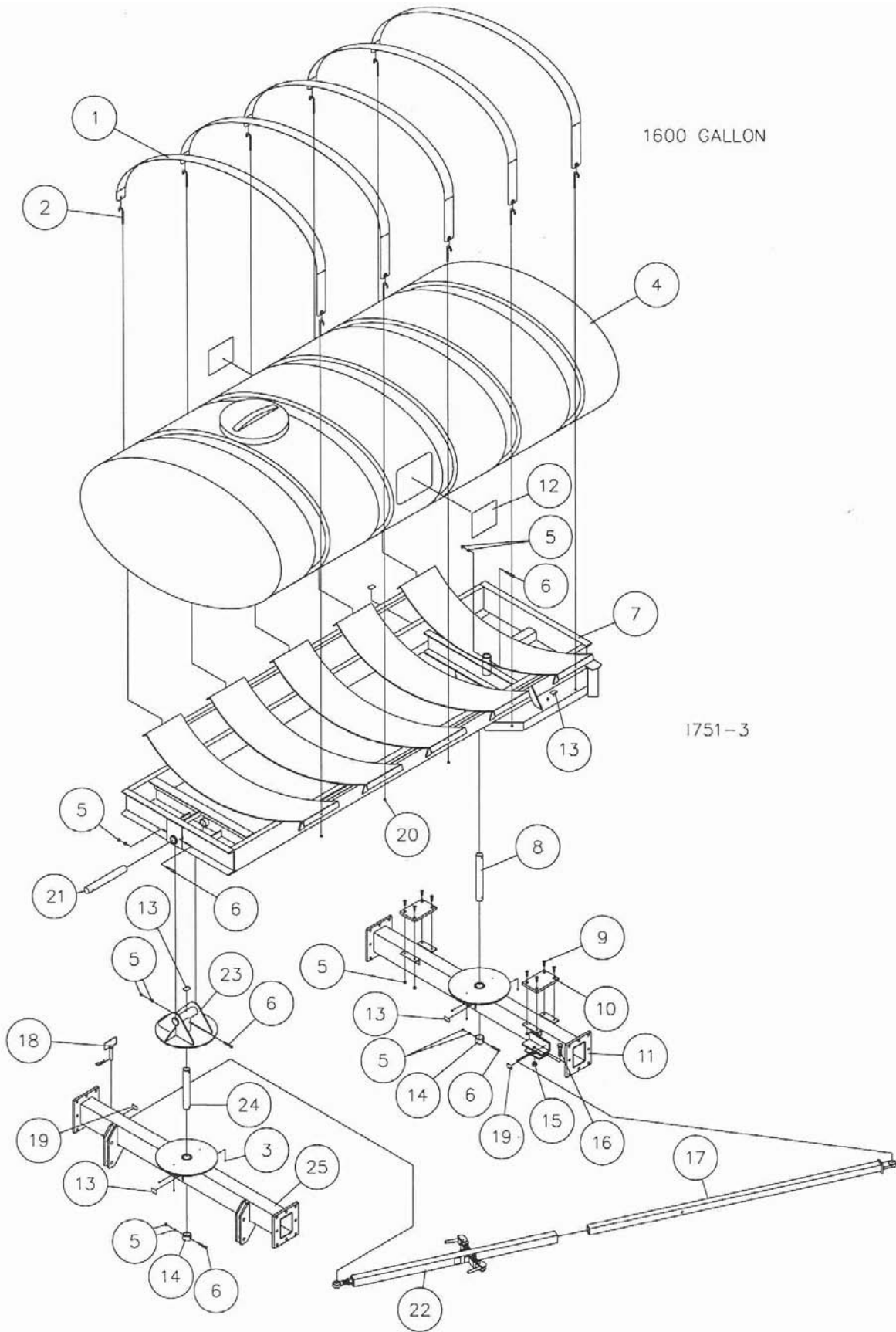

**MANUFACTURED 02-08 TO PRESENT**

# PARTS IDENTIFICATION

1600 GALLON

DET	QTY	PART NO.	DESCRIPTION
	1	5	2000-530 HE1600-SBPS 1600 GA STEEL BAND
	2	10	2570-511 3/8-16 X 6 J-BOLT ZYD
	3	6	2533-110 1/4-28 ZERK STRAIGHT SELF-TAP
		1	2515-699 1600 GAL. POLY TANK, YELLOW (GREEN ONLY)
	4	1	2515-700 1600 GAL. POLY TANK, WHITE (BLACK & BLUE)
	5	18	2520-357 1/2-13 LOCK HEX NUT ZP
	6	5	2502-316 1/2-13 X 3-1/2 HHCS GR. 5 ZP
*	7	1	2000-288-BLACK 1600 A.S. FRAME WA 12/07
	8	1	2000-317 REAR PIVOT PIN ZYD.
	9	8	2503-352 1/2-13 X 1 1/2 FSHCS ZP
	10	2	2000-318 POLY WEAR PAD
*	11	1	2000-280-BLACK REAR AXLE WA BLACK
	12	2	2565-499 ALL STEER TANK DECAL
	13	5	2565-496 'GREASE WEEKLY' DECAL
*	14	2	2000-319 PIVOT COLLAR ZYD.
	15	1	2520-540 7/8-9 LOCK HEX NUT ZP
	16	1	2502-606 7/8-9 X 3 HHCS GR5 ZP
	17	1	2000-204 INNER LINKAGE W.A.
	18	1	2000-101 HITCH PIN ASSY, SLOAN #006003
	19	2	2565-497 'OIL DAILY' DECAL
	20	10	2520-251 3/8-16 HEX NUT ZP
	21	1	2000-321 UPPER PIVOT PIN ZYD.
	22	1	2000-108 LINKAGE SUB-ASS'Y
	23	1	2000-208 COMPOUND PIVOT W.A.
	24	1	2000-320 FRONT PIVOT PIN ZYD.
*	25	1	2000-278-BLACK FRONT AXLE WA BLACK

\* SUBSTITUTE -BLUE AND -GREEN FOR BLUE AND GREEN MODELS

**MANUFACTURED 02-08 TO PRESENT**

# PARTS IDENTIFICATION

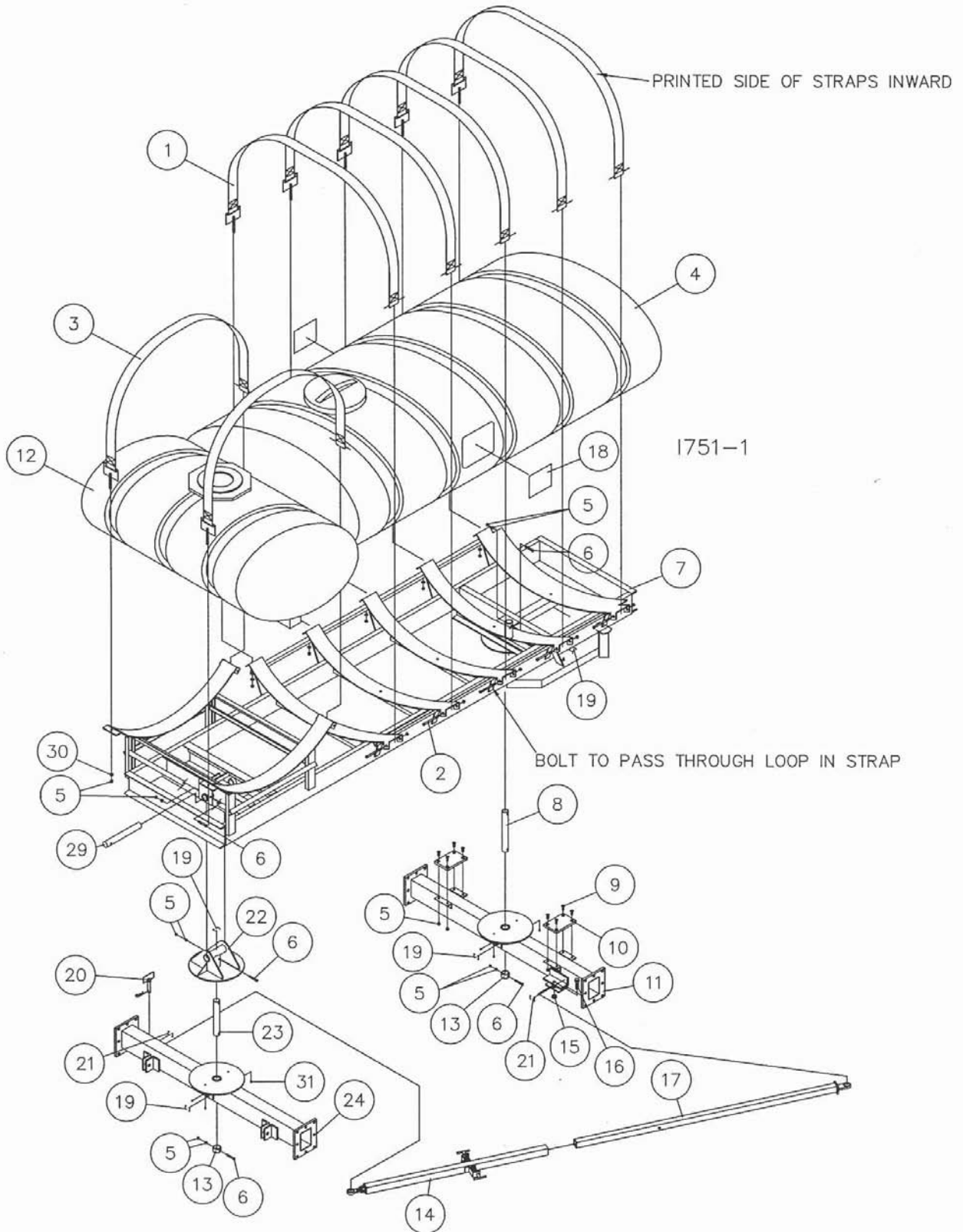

**MANUFACTURED 08-07 TO 01-08**

# PARTS IDENTIFICATION

1600/400 GALLON

DET	QTY	PART NO.	DESCRIPTION
	1	5	2000-109 STRAP ASSEMBLY
	2	7	2502-370 1/2-13 X 7-1/2 HHCS GR 5 ZYD
	3	2	2000-133 STRAP ASS'Y
		1	2515-699 1600 GAL. POLY TANK, YELLOW (GREEN ONLY)
	4	1	2515-700 1600 GAL. POLY TANK, WHITE (BLACK & BLUE)
	5	30	2520-357 1/2-13 LOCK HEX NUT ZP
	6	5	2502-316 1/2-13 X 3-1/2 HHCS GR. 5 ZP
*	7	1	2000-259-BLACK FRAME WA, 2000 DUAL TANK, BLACK
	8	1	2000-317 REAR PIVOT PIN ZYD.
	9	8	2503-352 1/2-13 X 1 1/2 FSHCS ZP
	10	2	2000-318 POLY WEAR PAD
*	11	1	2000-280-BLACK REAR AXLE WA BLACK
		1	2515-723 400 GAL. POLY TANK, YELLOW (GREEN ONLY)
	12	1	2515-722 400 GAL. POLY TANK, WHITE (BLACK & BLUE)
*	13	2	2000-319 PIVOT COLLAR ZYD.
	14	1	2000-108 LINKAGE SUB-ASS'Y
	15	1	2520-540 7/8-9 LOCK HEX NUT ZP
	16	1	2502-606 7/8-9 X 3 HHCS GR5 ZP
	17	1	2000-260 INNER LINKAGE W.A., 2000 DUAL
	18	2	2565-499 ALL STEER TANK DECAL
	19	5	2565-496 'GREASE WEEKLY' DECAL
	20	1	2000-101 HITCH PIN ASSY, SLOAN #006003
	21	2	2565-497 'OIL DAILY' DECAL
*	22	1	2000-208 COMPOUND PIVOT W.A., BLACK
	23	1	2000-320 FRONT PIVOT PIN ZYD.
*	24	1	2000-278-BLACK FRONT AXLE WA BLACK
		3	2565-473 ALL STEER DECAL, YELLOW(2000-010-GREEN)
	25	3	2565-498 ALL STEER DECAL
		1	2565-698 YETTER DECAL, 1.5X4.5, YELLOW(-GREEN)
	26	1	2565-162 YETTER DECAL, 1-1/2 X 4-1/2
	27	1	2565-466 SERIAL NUMBER DECAL
	28	2	2565-813 USE JD5921 AMBER REFLECTOR
	29	1	2000-321 UPPER PIVOT PIN ZYD.
	30	7	2526-352 1/2 SAE FLATWASHER ZP
	31	6	2533-110 1/4-28 ZERK STRAIGHT SELF-TAP

\* SUBSTITUTE -BLUE AND -GREEN FOR BLUE AND GREEN MODELS

**MANUFACTURED 08-07 TO 01-08**

# PARTS IDENTIFICATION

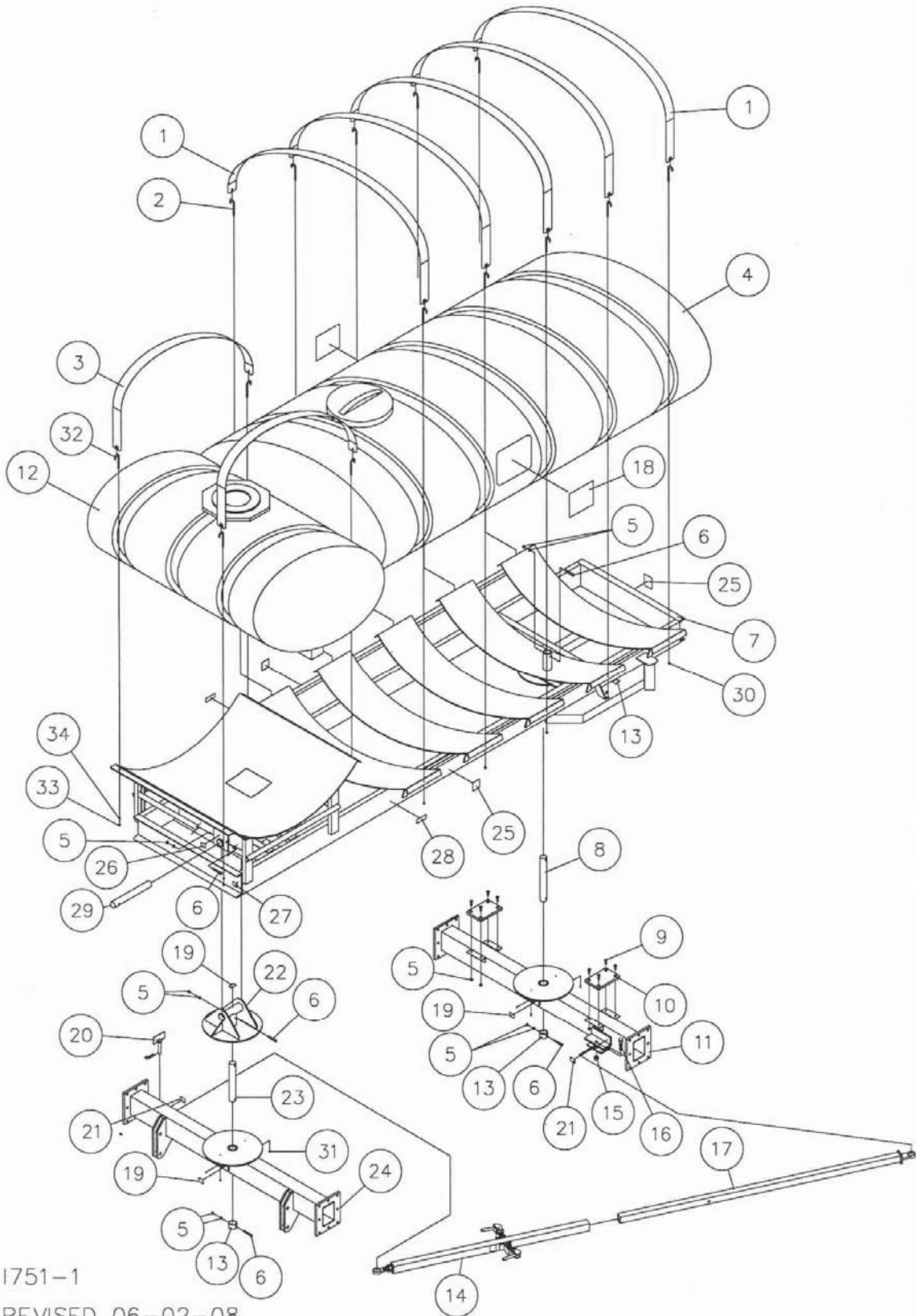

I751-1  
REVISED 06-02-08

**MANUFACTURED 02-08 TO PRESENT**

## PARTS IDENTIFICATION

2000-025 1600/400 GALLON

DET	QTY	PART NO.	DESCRIPTION
	1	5	2000-530 HE1600-SBPS 1600 GA STEEL BAND
	2	10	2570-511 3/8-16 X 6 J-BOLT ZYD
	3	2	2000-531 HE400/500-SBPS 400 GA STL BAND
	4	1	2515-699 1600 GAL. POLY TANK, YELLOW (GREEN ONLY)
		1	2515-700 1600 GAL. POLY TANK, WHITE (BLACK & BLUE)
	5	16	2520-357 1/2-13 LOCK HEX NUT ZP
	6	5	2502-316 1/2-13 X 3-1/2 HHCS GR. 5 ZP
*	7	1	2000-259-BLACK FRAME WA,2000 DUAL TANK,BLACK
	8	1	2000-317 REAR PIVOT PIN ZYD.
	9	8	2503-352 1/2-13 X 1 1/2 FSHCS ZP
	10	2	2000-318 POLY WEAR PAD
*	11	1	2000-280-BLACK REAR AXLE WA BLACK
	12	1	2515-723 400 GAL. POLY TANK, YELLOW (GREEN ONLY)
		1	2515-722 400 GAL. POLY TANK, WHITE (BLACK & BLUE)
*	13	2	2000-319 PIVOT COLLAR ZYD.
	14	1	2000-108 LINKAGE SUB-ASS'Y
	15	1	2520-540 7/8-9 LOCK HEX NUT ZP
	16	1	2502-606 7/8-9 X 3 HHCS GR5 ZP
	17	1	2000-260 INNER LINKAGE W.A., 2000 DUAL
	18	2	2565-499 ALL STEER TANK DECAL
	19	5	2565-496 'GREASE WEEKLY' DECAL
	20	1	2000-101 HITCH PIN ASSY, SLOAN #006003
	21	2	2565-497 'OIL DAILY' DECAL
*	22	1	2000-208 COMPOUND PIVOT W.A., BLACK
	23	1	2000-320 FRONT PIVOT PIN ZYD.
*	24	1	2000-278-BLACK FRONT AXLE WA BLACK
	25	3	2565-473 ALL STEER DECAL, YELLOW(2000-010-GREEN)
		3	2565-498 ALL STEER DECAL
	26	1	2565-698 YETTER DECAL,1.5X4.5, YELLOW(-GREEN)
		1	2565-162 YETTER DECAL, 1-1/2 X 4-1/2
	27	1	2565-466 SERIAL NUMBER DECAL
	28	2	2565-813 USE JD5921 AMBER REFLECTOR
	29	1	2000-321 UPPER PIVOT PIN ZYD.
	30	10	2520-251 3/8-16 HEX NUT ZP
	31	6	2533-110 1/4-28 ZERK STRAIGHT SELF-TAP
	32	4	2570-775 5/16-18X3.75 HOOK BOLT GR 5 ZP
	33	4	2520-201 5/16-18 HEX NUT ZP
	34	4	2526-201 5/16 STANDARD FLATWASHER ZP

\* SUBSTITUTE -BLUE AND -GREEN FOR BLUE AND GREEN MODELS

**MANUFACTURED 02-08 TO PRESENT**

# PARTS IDENTIFICATION

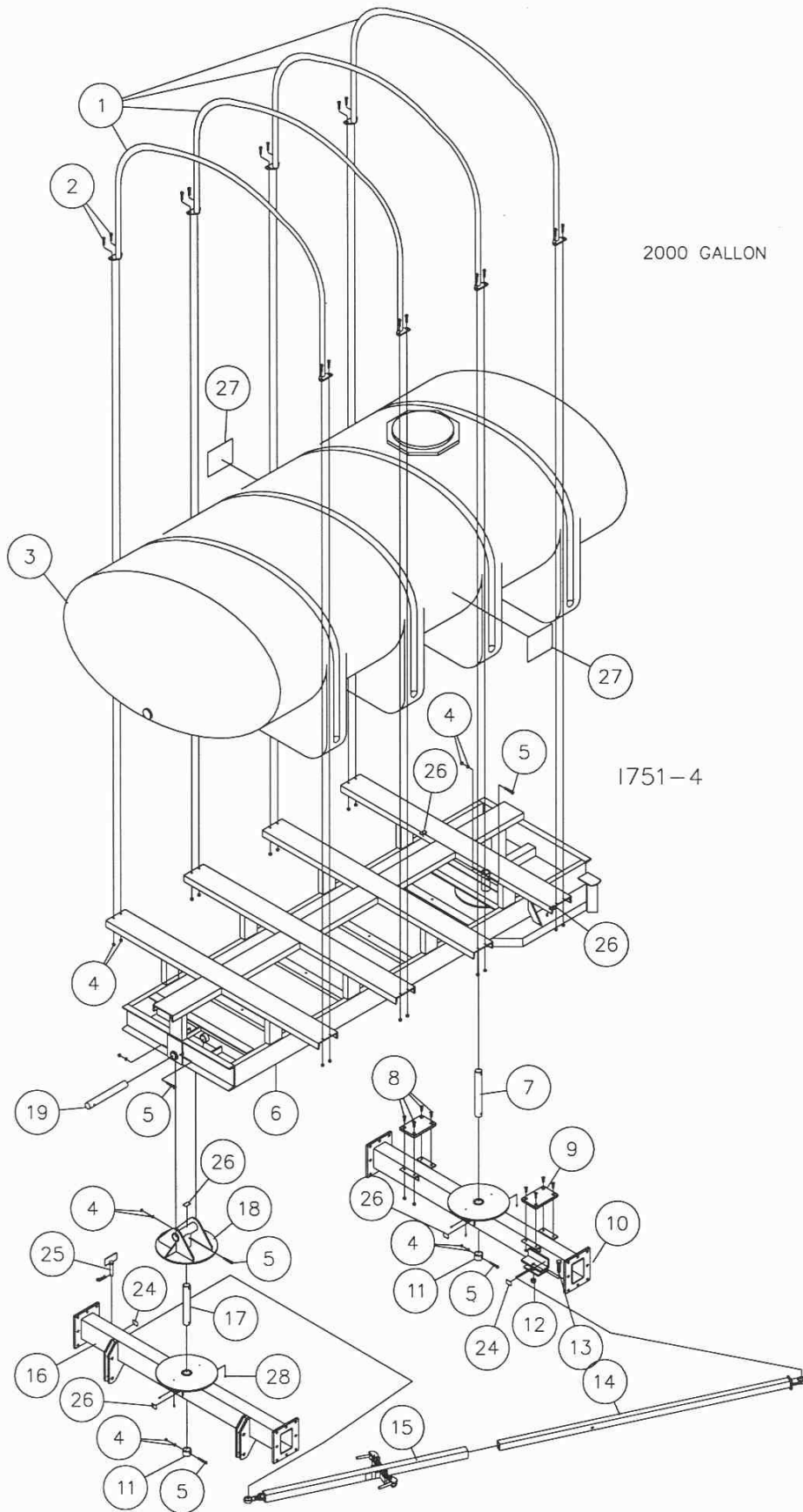

**MANUFACTURED 08-07 TO PRESENT**

## PARTS IDENTIFICATION

2000 GALLON

DET	QTY	PART NO.	DESCRIPTION
	1	4	2000-487 BAND, 2035 GAL. LEG TANK
	2	16	2502-346 1/2-13 X 2 FULL THD HHCS GR 5
		1	2515-725 2035 GAL. POLY TANK, YELLOW (GREEN ONLY)
	3	1	2515-724 2035 GAL. POLY TANK, WHITE (BLACK & BLUE)
	4	34	2520-357 1/2-13 LOCK HEX NUT ZP
	5	5	2502-316 1/2-13 X 3-1/2 HHCS GR. 5 ZP
*	6	1	2000-265-BLACK 2000 GAL. FRAME W.A., BLACK
	7	1	2000-317 REAR PIVOT PIN ZYD.
	8	8	2503-352 1/2-13 X 1 1/2 FSHCS ZP
	9	2	2000-318 POLY WEAR PAD
*	10	1	2000-280-BLACK REAR AXLE WA BLACK
	11	2	2000-319 PIVOT COLLAR ZYD.
	12	1	2520-540 7/8-9 LOCK HEX NUT ZP
	13	1	2502-606 7/8-9 X 3 HHCS GR5 ZP
	14	1	2000-204 INNER LINKAGE W.A.
	15	1	2000-108 LINKAGE SUB-ASS'Y
*	16	1	2000-278-BLACK FRONT AXLE WA BLACK
	17	1	2000-320 FRONT PIVOT PIN ZYD.
	18	1	2000-208 COMPOUND PIVOT W.A.
	19	1	2000-321 UPPER PIVOT PIN ZYD.
		3	2565-473 ALL STEER DECAL, YELLOW(2000-010-GREEN)
	20	3	2565-498 ALL STEER DECAL
		1	2565-698 YETTER DECAL,1.5X4.5, YELLOW(-GREEN)
	21	1	2565-162 YETTER DECAL, 1-1/2 X 4-1/2
	22	1	2565-466 SERIAL NUMBER DECAL
	23	2	2565-813 USE JD5921 AMBER REFLECTOR
	24	2	2565-497 'OIL DAILY' DECAL
	25	1	2000-101 HITCH PIN ASSY, SLOAN #006003
	26	5	2565-496 'GREASE WEEKLY' DECAL
	27	2	2565-499 ALL STEER TANK DECAL
	28	6	2533-110 1/4-28 ZERK STRAIGHT SELF-TAP

\* SUBSTITUTE -BLUE AND -GREEN FOR BLUE AND GREEN MODELS

**MANUFACTURED 08-07 TO PRESENT**



# PARTS IDENTIFICATION

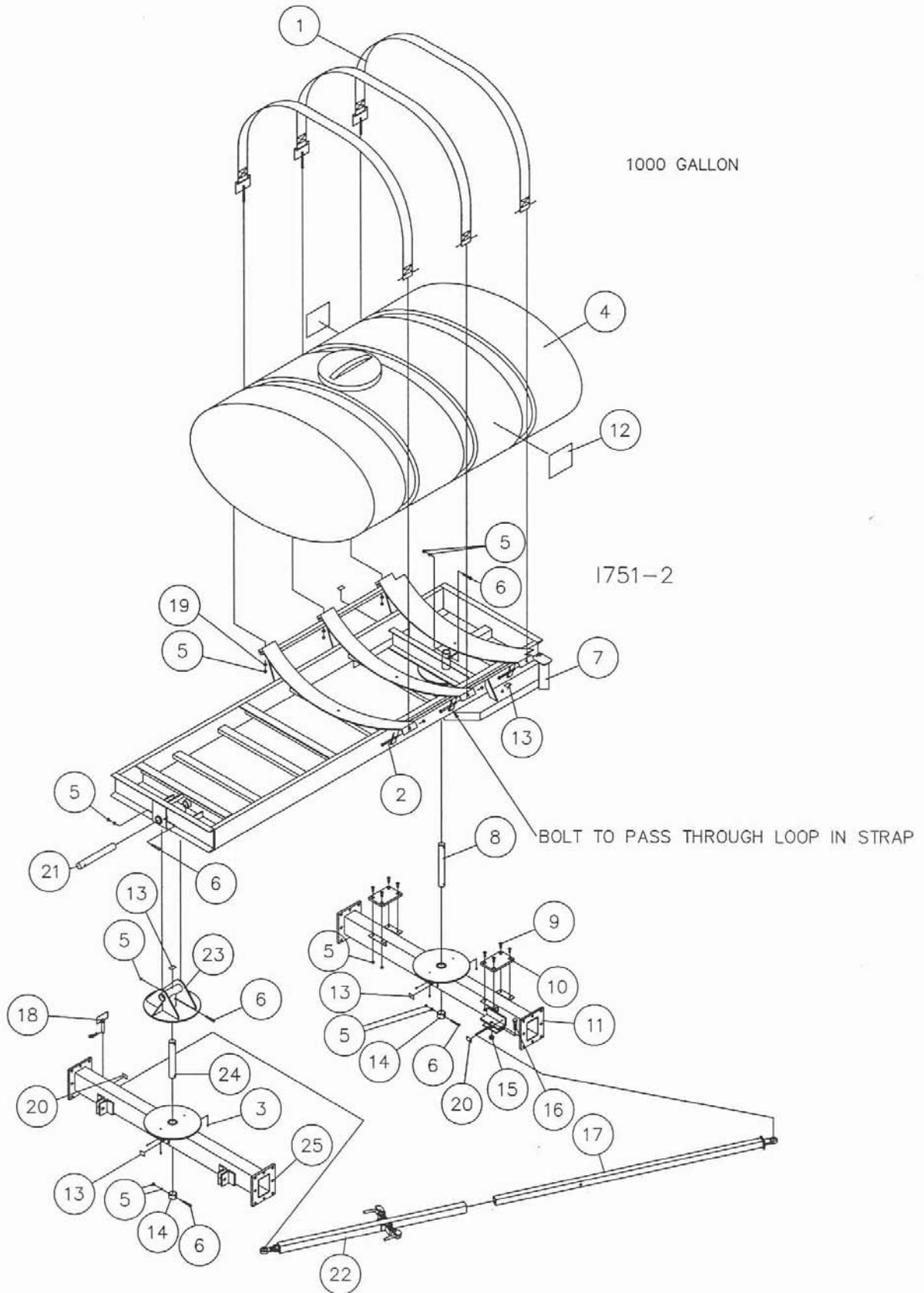

**MANUFACTURED 08-07 TO 01-08**

## PARTS IDENTIFICATION

1000 GALLON

DET	QTY	PART NO.	DESCRIPTION
	1	3	2000-109 STRAP ASSEMBLY
	2	3	2502-370 1/2-13 X 7-1/2 HHCS GR 5 ZYD
	3	6	2533-110 1/4-28 ZERK STRAIGHT SELF-TAP
		1	2515-715 1000 GAL. POLY TANK, YELLOW (GREEN ONLY)
	4	1	2515-716 1000 GAL. POLY TANK, WHITE (BLACK & BLUE)
	5	24	2520-357 1/2-13 LOCK HEX NUT ZP
	6	5	2502-316 1/2-13 X 3-1/2 HHCS GR. 5 ZP
*	7	1	2000-227-BLACK FRAME W/CROSSMEMBER WA, BLACK
	8	1	2000-317 REAR PIVOT PIN ZYD.
	9	8	2503-352 1/2-13 X 1 1/2 FSHCS ZP
	10	2	2000-318 POLY WEAR PAD
*	11	1	2000-280-BLACK REAR AXLE WA BLACK
	12	2	2565-499 ALL STEER TANK DECAL
	13	5	2565-496 'GREASE WEEKLY' DECAL
*	14	2	2000-319 PIVOT COLLAR ZYD.
	15	1	2520-540 7/8-9 LOCK HEX NUT ZP
	16	1	2502-606 7/8-9 X 3 HHCS GR5 ZP
	17	1	2000-204 INNER LINKAGE W.A.
	18	1	2000-101 HITCH PIN ASSY, SLOAN #006003
	19	3	2526-352 1/2 SAE FLATWASHER ZP
	20	2	2565-497 'OIL DAILY' DECAL
	21	1	2000-321 UPPER PIVOT PIN ZYD.
	22	1	2000-108 LINKAGE SUB-ASS'Y
	23	1	2000-208 COMPOUND PIVOT W.A.
	24	1	2000-320 FRONT PIVOT PIN ZYD.
*	25	1	2000-278-BLACK FRONT AXLE WA BLACK

\*SUBSTITUTE -BLUE AND -GREEN FOR BLUE AND GREEN MODELS

**MANUFACTURED 08-07 TO 01-08**

# PARTS IDENTIFICATION

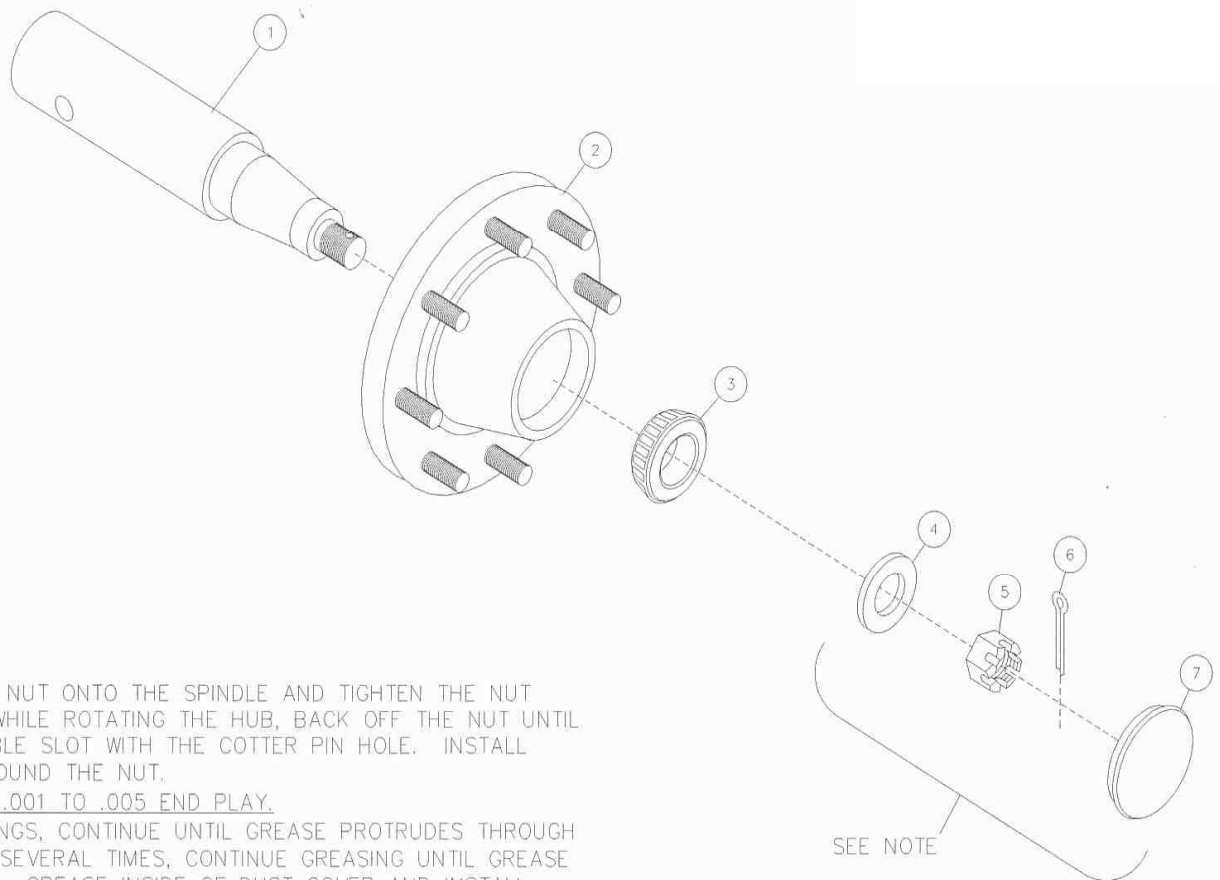

NOTE:  
 ASSEMBLE THE WASHER AND NUT ONTO THE SPINDLE AND TIGHTEN THE NUT TO 15-20 FOOT-POUNDS. WHILE ROTATING THE HUB, BACK OFF THE NUT UNTIL IT ALIGNS THE NEXT AVAILABLE SLOT WITH THE COTTER PIN HOLE. INSTALL COTTER PIN & BEND PIN AROUND THE NUT.  
THERE SHOULD BE BETWEEN .001 TO .005 END PLAY.  
 USE ZERK TO GREASE BEARINGS, CONTINUE UNTIL GREASE PROTRUDES THROUGH OUTER BEARING. SPIN HUB SEVERAL TIMES, CONTINUE GREASING UNTIL GREASE REACHES DUST COVER BORE. GREASE INSIDE OF DUST COVER AND INSTALL.

## 2000-166

DET	QTY	PART NO.	DESCRIPTION
1	1	2000-533	SPINDLE, CROSS-DRILLED 2-3/4"
2	1	2000-162	HUB ASSEMBLY, ALL STEER
3	1	2550-064	OUTER BEARING #N910273
4	1	2526-549	SPINDLE WASHER #913624
5	1	2520-567	1-14 UNS CASTLE NUT CTD #WB33
6	1	2531-128	COTTER PIN #N905941
7	1	2550-065	DUST CAP #909912

## PARTS IDENTIFICATION

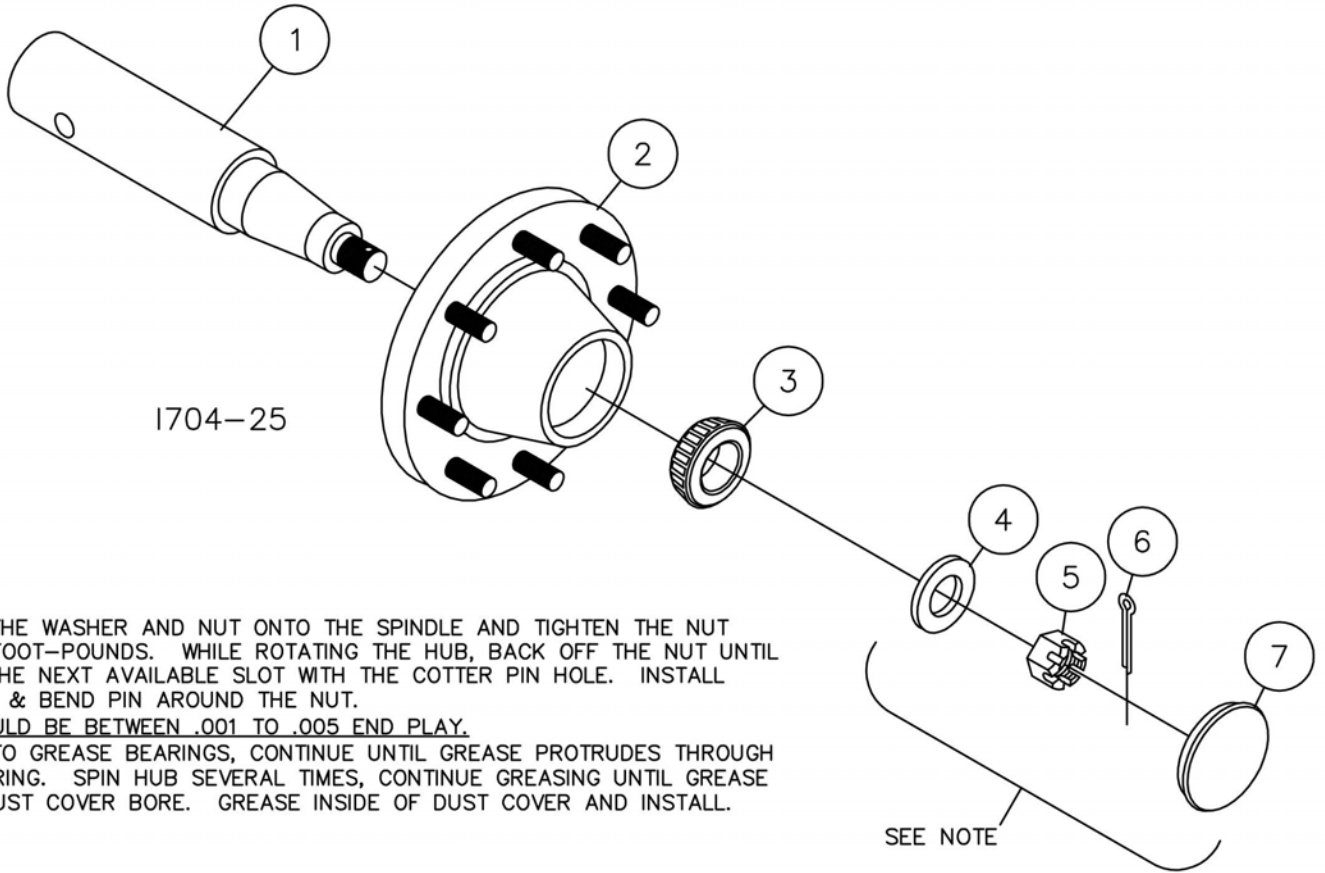

NOTE:  
 ASSEMBLE THE WASHER AND NUT ONTO THE SPINDLE AND TIGHTEN THE NUT TO 15-20 FOOT-POUNDS. WHILE ROTATING THE HUB, BACK OFF THE NUT UNTIL IT ALIGNS THE NEXT AVAILABLE SLOT WITH THE COTTER PIN HOLE. INSTALL COTTER PIN & BEND PIN AROUND THE NUT.  
THERE SHOULD BE BETWEEN .001 TO .005 END PLAY.  
 USE ZERK TO GREASE BEARINGS, CONTINUE UNTIL GREASE PROTRUDES THROUGH OUTER BEARING. SPIN HUB SEVERAL TIMES, CONTINUE GREASING UNTIL GREASE REACHES DUST COVER BORE. GREASE INSIDE OF DUST COVER AND INSTALL.

SEE NOTE

### 2000-157 - 75-8 HUB ASSEMBLY

DET	QTY	PART NO.	DESCRIPTION
1	1	2000-535	SPINDLE, CROSS-DRILLED 3"
2	1	2000-156	75-8 HUB SUB ASSEMBLY
3	1	2550-064	OUTER BEARING #N910273
4	1	2526-549	SPINDLE WASHER #913624
5	1	2520-567	1-14 UNS CASTLE NUT CTD #WB33
6	1	2531-128	COTTER PIN #N905941
7	1	2550-065	DUST CAP #N909912

12-09 TO PRESENT

## PARTS IDENTIFICATION

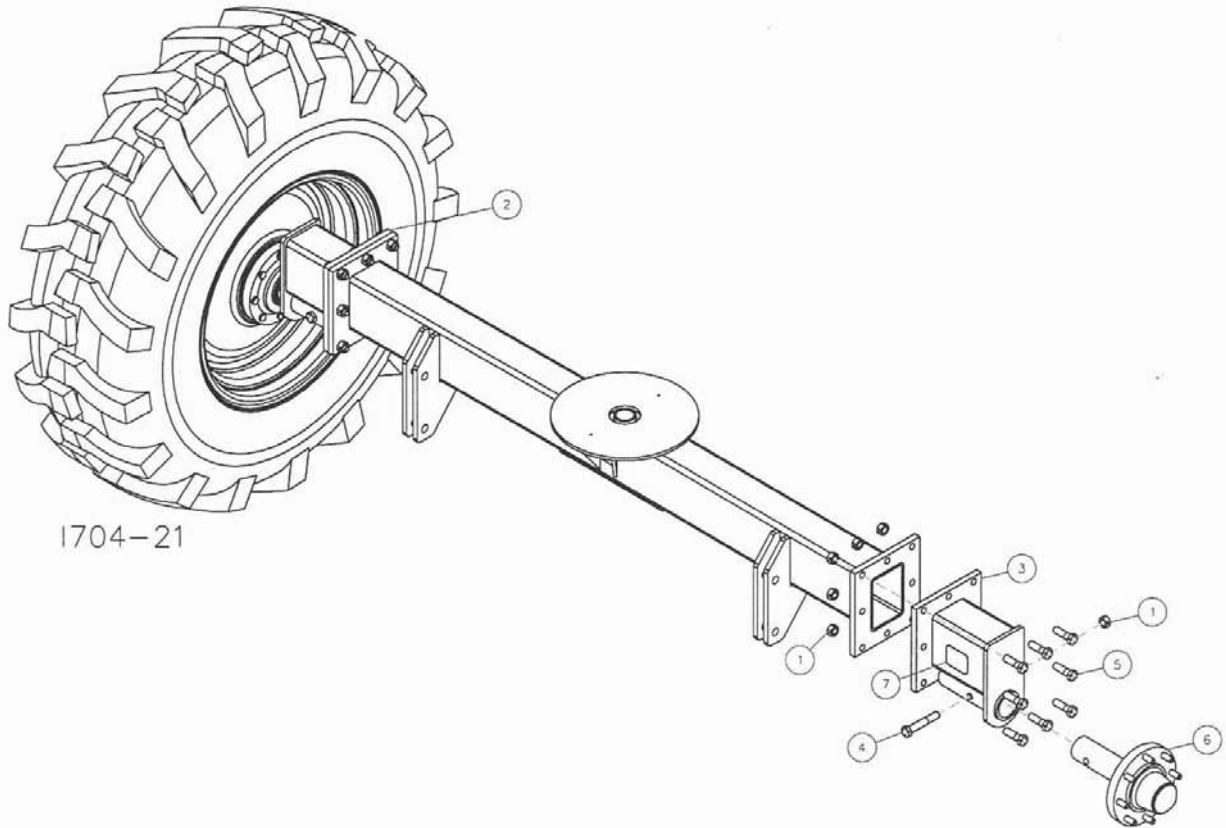

DET	QTY	PART NO.	DESCRIPTION
1	36	2520-515	3/4-10 LOCK HEX NUT ZP
2	2	2000-283	120" AXLE STUB, RH
3	2	2000-282	120" AXLE STUB, LH
4	4	2502-406	3/4-10 X 4-1/2 HHCS GR. 5
5	32	2502-407	3/4-10 X 2-1/2 HHCS GR. 5 ZP
6	4	2000-166	HUB ASSEMBLY
7	1	2565-803	AMBER REFLECTOR

**NOTE:** THE LEFT FRONT STUB AXLE HAS THE AMBER REFLECTOR DECAL.

**8-07 TO 11-09**

# PARTS IDENTIFICATION

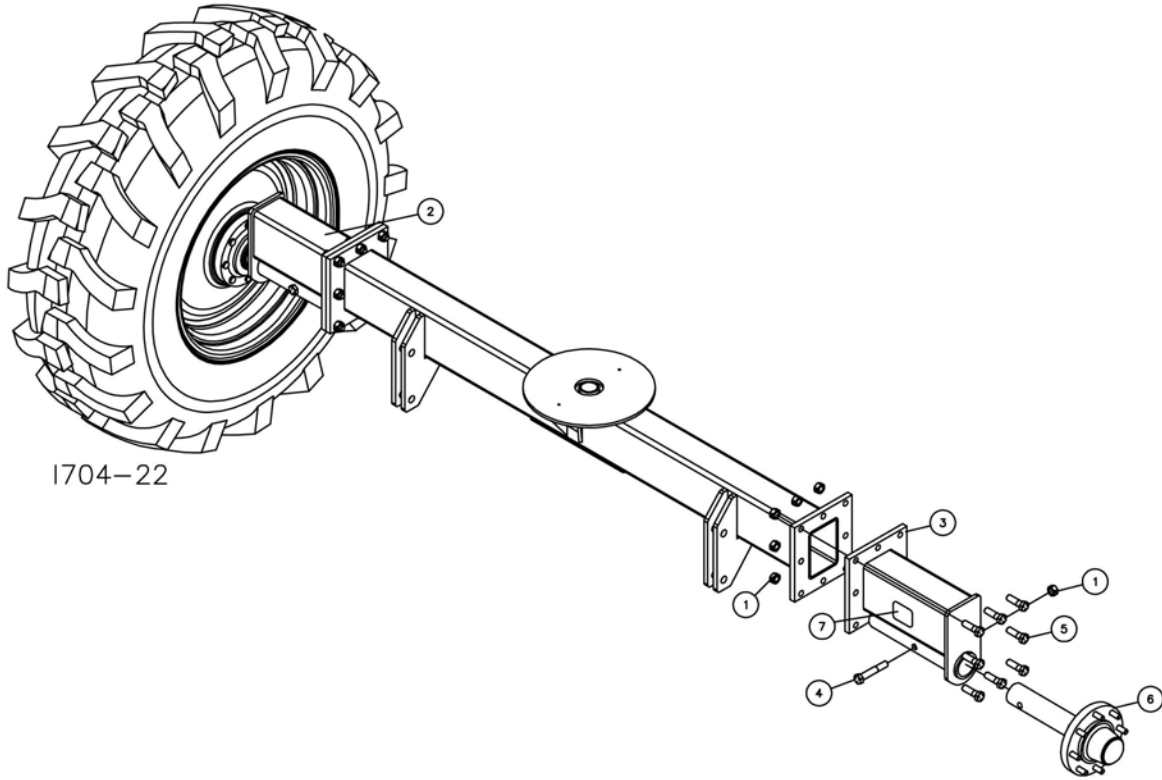

DET	QTY	PART NO.	DESCRIPTION
1	36	2520-515	3/4-10 LOCK HEX NUT ZP
2	2	2000-226	120"STUB AXLE WA, RH, 16" LONG
3	2	2000-281	120"STUB AXLE WA, LH, 16" LONG
4	4	2502-406	3/4-10 X 4-1/2 HHCS GR. 5
5	32	2502-407	3/4-10 X 2-1/2 HHCS GR. 5 ZP
6	4	2000-157	75-8 HUB ASSEMBLY
7	1	2565-803	AMBER REFLECTOR

12/09-PRESENT

# PARTS IDENTIFICATION

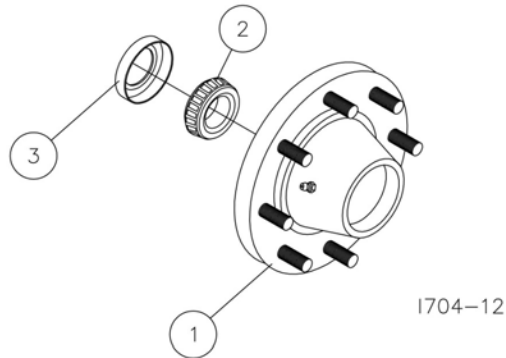

DET	QTY	PART NO.	DESCRIPTION
1	1	2000-322	60-8 HUB ASSEMBLY
	8	2000-384	5/8-18 X 2-1/2 STUD
	1		INNER CUP JLM506810
	1		OUTER CUP JLM501310
	1		GREASE FITTING #1720-B
2	1	2550-063	INNER BEARING 2-3/4"ID #906486
3	1	2550-026	GREASE SEAL

**NOTE: CAST HUB CANNOT BE ORDERED SEPARATE, ONLY ITEMS ASSEMBLED TO HUB CAN BE PURCHASED INDIVIDUALLY.**  
**PART NUMBERS LISTED UNDER 2000-322 ARE MANUFACTURERS' REPLACEMENT NUMBERS - NOT YETTER NUMBERS.**

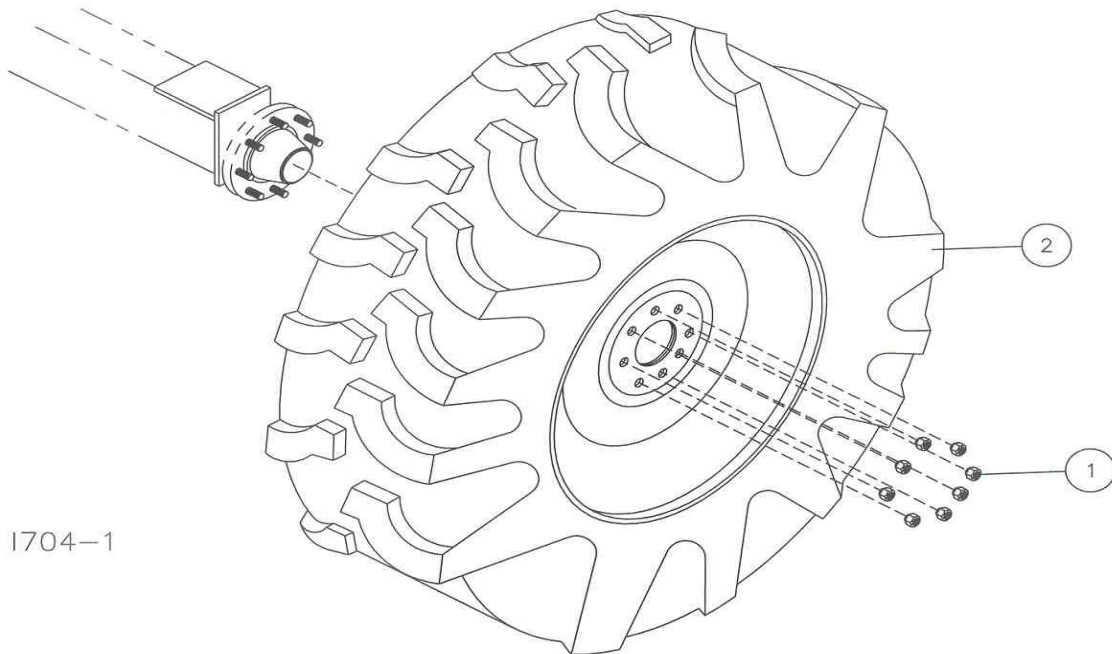

DET	QTY	PART NO.	DESCRIPTION
1	1	2520-370	WHEEL NUT #N913557
2	2	2000-102	18.4 X 26-10 TIRE/WHL-WHITE,RH
	2	2000-103	18.4 X 26-10 TIRE/WHL-BLACK,LH
	2	2000-105	18.4 X 26-10 TIRE/WHL-WHITE,LH
	2	2000-106	18.4 X 26-10 TIRE/WHL-BLACK,RH

# PARTS IDENTIFICATION

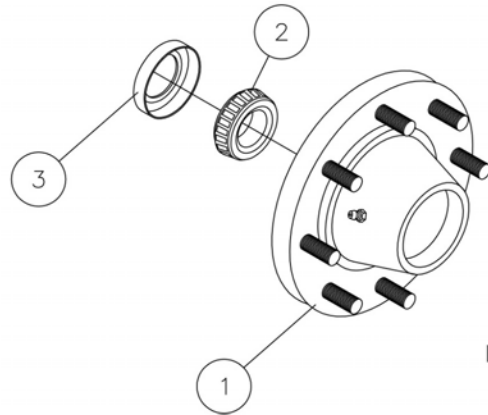

1704-24

DET	QTY	PART NO.	DESCRIPTION
1	1	2000-156	75-8 HUB SUB ASSEMBLY
	8	2000-384	5/8-18 X 2-1/2 STUD
	1		INNER CUP 382A/910358
	1		OUTER CUP LM501310
	1		GREASE FITTING #1720-B
2	1	2550-068	INNER BEARING #N910359
3	1	2550-067	GREASE SEAL 3"ID #N946486

12/09-PRESENT

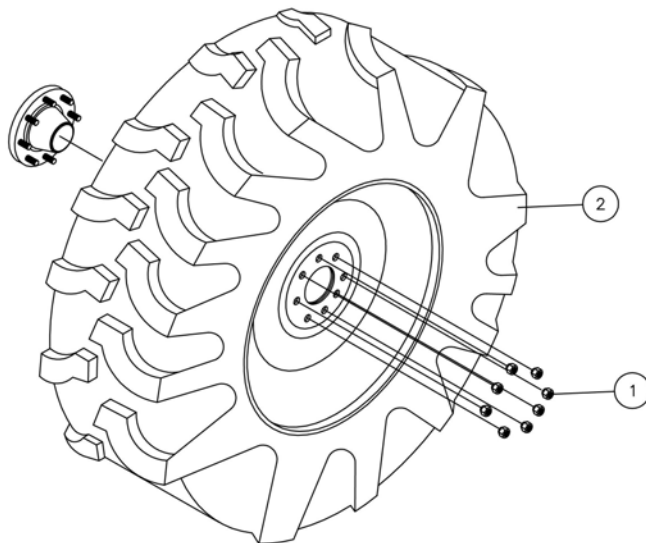

1704-23

DET	QTY	PART NO.	DESCRIPTION
1	1	2520-370	WHEEL NUT #N913557
2	2	2000-148	18.4X26-10TIRE/WHL-YEL,RH,1.38
	2	2000-149	18.4X26-10TIRE/WHL-YEL,LH,1.38
	2	2000-151	18.4X26-10TIRE/WHL-WHT,LH,1.38
	2	2000-152	18.4X26-10TIRE/WHL-WHT,RH,1.38
	2	2000-153	18.4X26-10TIRE/WHL-BLK,LH,1.38
	2	2000-154	18.4X26-10TIRE/WHL-BLK,RH,1.38

12/09-PRESENT



# PARTS IDENTIFICATION

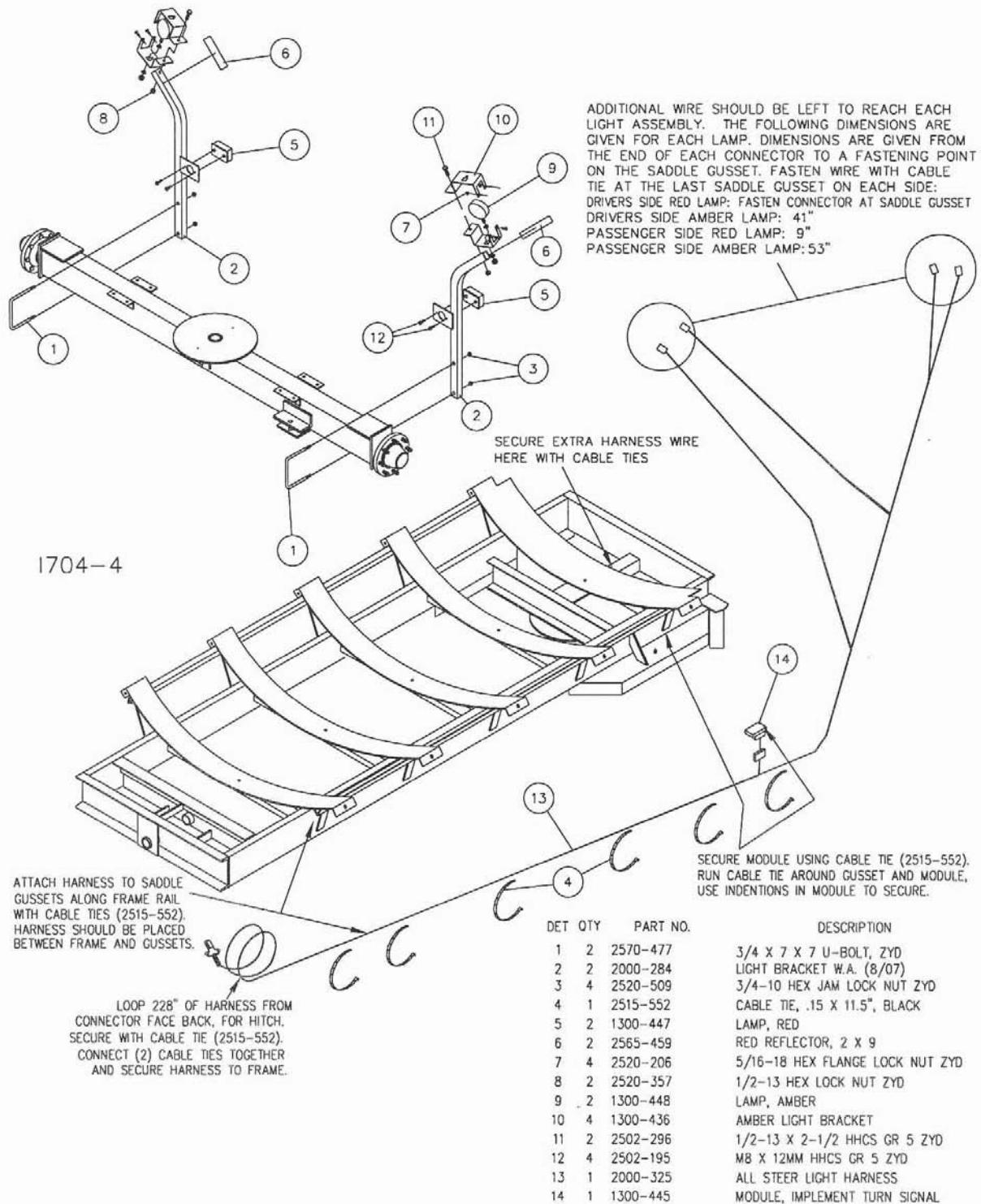

UPDATED 02/2009

## PARTS IDENTIFICATION

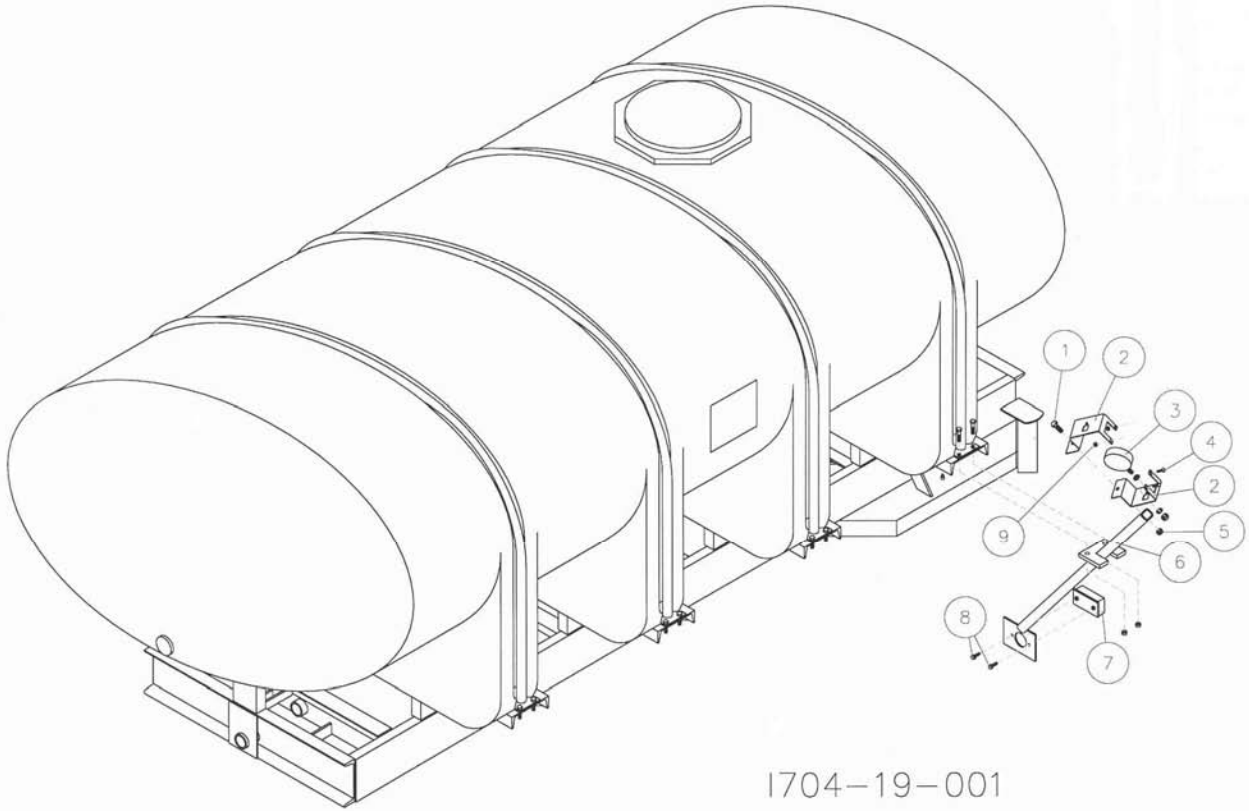

DET	QTY	PART NO.	DESCRIPTION
1	2	2502-296	1/2-13 X 2-1/2 HHCS GR 5 ZYD
2	4	1300-436	AMBER LIGHT BRACKET
3	2	1300-448	LAMP, AMBER
4	4	2505-205	5/16-18 X 3/4 CAR BOLT GR5
5	2	2520-357	1/2-13 LOCK HEX NUT ZP
6	1	2000-267	LIGHT BRKT WA, 2000 (1) TANK, LH
	1	2000-266	LIGHT BRKT WA, 2000 (1) TANK, RH
7	1	1300-447	LAMP, RED
8	4	2502-195	M8 X 12MM HHCS GR 5 ZYD
9	4	2520-206	5/16-18 FLANGE LOCK NUT

# PARTS IDENTIFICATION

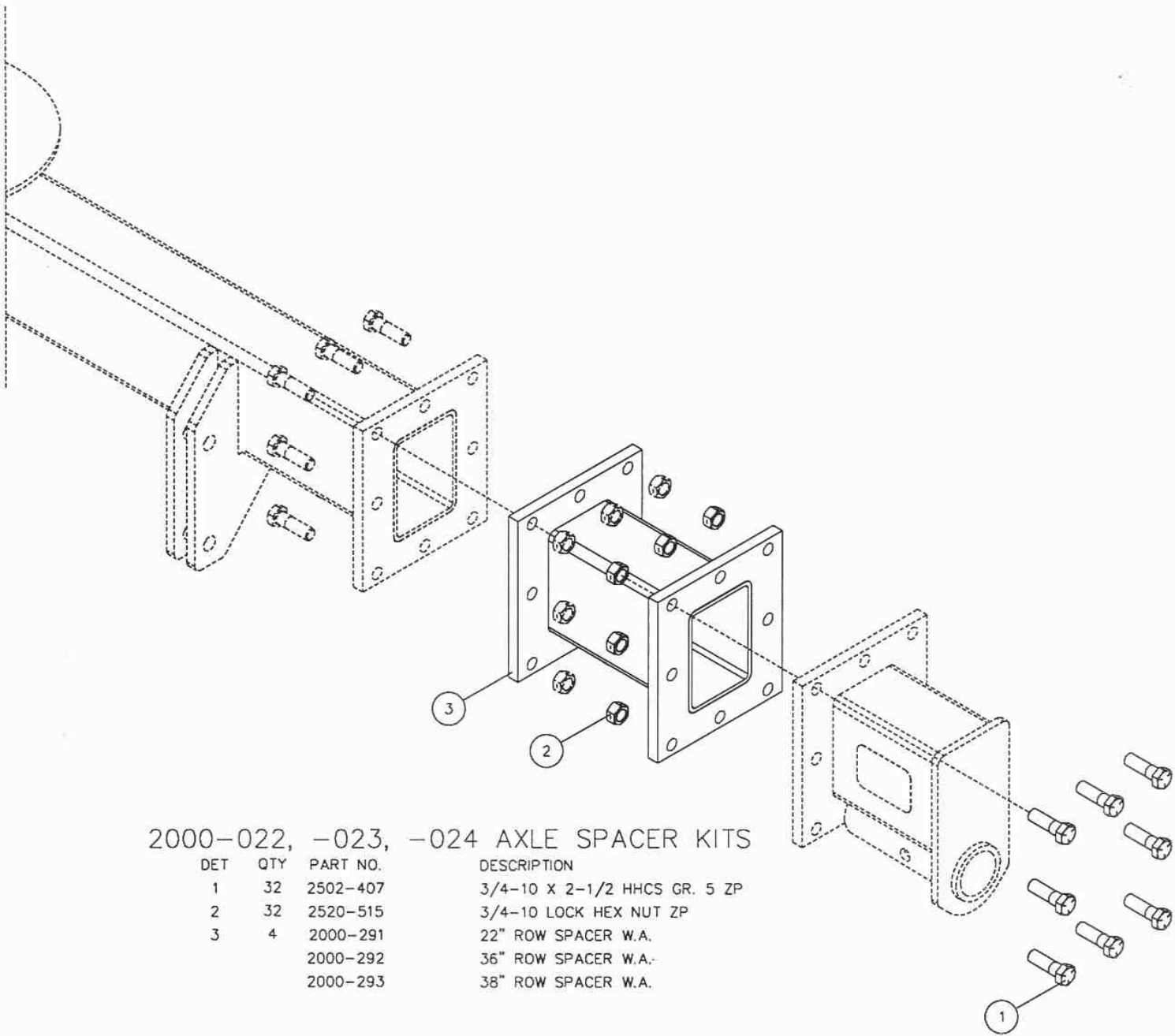

1765-1

# PARTS IDENTIFICATION

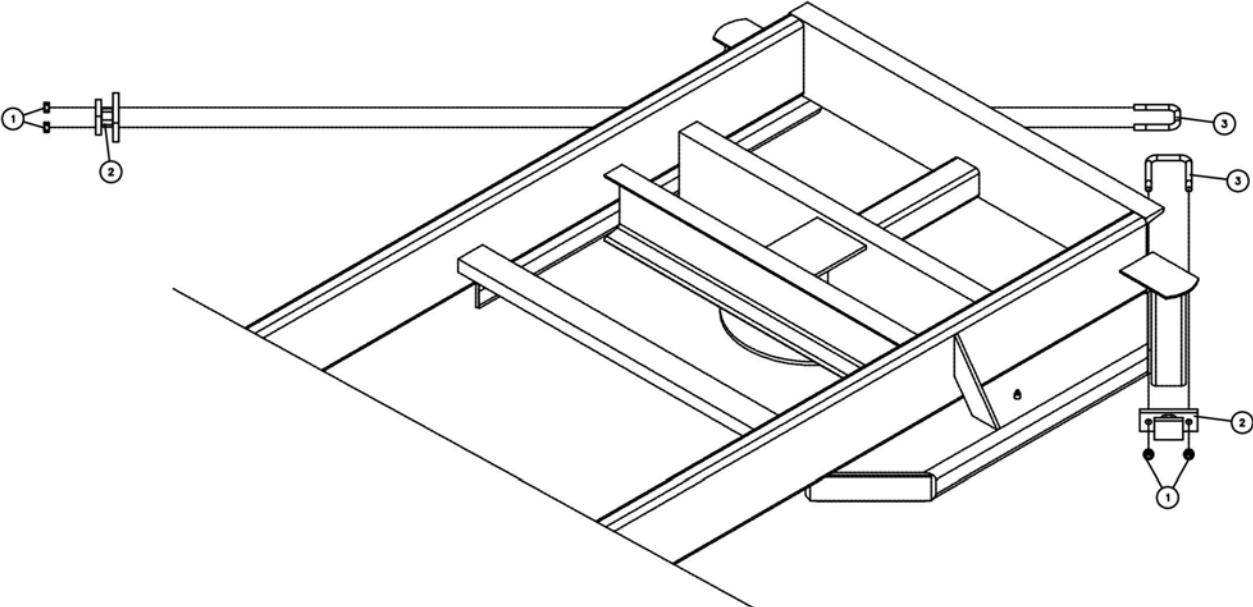

## AXLE STOPS

DET	QTY	PART NO.	DESCRIPTION
1	4	2520-357	1/2-13 LOCK HEX NUT ZP
2	2	2000-295	SHORT AXLE STOP W.A.
3	2	2570-777	.5 X 3 X 4.5 U-BOLT

1765-2

# PARTS IDENTIFICATION

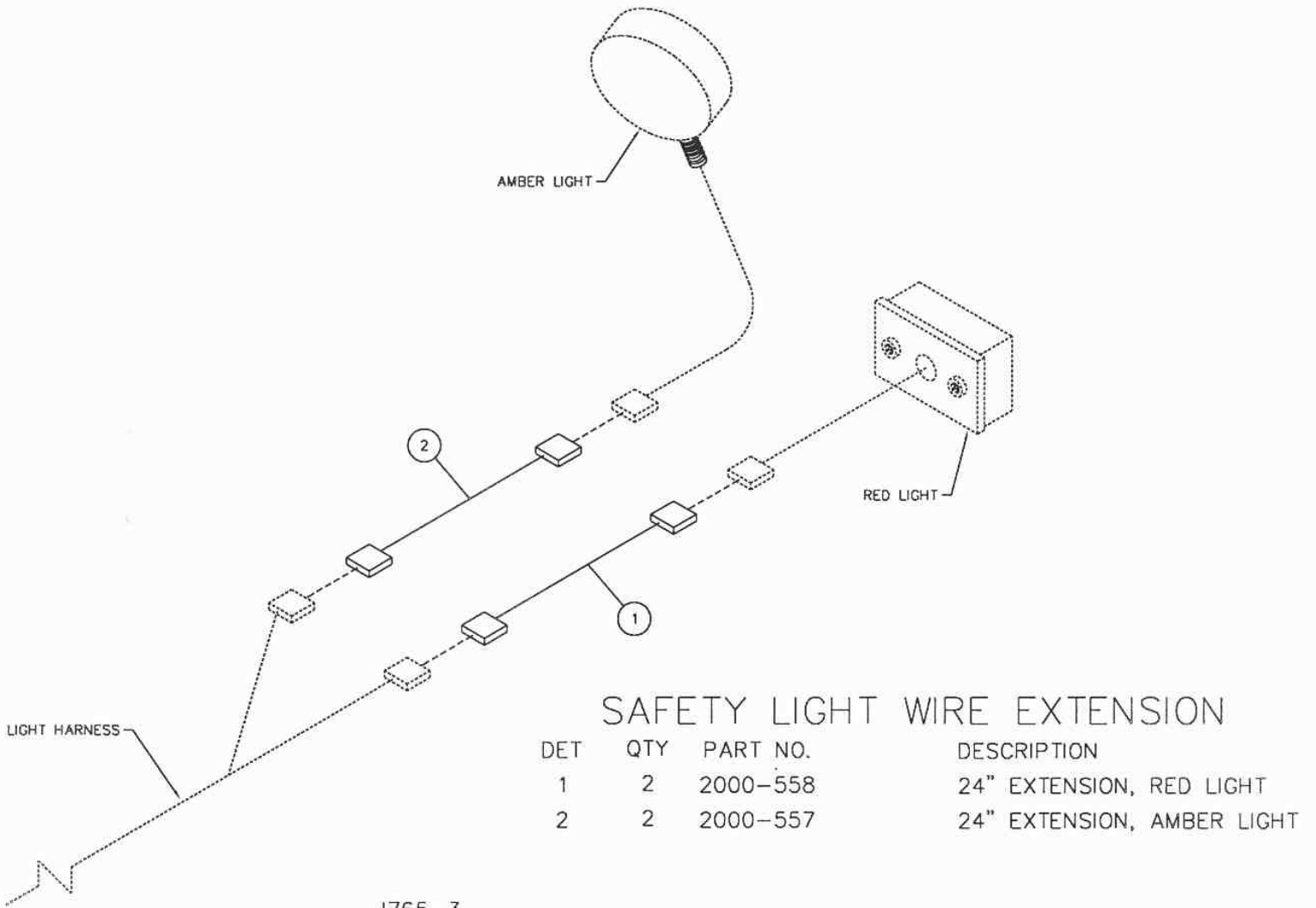

## SAFETY LIGHT WIRE EXTENSION

DET	QTY	PART NO.	DESCRIPTION
1	2	2000-558	24" EXTENSION, RED LIGHT
2	2	2000-557	24" EXTENSION, AMBER LIGHT

1765-3

## NOTES:

## NOTES:

# Our name Is getting known

Just a few years ago, Yetter products were sold primarily to the Midwest only. Then we embarked on a program of expansion and moved into the East, the South, the West and now north into Canada. We're even getting orders from as far away as Australia and Africa.

So, when you buy Yetter products . . .you're buying a name that's recognized. A name that's known and respected. A name that's become a part of American agriculture and has become synonymous with quality and satisfaction in the field of conservation tillage.

Thank you.

**YETTER MANUFACTURING CO.**

Colchester, IL 62326-0358 • 309/776-4111

Toll Free 800/447-5777

Fax 309/776-3222

Website: [WWW.YETTERCO.COM](http://WWW.YETTERCO.COM)

E-MAIL: [INFO@YETTERCO.COM](mailto:INFO@YETTERCO.COM)