

ITEM NO.	PART NUMBER	DESCRIPTION	QTY.
1	S150LP BODY	150W SPEAKER	1
2	S150LP GASKET	RUBBER GASKET	1
3	S150LP CONE	SPEAKER CONE	1
4	FASTSM6X20CSK	M6 X 20 COUNTERSUNK SCREW	10

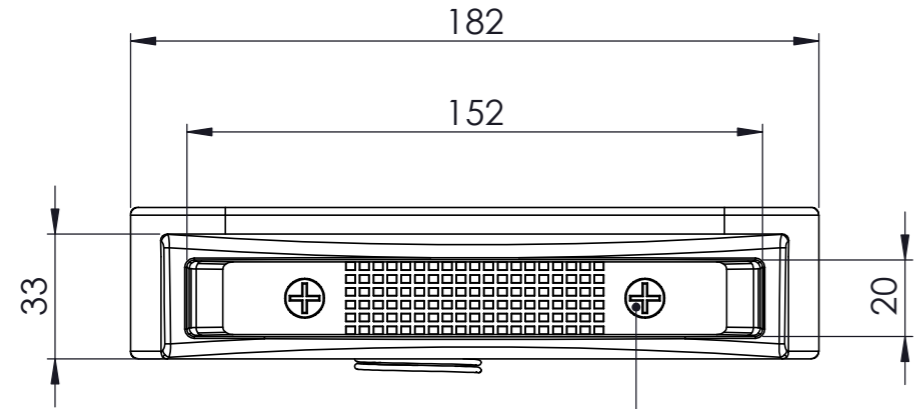

SPEAKER CONNECTION 1 SPEAKER CONNECTION 2



NOTE: CABLE COLOURS MAY CHANGE WITHOUT NOTIFICATION

360mm CABLE

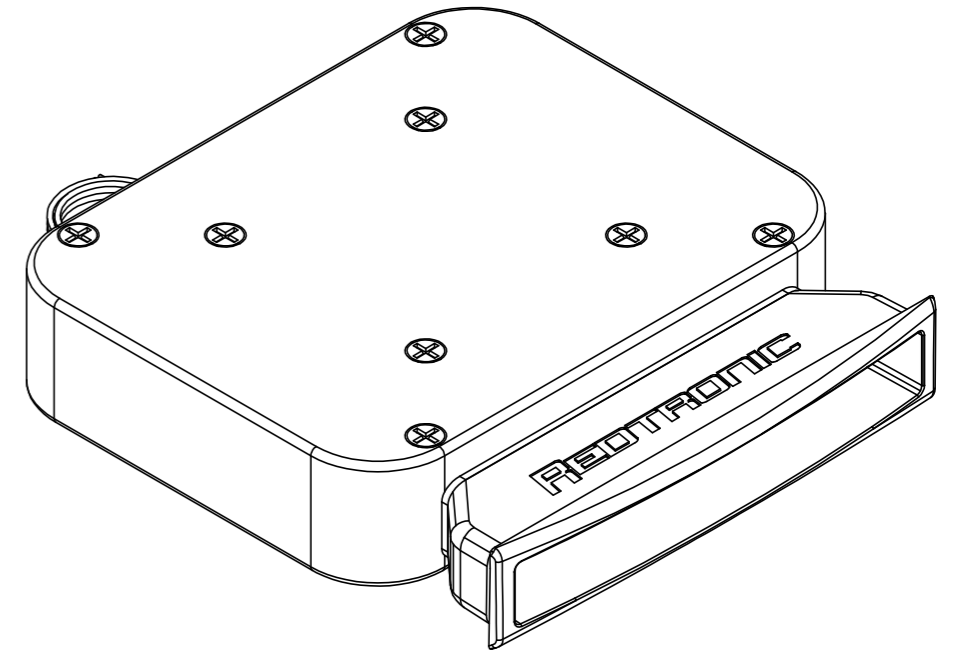
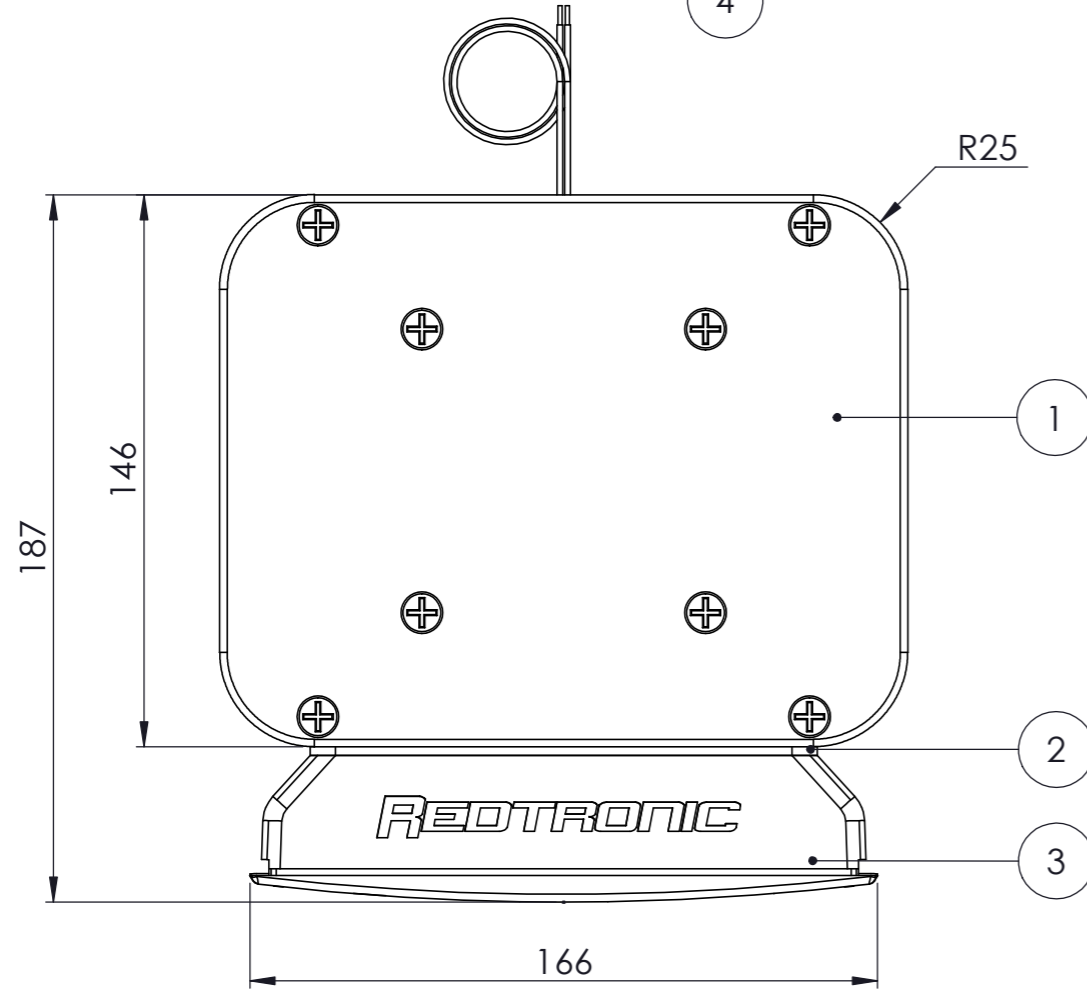
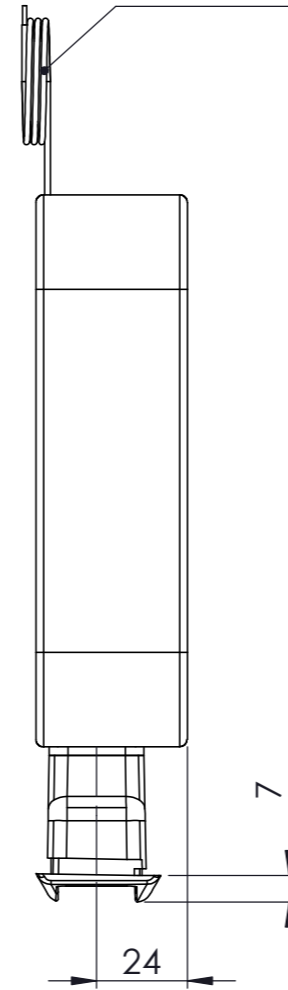

THIS DRAWING IS CONFIDENTIAL AND IS THE EXCLUSIVE PROPERTY OF REDTRONIC LTD.
NO UNAUTHORISED USE, COPY OR DISCLOSURE OF THE DRAWING IS TO BE MADE AND IT IS TO BE RETURNED WHENEVER REQUIRED.

PROJECTION
IF IN DOUBT ASK
A3

SCALE 1:2
DRAWNBY WJO
DATE 21/05/2021
WEIGHT 8.19 KG

UNLESS STATED
DIMENSIONS MM
TOL. LINEAR ±0.3
TOL. DIAGONAL ±0.5
TOL. ANGULAR ±0.5

MATERIAL AS PARTS
FINISH RAL9005 BLACK GLOSS POWDERCOAT

REDTRONIC
MANUFACTURERS OF EMERGENCY EQUIPMENT

DESCRIPTION
LOW PROFILE FLAT SPEAKER [150W / 110HM]

SHEET. 1 OF 1 | DWG NO S150LP-150W/110HM | REV A