

16 OFF HIGH POWER LED'S
AVAILABLE IN AMBER OR BLUE

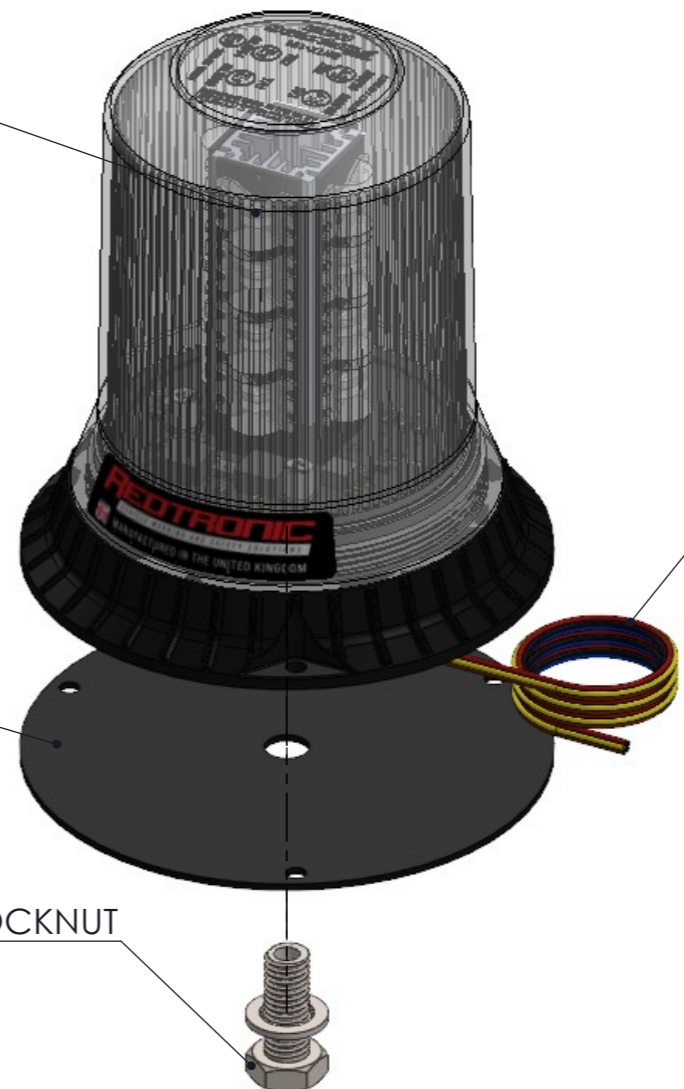

550mm LONG CABLE LOOM

PROTECTIVE FOAM PAD

CENTRALLY LOCATED M12 RETAINING BOLT
& SHAKEPROOF WASHER WITH INTERNAL LOCKNUT

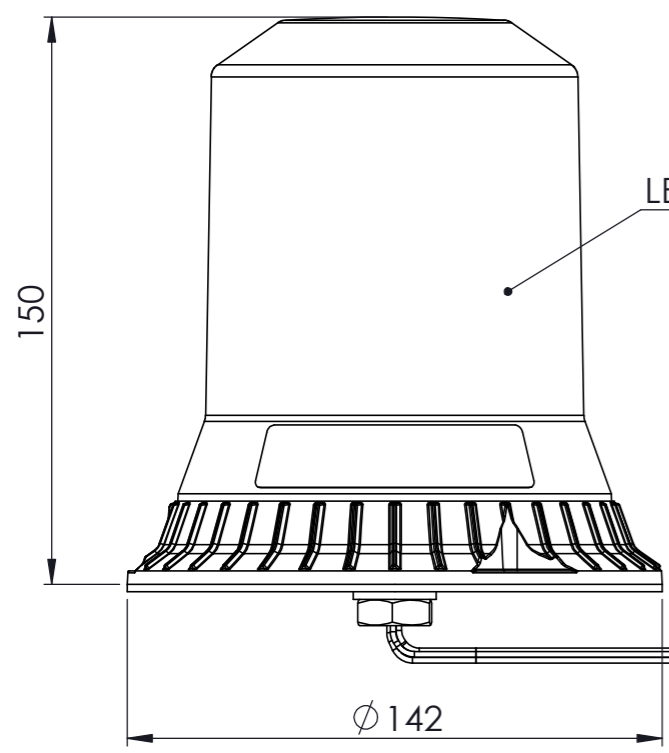

LENS AVAILABLE IN CLEAR, AMBER OR BLUE

THIS DRAWING IS CONFIDENTIAL
AND IS THE EXCLUSIVE
PROPERTY OF REDTRONIC LTD.

NO UNAUTHORISED USE, COPY
OR DISCLOSURE OF THE
DRAWING IS TO BE MADE AND IT
IS TO BE RETURNED WHENEVER
REQUIRED.

PROJECTION
IF IN DOUBT ASK
A3

SCALE 1:2
DrawnBy WJO
DATE 25/06/2021
WEIGHT 446.24 g

UNLESS STATED
DIMENSIONS MM
TOL. LINEAR ± 0.3
TOL. DIAGONAL ± 0.5
TOL. ANGULAR ± 0.5

MATERIAL SEE BILL OF MATERIALS
FINISH GLOSS



Description		
BEACON, TORNADO, B150,--, 1BOLT		
SHEET. 1 OF 2	DWG NO BTN1-150	REV A