

8 OFF HIGH POWER LED'S
AVAILABLE IN AMBER OR BLUE

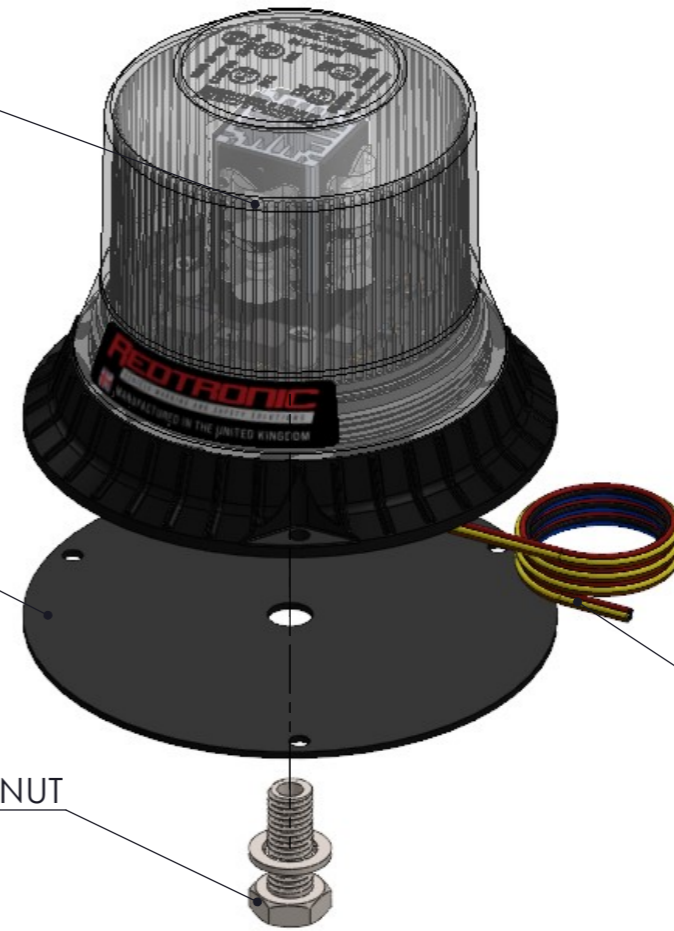

PROTECTIVE FOAM PAD

550mm LONG CABLE LOOM

CENTRALLY LOCATED M12 RETAINING BOLT
& SHAKEPROOF WASHER WITH INTERNAL LOCKNUT

LENS AVAILABLE IN CLEAR, AMBER OR BLUE

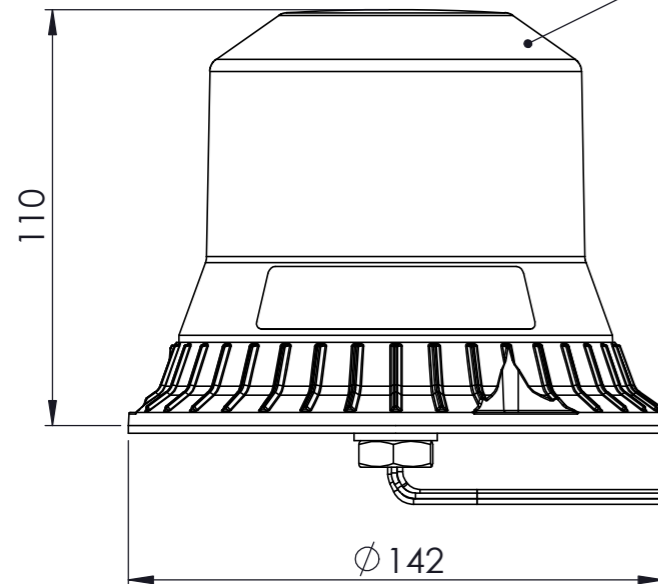

THIS DRAWING IS CONFIDENTIAL
AND IS THE EXCLUSIVE
PROPERTY OF REDTRONIC LTD.

NO UNAUTHORISED USE, COPY
OR DISCLOSURE OF THE
DRAWING IS TO BE MADE AND IT
IS TO BE RETURNED WHENEVER
REQUIRED.

PROJECTION



IF IN DOUBT ASK

A3

SCALE 1:2

DrawnBy WJO

DATE 25/06/2021

WEIGHT 348.47 g

UNLESS STATED

DIMENSIONS MM

TOL. LINEAR ± 0.3

TOL. DIAGONAL ± 0.5

TOL. ANGULAR ± 0.5

MATERIAL

SEE BILL OF MATERIALS

FINISH

GLOSS

REDTRONIC
VEHICLE WARNING AND SAFETY SOLUTIONS

Description

BEACON, TORNADO, B110,--, 1BOLT

SHEET. 1 OF 2

DWG NO BTN1-110

REV A