

WK2 Sump Protection Plate

Install Instructions

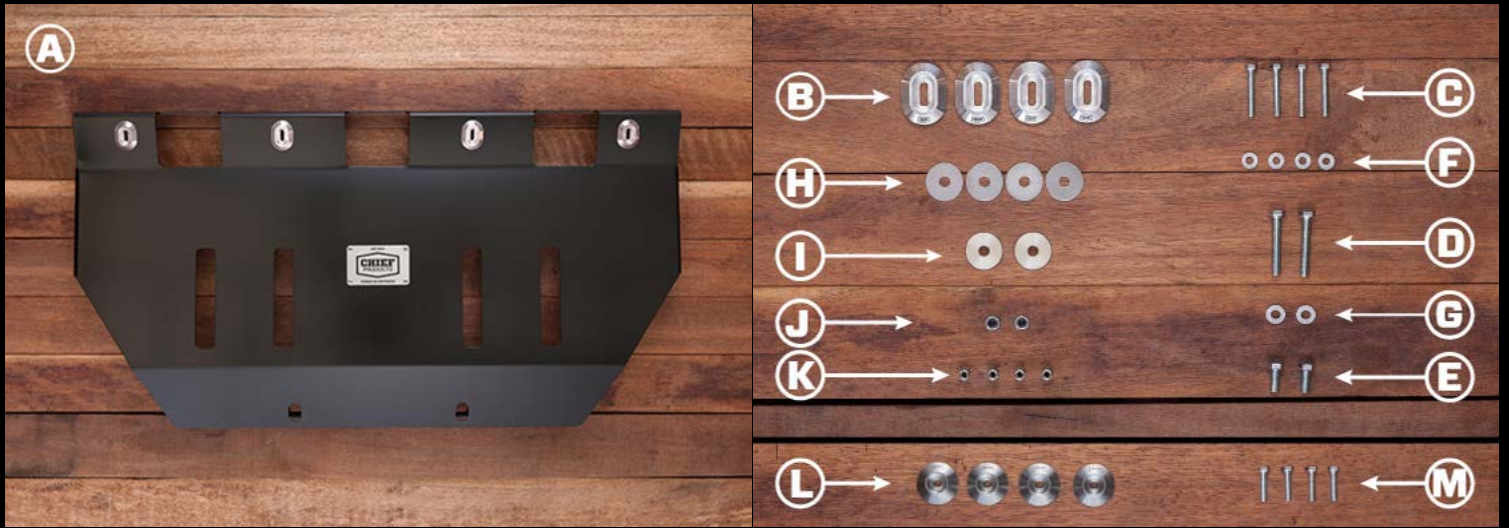

| REF | QTY | DESCRIPTION | REF | QTY | DESCRIPTION |
|-----|-----|---|----------------------------|-----|--|
| A | 1 | Sump Protection Plate | - | 1 | 4g Anti-Seize Pouch |
| B | 4 | M6 Bolt Head Protectors - Slotted (AL 5083) | - | 1 | Chief Products Shop Rag |
| C | 4 | M6 x 40mm 10.9 Bolts (Zinc) | RECOMMENDED INSTALL | | |
| D | 2 | M8 x 50mm 10.9 Bolts (Zinc) | K | 4 | M6 Nutserts (Stainless Steel) |
| E | 2 | M8 x 20mm 4.6 Bolts (Zinc) | ACCESS PANEL | | |
| F | 4 | M6 Wedge-Lock Extended Washers (Zinc Flake) | - | 1 | Access Panel |
| G | 2 | M8 Wedge-Lock Extended Washers (Zinc Flake) | L | 4 | M6 Bolt Head Protectors - Standard (AL 5083) |
| H | 4 | M8 x 32mm Flat Washer (Zinc) | M | 4 | M6 x 25mm 8.8 Bolts (Black Zinc) |
| I | 2 | M8 3mm Bushings | | | |
| J | 2 | M8 Nyloc Nuts (Zinc) | | | |

| REQUIRED TOOLS | |
|----------------|-------------------------|
| 10mm Socket | Ratchet |
| 13mm Socket | Ratchet Extension |
| 13mm Wrench | OPTIONAL - Nutsert Tool |

| NOTES |
|--|
| <ul style="list-style-type: none"> Do not over-tighten fasteners. Photos are representative only. They may show prototype parts and be taken from multiple vehicles. |

IMPORTANT

- PROPER INSTALLATION IS ESSENTIAL TO THE PERFORMANCE OF THIS PRODUCT.
- ONLY INSTALL THIS PRODUCT ON A 2011-2018 JEEP GRAND CHEROKEE.
- ONLY USE THE PROVIDED HARDWARE FOR INSTALLATION.
- DO NOT MODIFY THE STRUCTURE OF THIS PRODUCT IN ANY WAY.
- CHECK PRODUCT REGULARLY FOR DAMAGE. REPLACE IMMEDIATELY AT FIRST SIGN OF DAMAGE.
- CHECK FASTENER TIGHTNESS REGULARLY AND TIGHTEN IF REQUIRED.

1

Remove Lower Fascia.

1. Remove the lower fascia and set aside. Refer to the Owners Manual for basic instructions.

NOTE
This can be a tricky process. If you need help, we provide a 'How To' article on our website, (www.chiefproducts.com.au/blogs/how-to/11555201-wk2-lower-front-fascia-removal-installation). You can also download a PDF of the process here, (www.chiefproducts.com.au/installation/wk2-lower-front-fascia-removal-and-installation.pdf).



WK2 Sump Protection Plate

Install Instructions

2

Detach Inner Wheel Well Liners.

1. Remove (1) M6 Bolt on each side, (drivers & passengers). You may need to hold the clip on the backside so it doesn't turn.

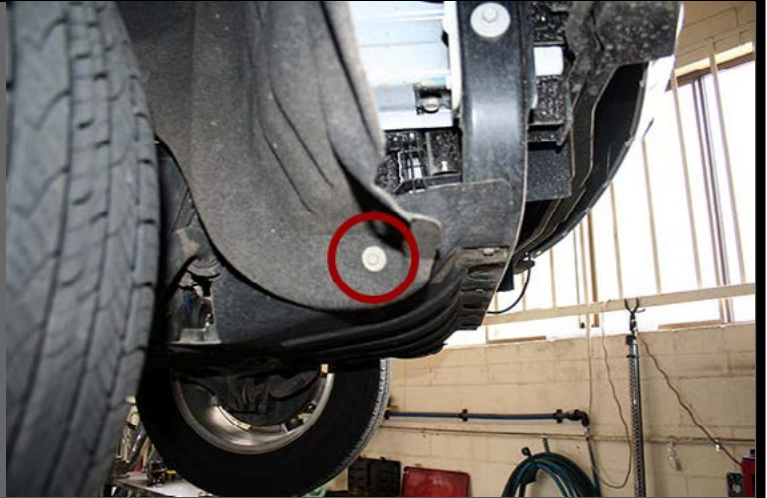

3

Unbolt stock plastic 'Belly Pan'.

1. Remove (3) M6 Bolts in front.
2. Remove (2) M8 Bolts in rear.
3. Some WK2s also require the removal of a push-in fastener, (square). This can be removed with a flat head screwdriver.

The stock 'Belly Pan' can now be removed.

NOTE

If you have Mopar Skid Plate Part #68199890AB remove this now (See inset image).

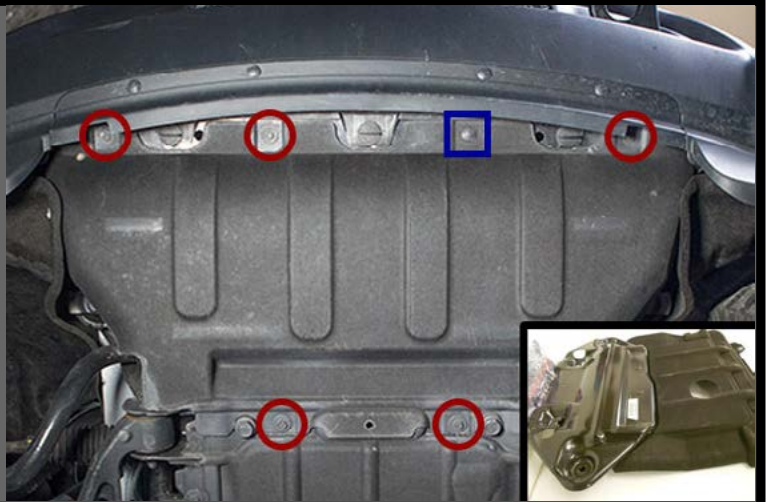

4

USA Models

Unbolt plastic 'Corner Guards'.

1. Remove the bolt holding the plastic Corner Guard to the sub-frame. Do this on both sides.
2. Leave Corner Guards hanging loose. Retain bolts.



RECOMMENDED INSTALL

The (3) M6 threads in the frame can be easily stripped if the M6 x 40mm Bolts [C] are over-tightened. Accidental over-tightening can happen during install or by a mechanic performing a service. For that reason, we've provided (4) M6 Nutserts [O] for anyone that wishes to upgrade the mounting points in the frame. The nutserts increase the thread length from 2-3mm to 9-10mm, greatly increasing the strength of the threads. It also provides an opportunity to add a 4th mounting point. Detailed instructions are available here, (www.chiefproducts.com.au/installation/wk2-m6-nutserts.pdf). Please note, installation requires a nutsert tool.

WK2 Sump Protection Plate

Install Instructions

5

Prepare for installation.

1. Prepare M6 Assembly - Slide (1) M6 Wedge-Lock Extended Washer [F] and (1) M6 Bolt Head Protector [B] onto (1) M6 x 40mm Bolt [C]. Do this for (3) M6 Bolt Head Protectors.

NOTE

We've provided (4) M6 Assemblies. You'll only need the 4th assembly if you perform the recommended nutsert install (above).



RECOMMENDED STEP

Place beer in freezer for later.

6

Bolt Sump Protection Plate to vehicle.

1. Hold Sump Protection Plate [A] against front cross member.
2. Install (3) M6 Assemblies into front bolt holes. Do not tighten fully. If you've installed a 4th nutsert into the sub-frame, install all (4) M6 Assemblies.

NOTE

If you're performing the install on the ground, it can be helpful to use a jack or upside down bucket to hold the back of the plate loosely in place, while installing the front bolts.



7

Bolt Sump Protection Plate to vehicle.

1. Slide (1) M8 Wedge-Lock Extended Washer [G] onto (1) M8 x 50mm Bolt [D].
2. Slide the bolt & washer combo up through the Sump Protection Plate [A].
3. Place (1) M8 3mm Bushing [I] on top.
4. Hold Sump Protection Plate [A] tight against the vehicle and thread the M8 x 50mm Bolt [D] into the frame. Tighten until finger tight.
5. Do this for both rear mounting points.

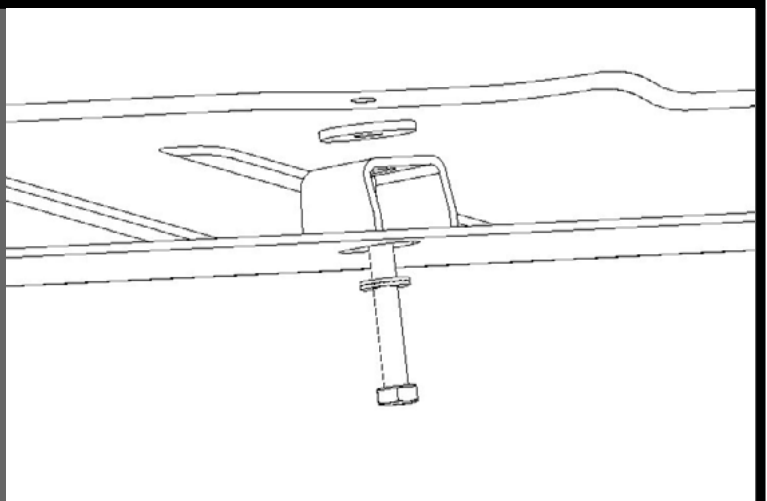

WK2 Sump Protection Plate

Install Instructions

NOTES

- It can help to use a 13mm Socket and Ratchet Extension to install the M8 x 50mm Bolts up through the holes in the Sump Protection Plate.
- **If you have the Mopar 'Front Axle Skid Plate'**, the WK2 Sump Protection Plate bolts on top. This configuration provides a smooth undercarriage as well as extra air flow and drainage.

8

Bolt Sump Protection Plate to vehicle.

1. Tighten all M6 Assemblies. Ensure M6 Bolt Head Protectors [B] key into Sump Protection Plate [A] and sit flush. Be careful not to over-tighten the M6 Bolts.
2. Tighten rear bolts.

NOTE

Recommended M8 Bolt Torque = 33Nm (Dry) or 28Nm (Anti-Seize)
 Recommended M6 Bolt Torque = 13Nm (Dry) or 11Nm (Anti-Seize)
 Recommended M6 Bolt Torque (with nutsert upgrade) = 19Nm (Dry) or 16Nm (Anti-Seize)



9

USA Models

Reattach plastic 'Corner Guards'.

1. Slide stock bolt through plastic Corner Guard, through hole in Sump Protection Plate [A] and into sub-frame.
2. Tighten.
3. Do this for both sides.



10

Attach Inner Wheel Well Liners.

1. Tuck wheel well liner behind side tab on Sump Protection Plate [A]. Place (1) M8 x 32mm Washer [H] onto (1) M8 x 20mm Bolt [E]. Insert bolt & washer combo through slot on Sump Protection Plate [A] and hole in wheel well liner. Slide (1) M8 x 32mm Washer [H] over bolt shaft on inside of wheel well liner and attach (1) M8 Nyloc Nut [J]. Slide as far forward as possible and tighten.
2. Do this for both sides, (drivers & passengers).



WK2 Sump Protection Plate

Install Instructions

11

Re-install Lower Fascia.

1. Re-install the lower fascia. Refer to the Owners Manual for basic instructions.

NOTE

This can be a tricky process. If you need help, we provide a 'How To' article on our website, (www.chiefproducts.com.au/blogs/how-to/11555201-wk2-lower-front-fascia-removal-installation). You can also download a PDF of the process here, (www.chiefproducts.com.au/installation/wk2-lower-front-fascia-removal-and-installation.pdf).



WK2 Sump Protection Plate is now fully installed.

REMINDER

Don't forget about the beer in the freezer!

ACCESS PANEL

[START]

1 Access Panel

Remove/Install Access Panel.

1. Remove/install (4) M6 x 25mm Bolts [**N**] and (4) M6 Bolt Head Protectors [**M**].

NOTE

Tilting the Access Panel sideways allows you to easily slip it through the hole in the WK2 Sump Protection Plate.
Recommended M6 Bolt Torque = 19Nm (Dry) or 16Nm (Anti-Seize)



ACCESS PANEL

[END]



WK2 Sump Protection Plate

Install Instructions

MAINTENANCE

FASTENERS

- Check fastener tightness regularly and tighten if required. We recommend checking fasteners after every large off-road trip.

CORROSION PROTECTION

- After an off-road trip; rinse all mud, sand or debris off the product.
- After driving in salt water; rinse product thoroughly with fresh water.

EXTRA CARE

- If you're planning to drive in a salty environment; spray fasteners with WD40 or an equivalent.
- If you're planning to drive in a salty environment; spray product with Lanolin or an equivalent.
- Spray deep scratches (before they rust) with touch up paint to help inhibit corrosion.

SUPPORT

Find answers online.

www.chiefproducts.com.au/pages/support

Having troubles? Make sure you've downloaded the most recent version of these instructions from our website. We occasionally make updates.

www.chiefproducts.com.au/installation/wk2-sump-protection-plate.pdf

If you need additional help, send us an email.

support@chiefproducts.com.au

SHARE

Looking to share epic photos of your WK2?

Send us your photos - Unboxing, Fully Installed, Painted-In-Mud or out Adventuring in some beautiful location. If you share with us, we'll share with our followers.

UPLOAD

www.chiefproducts.com.au/share

EMAIL

connect@chiefproducts.com.au

HASHTAG

#ChiefProducts #GrandAdventure