

Drainage technology – floor drains

## Drainage technology – channels

Manhole & pipe leadthrough

Crash guards & edge protectors

Doors & windows

Hygiene & furnishing elements

Control cabinets

Exterior design elements

Special commissions

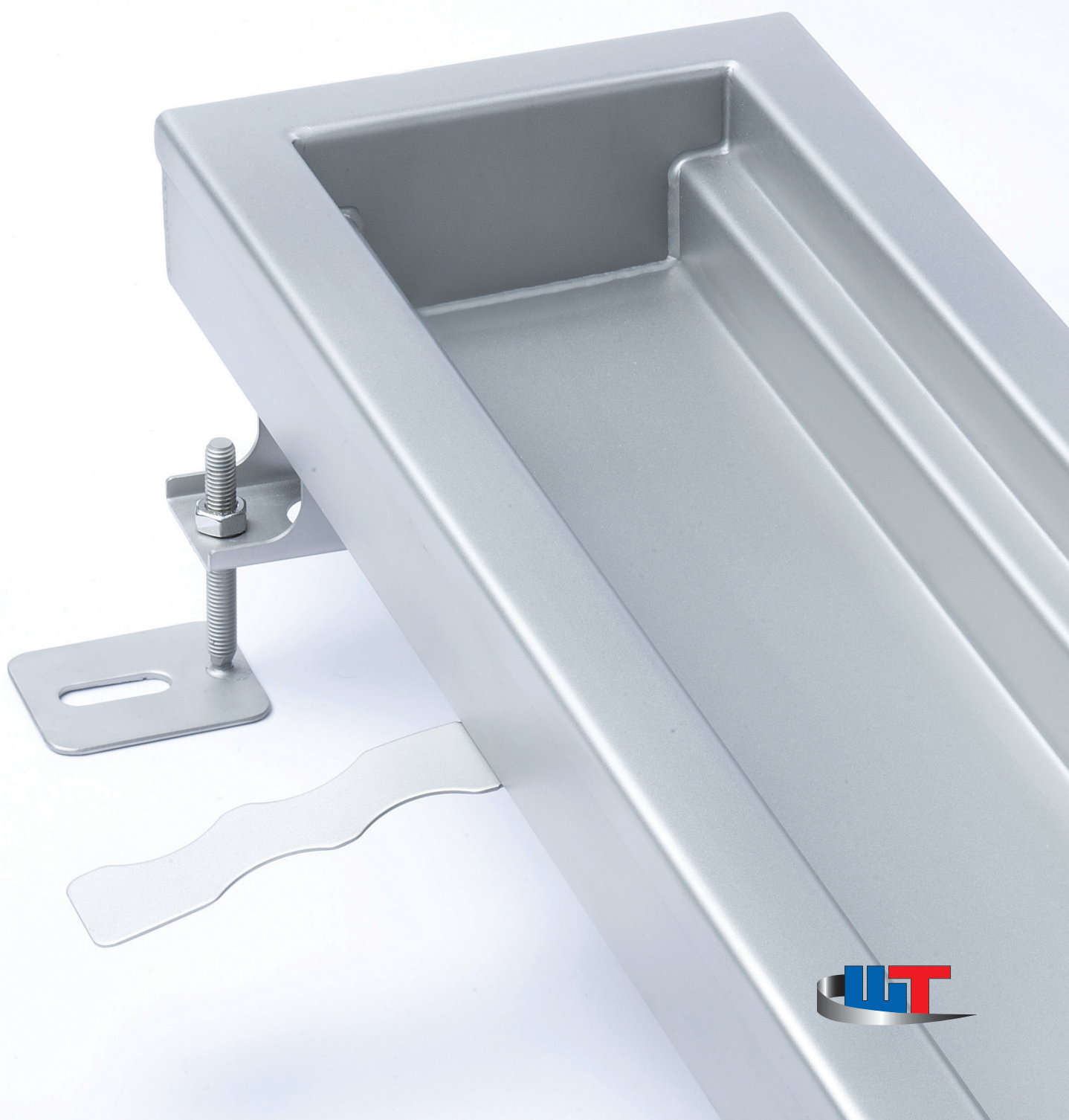

## Drainage channels

WIEDEMANN has been making stainless steel drainage channels for over 30 years.

We have used this experience to further develop our drainage channels, adapting them to meet the ever-increasing requirements. Our focus is, and always has been, on the hygienic needs of the food processing industry.

For example, we are able to realise great channel lengths for you, with and without flange

connections – tailored to your operational requirements with millimetre accuracy. To guarantee this quality we only install WIEDEMANN drainage channels using our own fitters. From the time-intensive co-ordination of the installation to fully fitted, ready-for-use channels – our fitters level, align, weld and secure your new stainless steel channels on site. This way you gain time while getting first class WIEDEMANN quality.

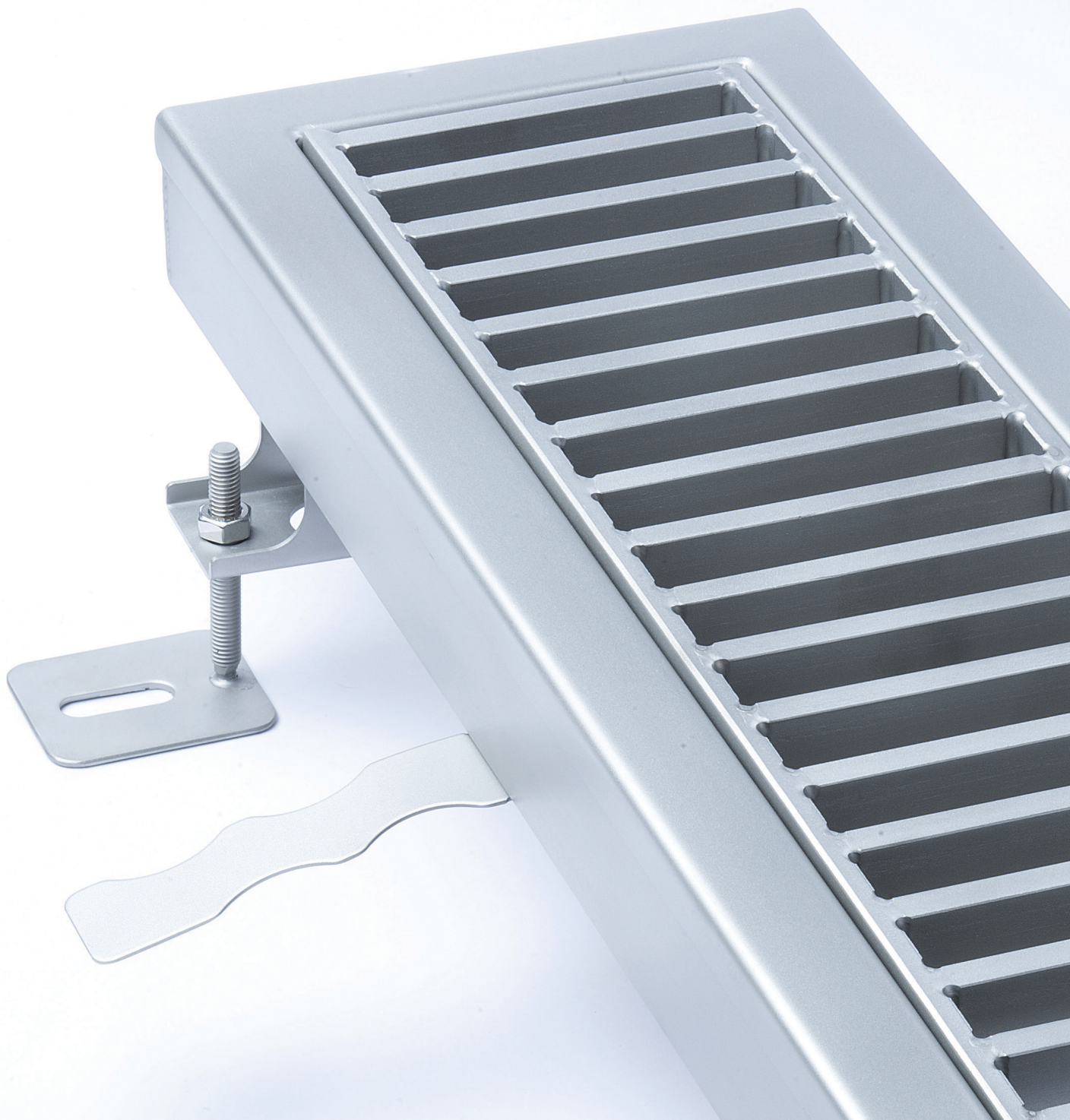

WIEDEMANN slot channels and channels can be used for a variety of purposes in the following areas:

- Beverage industry
- Meat industry
- Dairy industry
- Chemical and pharmaceutical industry
- Commerical kitchens

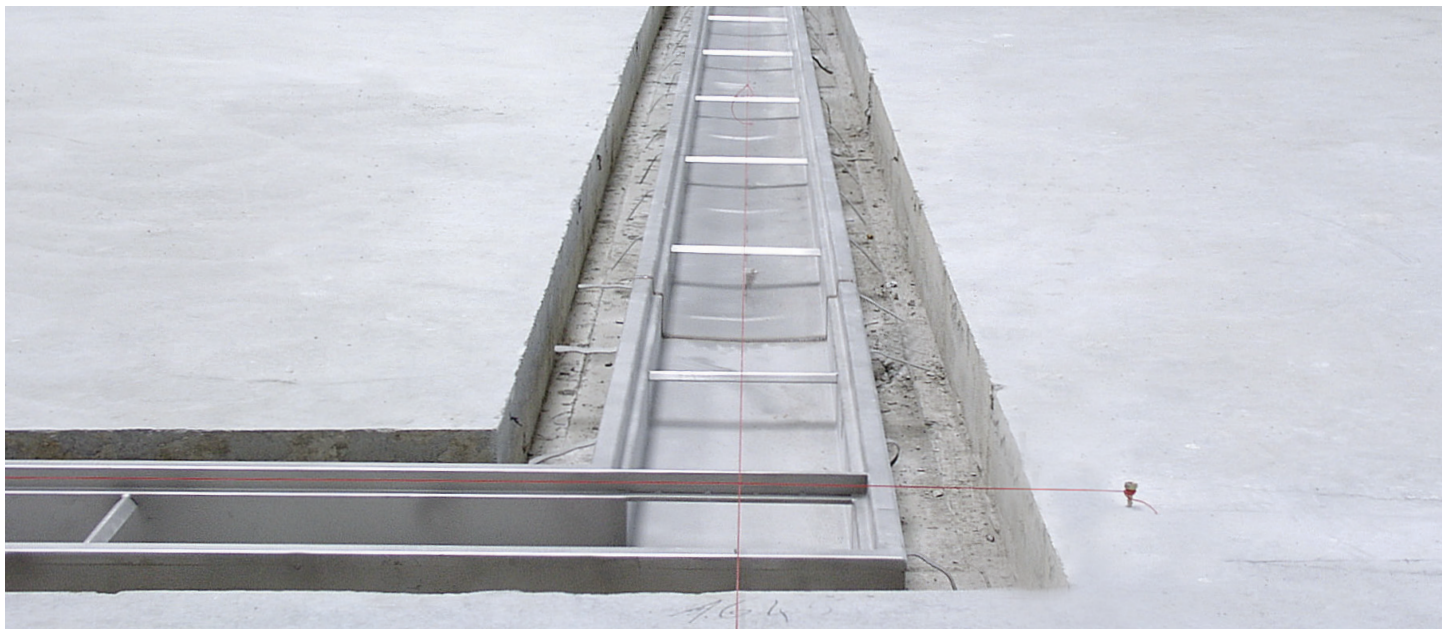
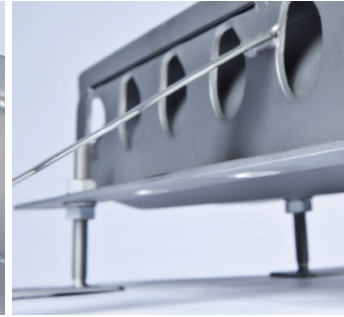
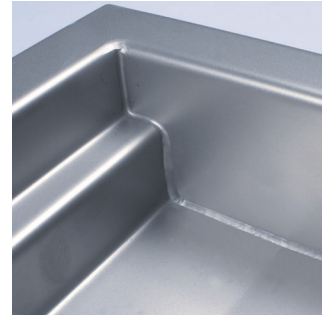

### **Slot channels for smaller volumes of wastewater**

Our channels are fully visible through their slots, which means they can be examined at any time to verify their cleanliness. This ensures that they can be kept in a fully hygienic state.

WIEDEMANN slot channels are also available without spacers to facilitate cleaning. WIEDEMANN channels are available in various load classes.

### **Channels for volumes of wastewater**

WIEDEMANN channels are available in various widths, coordinated for the volumes of water to be transported. They are also capable of acting as temporary stores for large amounts of water for short periods.

The most varied covers are available for all our channels.

Gratings, bar grates, and plate covers are available with various anti-slip and load bearing characteristics.





### Channels

■ IKR with welded/underwelded channel floor drain .....	6
■ IKR with plug-in channel floor drain .....	8
■ GKR with welded/underwelded channel floor drain .....	10
■ GKR with plug-in channel floor drain .....	12
■ VKR .....	14
■ KRS .....	16

### Slot channels

■ SRD .....	18
■ SRO .....	20
■ SRZ .....	22
■ SRD50 .....	24

### **NEW** "Sharp-edged" channels

■ SKR-I .....	28
■ SKR-G .....	29
■ SVKR .....	30
■ SSRD .....	31

### Channel drains

■ RSKE-MIT-S .....	32
■ RSKE-END-S .....	33
■ RSKE-MIT-W .....	34
■ RSKE-END-W .....	35
■ RSKH-MIT-S .....	36
■ RSKH-END-S .....	37
■ GKSE-MIT-S .....	38
■ GKSE-END-S .....	39

### Floor basin

■ BOWA .....	40
■ DDSB .....	42

### Floor connection

■ Adhesive flange .....	43
■ Attachment flange .....	43
■ Tile connection angle .....	43

### Special solutions

■ Special solutions .....	44
■ Channel shapes .....	45
■ Cover variants .....	46
■ Flap grate .....	47

### Installation instructions

■ Cavity dimensions and installation .....	48
■ Flange connections .....	49

### Manhole

■ SA-E-PTÄ .....	50
■ SA-RD-PTÄ .....	51
■ SA-E-BTF .....	52
■ SA-RD-BTF .....	53

### Pipe leadthrough

■ RDFN .....	54
■ RDFD .....	55

<b>Cleaning and care instructions for stainless steel .....</b>	<b>56</b>
---	-----------

## Industrial channel IKR

■ with welded/underwelded channel drain

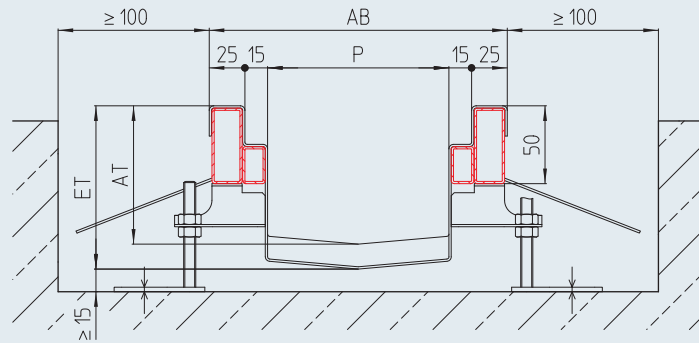
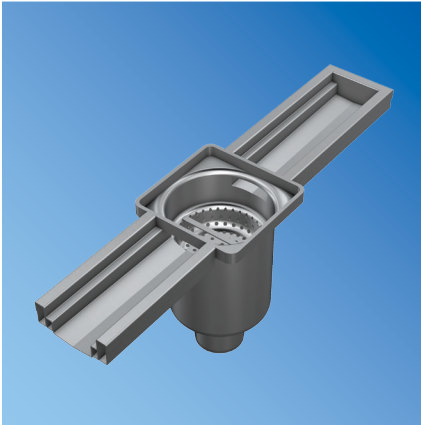

Channel model	P [mm]	AB [mm]	AT <sup>7)</sup>	Fall	ET [mm]
IKR-070-150	70	150	60	0.6%	
IKR-090-170	90	170	60	0.6%	
IKR-120-200	120	200	60	0.6%	
IKR-170-250	170	250	60	0.6%	
IKR-220-300	220	300	60	0.6%	
IKR-320-400	320	400	60	0.6%	
IKR-420-500	420	500	60	0.6%	

**Calculation ET:**  $AT + L1 \times 0,006$  [AT; ET; L1 in mm]

### Grade

■ 1.4301 (AISI 304) ■ 1.4571 (AISI 316 Ti)<sup>1)</sup>

### Cover variants

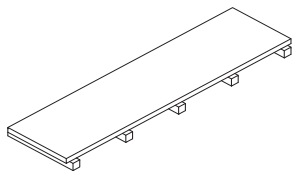

■ Plate cover M125

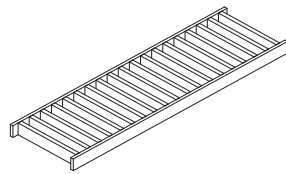

■ Bar grate cover M125

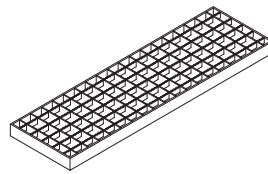

■ Grating L15

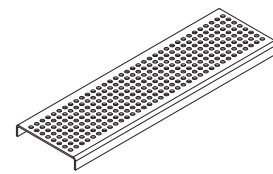

■ Plate cover; 3,0 mm K3

### Floor connection (optional)

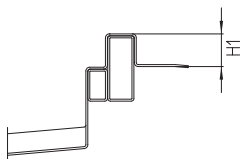

**AF** Attachment flange<sup>1)</sup>

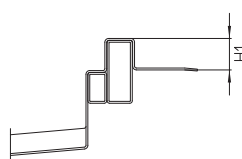

**HF** Bonding flange<sup>1)</sup>

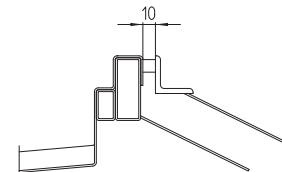

**FAWI** Tile connection angle

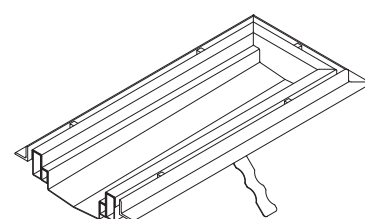
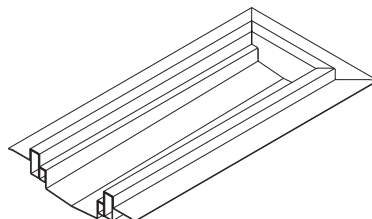
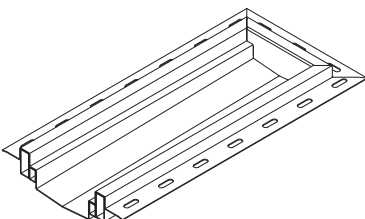

Channel drain <sup>6)</sup> – vertical – welded – single-part								Channel drain <sup>6)</sup> – horizontal – welded – single-part								
Model	DN	Ø d [mm]	∇ B [mm]	Ø D [mm]	H <sup>9)</sup> [mm]	to IKR-...	from IKR-...	Model	DN	Ø d [mm]	∇ B [mm]	Ø D [mm]	H <sup>9)</sup> [mm]	HRS <sup>9)</sup> [mm]	to IKR-...	from IKR-...
RBE DRS-070-E-S	70	75	180	153	280	70-150	-	RBE DRS-070-E-W	70	75	180	153	265	247	70-150	-
RBE DRS-100-E-S	100	110	246	218	300	120-200	-	RBE DRS-100-E-W	100	110	246	218	300	289	120-200	-
RBE DRS-150-E-S	150	160	310	283	355	170-250	-	RBE DRS-150-E-W	150	160	310	283	365	349	170-250	-

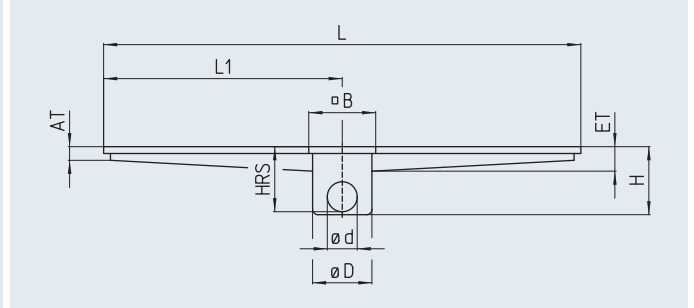
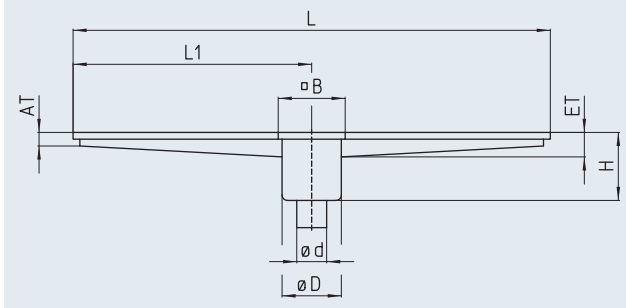

Channel drain <sup>6)</sup> – vertical – underwelded – single-part							Channel drain <sup>6)</sup> – horizontal – underwelded – single-part							
Model	DN	Ø d [mm]	Ø D [mm]	HU [mm]	to IKR-...	from IKR-...	Model	DN	Ø d [mm]	Ø D [mm]	HU [mm]	HRS [mm]	to IKR-...	from IKR-...
RBE DRS-070-S	70	75	153	161	-	170-250	RBE DRS-070-W	70	75	153	161	143	-	170-250
RBE DRS-100-S	100	110	218	195	-	220-300	RBE DRS-100-W	100	110	218	195	184	-	220-300
RBE DRS-150-S	150	160	283	235	-	320-400	RBE DRS-150-W	150	160	283	276	260	-	320-400

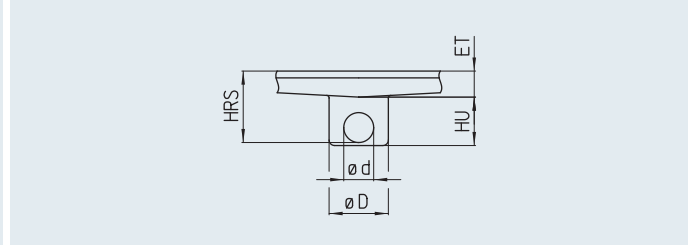
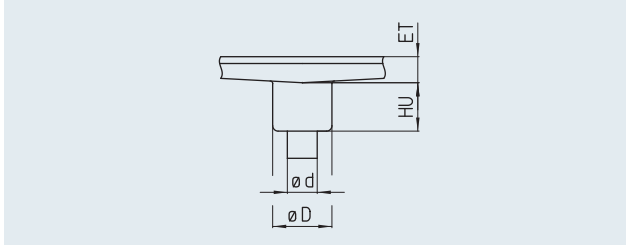

**Description for use in tenders**

Industrial channel, Model IKR, edge protection and internal grate support edge reinforced with rectangular stainless steel profile, the outer rectangular profile is 50 mm high to enable a better join. With wall anchors every 500 mm all round and U-shaped assembly supports for force-fit floor connection and adjustable height dowel installation feet every 1,000 mm. Fall 0.6 %. Channel available welded, not flanged, with welded / underwelded channel drain. Surface grain blasted.

Channel length:	L = ..... mm						
Grade:	• 1.4301 [AISI 304]		• 1.4571 [AISI 316 Ti] <sup>8)</sup>				
International width	• 70-150	• 90-170	• 120-200	• 170-250	• 220-300	• 320-400	• 420-500
Overall width:							
Cover:	• Plate cover, M125 • Grating MW25 Support rod 25/2RH		• Bar grate, M125 • Grating MW25 Support rod 25/3RH		• Plate cover, 3 mm • Grating MW25 Support rod 25/4RH		
Optional	Inlet rim:	• Attachment flange • Bonding flange		• Tile connection angle 30 x 30, perforated • Tile connection angle 30 x 30, unperforated		• other dimensions on request	
	Assembly foot:	Assembly feet for positioning on sealing sheet					
	Fall:	• 1 %		• ..... %			
<b>Channel drain</b>							
Model:	• RBE DRS ...	• RBE DRS ...	• RSKE ... <sup>10)</sup>	• RSK H ... <sup>10)</sup>	• GKSE ... <sup>10)</sup>		
Nominal width:	• DN 70	• DN 100	• DN 150				
Outlet:	• vertical		• horizontal				

We will be pleased to provide a description for specific objects for use in tenders.  
<sup>6)</sup> further nominal widths on request <sup>7)</sup> if no data is given the initial depth AT is at least 60 mm <sup>8)</sup> all parts in contact with media in 1.4571 (AISI 316 Ti)  
<sup>9)</sup> valid when ≤ ET 100 mm; when ET > 100 mm H and RS increase correspondingly <sup>10)</sup> see page on channel drains <sup>11)</sup> wall anchors not needed



## Industrial channel IKR

■ with plug-in channel drain

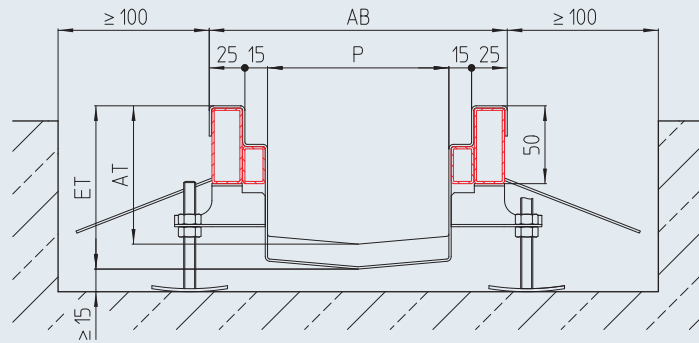
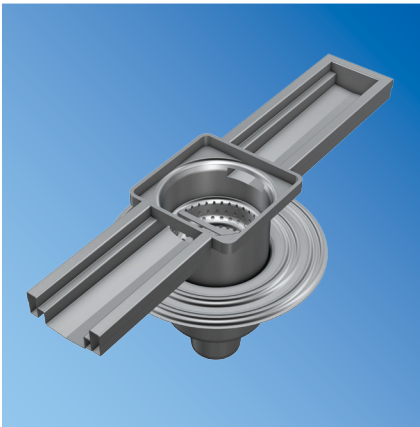

Channel model	P [mm]	AB [mm]	AT <sup>7)</sup>	Fall	ET [mm]
IKR-070-150	70	150	60	0.6%	
IKR-090-170	90	170	60	0.6%	
IKR-120-200	120	200	60	0.6%	
IKR-170-250	170	250	60	0.6%	
IKR-220-300	220	300	60	0.6%	
IKR-320-400	320	400	60	0.6%	
IKR-420-500	420	500	60	0.6%	

**Calculation ET:**  $AT + L1 \times 0,006$  [AT; ET; L1 in mm]

### Grade

■ 1.4301 (AISI 304) ■ 1.4571 (AISI 316 Ti)<sup>1)</sup>

### Cover variants

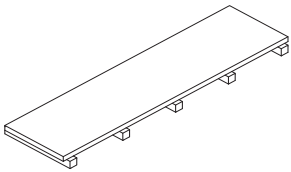

■ Plate cover M125

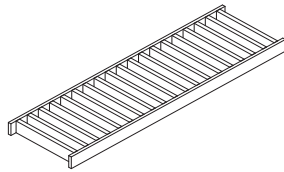

■ Bar grate cover M125

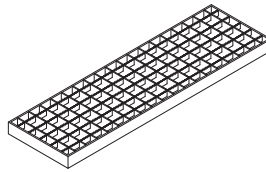

■ Grating cover L15

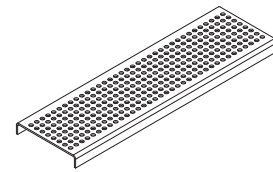

■ Plate cover, 3,0 mm K3

### Floor connection (optional)

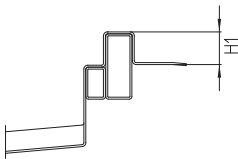

**AF** Attachment flange<sup>1)</sup>

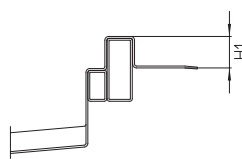

**HF** Bonding flange<sup>1)</sup>

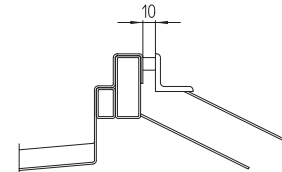

**FAWI** Tile connection angle

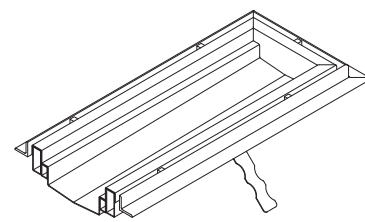
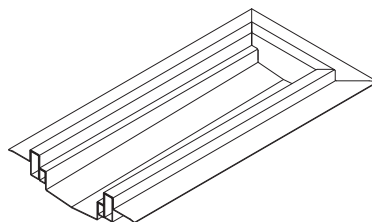
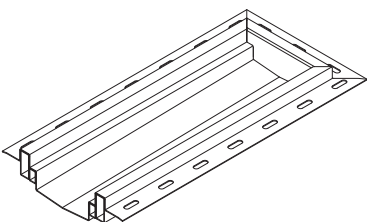

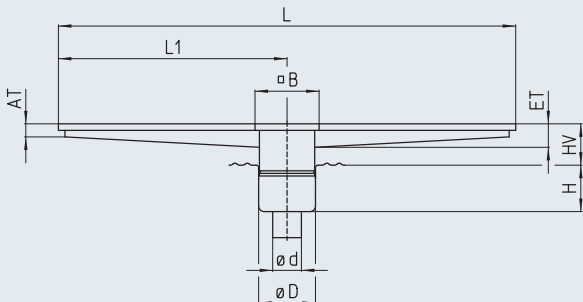
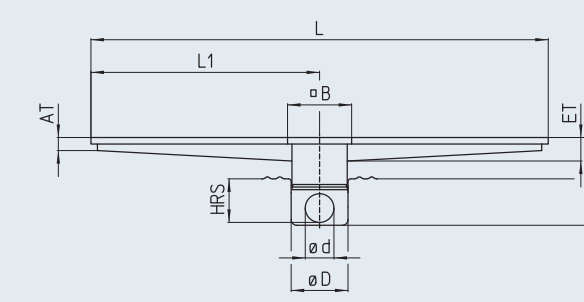

Channel drain <sup>6)</sup> – vertical – two-part								Channel drain <sup>6)</sup> – horizontal – two-part								
Model	DN	Ø d [mm]	∅ B [mm]	Ø D [mm]	H [mm]	to IKR-...	from IKR-...	Model	DN	Ø d [mm]	∅ B [mm]	Ø D [mm]	H [mm]	HRS [mm]	to IKR-...	from IKR-...
RBEH-070-E-S	70	75	180	153	129	70-150	-	RBEH-070-E-W	70	75	180	153	160	142	70-150	-
RBEH-100-E-S	100	110	246	218	178	120-200	-	RBEH-100-E-W	100	110	246	218	178	167	120-200	-
RBEH-150-E-S	150	160	310	283	209	170-250	-	RBEH-150-E-W	150	160	310	283	233	217	170-250	-

Channel drain <sup>6)</sup> – vertical – two-part						Channel drain <sup>6)</sup> – horizontal – two-part								
Model	DN	Ø d [mm]	Ø D [mm]	H [mm]	to IKR-...	from IKR-...	Model	DN	Ø d [mm]	Ø D [mm]	H [mm]	HRS [mm]	to IKR-...	from IKR-...
RBEH-070-S	70	75	153	129	-	170-250	RBEH-070-W	70	75	153	160	142	-	170-250
RBEH-100-S	100	110	218	178	-	220-300	RBEH-100-W	100	110	218	178	167	-	220-300
RBEH-150-S	150	160	283	209	-	320-400	RBEH-150-W	150	160	283	233	217	-	320-400

### Description for use in tenders

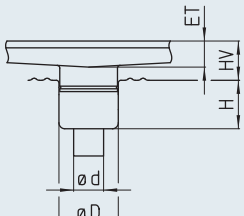
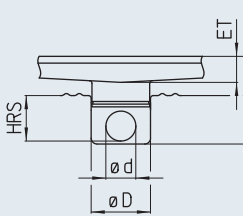
Industrial channel, Model IKR, edge protection and internal grate support edge reinforced with rectangular stainless steel profile, the outer rectangular profile is 50 mm high to enable a better join. With wall anchors every 500 mm all round and U-shaped assembly supports for force-fit inlet rim connection and adjustable height dowel installation feet every 1,000 mm. Fall 0.6% . Channel available welded, not flanged, with welded attachment piece / underwelded plug-in adapter. Surface grain blasted.

Channel length:	L = ..... mm						
Grade:	• 1.4301 [AISI 304]		• 1.4571 [AISI 316 Ti] <sup>8)</sup>				
Internal width:	• 70-150	• 90-170	• 120-200	• 170-250	• 220-300	• 320-400	• 420-500
Overall width:							
Cover:	• Plate cover, M125 • Grating MW25 Support rod 25/2RH		• Bar grate, M125 • Grating MW25 Support rod 25/3RH		• Plate cover, 3 mm • Grating MW25 Support rod 25/4RH		
Optional	Inlet rim:	• Attachment flange • Bonding flange		• Tile connection angle 30 x 30, perforated • Tile connection angle 30 x 30, unperforated		• other dimensions on request	
	Assembly foot:	Assembly feet for positioning on sealing sheet					
	Fall:	• 1 %		• ..... %			
<b>Channel drain</b>							
Model:	• RBEH ...						
Nominal width:	• DN 70	• DN 100	• DN 150				
Outlet:	• vertical		• horizontal				

We will be pleased to provide a description for specific objects for use in tenders.

<sup>6)</sup> further nominal widths on request <sup>7)</sup> if no data is given the initial depth AT is at least 60 mm <sup>8)</sup> all parts in contact with media in 1.4571 (AISI 316 Ti)

<sup>11)</sup> wall anchors not needed



# Commercial channel GKR

■ with welded/underwelded channel drain

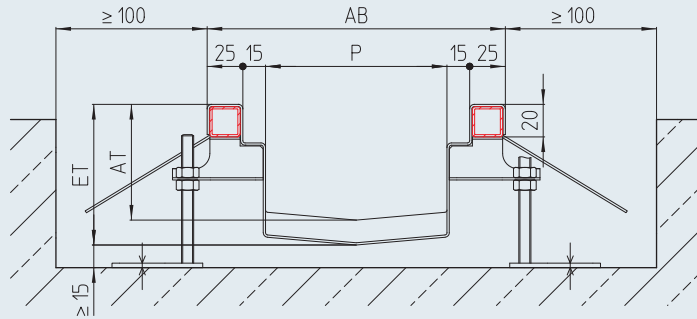
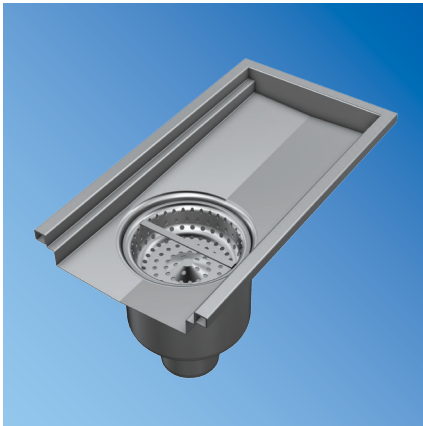
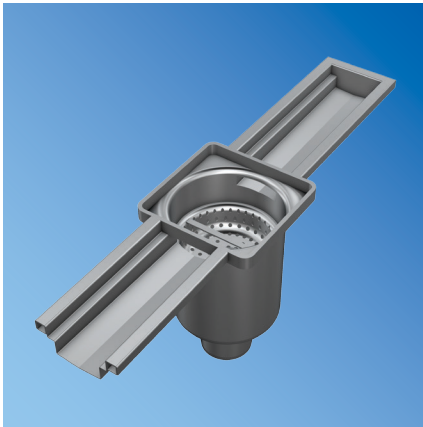

Channel model	P [mm]	AB [mm]	AT <sup>7)</sup>	Fall	ET [mm]
GKR-070-150	70	150	60	0.6%	
GKR-090-170	90	170	60	0.6%	
GKR-120-200	120	200	60	0.6%	
GKR-170-250	170	250	60	0.6%	
GKR-220-300	220	300	60	0.6%	
GKR-320-400	320	400	60	0.6%	
GKR-420-500	420	500	60	0.6%	

Calculation ET:  $AT + L1 \times 0,006$  [AT; ET; L1 in mm]

## Grade

■ 1.4301 (AISI 304) ■ 1.4571 (AISI 316 Ti)<sup>1)</sup>

## Cover variants

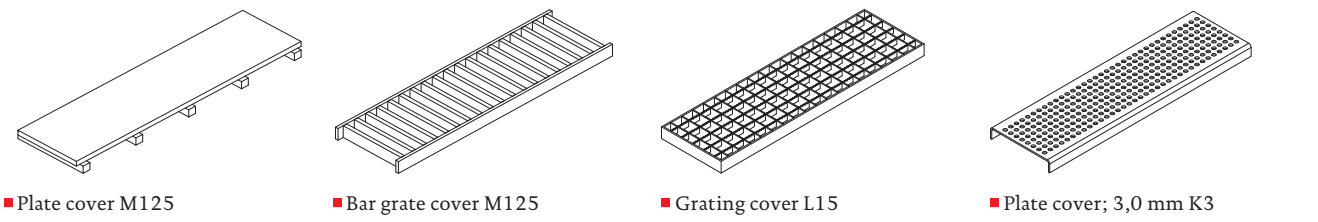

## Floor connection (optional)

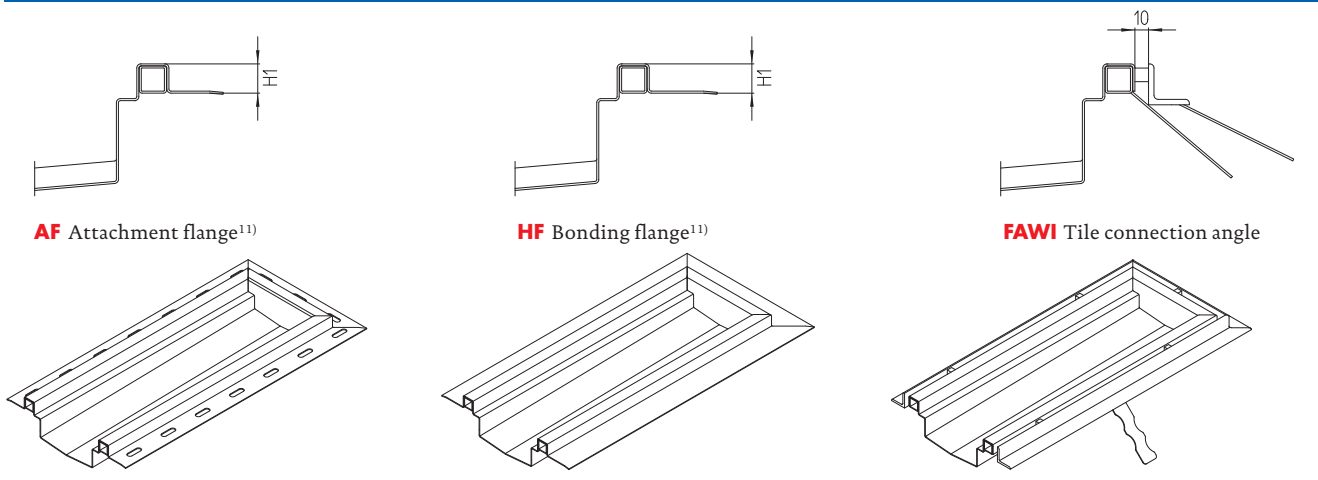

Channel drain <sup>6)</sup> – vertical – welded – single-part								Channel drain <sup>6)</sup> – horizontal – welded – single-part								
Model	DN	Ø d [mm]	∅ B [mm]	Ø D [mm]	H <sup>9)</sup> [mm]	to GKR-...	from GKR-...	Model	DN	Ø d [mm]	∅ B [mm]	Ø D [mm]	H <sup>9)</sup> [mm]	HRS <sup>9)</sup> [mm]	to GKR-...	from GKR-...
RBE DRS-070-E-S	70	75	180	153	280	70-150	-	RBE DRS-070-E-W	70	75	180	153	265	247	70-150	-
RBE DRS-100-E-S	100	110	246	218	300	120-200	-	RBE DRS-100-E-W	100	110	246	218	300	289	120-200	-
RBE DRS-150-E-S	150	160	310	283	355	170-250	-	RBE DRS-150-E-W	150	160	310	283	365	349	170-250	-

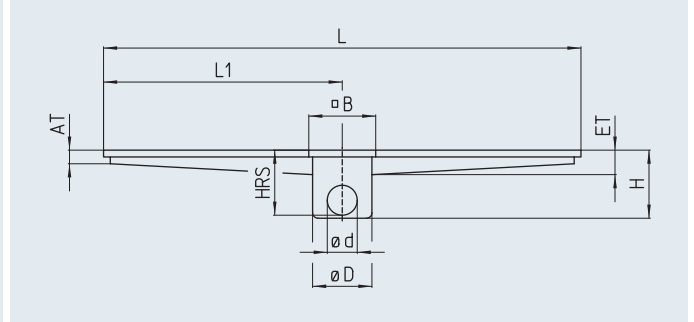
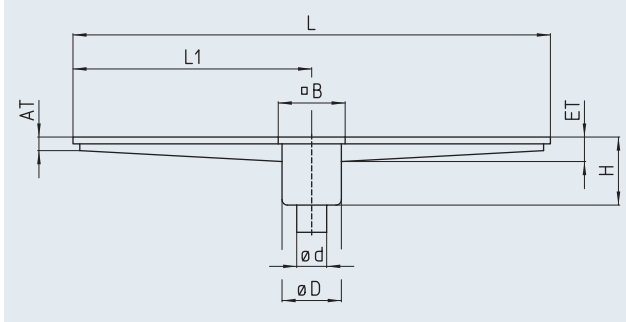

Channel drain <sup>6)</sup> – vertical – underwelded – single-part							Channel drain <sup>6)</sup> – horizontal – underwelded – single-part							
Model	DN	Ø d [mm]	Ø D [mm]	HU [mm]	to GKR-...	from GKR-...	Model	DN	Ø d [mm]	Ø D [mm]	HU [mm]	HRS [mm]	to GKR-...	from GKR-...
RBE DRS-070-S	70	75	153	161	-	170-250	RBE DRS-070-W	70	75	153	161	143	-	170-250
RBE DRS-100-S	100	110	218	195	-	220-300	RBE DRS-100-W	100	110	218	195	184	-	220-300
RBE DRS-150-S	150	160	283	235	-	320-400	RBE DRS-150-W	150	160	283	276	260	-	320-400

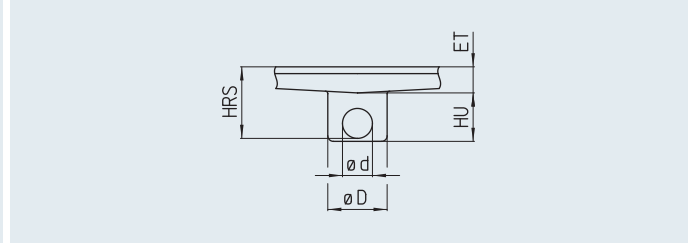
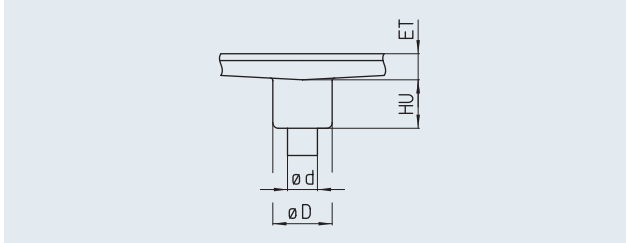

### Description for use in tenders

Commercial channel, Model GKR, Internally mounted edge protection reinforced with rectangular stainless steel profile. With wall anchors every 500 mm all round and U-shaped assembly supports for force-fit floor connection and adjustable height dowel installation feet every 1,000 mm. Fall 0.6%. Channel available welded, not flanged, with welded / underwelded channel drain. Surface grain blasted.

Channel length:	L = ..... mm						
Grade:	• 1.4301 [AISI 304]		• 1.4571 [AISI 316 Ti] <sup>8)</sup>				
Internal width	• 70-150	• 90-170	• 120-200	• 170-250	• 220-300	• 320-400	• 420-500
Overall width:							
Cover:	• Plate cover, M125 • Grating MW25 Support rod 25/2RH		• Bar grate, M125 • Grating MW25 Support rod 25/3RH		• Plate cover, 3 mm • Grating MW25 Support rod 25/4RH		
Optional	Inlet rim:	• Attachment flange • Bonding flange		• Tile connection angle 30 x 30, perforated • Tile connection angle 30 x 30, unperforated		• other dimensions on request	
	Assembly foot:	Assembly feet for positioning on sealing sheet					
	Fall:	• 1 %		• ..... %			
<b>Channel drain</b>							
Model:	• RBE DRS ...	• RBE DRS ...	• RSKE ... <sup>10)</sup>	• RSKH ... <sup>10)</sup>	• GKSE ... <sup>10)</sup>		
Nominal width:	• DN 70	• DN 100	• DN 150				
Outlet:	• vertical		• horizontal				

We will be pleased to provide a description for specific objects for use in tenders.

<sup>6)</sup> further nominal widths on request <sup>7)</sup> if no data is given the initial depth AT is at least 60 mm <sup>8)</sup> all parts in contact with media in 1.4571 (AISI 316 Ti)

<sup>9)</sup> valid when ≤ ET 100 mm; when ET > 100 mm H and RS increase correspondingly <sup>10)</sup> see page on channel drains <sup>11)</sup> wall anchors not needed



# Commercial channel GKR

■ with plug-in channel drain

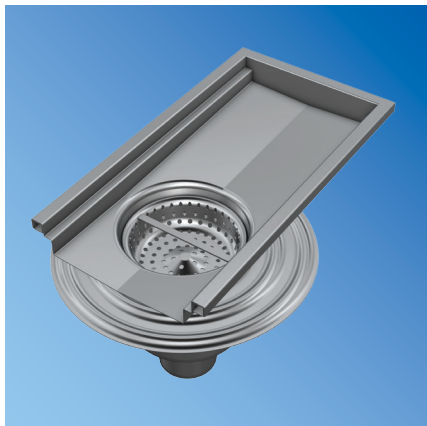
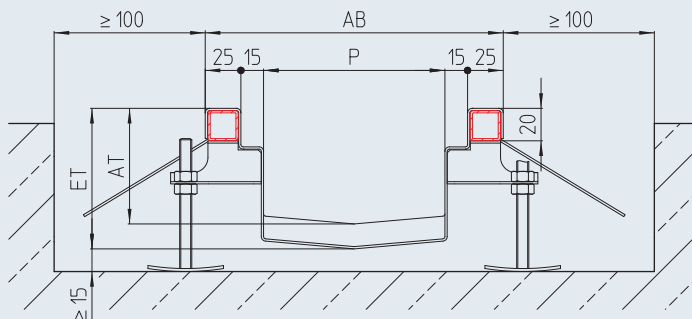
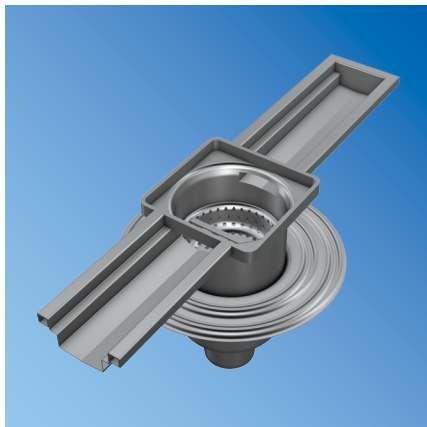

Channel model	P [mm]	AB [mm]	AT <sup>7)</sup>	Fall	ET [mm]
GKR-070-150	70	150	60	0.6%	
GKR-090-170	90	170	60	0.6%	
GKR-120-200	120	200	60	0.6%	
GKR-170-250	170	250	60	0.6%	
GKR-220-300	220	300	60	0.6%	
GKR-320-400	320	400	60	0.6%	
GKR-420-500	420	500	60	0.6%	

**Calculation ET:**  $AT + L1 \times 0,006$  [AT; ET; L1 in mm]

## Grade

■ 1.4301 (AISI 304) ■ 1.4571 (AISI 316 Ti)<sup>1)</sup>

## Cover variants

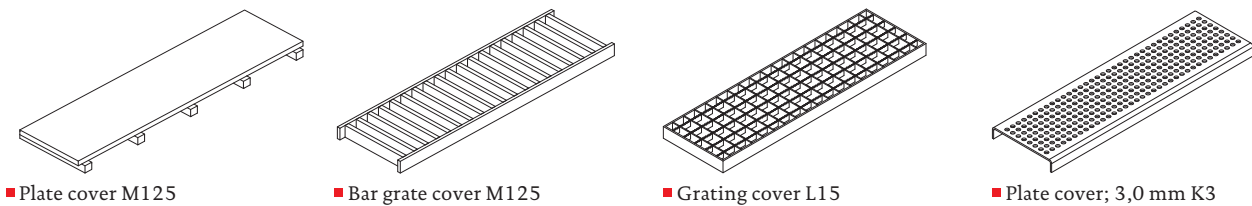

■ Plate cover M125      ■ Bar grate cover M125      ■ Grating cover L15      ■ Plate cover; 3,0 mm K3

## Floor connection (optional)

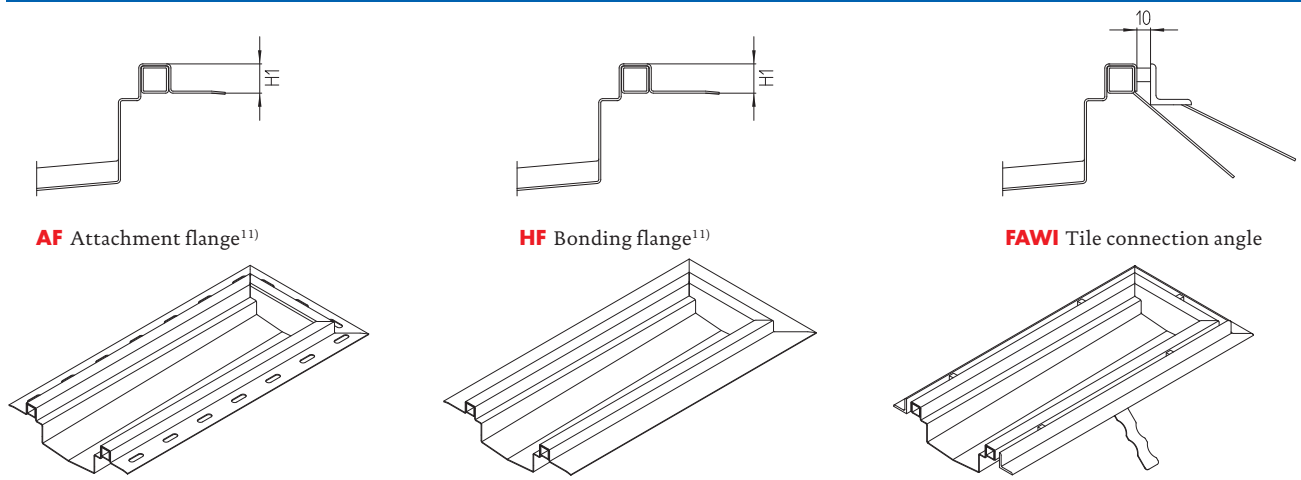

**AF** Attachment flange<sup>1)</sup>      **HF** Bonding flange<sup>1)</sup>      **FAWI** Tile connection angle

Channel drain <sup>6)</sup> – vertical – two-part								Channel drain <sup>6)</sup> – horizontal – two-part								
Model	DN	Ø d [mm]	Ø B [mm]	Ø D [mm]	H [mm]	to GKR-...	from GKR-...	Model	DN	Ø d [mm]	Ø B [mm]	Ø D [mm]	H [mm]	HRS [mm]	to GKR-...	from GKR-...
RBEH-070-E-S	70	75	180	153	129	70-150	-	RBEH-070-E-W	70	75	180	153	160	142	70-150	-
RBEH-100-E-S	100	110	246	218	178	120-200	-	RBEH-100-E-W	100	110	246	218	178	167	120-200	-
RBEH-150-E-S	150	160	310	283	209	170-250	-	RBEH-150-E-W	150	160	310	283	233	217	170-250	-

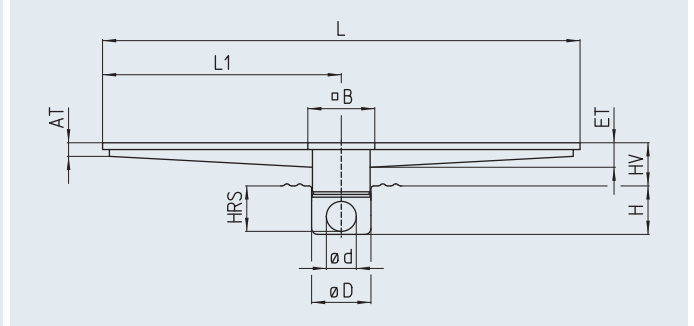
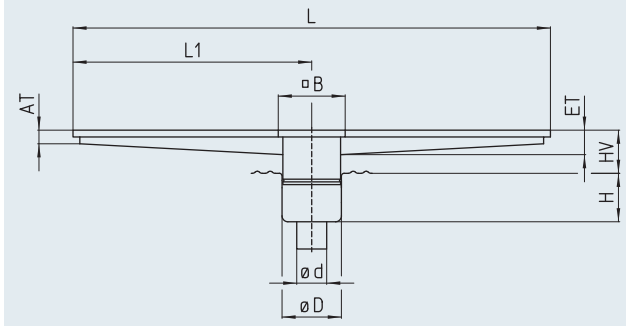

Channel drain <sup>6)</sup> – vertical – two-part							Channel drain <sup>6)</sup> – horizontal – two-part							
Model	DN	Ø d [mm]	Ø D [mm]	H [mm]	to GKR-...	from GKR-...	Model	DN	Ø d [mm]	Ø D [mm]	H [mm]	HRS [mm]	to GKR-...	from GKR-...
RBEH-070-S	70	75	153	129	-	170-250	RBEH-070-W	70	75	153	160	142	-	170-250
RBEH-100-S	100	110	218	178	-	220-300	RBEH-100-W	100	110	218	178	167	-	220-300
RBEH-150-S	150	160	283	209	-	320-400	RBEH-150-W	150	160	283	233	217	-	320-400

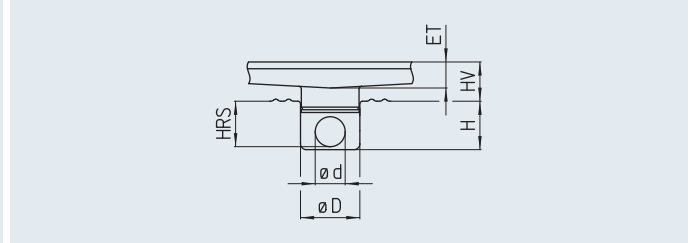
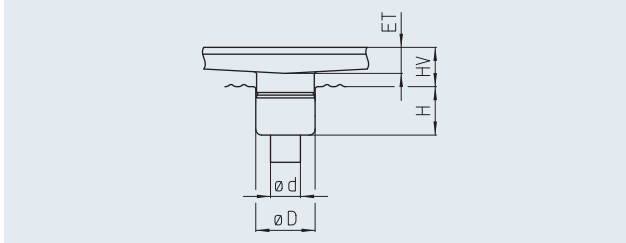

### Description for use in tenders

Commercial channel, Model GKR, Internally mounted edge protection reinforced with rectangular stainless steel profile. With wall anchors every 500 mm all round and U-shaped assembly supports for force-fit floor connection and adjustable height dowel installation feet every 1,000 mm. Fall 0.6%. Channel available welded, not flanged, with welded / underwelded connection piece/ underwelded plug-in adapter. Surface grain blasted.

Channel length:	L = ..... mm							
Grade:	• 1.4301 [AISI 304]		• 1.4571 [AISI 316 Ti] <sup>8)</sup>					
Internal width:	• 70-150	• 90-170	• 120-200	• 170-250	• 220-300	• 320-400	• 420-500	
Overall width:								
Cover:	• Plate cover, M125 • Grating MW25 Support rod 25/2RH		• Bar grate, M125 • Grating MW25 Support rod 25/3RH		• Plate cover, 3 mm • Grating MW25 Support rod 25/4RH			
Optional	Inlet rim:	• Attachment flange • Bonding flange		• Tile connection angle 30 x 30, perforated • Tile connection angle 30 x 30, unperforated			• other dimensions on request	
	Assembly foot:	Assembly feet for positioning on sealing sheet						
	Fall:	• 1 %		• ..... %				
<b>Channel drain</b>								
Model:	• RBEH ...							
Nominal width:	• DN 70	• DN 100	• DN 150					
Outlet:	• vertical			• horizontal				

We will be pleased to provide a description for specific objects for use in tenders.

<sup>6)</sup> further nominal widths on request <sup>7)</sup> if no data is given the initial depth AT is at least 60 mm <sup>8)</sup> all parts in contact with media in 1.4571 (AISI 316 Ti)

<sup>11)</sup> Wall anchors not needed



# Vario channel VKR

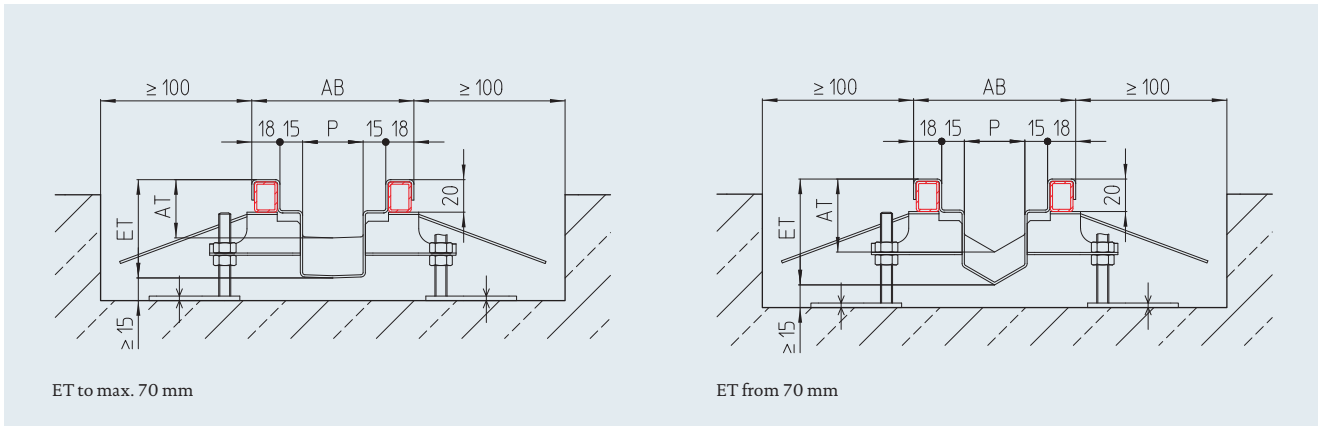
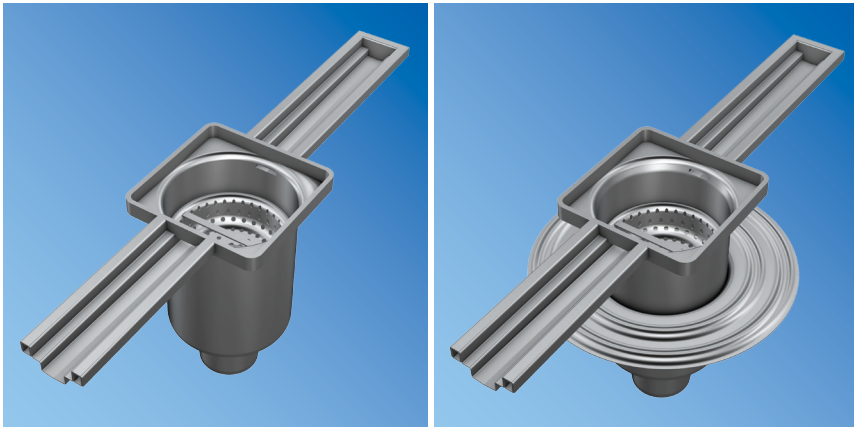

Channel model	P [mm]	AB [mm]	AT <sup>1)</sup>	Fall	ET [mm]
VKR	40	106	40	0.6 %	

Calculation ET:  $AT + L1 \times 0,006$  [AT; ET; L1 in mm]

**Grade**

■ 1.4301 (AISI 304) ■ 1.4571 (AISI 316 Ti)<sup>1)</sup>

## Floor connection (optional)

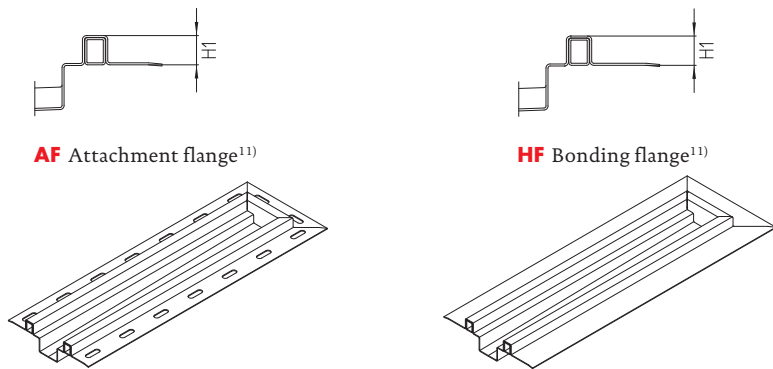

Channel drain <sup>6)</sup> – vertical – single-part					
Model	DN	Ø d [mm]	∅ B [mm]	Ø D [mm]	H <sup>9)</sup> [mm]
RBE DRS-070-E-S	70	75	180	153	280
RBE DRS-100-E-S	100	110	246	218	300
RBE DRS-150-E-S	150	160	310	283	355

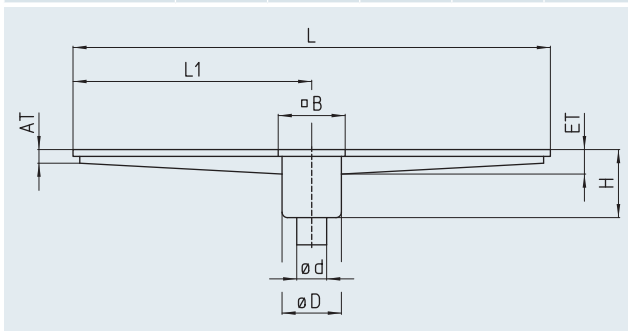

Channel drain <sup>6)</sup> – horizontal – single-part						
Model	DN	Ø d [mm]	∅ B [mm]	Ø D [mm]	H <sup>9)</sup> [mm]	HRS <sup>9)</sup>
RBE DRS-070-E-W	70	75	180	153	265	247
RBE DRS-100-E-W	100	110	246	218	300	289
RBE DRS-150-E-W	150	160	310	283	365	349

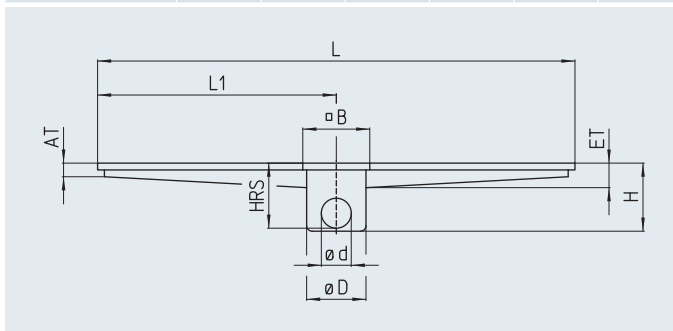

Channel drain <sup>6)</sup> – vertical – two-part					
Model	DN	Ø d [mm]	∅ B [mm]	Ø D [mm]	H [mm]
RBE DRS-070-E-S	70	75	180	153	129
RBE DRS-100-E-S	100	110	246	218	178
RBE DRS-150-E-S	150	160	310	283	209

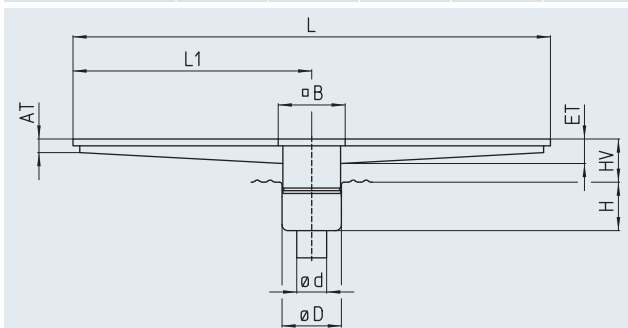

Channel drain <sup>6)</sup> – horizontal – two-part						
Model	DN	Ø d [mm]	∅ B [mm]	Ø D [mm]	H [mm]	HRS [mm]
RBE DRS-070-E-W	70	75	180	153	160	142
RBE DRS-100-E-W	100	110	246	218	178	167
RBE DRS-150-E-W	150	160	310	283	233	217

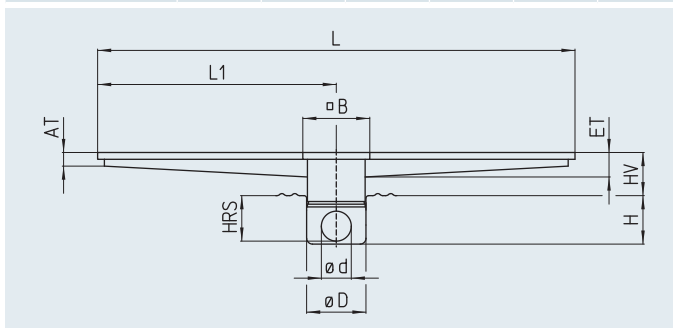

### Description for use in tenders

Vario channel, Model VKR, internally mounted edge protection reinforced with rectangular stainless steel profile. With wall anchors every 500 mm all round and U-shaped assembly supports for force-fit floor connection and adjustable height dowel installation feet every 1,000 mm. 40 mm profile width and fall 0.6 %. Channel available welded, not flanged, with welded channel floor inlet. Surface grain blasted.

Channel length:	L = ..... mm	
Grade:	• 1.4301 [AISI 304]	• 1.4571 [AISI 316 Ti] <sup>8)</sup>

Optional

Inlet rim:	• Attachment flange • Bonding flange
Assembly foot:	Assembly feet for positioning on sealing sheet (FT)

#### Channel drain

Model:	• RBE DRS ...	• RBE H ...	
Nominal width:	• DN 70	• DN 100	• DN 150
Outlet:	• vertical	• horizontal	

We will be pleased to provide a description for specific objects for use in tenders.

<sup>6)</sup> further nominal widths on request <sup>8)</sup> all parts in contact with media in 1.4571 (AISI 316 Ti) <sup>9)</sup> valid when ≤ ET 100 mm; when ET > 100 mm H and RS increase correspondingly

<sup>11)</sup> Wall anchors not needed

## Kitchen channel plinth combination KRS

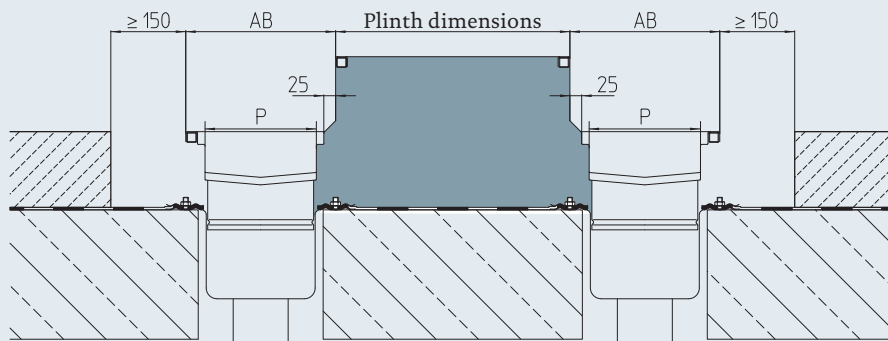
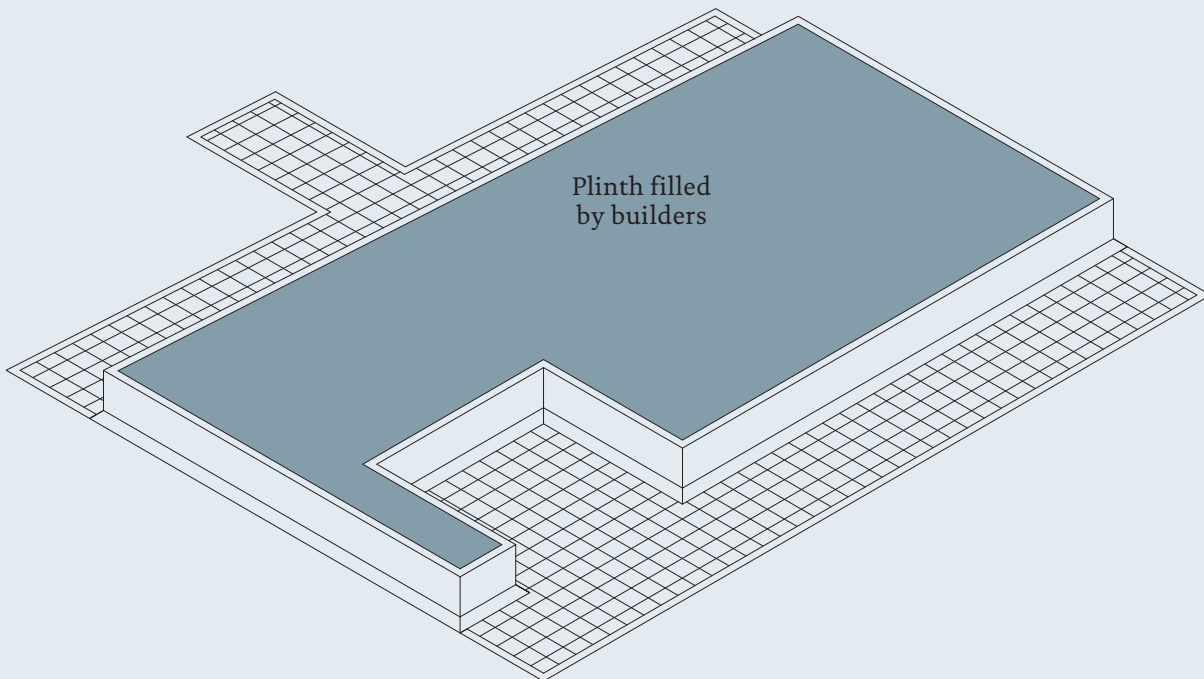

	P [mm]	AB [mm]	AT <sup>7)</sup>	Fall	ET [mm]
KRS-220-300	220	300	60	0.6 %	
KRS-320-400	320	400	60	0.6 %	
KRS-420-500	420	500	60	0.6 %	

**Calculation ET:**  $AT + L1 \times 0,006$  [AT; ET; L1 in mm]

### Grade

■ 1.4301 (AISI 304) ■ 1.4571 (AISI 316 Ti)<sup>1)</sup>

### Cover variants

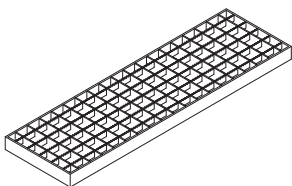

■ Grating cover L15



**Floor connection (optional)**

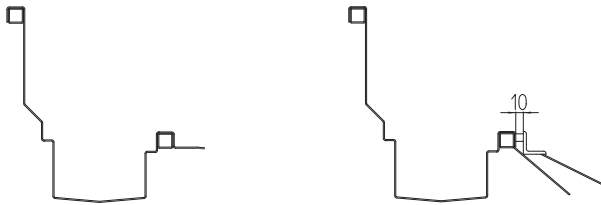

**HF** Bonding flange<sup>11)</sup>  
**AF** Attachment flange<sup>11)</sup>

■ Tile connection angle

**Description for use in tenders**

Kitchen channel plinth combination Model KRS, one-piece, seamless. Internally mounted edge protection reinforced with rectangular stainless steel profile. Channel with wall anchors every 500 mm all round and U-shaped assembly supports for force-fit floor connection and adjustable height dowel installation feet every 1,000 mm. Fall 0.6 %. Channel available welded, not flanged, with underwelded / plug-in channel drain. Surface grain blasted.

Plinth dimension:	L = ..... mm	B = ..... mm	H = ..... mm
Main channel 1:	L = ..... mm	AB = ..... mm	
Main channel 2:	L = ..... mm	AB = ..... mm	
Optional	Outside branch channel:	L = ..... mm	AB = ..... mm
	Inside branch channel:	L = ..... mm	AB = ..... mm
Grade:	• 1.4301 [AISI 304]	• 1.4571 [AISI 316 Ti] <sup>8)</sup>	
Cover:	• Grating MW25 Support rod 25/2RH	• Grating MW25 Support rod 25/3RH	• Grating MW25 Support rod 25/4RH
Optional	Inlet rim:	• Attachment flange • Bonding flange	• Tile connection angle 30 x 30, perforated • Tile connection angle 30 x 30, unperforated • other dimensions on request
	Assembly foot:	Assembly feet for positioning on sealing sheet (FT)	
	Longitudinal gradient:	• 1 %	• ..... %
<b>Channel drain</b>			
Model:	• RBEH ...	• RBE DRS ...	
Nominal width:	• DN 70	• DN 100	
Outlet:	• vertical	• horizontal	

We will be pleased to provide a description for specific objects for use in tenders.

<sup>7)</sup> if no data is given the initial depth AT is at least 60 mm <sup>8)</sup> all parts in contact with media in 1.4571 (AISI 316 Ti) <sup>11)</sup> Wall anchors not needed



# Slot channel SRD

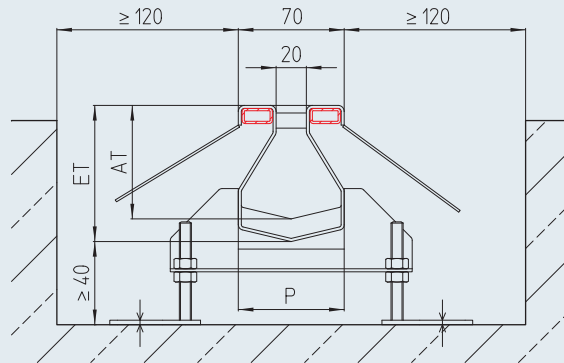
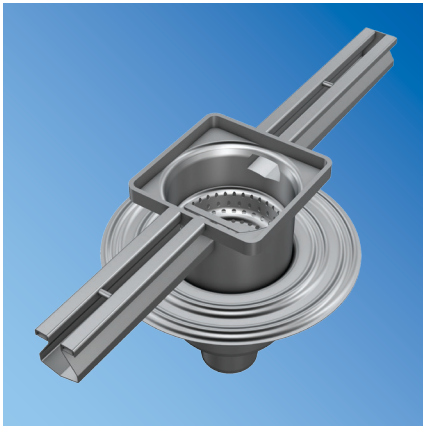
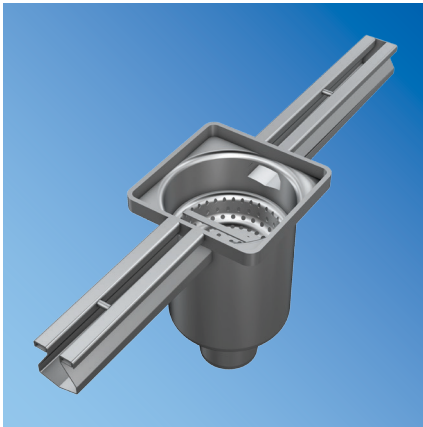

Channel model	P [mm]	AT <sup>2)</sup> [mm]	Fall	ET [mm]
SRD-70	70	75	0.6 %	
SRD-90	90	110	0.6 %	

**Calculation ET:**  $AT + L1 \times 0,006$  [AT; ET; L1 in mm]

## Grade

■ 1.4301 (AISI 304) ■ 1.4571 (AISI 316 Ti)<sup>1)</sup>

## Floor connection (optional)

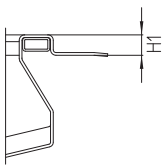

**AF** Attachment flange<sup>1)</sup>

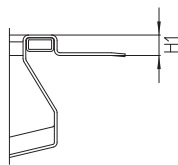

**HF** Bonding flange<sup>1)</sup>

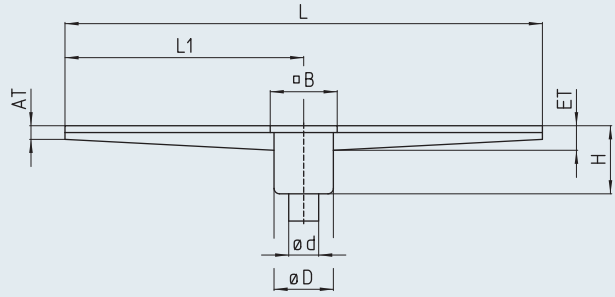
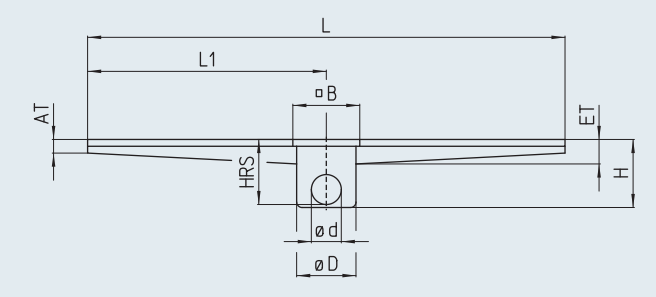

Channel drain <sup>6)</sup> – vertical – single-part						Channel drain <sup>6)</sup> – horizontal – single-part						
Model	DN	Ø d [mm]	Ø B [mm]	Ø D [mm]	H <sup>9)</sup> [mm]	Model	DN	Ø d [mm]	Ø B [mm]	Ø D [mm]	H <sup>9)</sup> [mm]	HRS <sup>9)</sup>
RBE DRS-070-E-S	70	75	180	153	280	RBE DRS-070-E-W	70	75	180	153	265	247
RBE DRS-100-E-S	100	110	246	218	300	RBE DRS-100-E-W	100	110	246	218	300	289
RBE DRS-150-E-S	150	160	310	283	355	RBE DRS-150-E-W	150	160	310	283	365	349

Channel drain <sup>6)</sup> – vertical – two-part						Channel drain <sup>6)</sup> – horizontal – two-part						
Model	DN	Ø d [mm]	Ø B [mm]	Ø D [mm]	H [mm]	Model	DN	Ø d [mm]	Ø B [mm]	Ø D [mm]	H [mm]	HRS [mm]
RBE H-070-E-S	70	75	180	153	129	RBE H-070-E-W	70	75	180	153	160	142
RBE H-100-E-S	100	110	246	218	178	RBE H-100-E-W	100	110	246	218	178	167
RBE H-150-E-S	150	160	310	283	209	RBE H-150-E-W	150	160	310	283	233	217

### Description for use in tenders

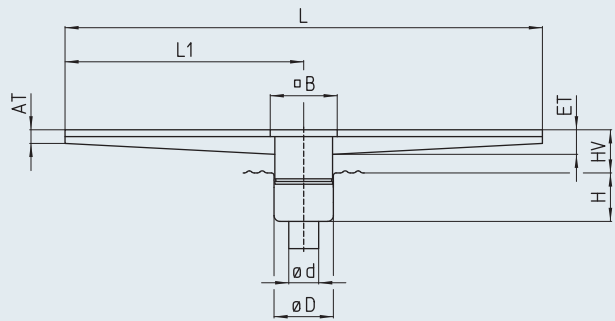
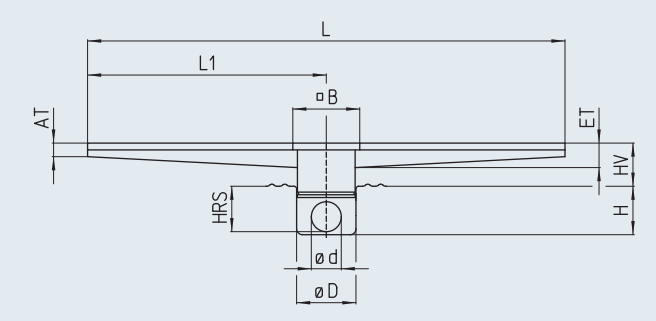
Slot channel, Model SRD, inlet slot width 20 mm with spacers. Internally mounted edge protection reinforced with rectangular stainless steel profile. Channel with wall anchors every 500 mm all round and L-shaped assembly supports for force-fit floor connection and adjustable height dowel installation feet every 1,000 mm. Inner cross fall and fall 0.6 %. Channel available welded, not flanged, with welded channel drain. Surface grain blasted.

Channel length:	L = ..... mm			
Grade:	• 1.4301 [AISI 304]	• 1.4571 [AISI 316 Ti] <sup>8)</sup>		
Width (P):	• 70	• 90		
Optional	Inlet rim:	• Attachment flange • Bonding flange		
	Assembly foot:	Assembly feet for positioning on sealing sheet		
<b>Channel drain</b>				
Model:	• RBE DRS ...	• RBE H ...		
Nominal width:	• DN 70	• DN 100	• DN 150	
Outlet:	• vertical	• horizontal		

We will be pleased to provide a description for specific objects for use in tenders.

<sup>6)</sup> further nominal widths on request <sup>8)</sup> all parts in contact with media in 1.4571 (AISI 316 Ti) <sup>9)</sup> valid when ≤ ET 100 mm; when ET > 100 mm H and RS increase correspondingly

<sup>10)</sup> Wall anchors not needed

## Heavy duty slot channel SRO

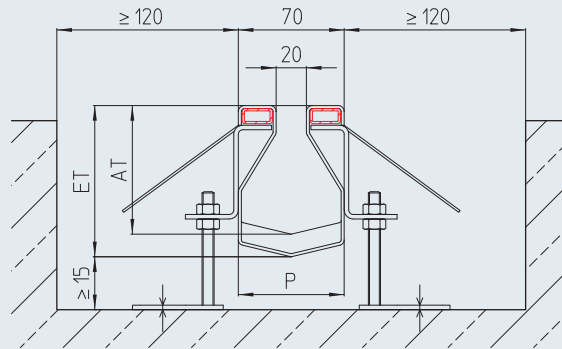
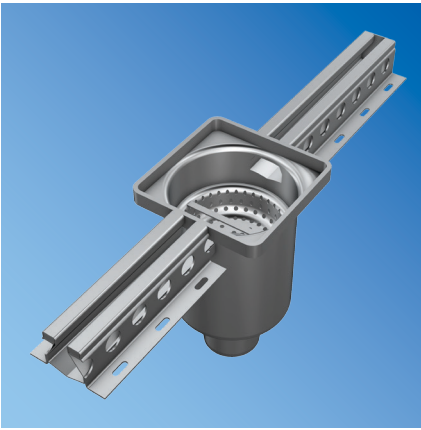

Channel model	P [mm]	AT <sup>2)</sup> [mm]	Fall	ET [mm]
SRO	70	75	0.6 %	

**Calculation ET:**  $AT + L1 \times 0,006$  [AT; ET; L1 in mm]

### Grade

■ 1.4301 (AISI 304) ■ 1.4571 (AISI 316 Ti)<sup>1)</sup>

Channel drain <sup>6)</sup> – vertical – welded – single-part						Channel drain <sup>6)</sup> – horizontal – welded – single-part						
Model	DN	Ø d [mm]	Ø B [mm]	Ø D [mm]	H <sup>9)</sup> [mm]	Model	DN	Ø d [mm]	Ø B [mm]	Ø D [mm]	H <sup>9)</sup> [mm]	HRS <sup>9)</sup>
RBE DRS-070-E-S	70	75	180	153	280	RBE DRS-070-E-W	70	75	180	153	265	247
RBE DRS-100-E-S	100	110	246	218	300	RBE DRS-100-E-W	100	110	246	218	300	289
RBE DRS-150-E-S	150	160	310	283	355	RBE DRS-150-E-W	150	160	310	283	365	349

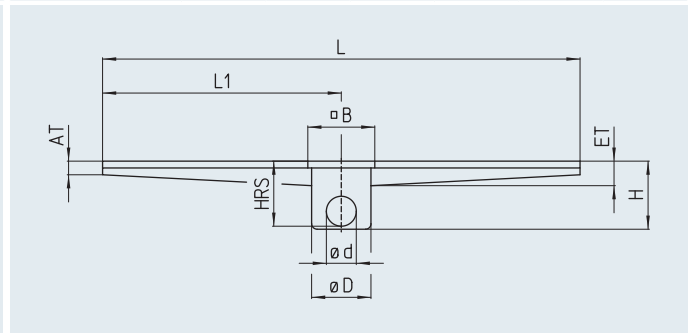
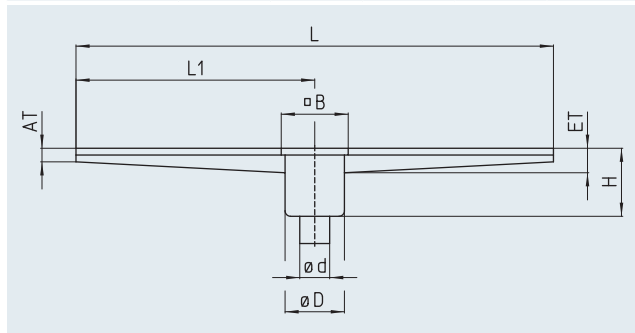

Channel drain <sup>6)</sup> – vertical – two-part						Channel drain <sup>6)</sup> – horizontal – two-part						
Model	DN	Ø d [mm]	Ø B [mm]	Ø D [mm]	H [mm]	Model	DN	Ø d [mm]	Ø B [mm]	Ø D [mm]	H [mm]	HRS [mm]
RBE H-070-E-S	70	75	180	153	129	RBE H-070-E-W	70	75	180	153	160	142
RBE H-100-E-S	100	110	246	218	178	RBE H-100-E-W	100	110	246	218	178	167
RBE H-150-E-S	150	160	310	283	209	RBE H-150-E-W	150	160	310	283	233	217

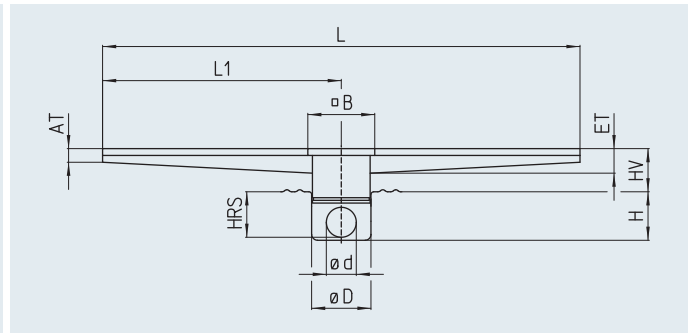
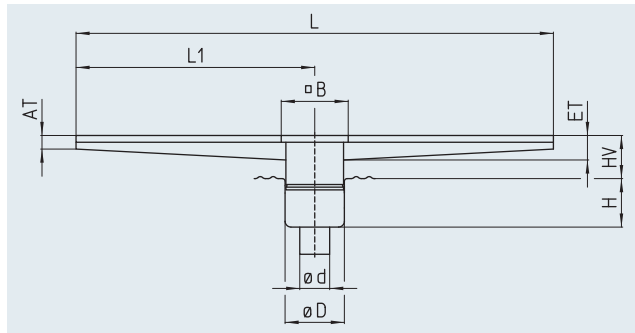

### Description for use in tenders

Heavy duty slot channel, Model SRO, inlet slot width 20 mm without spacers. Internally mounted edge protection reinforced with rectangular stainless steel profile and supported by a continuous 3 mm thick, perforated Z-profile, in order to achieve a better joint between channel and floor. With wall anchors every 500 mm all round and L-shaped assembly supports for force-fit floor connection and adjustable height dowel installation feet every 1,000 mm. 70 mm profile width with fall 0.6 %. Channel available welded, not flanged, with welded channel drain. Surface grain blasted.

Channel length:	L = ..... mm	
Grade:	• 1.4301 [AISI 304]	• 1.4571 [AISI 316 Ti] <sup>8)</sup>
Assembly foot:	Assembly feet for positioning on sealing sheet	

Opt.

Channel drain			
Model:	• RBE DRS ...	• RBE H ...	
Nominal width:	• DN 70	• DN 100	• DN 150
Outlet:	• vertical	• horizontal	

We will be pleased to provide a description for specific objects for use in tenders.

<sup>6)</sup> further nominal widths on request <sup>8)</sup> all parts in contact with media in 1.4571 (AISI 316 Ti) <sup>9)</sup> valid when ≤ ET 100 mm; when ET > 100 mm H and RS increase correspondingly <sup>10)</sup> see page on channel drains

## Heavy duty slot channel SRZ

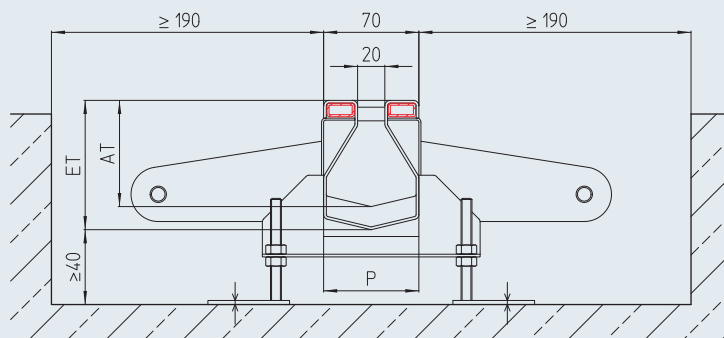
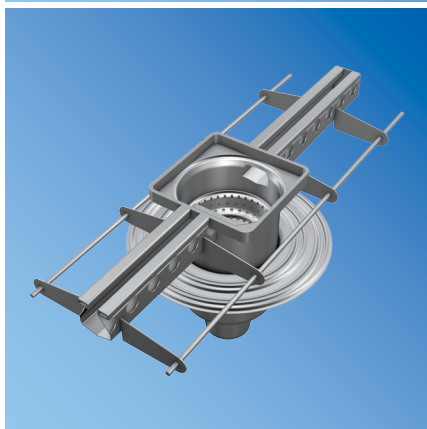

Channel model	P [mm]	AT <sup>2)</sup> [mm]	Fall	ET [mm]
SRZ-70	70	75	0.6 %	
SRZ-90	90	110	0.6 %	

**Calculation ET:**  $AT + L1 \times 0,006$  [AT; ET; L1 in mm]

### Grade

■ 1.4301 (AISI 304) ■ 1.4571 (AISI 316 Ti)<sup>1)</sup>

Channel drain <sup>6)</sup> – vertical – welded – single-part						Channel drain <sup>6)</sup> – horizontal – welded – single-part						
Model	DN	Ø d [mm]	Ø B [mm]	Ø D [mm]	H <sup>9)</sup> [mm]	Model	DN	Ø d [mm]	Ø B [mm]	Ø D [mm]	H <sup>9)</sup> [mm]	HRS <sup>9)</sup>
RBE DRS-070-E-S	70	75	180	153	280	RBE DRS-070-E-W	70	75	180	153	265	247
RBE DRS-100-E-S	100	110	246	218	300	RBE DRS-100-E-W	100	110	246	218	300	289
RBE DRS-150-E-S	150	160	310	283	355	RBE DRS-150-E-W	150	160	310	283	365	349

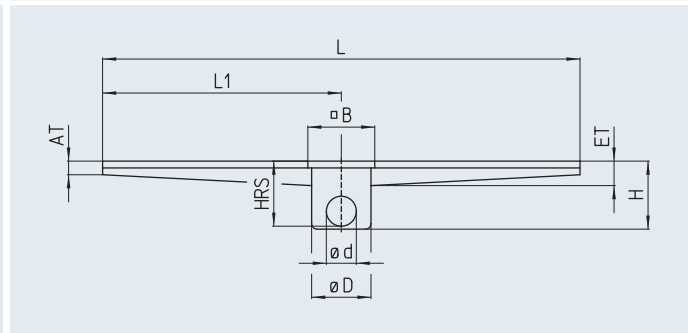
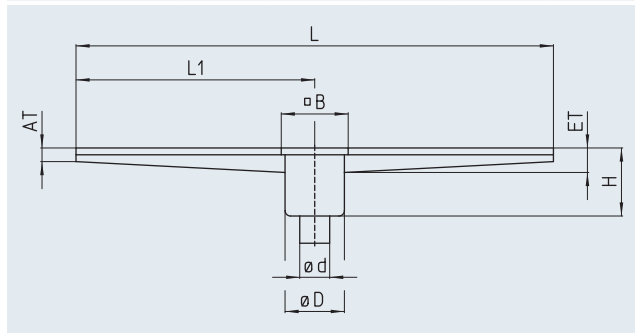

Channel drain <sup>6)</sup> – vertical – two-part						Channel drain <sup>6)</sup> – horizontal – two-part						
Model	DN	Ø d [mm]	Ø B [mm]	Ø D [mm]	H [mm]	Model	DN	Ø d [mm]	Ø B [mm]	Ø D [mm]	H [mm]	HRS [mm]
RBE H-070-E-S	70	75	180	153	129	RBE H-070-E-W	70	75	180	153	160	142
RBE H-100-E-S	100	110	246	218	178	RBE H-100-E-W	100	110	246	218	178	167
RBE H-150-E-S	150	160	310	283	209	RBE H-150-E-W	150	160	310	283	233	217

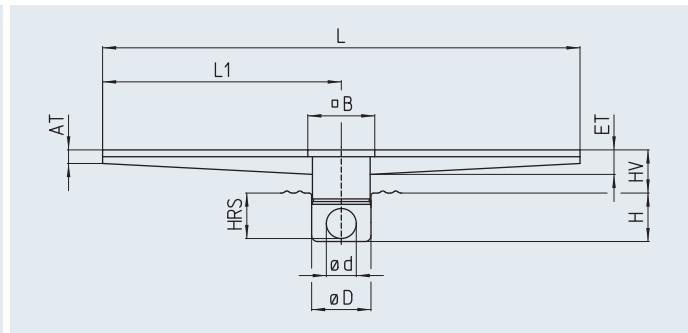
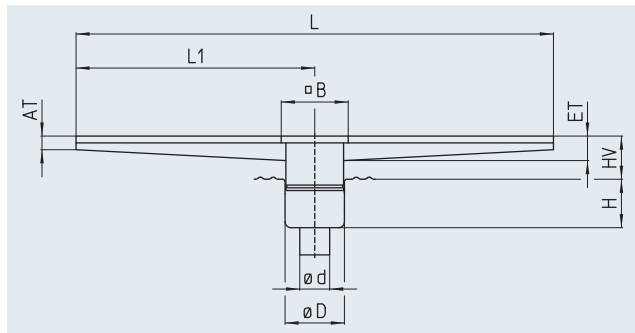

### Description for use in tenders

Heavy duty slot channel, Model SRZ, inlet slot width 20 mm without spacers. Internally mounted edge protection reinforced with rectangular stainless steel profile. Continuous attached perforated profile, overhanging lateral tie anchor every 500 mm, connected with reinforcing bars for a better connection of the whole channel to the floor. L-shaped assembly supports for force-fit floor connection and adjustable height dowel installation feet every 1,000 mm. Fall 0.6 %. Channel available welded, not flanged, with welded channel drain. Surface grain blasted.

Channel length:	L = ..... mm	
Grade:	• 1.4301 [AISI 304]	• 1.4571 [AISI 316 Ti] <sup>9)</sup>
Width (P):	• 70	• 90
Assembly foot:	Assembly feet for positioning on sealing sheet	
<b>Channel drain</b>		
Model:	• RBE DRS ...	• RBE H ...
Nominal width:	• DN 70	• DN 100
Outlet:	• vertical	• horizontal

We will be pleased to provide a description for specific objects for use in tenders.

<sup>6)</sup> further nominal widths on request <sup>9)</sup> all parts in contact with media in 1.4571 (AISI 316 Ti) <sup>9)</sup> valid when ≤ ET 100 mm; when ET > 100 mm H and RS increase correspondingly

## Slot channel SRD50

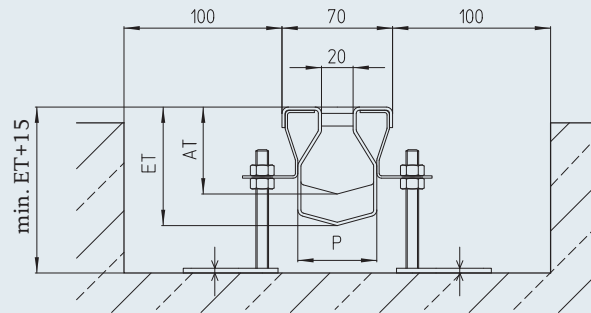
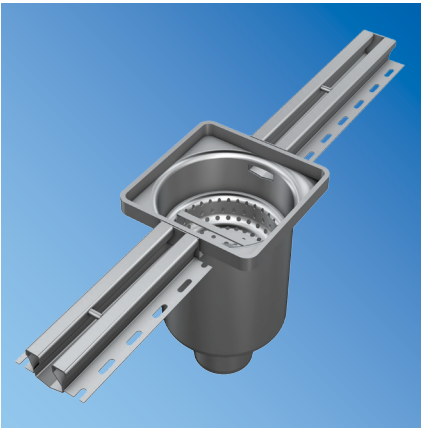

Channel model	P [mm]	AT <sup>12)</sup> [mm]	Fall	ET <sup>3)</sup> [mm]
SRD50	50	min. 55	0.6 %	max. 106

### Grade

■ 1.4301 (AISI 304) ■ 1.4571 (AISI 316 Ti)<sup>1)</sup>



Channel drain – vertical – welded – single-part						Channel drain – horizontal – welded – single-part						
Model	DN	Ø d [mm]	∅ B [mm]	Ø D [mm]	H [mm]	Model	DN	Ø d [mm]	∅ B [mm]	Ø D [mm]	H [mm]	HRS
RBE DRS-100-E-S	100	110	246	218	300	RBE DRS-100-E-W	100	110	246	218	300	289

Channel drain – vertical – two-part						Channel drain – horizontal – two-part						
Model	DN	Ø d [mm]	∅ B [mm]	Ø D [mm]	H [mm]	Model	DN	Ø d [mm]	∅ B [mm]	Ø D [mm]	H [mm]	HRS
RBE H-100-E-S	100	110	246	218	178	RBE H-100-E-W	100	110	246	218	178	167

### Description for use in tenders

Module slot channel, Model SRD50, inlet slot width 20 mm with spacers every 300 mm. Internally mounted edge protection reinforced with continuous stainless steel Z-profile. Adjustable height dowel installation feet every 1,000 mm fixed in horizontal arm of the Z-profile. 50 mm profile width and fall 0.6 %. Channel available flanged, with welded channel drain. Surface grain blasted.

Model No.: ..... (see next page)

Grade: • 1.4301 [AISI 304] • 1.4571 [AISI 316 Ti]<sup>9)</sup>

Opt. Assembly foot: Assembly feet for positioning on sealing sheet

#### Channel drain

Model: • RBE DRS-100-E- ... • RBE H-100-E- ...

Nominal width: • DN 100

Outlet: • vertical • horizontal

We will be pleased to provide a description for specific objects for use in tenders.

<sup>9)</sup> further nominal widths on request <sup>9)</sup> all parts in contact with media in 1.4571 (AISI 316 Ti) <sup>12)</sup> Please take AT from the module system <sup>13)</sup> Please take ET from the module system

## Module channel SRD50 Overview

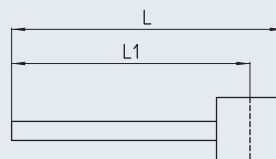
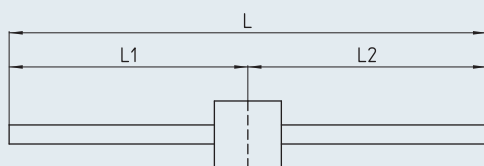

### Module channel one-sided

L (m)	L1 (m)	L2 (m)	ET (mm)	Model No.:
1.15	1.03		72	SRD50-009-09-10
2.80	1.53		80	SRD50-014-14-20
1.65	1.53		97	SRD50-014-14-40
2.15	2.03		72	SRD50-019-19-10
2.65	2.53		80	SRD50-024-24-20
3.15	3.03		72	SRD50-029-29-10
	3.03		89	SRD50-029-29-30
	3.03		106	SRD50-029-29-50
3.55	3.43		80	SRD50-033-33-20
4.05	3.93		89	SRD50-038-38-30
4.55	4.43		80	SRD50-043-43-20
	4.43		97	SRD50-043-43-40
5.05	4.93		89	SRD50-048-48-30
5.45	5.33		97	SRD50-052-52-40
6.05	5.93		89	SRD50-058-58-30
	5.93		106	SRD50-058-58-50
6.45	6.33		97	SRD50-062-62-40
6.95	6.83		106	SRD50-067-67-50
7.45	7.33		97	SRD50-072-72-40
8.95	8.83		106	SRD50-087-87-50

### Module channel two-sided

L (m)	L1 (m)	L2 (m)	ET (mm)	Model No.:
2.05	1.03	1.03	72	SRD50-018-09-11
2.55	1.03	1.53	80	SRD50-023-09-12
	1.03	1.53	97	SRD50-023-09-14
3.05	1.03	2.03	72	SRD50-028-09-11
	1.53	1.53	80	SRD50-028-14-22
	1.53	1.53	97	SRD50-028-14-44
	1.03	2.53	80	SRD50-033-09-12
3.55	1.53	2.03	80	SRD50-033-14-21
	1.53	2.03	97	SRD50-033-14-41
4.05	1.03	3.03	72	SRD50-038-09-11
	1.03	3.03	89	SRD50-038-09-13
	1.03	3.03	106	SRD50-038-09-15
	1.53	2.53	80	SRD50-038-14-22
	1.53	2.53	97	SRD50-038-14-42
4.45	2.03	2.03	72	SRD50-038-19-11
	1.03	3.43	80	SRD50-042-09-12
4.55	1.53	3.03	80	SRD50-043-14-21
	1.53	3.03	89	SRD50-043-14-23
	1.53	3.03	106	SRD50-043-14-25
	1.53	3.03	106	SRD50-043-14-45
	2.03	2.53	80	SRD50-043-19-12
4.95	1.03	3.93	89	SRD50-047-09-13
	1.53	3.43	80	SRD50-047-14-22
5.05	2.03	3.03	72	SRD50-048-19-11
	2.03	3.03	89	SRD50-048-19-13
	2.03	3.03	106	SRD50-048-19-15
	2.53	2.53	80	SRD50-048-24-22
5.45	1.03	4.43	80	SRD50-052-09-12
	1.03	4.43	97	SRD50-052-09-14
	1.53	3.93	89	SRD50-052-14-23
	2.03	3.43	80	SRD50-052-19-12
5.55	2.53	3.03	80	SRD50-052-24-21
	2.53	3.03	89	SRD50-052-24-23
	2.53	3.03	106	SRD50-052-24-25
5.95	1.03	4.93	89	SRD50-057-09-13
	1.53	4.43	80	SRD50-057-14-22

L (m)	L1 (m)	L2 (m)	ET (mm)	Model No.:
5.95	1.53	4.43	97	SRD50-057-14-24
	1.53	4.43	97	SRD50-057-14-44
	2.03	3.93	89	SRD50-057-19-13
	2.53	3.43	80	SRD50-057-24-22
6.05	3.03	3.03	72	SRD50-057-29-11
	3.03	3.03	89	SRD50-057-29-33
	3.03	3.03	106	SRD50-057-29-55
6.35	1.03	5.33	97	SRD50-061-09-14
6.45	1.53	4.93	89	SRD50-062-14-23
	2.03	4.43	80	SRD50-062-19-12
	2.03	4.43	97	SRD50-062-19-14
	2.53	3.93	89	SRD50-062-24-23
	3.03	3.43	80	SRD50-062-29-12
6.85	1.53	5.33	97	SRD50-066-14-24
	1.53	5.33	97	SRD50-066-14-44
	3.43	3.43	80	SRD50-066-33-22
6.95	1.03	5.93	89	SRD50-067-09-13
	1.03	5.93	106	SRD50-067-09-15
	2.03	4.93	89	SRD50-067-19-13
	2.53	4.43	80	SRD50-067-24-22
	2.53	4.43	97	SRD50-067-24-24
	3.03	3.93	89	SRD50-067-29-33
7.35	1.03	6.33	97	SRD50-071-09-14
	2.03	5.33	97	SRD50-071-19-14
	3.43	3.93	89	SRD50-071-33-23
7.45	1.53	5.93	89	SRD50-072-14-23
	1.53	5.93	106	SRD50-072-14-25
	1.53	5.93	97	SRD50-072-14-43
	1.53	5.93	106	SRD50-072-14-45
	2.53	4.93	89	SRD50-072-24-23
	3.03	4.43	80	SRD50-072-29-12
	3.03	4.43	97	SRD50-072-29-14
	3.03	4.43	97	SRD50-072-29-34
7.85	1.03	6.83	106	SRD50-076-09-15
	1.53	6.33	97	SRD50-076-14-24
	1.53	6.33	97	SRD50-076-14-44



Module channel two-sided

L (m)	L1 (m)	L2 (m)	ET (mm)	Model No.:
7.85	2.53	5.33	97	SRD50-076-24-24
	3.43	4.43	80	SRD50-076-33-22
	3.43	4.43	97	SRD50-076-33-24
	3.93	3.93	89	SRD50-076-38-33
7.95	2.03	5.93	89	SRD50-077-19-13
	2.03	5.93	106	SRD50-077-19-15
	3.03	4.93	89	SRD50-077-29-13
	3.03	4.93	89	SRD50-077-29-33
8.35	3.03	4.93	106	SRD50-077-29-53
	1.03	7.33	97	SRD50-081-09-14
	1.53	6.83	106	SRD50-081-14-25
	1.53	6.83	106	SRD50-081-14-45
8.35	2.03	6.33	97	SRD50-081-19-14
	3.03	5.33	97	SRD50-081-29-14
	3.03	5.33	97	SRD50-081-29-34
	3.03	5.33	106	SRD50-081-29-54
	3.43	4.93	89	SRD50-081-33-23
	3.93	4.43	89	SRD50-081-38-32
	3.93	4.43	97	SRD50-081-38-34
	3.93	4.43	97	SRD50-081-38-34
8.45	2.53	5.93	89	SRD50-082-24-23
	2.53	5.93	106	SRD50-082-24-25
8.75	3.43	5.33	97	SRD50-085-33-24
8.85	1.03	7.83	106	SRD50-086-09-15
	1.53	7.33	97	SRD50-086-14-24
	1.53	7.33	97	SRD50-086-14-44
	2.03	6.83	106	SRD50-086-19-15
	2.53	6.33	97	SRD50-086-24-24
	3.93	4.93	89	SRD50-086-38-33
	4.43	4.43	80	SRD50-086-43-22
4.43	4.43	97	SRD50-086-43-44	
8.95	3.03	5.93	89	SRD50-087-29-13
	3.03	5.93	106	SRD50-087-29-15
	3.03	5.93	89	SRD50-087-29-33
	3.03	5.93	106	SRD50-087-29-35
	3.03	5.93	106	SRD50-087-29-55
9.25	3.93	5.33	97	SRD50-090-38-34
9.35	1.53	7.83	106	SRD50-091-14-25
	1.53	7.83	106	SRD50-091-14-45
	2.03	7.33	97	SRD50-091-19-14
	2.53	6.83	106	SRD50-091-24-25
	3.03	6.33	97	SRD50-091-29-14
	3.03	6.33	97	SRD50-091-29-34
	3.43	5.93	89	SRD50-091-33-23
	3.43	5.93	106	SRD50-091-33-25
	4.43	4.93	89	SRD50-091-43-23
	4.43	4.93	97	SRD50-091-43-43
9.75	4.43	5.33	97	SRD50-095-43-24
	4.43	5.33	97	SRD50-095-43-44
9.85	1.03	8.83	106	SRD50-096-09-15
	2.03	7.83	106	SRD50-096-29-15
	2.53	7.33	97	SRD50-096-24-24
	3.03	6.83	106	SRD50-096-29-15

L (m)	L1 (m)	L2 (m)	ET (mm)	Model No.:
9.85	3.03	6.83	106	SRD50-096-29-35
	3.03	6.83	106	SRD50-096-29-55
	3.93	5.93	89	SRD50-096-38-33
	3.93	5.93	106	SRD50-096-38-35
	4.93	4.93	89	SRD50-096-48-33
10.25	3.43	6.83	106	SRD50-100-33-25
	3.93	6.33	97	SRD50-100-38-34
	4.93	5.33	97	SRD50-100-48-34
10.35	1.53	8.83	106	SRD50-101-14-25
	1.53	8.83	106	SRD50-101-14-45
	2.53	7.83	106	SRD50-101-24-25
	3.03	7.33	97	SRD50-101-29-14
	3.03	7.33	97	SRD50-101-29-34
	4.43	5.93	89	SRD50-101-43-23
	4.43	5.93	106	SRD50-101-43-25
10.65	5.33	5.33	97	SRD50-104-52-44
10.75	3.43	7.33	97	SRD50-105-33-24
	3.93	6.83	106	SRD50-105-38-35
	4.43	6.33	97	SRD50-105-43-24
	4.43	6.33	97	SRD50-105-43-44
10.85	2.03	8.83	106	SRD50-106-19-15
	3.03	7.83	106	SRD50-106-29-15
	3.03	7.83	106	SRD50-106-29-35
	3.03	7.83	106	SRD50-106-29-55
	4.93	5.93	89	SRD50-106-48-33
	4.93	5.93	106	SRD50-106-48-35
	3.43	7.83	106	SRD50-110-33-25
11.25	3.93	7.33	97	SRD50-110-38-34
	4.43	6.83	106	SRD50-110-43-25
	4.43	6.83	106	SRD50-110-43-45
	4.93	6.33	97	SRD50-110-48-34
	5.33	5.93	89	SRD50-110-52-43
11.35	5.33	5.93	106	SRD50-110-52-45
	2.53	8.83	106	SRD50-111-24-25
	5.33	6.33	97	SRD50-114-52-44
11.75	3.93	7.83	106	SRD50-115-38-35
	4.43	7.33	97	SRD50-115-43-24
	4.43	7.33	97	SRD50-115-43-44
	4.93	6.83	106	SRD50-115-48-35
11.85	3.03	8.83	106	SRD50-116-29-15
	3.03	8.83	106	SRD50-116-29-35
	3.03	8.83	106	SRD50-116-29-55
	5.93	5.93	89	SRD50-116-58-33
12.15	5.93	5.93	106	SRD50-116-58-55
	5.33	6.83	106	SRD50-119-52-45
	3.43	8.83	106	SRD50-120-33-25
12.25	4.43	7.83	106	SRD50-120-43-25
	4.43	7.83	106	SRD50-120-43-45
	4.93	7.33	97	SRD50-120-48-34
12.65	5.93	6.33	97	SRD50-120-58-34
	5.33	7.33	97	SRD50-124-52-44
	6.33	6.33	97	SRD50-124-62-44

L (m)	L1 (m)	L2 (m)	ET (mm)	Model No.:
12.75	3.93	8.83	106	SRD50-125-38-35
	4.93	7.83	106	SRD50-125-48-35
	5.93	6.83	106	SRD50-125-58-35
	5.93	6.83	106	SRD50-125-58-55
13.15	5.33	7.83	106	SRD50-129-52-45
	6.33	6.83	106	SRD50-129-62-45
13.25	4.43	8.83	106	SRD50-130-43-25
	4.43	8.83	106	SRD50-130-43-45
	5.93	7.33	97	SRD50-130-58-34
13.65	5.93	7.33	106	SRD50-130-58-54
	6.33	7.33	97	SRD50-134-62-44
13.75	6.83	6.83	106	SRD50-134-67-55
	4.93	8.83	106	SRD50-135-48-35
	5.93	7.83	106	SRD50-135-58-35
14.15	5.93	7.83	106	SRD50-135-58-55
	5.33	8.83	106	SRD50-139-52-45
	6.33	7.83	106	SRD50-139-62-45
14.65	6.83	7.33	106	SRD50-139-67-54
	6.83	7.83	106	SRD50-144-67-55
14.75	7.33	7.33	97	SRD50-144-72-44
	5.93	8.83	106	SRD50-145-58-35
15.15	5.93	8.83	106	SRD50-145-58-55
	6.33	8.83	106	SRD50-149-62-45
15.65	7.33	7.83	106	SRD50-149-72-45
	6.83	8.83	106	SRD50-154-67-55
16.15	7.83	7.83	106	SRD50-154-77-55
	7.33	8.83	106	SRD50-159-72-45
16.65	7.83	8.83	106	SRD50-164-77-55
17.65	8.83	8.83	106	SRD50-174-87-55

## Industrial channel SKR-I

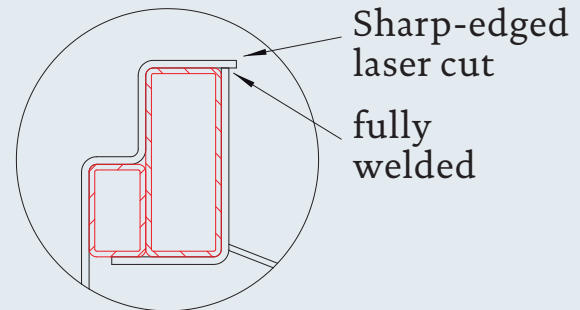
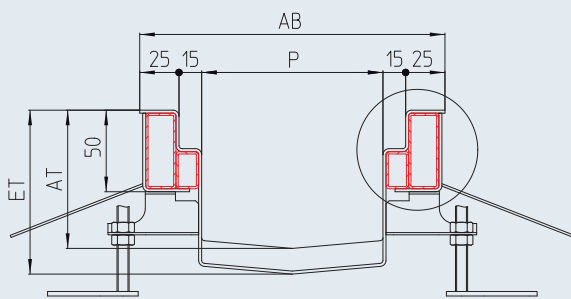
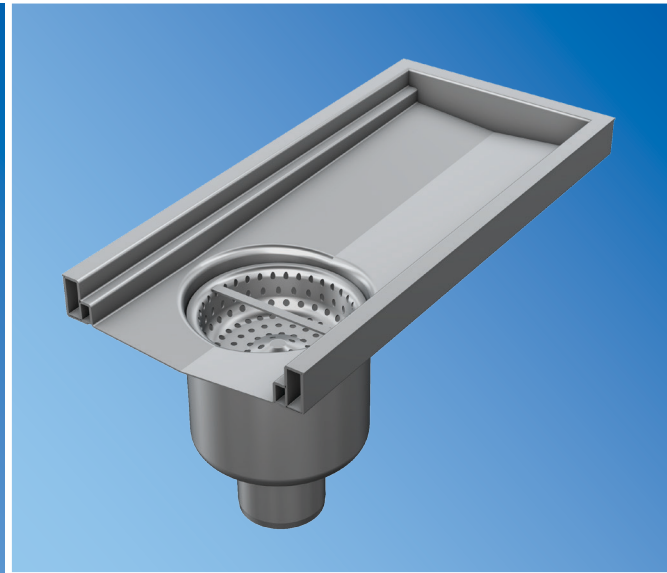
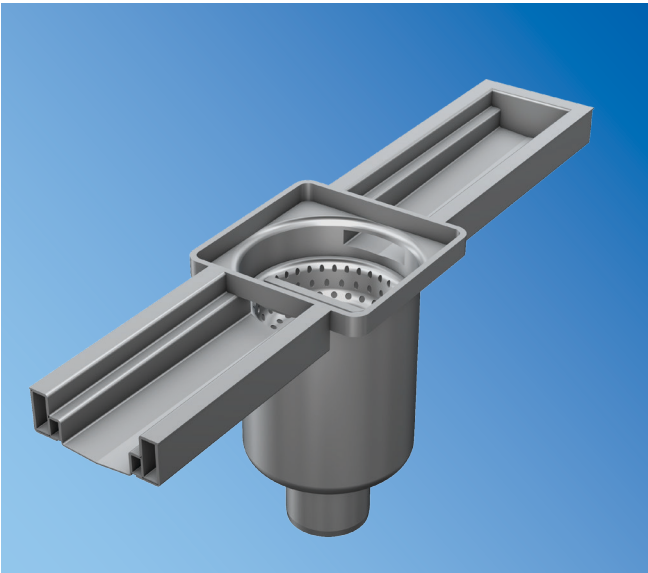

### Floor connection

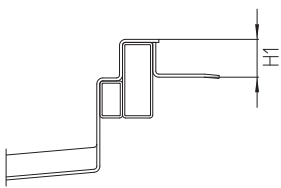

**AF** Attachment flange<sup>11)</sup>

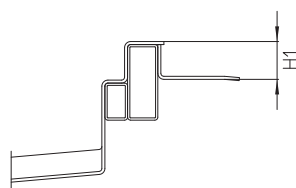

**HF** Bonding flange<sup>11)</sup>

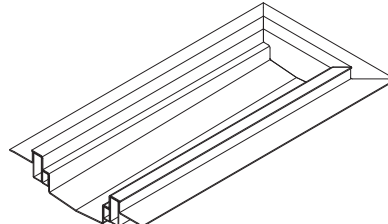
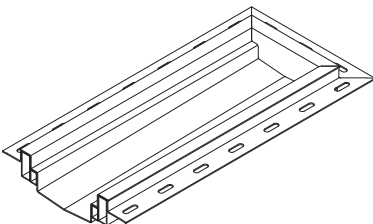

### Description for use in tenders

Industrial channel, Model SKR-I, edge protection and grate edge reinforced on the inside with stainless steel rectangular profiles. Edge extensions as absolutely sharp edged laser cut without bending radius for optimal transition to the adjoining floor or grouting material. The visible edge is fully welded to the vertical side of the supporting angle. With all round wall anchors every 500 mm and U-shaped mounting racks for efficient floor bonding and adjustable height. Plug mounting feet every 1,000 mm. Interior transverse incline and fall 0.6%. Channel in welded, not in flanged design, with welded channel floor drain. Surface grain blasted.

<sup>11)</sup> Wall anchors not required

## Commercial channel SKR-G

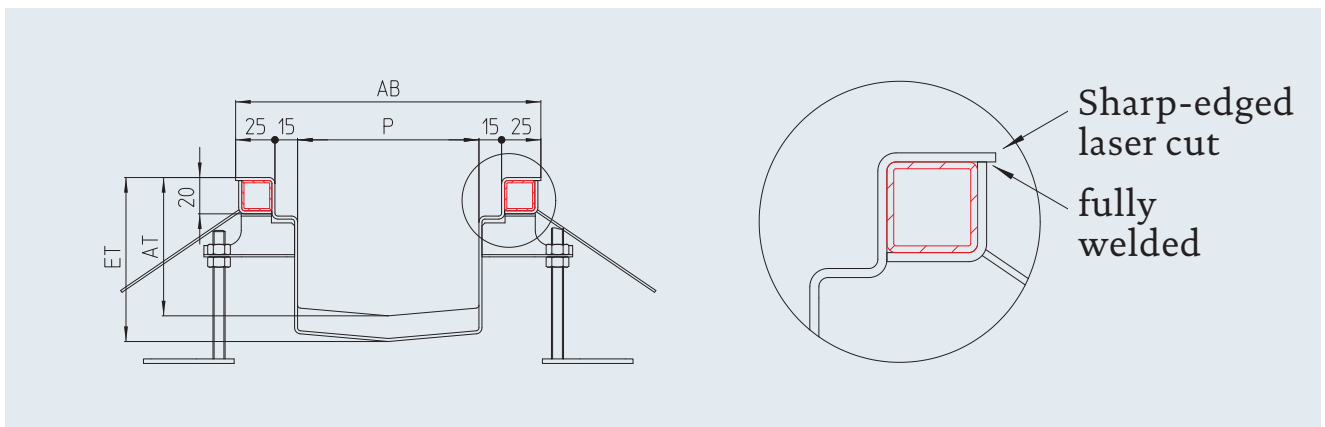
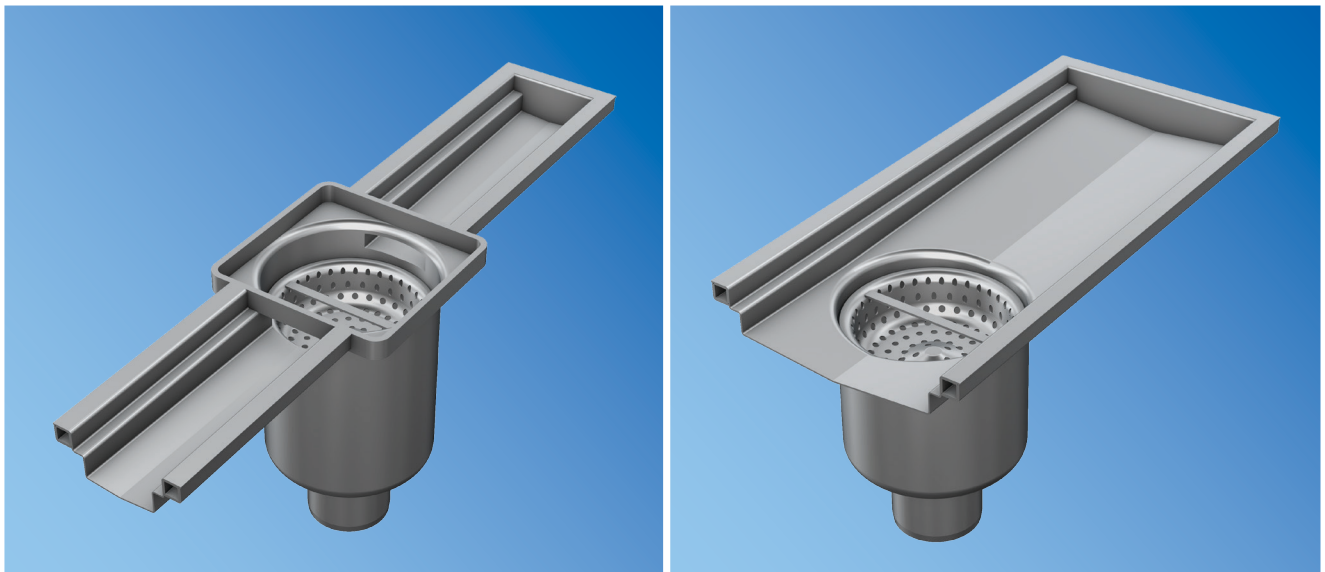

### Floor connection

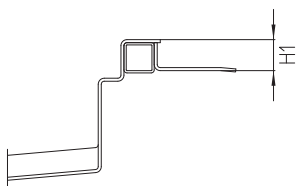

**AF** Attachment flange<sup>1)</sup>

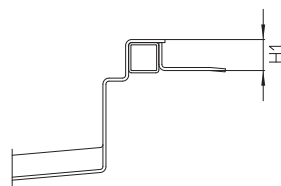

**HF** Bonding flange<sup>1)</sup>

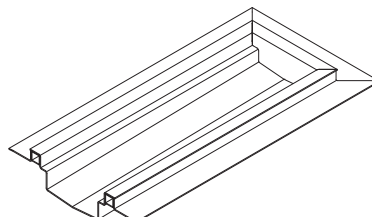
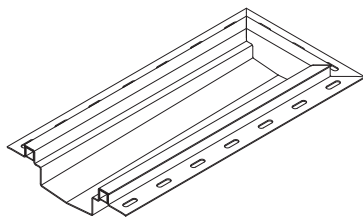

### Description for use in tenders

Commercial channel, Model SKR-G, edge protection reinforced on the inside with stainless steel rectangular profiles. Edge extensions as absolutely sharp edged laser cut without bending radius for optimal transition to the adjoining floor or grouting material. The visible edge is fully welded to the vertical side of the supporting angle. With all round wall anchors every 500 mm and U-shaped mounting racks for efficient floor bonding and adjustable height. Plug mounting feet every 1,000 mm. Interior transverse incline and fall 0.6%. Channel in welded, not in flanged design, with welded channel floor drain. Surface grain blasted.

## Vario channel SVKR

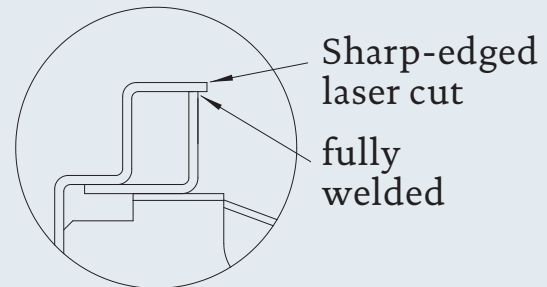
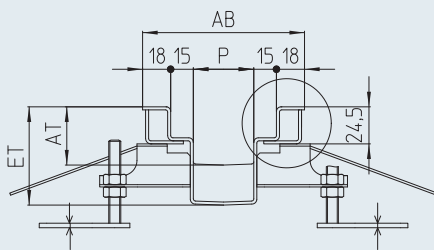
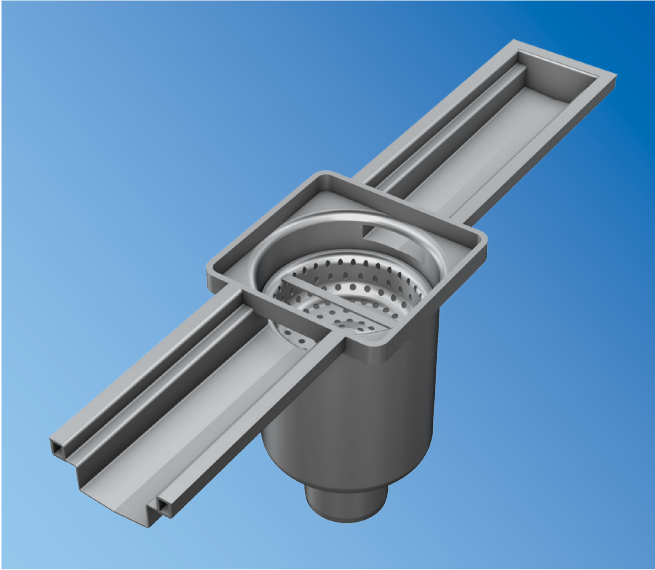

### Floor connection

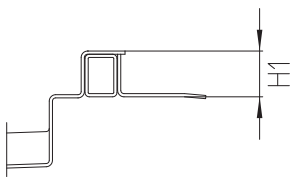

**AF** Attachment flange<sup>11)</sup>

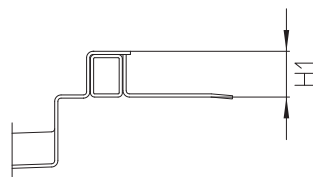

**HF** Bonding flange<sup>11)</sup>

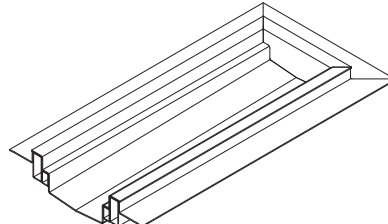
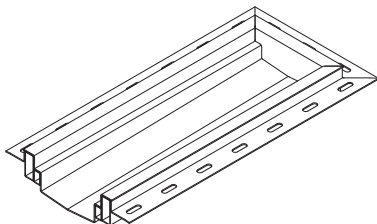

### Description for use in tenders

Vario channel, ModellSVKR. Edge extensions as absolutely sharp edged laser cut without bending radius for optimal transition to the adjoining floor or grouting material. The visible edge is fully welded to the vertical side of the supporting angle. With all round wall anchors every 500 mm and U-shaped mounting racks for efficient floor bonding and adjustable height. Plug mounting feet every 1,000 mm. Interior transverse incline and fall 0.6%. Channel in welded, not in flanged design, with welded channel floor drain. Surface grain blasted.

<sup>11)</sup> Wall anchors not required

## Slot channel SSRD

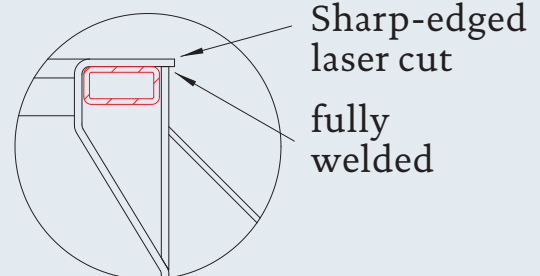
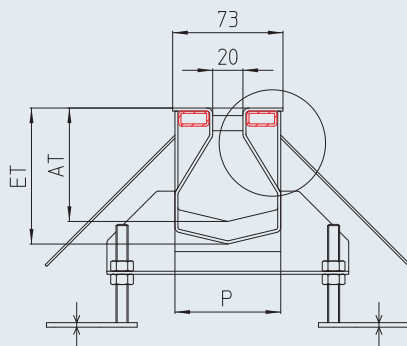
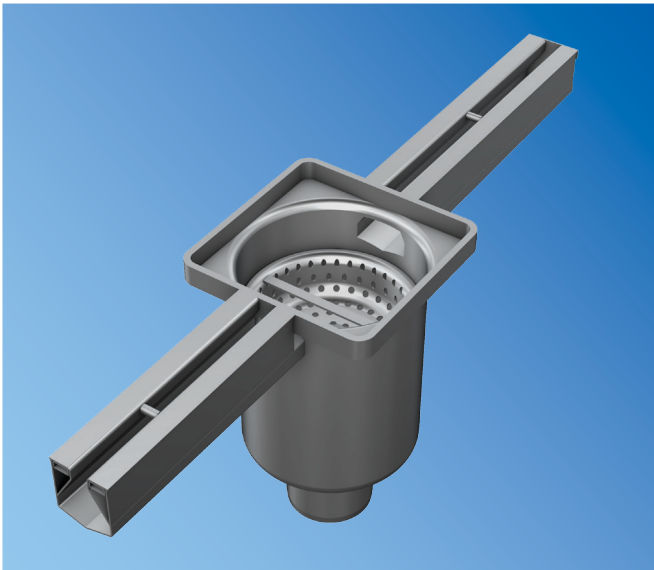

### Floor connection

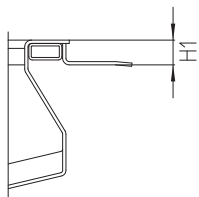

**AF** Attachment flange<sup>1)</sup>

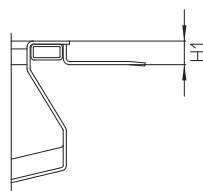

**HF** Bonding flange<sup>1)</sup>

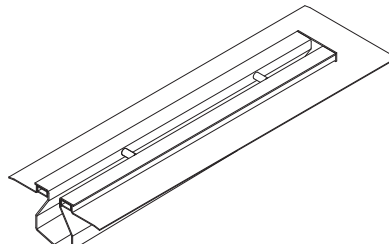
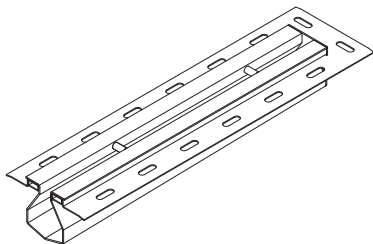

### Description for use in tenders

Slot channel, Model SSRD, edge protection reinforced on the inside with stainless steel rectangular profiles. Edge extensions as absolutely sharp edged laser cut without bending radius for optimal transition to the adjoining floor or grouting material. The visible edge is fully welded to the vertical side of the supporting angle. With all round wall anchors every 500 mm and U-shaped mounting racks for efficient floor bonding and adjustable height. Plug mounting feet every 1,000 mm. Interior transverse incline and fall 0.6%. Channel in welded, not in flanged design, with welded channel floor drain. Surface grain blasted.



## Channel drain RSKE-MIT-S

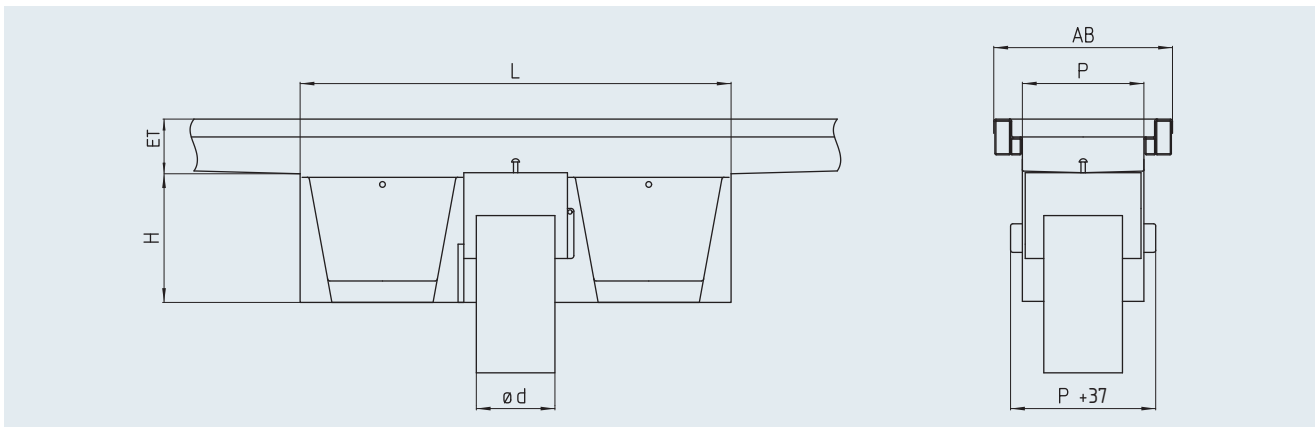
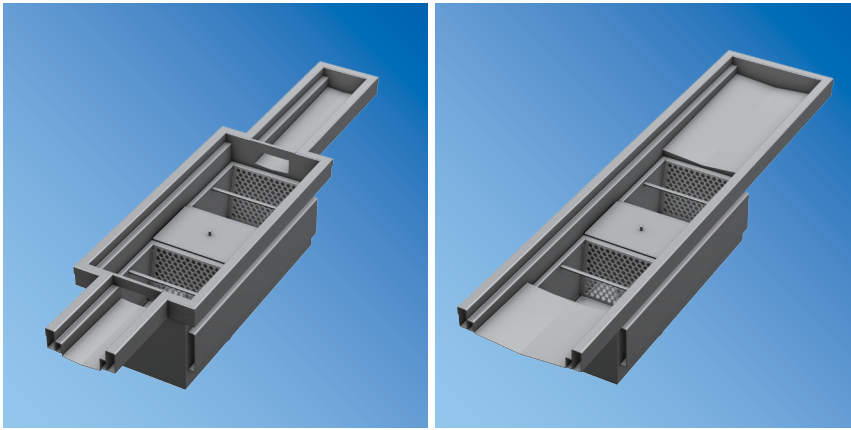

### Channel drain – centred – vertical

Model	Nominal size DN	Ø d [mm]	Profil P [mm]	AB [mm]	L [mm]	H [mm]	Flow rate [l/s]	Silt box volume [l]
RSKE-090-070-MIT-S	70	75	90	170	600	180	> 1.5	2 x 1.8
RSKE-120-070-MIT-S	100	110	120	200	600	180	> 2.8	2 x 2.3
RSKE-120-100-MIT-S	100	110	170	250	600	180	> 2.8	2 x 4.1
RSKE-170-100-MIT-S	150	160	170	250	700	180	> 8.2	2 x 4.1
RSKE-170-150-MIT-S	100	110	220	300	600	180	> 2.8	2 x 5.0
RSKE-220-150-MIT-S	150	160	220	300	800	210	> 8.2	2 x 7.4
RSKE-220-200-MIT-S	200	200	220	300	1000	250	> 12.5	2 x 8.7
RSKE-320-200-MIT-S	150	160	320	400	800	210	> 8.2	2 x 11.3
RSKE-320-250-MIT-S	200	200	320	400	1000	250	> 12.5	2 x 15
RSKE-420-250-MIT-S	250	250	320	400	1000	280	> 20.2	2 x 15
RSKE-420-300-MIT-S	300	315	420	500	1050	280	> 29.8	2 x 19.7

### Description for use in tenders

Channel drain, single-part, Model RSKE, according to EN 1253, centrally welded in the channel. With liftable air trap and two large stainless steel silt boxes. Edge protection reinforced with an internally mounted, welded rectangular profile and channel edge. Floor connection as channel, vertical runoff support. Surface grain blasted.

Nominal width:	• DN 70	• DN 100	• DN 150	• DN 200	• DN 250	• DN 300
Grade:	• 1.4301 [AISI 304]		• 1.4571 [AISI 316 Ti] <sup>®</sup>			
Cover:	• Plate cover, M125 • Grating MW25 Support rod 25/2RH		• Bar grate, M125 • Grating MW25 Support rod 25/3RH		• Plate cover, 3 mm, K3 • Grating MW25 Support rod 25/4RH	
Opt. Air trap:	• Plug-in bell air trap		• Removable standpipe with bell air trap		• Welded standpipe lockable using a spindle	

We will be pleased to provide a description for specific objects for use in tenders.



## Channel drain RSKE-END-S

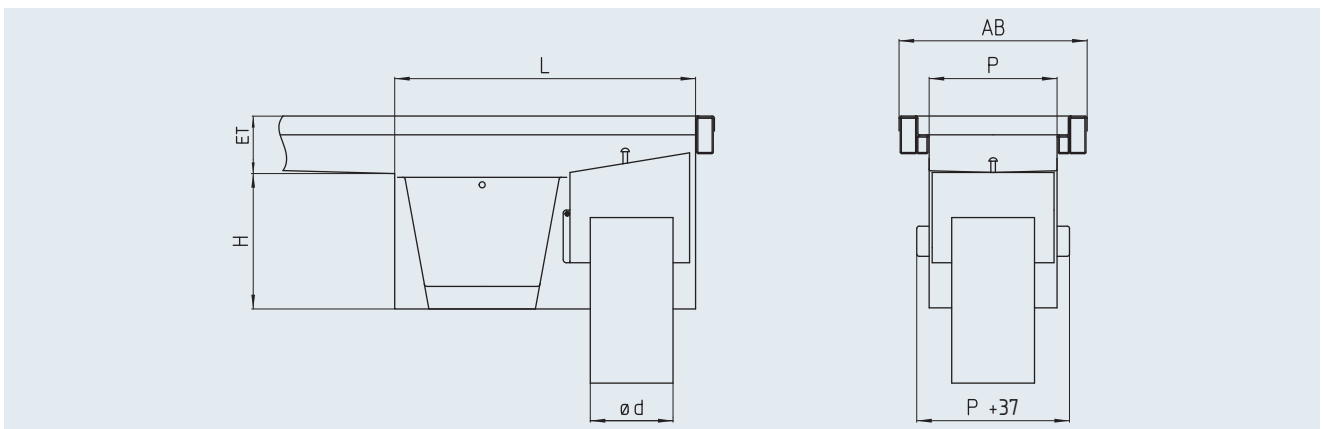
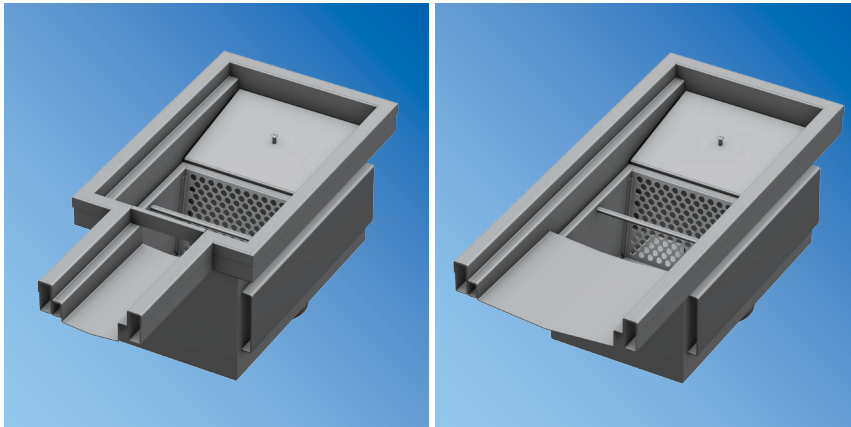

### Channel drain – end – vertical

Model	Nominal size DN	Ø d [mm]	Profil P [mm]	AB [mm]	L [mm]	H [mm]	Flow rate [l/s]	Silt box volume [l]
RSKE-090-070-END-S	70	75	90	170	400	180	> 1.5	1.8
RSKE-120-070-END-S	100	110	120	200	400	180	> 2.8	2.3
RSKE-120-100-END-S	100	110	170	250	400	180	> 2.8	4.1
RSKE-170-100-END-S	150	160	170	250	550	210	> 8.2	4.1
RSKE-170-150-END-S	100	110	220	300	400	180	> 2.8	5.0
RSKE-220-150-END-S	150	160	220	300	550	210	> 8.2	7.4
RSKE-220-200-END-S	200	200	220	300	650	250	> 12.5	8.7
RSKE-320-200-END-S	150	160	320	400	550	210	> 8.2	11.3
RSKE-320-250-END-S	200	200	320	400	600	250	> 12.5	15.0
RSKE-420-250-END-S	250	250	320	400	650	280	> 20.2	15.0
RSKE-420-300-END-S	300	315	420	500	on request			

### Description for use in tenders

Channel drain, single-part, Model RSKE, according to EN 1253, welded at the end of the channel. With liftable air trap and two large stainless steel silt boxes. Edge protection reinforced with a internally mounted, welded rectangular profile and channel edge. Floor connection as channel, vertical runoff support. Surface grain blasted.

Nominal width:	• DN 70	• DN 100	• DN 150	• DN 200	• DN 250	• DN 300
Grade:	• 1.4301 [AISI 304]		• 1.4571 [AISI 316 Ti] <sup>8)</sup>			
Cover:	• Plate cover, M125 • Grating MW25 Support rod 25/2RH		• Bar grate, M125 • Grating MW25 Support rod 25/3RH		• Plate cover, 3 mm, K3 • Grating MW25 Support rod 25/4RH	
Opt. Air trap:	• Plug-in bell air trap		• Removable standpipe with bell air trap		• Welded standpipe lockable using a spindle	

We will be pleased to provide a description for specific objects for use in tenders.

## Channel drain RSKE-MIT-W

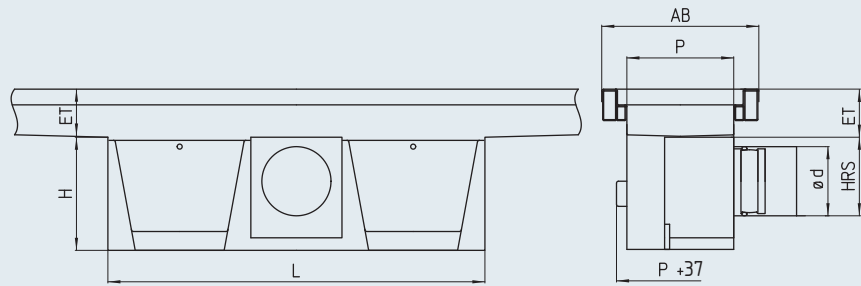
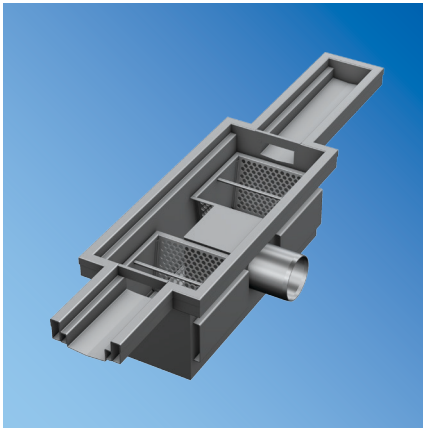

### Channel drain - centred - horizontal

Model	Nenngröße DN	Ø d [mm]	Profil P [mm]	AB [mm]	L [mm]	H [mm]	HRS [mm]	Flow rate [l/s]	Silt box vol.[l]
RSKE-170-100-MIT-W	100	110	170	250	600	180	125	> 2.8	2 x 4.1
RSKE-170-150-MIT-W	150	160	170	250	700	210	150	> 8.2	2 x 4.1
RSKE-220-100-MIT-W	100	110	220	300	600	180	125	> 2.8	2 x 4.8
RSKE-220-150-MIT-W	150	160	220	300	800	210	170	> 8.2	2 x 7.4
RSKE-220-200-MIT-W	200	200	220	300	1000	250	225	> 12.5	2 x 8.7
RSKE-320-150-MIT-W	150	160	320	400	800	210	170	> 8.2	2 x 11.4
RSKE-420-200-MIT-W	200	200	420	500	1000	250	200	> 12.5	2 x 15.0
RSKE-420-250-MIT-W	250	250	420	500				on request	
RSKE-420-300-MIT-W	300	315	420	500				on request	

### Description for use in tenders

Channel drain, single-part, Model RSKE, according to EN 1253, welded at the end of the channel. With plug-in air trap and a large stainless steel silt box. Edge protection reinforced with a internally mounted, welded rectangular profile and channel edge. Floor connection as channel. Horizontal runoff support. Surface grain blasted.

Nominal width:	• DN 70	• DN 100	• DN 150	• DN 200	• DN 250	• DN 300
Grade:	• 1.4301 [AISI 304]		• 1.4571 [AISI 316 Ti] <sup>®</sup>			
Cover:	• Plate cover, M125 • Grating MW25 Support rod 25/2RH	• Bar grate, M125 • Grating MW25 Support rod 25/3RH		• Plate cover, 3 mm, K3 • Grating MW25 Support rod 25/4RH		

We will be pleased to provide a description for specific objects for use in tenders.

## Channel drain RSKE-MIT-W

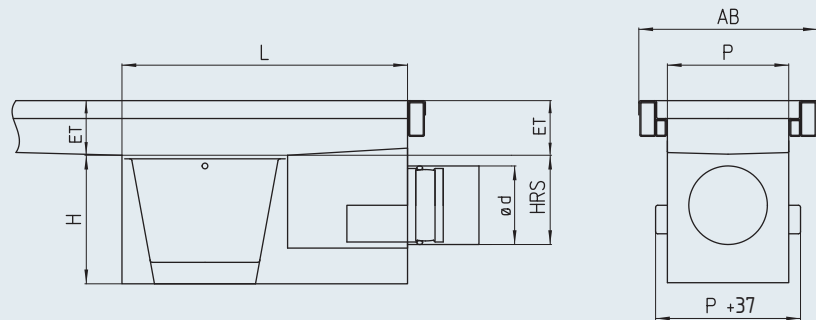
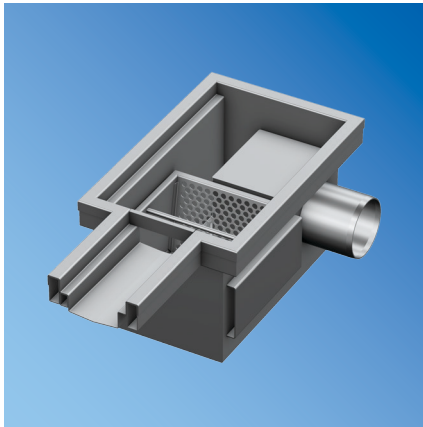

### Channel drain – end – horizontal

Model	Nominal size DN	Ø d [mm]	Profil P [mm]	AB [mm]	L [mm]	H [mm]	HRS [mm]	Flow rate [l/s]	Silt box vol.[l]
RSKE-090-070-END-W <sup>16)</sup>	70	75	90	170	400	180	108	> 1.5	1.8
RSKE-120-070-END-W <sup>16)</sup>	70	75	120	200	400	180	108	> 1.5	2.3
RSKE-120-100-END-W <sup>16)</sup>	100	110	120	200	400	180	108	> 2.8	2.3
RSKE-170-070-END-W	70	75	170	250	400	180	108	> 1.5	4.1
RSKE-170-100-END-W	100	110	170	250	400	180	125	> 2.8	4.1
RSKE-170-150-END-W	150	160	170	250	550	250	160	> 8.2	5.5
RSKE-220-100-END-W	100	110	220	300	400	180	125	> 2.8	4.8
RSKE-220-150-END-W	150	160	220	300	550	210	150	> 8.2	7.4
RSKE-220-200-END-W	200	200	220	300	600	320	220	> 12.5	8.7
RSKE-320-150-END-W	150	160	320	400	550	210	150	> 8.2	11.4
RSKE-320-200-END-W	200	200	320	400	600	300	210	> 12.5	15
RSKE-320-250-END-W	250	250	320	400	650	350	265	> 20.2	15
RSKE-420-200-END-W	200	200	420	500	on request				
RSKE-420-250-END-W	250	250	420	500	on request				
RSKE-420-300-END-W	300	315	420	500	on request				

### Description for use in tenders

Channel drain, single-part, Model RSKE, according to EN 1253, centrally welded in the channel. With plug-in air trap and two large stainless steel silt boxes. Edge protection reinforced with an internally mounted, welded rectangular profile and channel edge. Floor connection as channel. Horizontal runoff support. Surface grain blasted.

Nominal width:	• DN 70	• DN 100	• DN 150	• DN 200	• DN 250	• DN 300
Grade:	• 1.4301 [AISI 304]		• 1.4571 [AISI 316 Ti] <sup>®)</sup>			
Cover:	• Plate cover, M125 • Grating MW25 Support rod 25/2RH		• Bar grate, M125 • Grating MW25 Support rod 25/3RH		• Plate cover, 3 mm, K3 • Grating MW25 Support rod 25/4RH	

We will be pleased to provide a description for specific objects for use in tenders.

<sup>16)</sup> Only with frontal discharge direction

## Channel drain RSKH-MIT-S

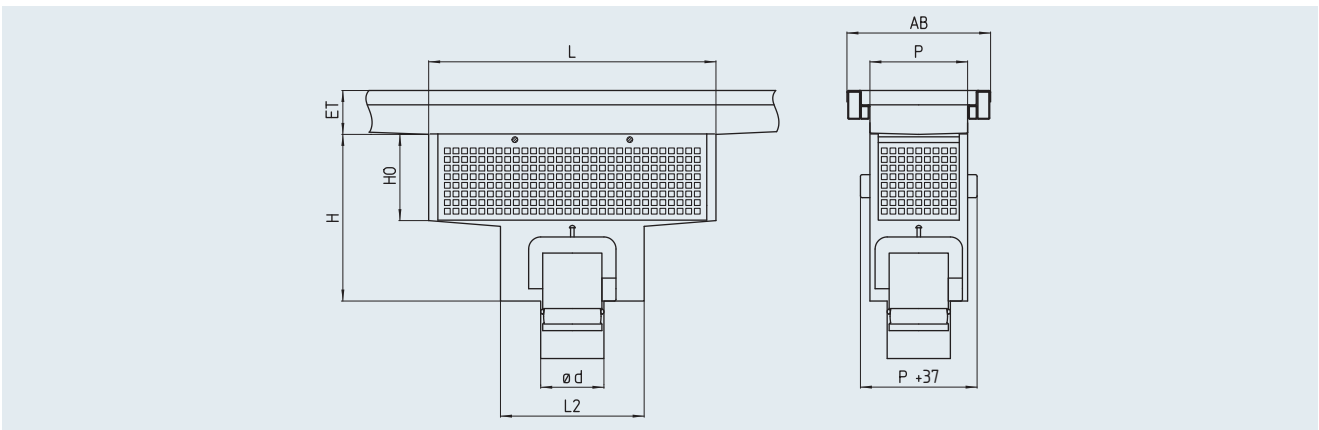
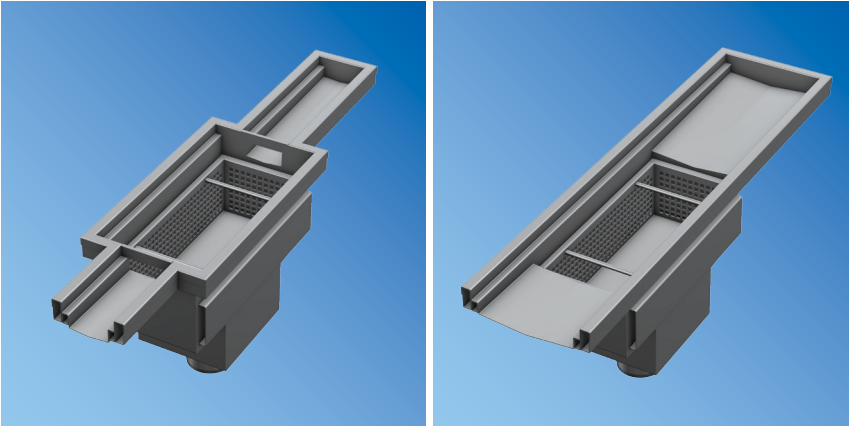

### Channel drain – centred – vertical

Model	Nominal size DN	Ø d [mm]	Profil P [mm]	AB [mm]	L [mm]	L2 [mm]	H [mm]	HO [mm]	Flow rate [l/s]	Silt box vol. [l]
RSKH-090-070-MIT-S	70	75	90	170	400	200	290	150	> 1.5	3.0
RSKH-120-070-MIT-S	70	75	120	200	400	200	290	150	> 1.5	4.5
RSKH-170-100-MIT-S	100	110	170	250	500	250	290	150	> 2.8	9.1
RSKH-220-100-MIT-S	100	110	220	300	600	330	350	180	> 2.8	18.3
RSKH-220-150-MIT-S	150	160	220	300	600	330	350	180	> 8.2	18.3
RSKH-320-150-MIT-S	150	160	320	400	600	330	350	180	> 8.2	28.1
RSKH-320-200-MIT-S	200	200	320	400	600	330	360	180	> 12.5	28.1
RSKH-420-200-MIT-S	200	200	420	500	700	330	360	180	> 12.5	44.6
RSKH-420-250-MIT-S	250	250	420	500	700	430	360	180	> 20.2	44.6

### Description for use in tenders

Channel drain, single-part., Model RSKH, according to EN 1253, welded at the end of the channel. With plug-in air trap and a large stainless steel silt box that overlies the water steel. Drain with gradients to the discharge. Edge protection reinforced with an internally mounted, welded rectangular profile and channel edge. Floor connection as channel. Vertical runoff support. Surface grain blasted.

Nominal width:	• DN 70	• DN 100	• DN 150	• DN 200	• DN 250
Grade:	• 1.4301 [AISI 304]		• 1.4571 [AISI 316 Ti] <sup>®</sup>		
Cover:	• Plate cover, M125 • Grating MW25 Support rod 25/2RH		• Bar grate, M125 • Grating MW25 Support rod 25/3RH		• Plate cover, 3 mm, K3 • Grating MW25 Support rod 25/4RH

We will be pleased to provide a description for specific objects for use in tenders.

## Channel drain RSKH-MIT-S

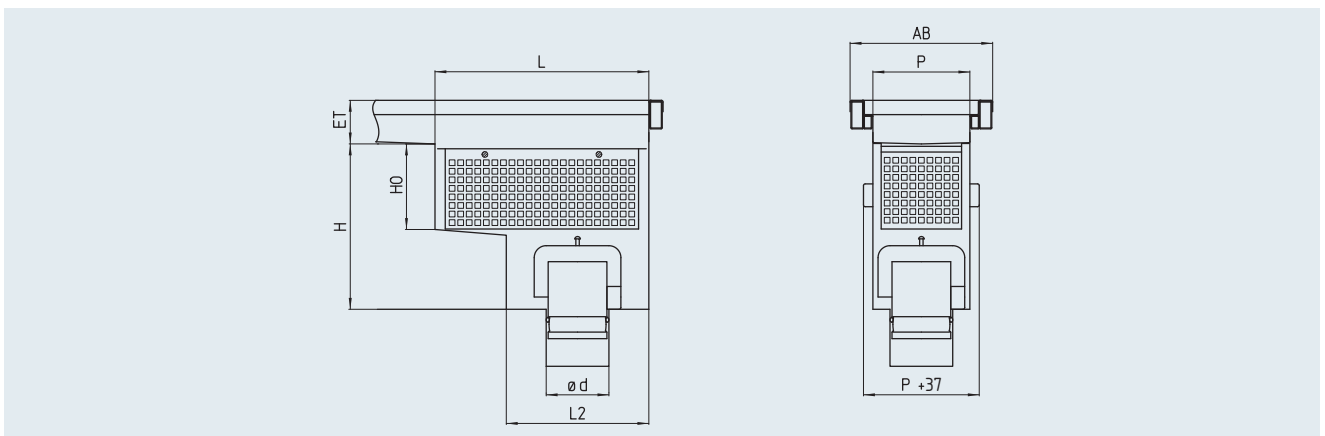
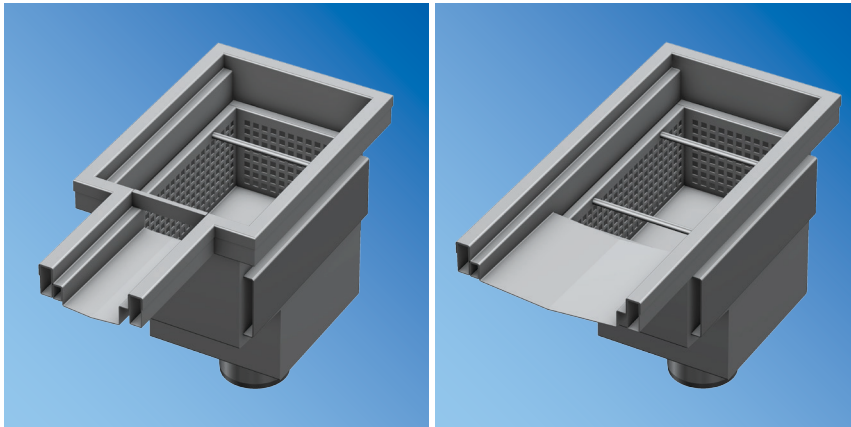

### Channel drain – end – vertical

Model	Nominal size DN	Ø d [mm]	Profil P [mm]	AB [mm]	L [mm]	L2 [mm]	H [mm]	HO [mm]	Flow rate [l/s]	Silt box vol. [l]
RSKH-090-070-END-S	70	75	90	170	300	200	290	150	> 1.5	2.2
RSKH-120-070-END-S	70	75	120	200	300	200	290	150	> 1.5	3.2
RSKH-170-100-END-S	100	110	170	250	375	250	290	150	> 2.8	6.7
RSKH-220-100-END-S	100	110	220	300	465	330	350	180	> 2.8	7.5
RSKH-220-150-END-S	150	160	220	300	465	330	350	180	> 8.2	7.5
RSKH-320-150-END-S	150	160	320	400	450	330	350	180	> 8.2	22.2
RSKH-320-200-END-S	200	200	320	400	450	330	360	180	> 12.5	22.2
RSKH-420-200-END-S	200	200	420	500	450	330	360	180	> 12.5	29.9
RSKH-420-250-END-S	250	250	420	500	550	430	390	180	> 20.2	36.9

### Description for use in tenders

Channel drain, single-part, Model RSKH, according to EN 1253, welded in the channel. With plug-in air trap and a large stainless steel silt box that overlies the water steel. Drain base with gradients to the discharge. Edge protection reinforced with an internally mounted, welded rectangular profile and channel edge. Floor connection as channel. Vertical runoff support. Surface grain blasted.

Nominal width:	• DN 70	• DN 100	• DN 150	• DN 200	• DN 250
Grade:	• 1.4301 [AISI 304]		• 1.4571 [AISI 316 Ti] <sup>®</sup>		
Cover:	• Plate cover, M125 • Grating MW25 Support rod 25/2RH	• Bar grate, M125 • Grating MW25 Support rod 25/3RH		• Plate cover, 3 mm, K3 • Grating MW25 Support rod 25/4RH	

We will be pleased to provide a description for specific objects for use in tenders.



## Large-Cork-Glass-Label drain GKSE-MIT-S

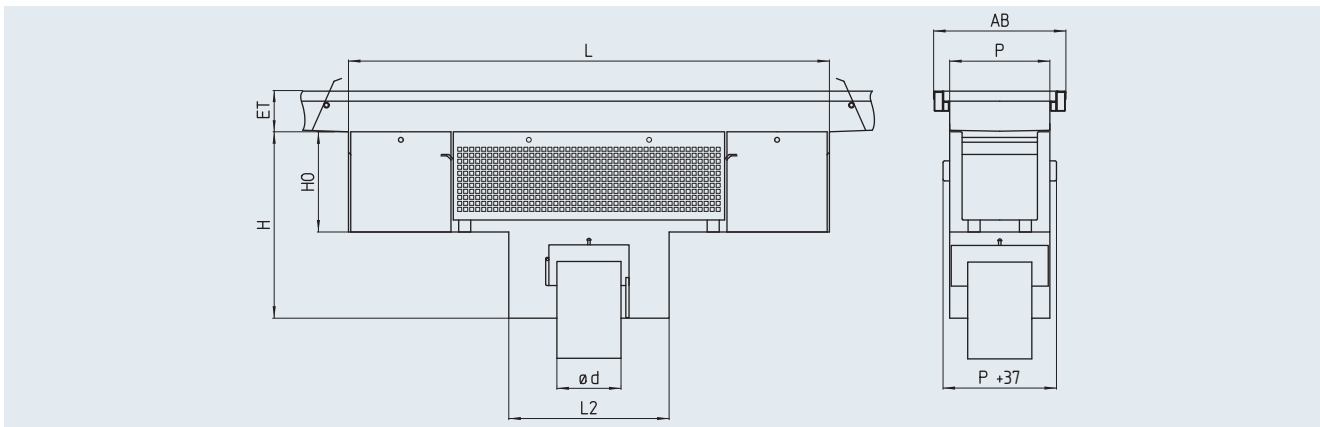
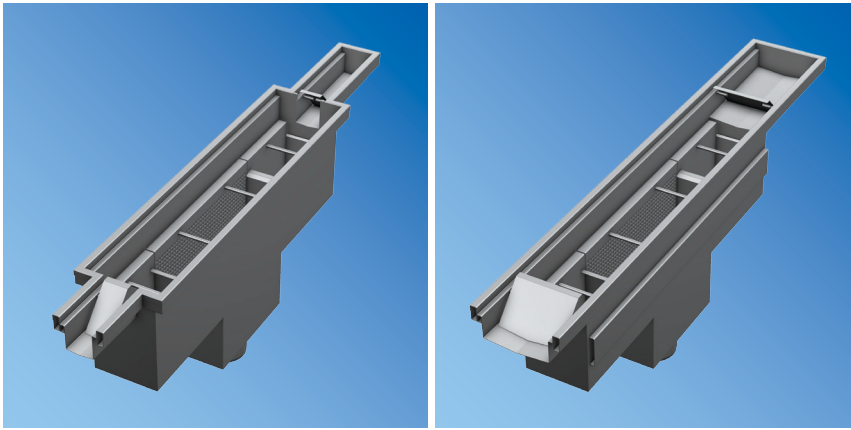

### Large-Cork-Glass-Label drain - centred - vertical

Model	Nominal size DN	$\varnothing d$ [mm]	Profil P [mm]	AB [mm]	L [mm]	L2 [mm]	H [mm]	HO [mm]	Flow rate [l/s]	Label trap vol. [l]	Glass trap vol. [l]
GKSE-220-100-MIT-S	100	110	220	300	1200	400	465	250	> 2.8	17.8	2 x 9.7
GKSE-220-150-MIT-S	150	160	220	300	1200	400	465	250	> 8.2	17.8	2 x 9.7
GKSE-320-100-MIT-S	100	110	320	400	1200	450	535	300	> 2.8	35.3	2 x 18.9
GKSE-320-150-MIT-S	150	160	320	400	1200	450	535	300	> 8.2	35.3	2 x 18.9
GKSE-320-200-MIT-S	200	200	320	400	1200	450	535	300	> 12.5	35.3	2 x 18.9
GKSE-420-250-MIT-S	250	250	420	500	1400	600	560	300	> 20.2	57.4	2 x 30.9
GKSE-420-300-MIT-S	300	315	420	500	1400	600	560	300	> 29.8	57.4	2 x 30.9

### Description for use in tenders

Large-Cork-Glass-Label drain, single-part, Model GKSE, according to EN 1253, welded at the end of the channel. With a foldable air trap, a large glass trap and a stainless steel trap for corks and labels. A shut-off flap on the channel inlet prevents large pieces slipping in when the baskets are removed. Edge protection reinforced with an internally mounted, welded rectangular profile and channel edge. Floor connection as channel. Vertical runoff support. Surface grain blasted.

Nominal width:	• DN 100	• DN 150	• DN 200	• DN 250	• DN 300
Grade:	• 1.4301 [AISI 304]		• 1.4571 [AISI 316 Ti] <sup>1)</sup>		
Cover:	• Plate cover, M125 • Grating MW25 Support rod 25/2RH		• Bar grate, M125 • Grating MW25 Support rod 25/3RH		• Plate cover, 3 mm, K3 • Grating MW25 Support rod 25/4RH
Air trap:	• Plug-in bell air trap		• Removable standpipe with bell air trap		• Welded standpipe lockable using a spindle

Opt.

We will be pleased to provide a description for specific objects for use in tenders.

## Large-Cork-Glass-Label drain GKSE-MIT-S

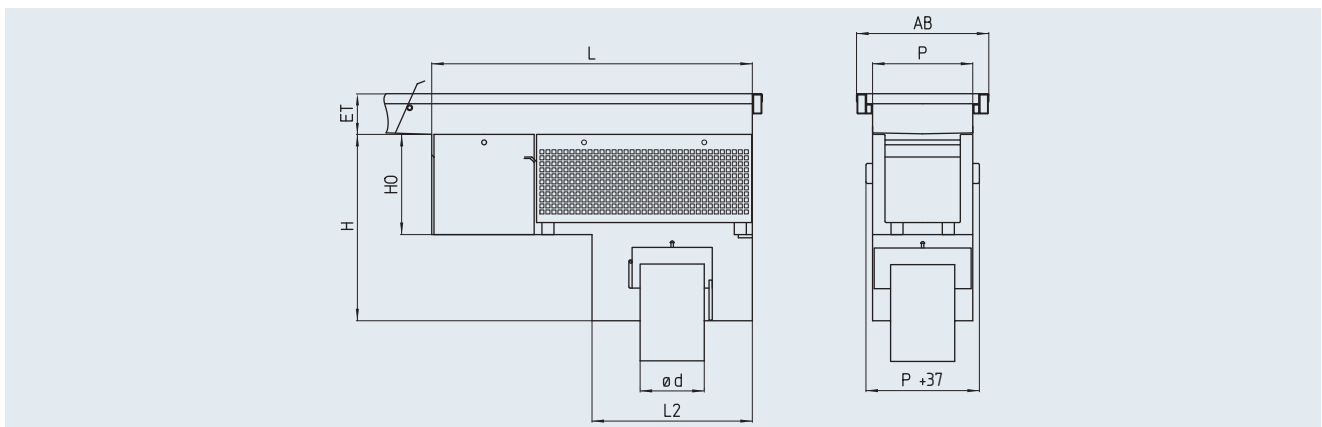
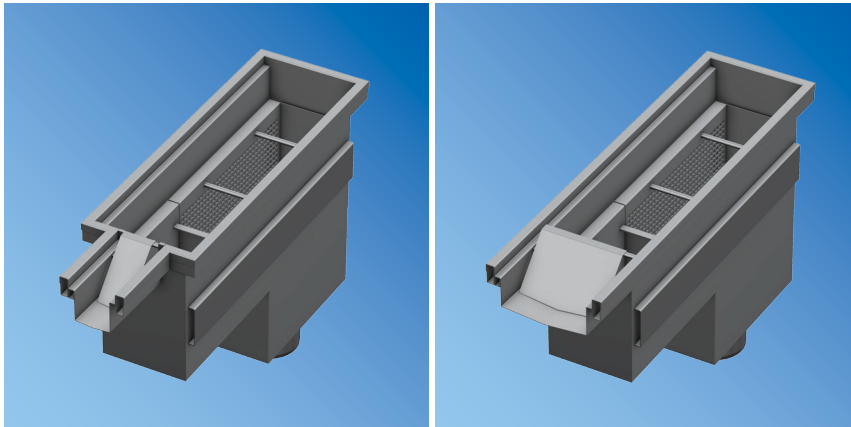

### Large-Cork-Glass-Label drain - end - vertical

Model	Nominal siz DN	Ø d [mm]	Profil P [mm]	AB [mm]	L [mm]	L2 [mm]	H [mm]	HO [mm]	Flow rate [l/s]	Label trap vol. [l]	Glass trap vol. [l]
GKSE-220-100-END-S	100	110	220	300	765	400	465	250	> 2.8	12.5	9.7
GKSE-220-150-END-S	150	160	220	300	765	400	465	250	> 8.2	12.5	9.7
GKSE-320-100-END-S	100	110	320	400	825	450	535	300	> 2.8	29.6	18.9
GKSE-320-150-END-S	150	160	320	400	825	450	535	300	> 8.2	29.6	18.9
GKSE-320-200-END-S	200	200	320	400	825	450	535	300	> 12.5	29.6	18.9
GKSE-420-250-END-S	250	250	420	500	1000	600	560	300	> 20.2	51.7	30.9
GKSE-420-300-END-S	300	315	420	500	1000	600	560	300	> 29.8	51.7	30.9

### Description for use in tenders

Large-Cork-Glass-Label drain, single-part, Model GKSE, according to EN 1253, centrally welded in the channel. With a foldable stench trap, two large glass traps and a centred stainless steel trap basket for corks and labels. Shut-off flaps on the channel inlets prevent large pieces slipping in when the baskets are removed. Edge protection reinforced with an internally mounted, welded rectangular profile and channel edge. Floor connection as channel. Vertical runoff support. Surface grain blasted.

Nominal width: • DN 100 • DN 150 • DN 200 • DN 250 • DN 300

Grade: • 1.4301 [AISI 304] • 1.4571 [AISI 316 Ti]<sup>1)</sup>

Cover: • Plate cover, M125 • Grating MW25 Support rod 25/2RH • Bar grate, M125 • Grating MW25 Support rod 25/3RH • Plate cover, 3 mm, K3 • Grating MW25 Support rod 25/4RH

Opt. Air trap: • Plug-in bell air trap • Removable standpipe with bell air trap • Welded standpipe lockable using a spindle trap

We will be pleased to provide a description for specific objects for use in tenders.

# Industrial floor basin BOWA

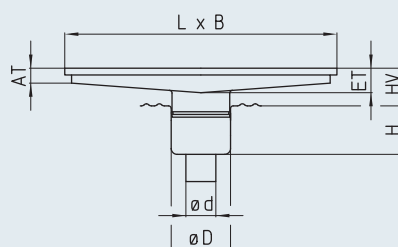
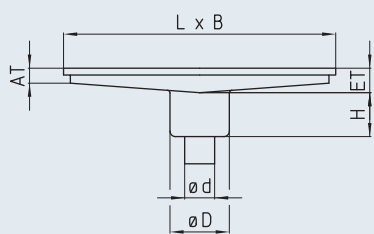
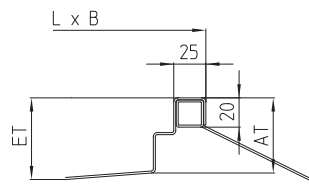
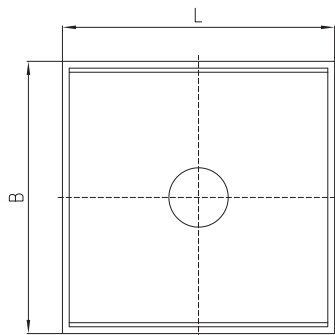

## Cover variants<sup>2)</sup>

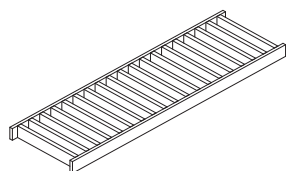

■ Bar grate cover M125

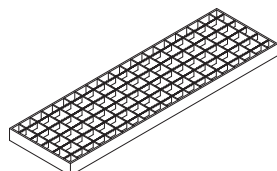

■ Grating cover L15

## Floor connection (optional)

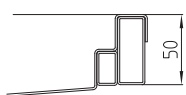

■ Reinforced edge profile

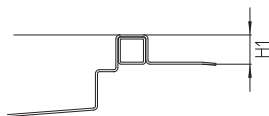

**AF** Attachment flange<sup>11)</sup>  
**HF** Bonding flange<sup>11)</sup>

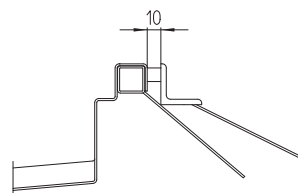

**FAWI** Tile connection angle

## Grade

- 1.4301 (AISI 304)
- 1.4571 (AISI 316 Ti)<sup>1)</sup>





Floor pans				Channel drain								
	L x B	AT	ET	single-part				two-part				
				RBE	Ø d	Ø D	H	RBE	ød	øD	H	HV
BOWA-0400-0400	400 x 400	50	52	DRS-100-S-ROD75	75	218	195	H-100-S-ROD75	75	218	178	70-100
				DRS-100-S	110	218	195	H-100-S	110	218	178	
BOWA-0400-0600	600 x 400	50	52	DRS-100-S-ROD75	75	218	195	H-100-S-ROD75	75	218	178	70-100
				DRS-100-S	110	218	195	H-100-S	110	218	178	
BOWA-0400-0800	800 x 400	50	52	DRS-100-S-ROD75	75	218	195	H-100-S-ROD75	75	218	178	70-100
				DRS-100-S	110	218	195	H-100-S	110	218	178	
BOWA-0600-0600	600 x 600	55	90	DRS-100-S-ROD75	75	218	195	H-100-S-ROD75	75	218	178	70-105
				DRS-100-S	110	218	195	H-100-S	110	218	178	
				DRS-100-S-ROD75	75	218	195	H-100-S-ROD75	75	218	178	
BOWA-0800-0800	800 x 800	55	90	DRS-100-S	110	218	195	H-100-S	110	218	178	70-105
				DRS-100-S-ROD75	75	218	195	H-100-S-ROD75	75	218	178	
				DRS-100-S	110	218	195	H-100-S	110	218	178	
BOWA-1000-1000	1000 x 1000	55	90	DRS-150-S	160	283	235	H-150-S	160	283	209	70-105
				DRS-100-S-ROD75	75	218	195	H-100-S-ROD75	75	218	178	
				DRS-100-S	110	218	195	H-100-S	110	218	178	
BOWA-1200-1200	1200 x 1200	55	90	DRS-150-S	160	283	235	H-150-S	160	283	209	70-105
				DRS-100-S	110	218	195	H-100-S	110	218	178	
				DRS-150-S	160	283	235	H-150-S	160	283	209	

Other sizes available on request.

### Description for use in tenders

Industrial floor basin, edge protection reinforced with a continuous rectangular stainless steel profile. Surrounded with at least 4 wall anchors and U-shaped assembly supports for force-fit floor connection and at least 4 adjustable height installation feet. Inside cross and longitudinal gradients. Pan welded, not flanged, with underwelded or plug-in floor intake. From 800 mm width as standard with two traverses. Surface grain blasted.

Dimension:	L = ..... mm	B = ..... mm		
Grade:	• 1.4301 [AISI 304]	• 1.4571 [AISI 316 Ti] <sup>*)</sup>		
Cover:	• Bar grate, M125	• Grating MW25 Support rod 25/2RH	• Grating MW25 Support rod 25/3RH	• Grating MW25 Support rod 25/4RH
Edge protection:	• Reinforced edge profile			
Opt. Inlet rim:	• Attachment flange		• Tile connection angle 30 x 30, perforated	
	• Bonding flange		• Tile connection angle 30 x 30, unperforated	
<b>Channel drain</b> (for a description, please see the Floor Drains catalogue)				
Model:	• RBE DRS ...	• RBE H ...		
Nominal width:	• DN 70	• DN 100	• DN 150	
Outlet:	• vertical	• horizontal (on request)		

We will be pleased to provide a description for specific objects for use in tenders.

\*) As standard from BOWA-0600-0600 (not with BOWA-0400-0400 / 0400-0600 / 0400-0800)

<sup>1)</sup> If grade 1.4571 is used (AISI 316Ti) some components may be made of grade 1.4404 (AISI 316) for construction reasons <sup>2)</sup> For other covers and explanations see the page on cover variants

<sup>11)</sup> Wall anchors not needed

# Hygiene walkthrough basin DDSB

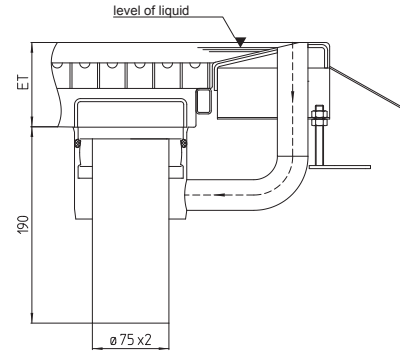
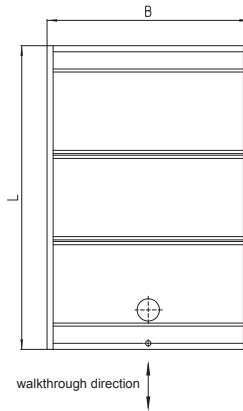

## Cover variants<sup>2)</sup>

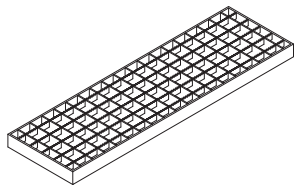

■ Grating cover L15

## Floor connection (optional)

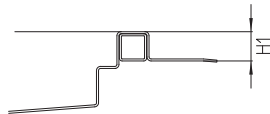

**AF** Attachment flange<sup>11)</sup>  
**HF** Bonding flange<sup>11)</sup>

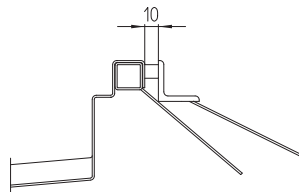

**FAWI** Tile connection angle

## Grade

- 1.4301 (AISI 304)    ■ 1.4571 (AISI 316 Ti)<sup>1)</sup>

## Description for use in tenders

Hygiene walkthrough basin, with suitable entry and exit surfaces in walkthrough direction, with continuous grate, additional traverses for reinforcement in transverse direction. The edge of the bath is reinforced by a continuous profile on the inside. Adjustable height installation feet and wall anchors all round. Grating cover, anti-slip, 15 mm fluid covering. With vertical runoff support DN 70 and suitable stopper which can be removed for emptying residue. A separate overflow is welded. Grade 1.4571 (AISI 316 Ti), Surface grain blasted.

Dimension:	L = ..... mm	B = ..... mm
Grade:	• 1.4301 [AISI 304]	• 1.4571 [AISI 316 Ti] <sup>8)</sup>
Cover:	• Grating MW25 Support rod 25/2RH	• Grating MW25 Support rod 25/3RH      • Grating MW25 Support rod 25/4RH
Opt. Inlet rim:	• Attachment flange • Bonding flange	• Tile connection angle 30 x 30, perforated • Tile connection angle 30 x 30, unperforated

We will be pleased to provide a description for specific objects for use in tenders.

<sup>1)</sup> If grade 1.4571 is used (AISI 316Ti) some components may be made of grade 1.4404 (AISI 316) for construction reasons <sup>2)</sup> For other covers and explanations see the page on cover variants <sup>11)</sup> Wall anchors not needed

## Floor connection

- Flange variants as required by the customer

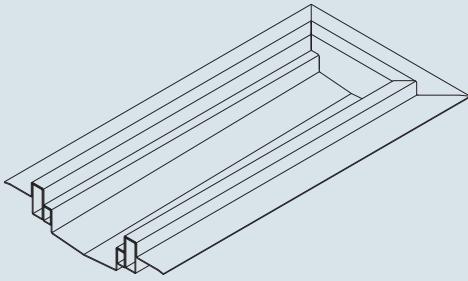

### Bonding flange

**HF**

For connection to plastic floorings or tiled floors using the thin-bed method. This adhesive flange is unperforated, in both floor inlet and channel, made impervious to fluids and with a standard width of 50 mm. It can be attached to either a square or round inlet edge of a single-part floor drain, or to the attachment piece of a two-part floor drain. Material depends on the material chosen for the housing.

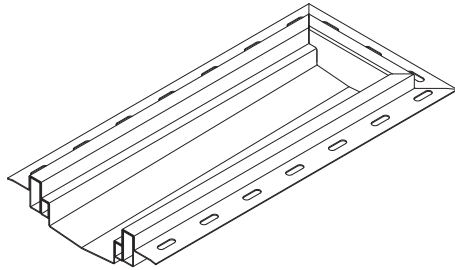

### Attachment flange

**AF**

For better connection of plastic floorings to the floor drains or channels. In order to achieve the best possible joint between floor covering and drainage element the attachment flange is perforated and usually only tack welded. It is 40 mm wide as standard and can be attached to both a square or round inlet edge of a single-part floor drain or to the attachment piece of a two-part floor drain. Material depends on the material chosen

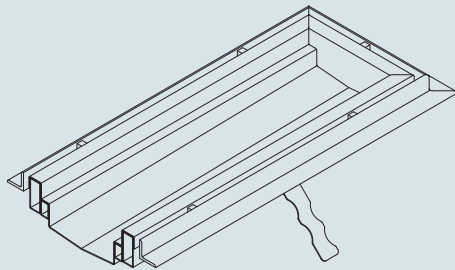

### Tile connection angle

**FAWI**

Protects the adjoining tiles against mechanical damage and is used to attach a maintenance and expansion groove in the event of thermal stress. Spacers must be removed before grouting.

## Special solutions



### Half-round channels – profile

This so-called flume water or feather channel is particularly suitable for discharging large quantities of water that contain lettuce leaves or feathers.

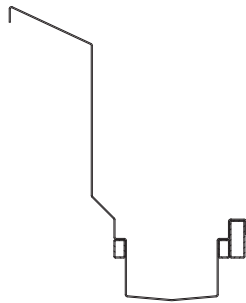

### Edge protection channels – combination

This combination solution is ideal for rooms where forklifts or lifting gear is used, where for drainage gradient reasons the drainage has been installed next to the walls.

At the same time one saves oneself the critical sealing point between the edge of the channel and the rising wall by having an upturn on the channel.

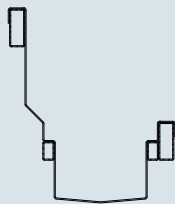

### Plinth channels

For hygienic reasons this variant is particularly suitable for underneath kitchen equipment because there is no need for a transition joint between the tiled plinth and the channel.



### Asymmetrical slot channel

Due to the traffic involved or for purely design reasons such an asymmetrical channel can be laid directly along the wall area.

At the same time one saves oneself the critical sealing point between the edge of the channel and the rising wall by having an upturn on the channel.

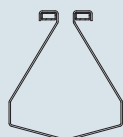

### Large volume slot channel

This special solution is an economical alternative to the combined trough channel and pipe.

Pollutants can be drained off in a sort of “open pipe” where it can also be seen at the same time.

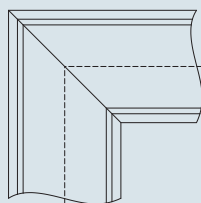

**Corner joint**

Both trough and slot channels are available as corner joints of any angle.

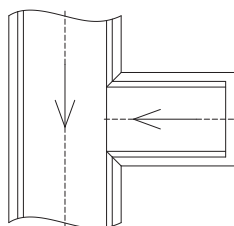

**Branch channel**

In order to specifically drain off large or hot quantities of water branch channels are ideal as feed-ins to the main channel. Your floor will be well protected against thermal and chemical stress.

**Examples of channel shapes**

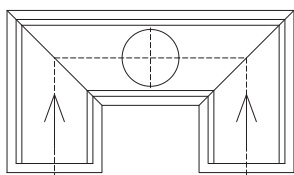
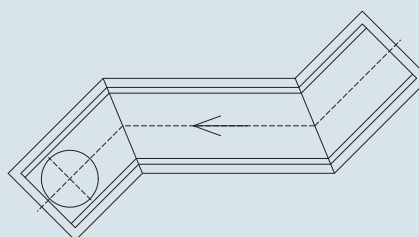
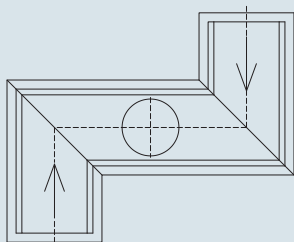

## Cover variants

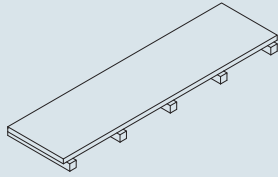

### Plate cover M125

**P**

Standard cover, capable of bearing heavy forklift operations. With 10 mm sheet thickness and reinforced with bracing welded underneath. Approved for Class M125 loads. 10 mm drain slots on both sides.

### Plate cover L15

**P/5**

Capable of bearing light traffic. With 5 mm sheet thickness and reinforced with bracing welded underneath. Approved for Class L15 loads. 10 mm drain slots on both sides.

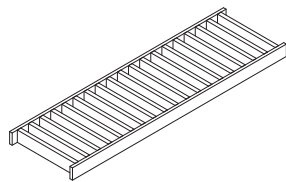

### Bar grate M125

**SR**

Capable of bearing heavy forklift operations, made of 8 mm support rods, clearance 18 mm. the waste water can drain better and faster through the bars. Approved for Class M125 loads.

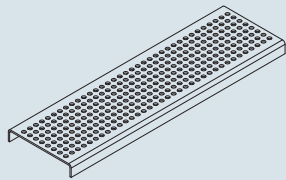

### Plate cover K3

**B**

Cover can be walked on, suitable for barefoot areas. Sheet thickness 3 mm, with round holes -  $\varnothing$  8 mm. Approved for Class L15 loads.

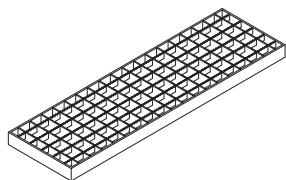

### Grating L15

**GR**

Capable of bearing light traffic, mesh size 25 x 25 mm, support rods in 2, 3 or 4 mm and if desired also available as non-slip (RH) variant, bearing bars in 12 x 2 mm. Approved for Class L15 loads.

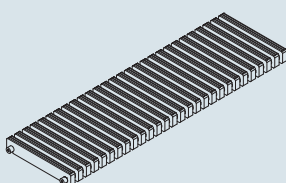

### Roll grate

**RR**

For covering overflow channels in swimming pools and convector shafts.

## Flap grate KR

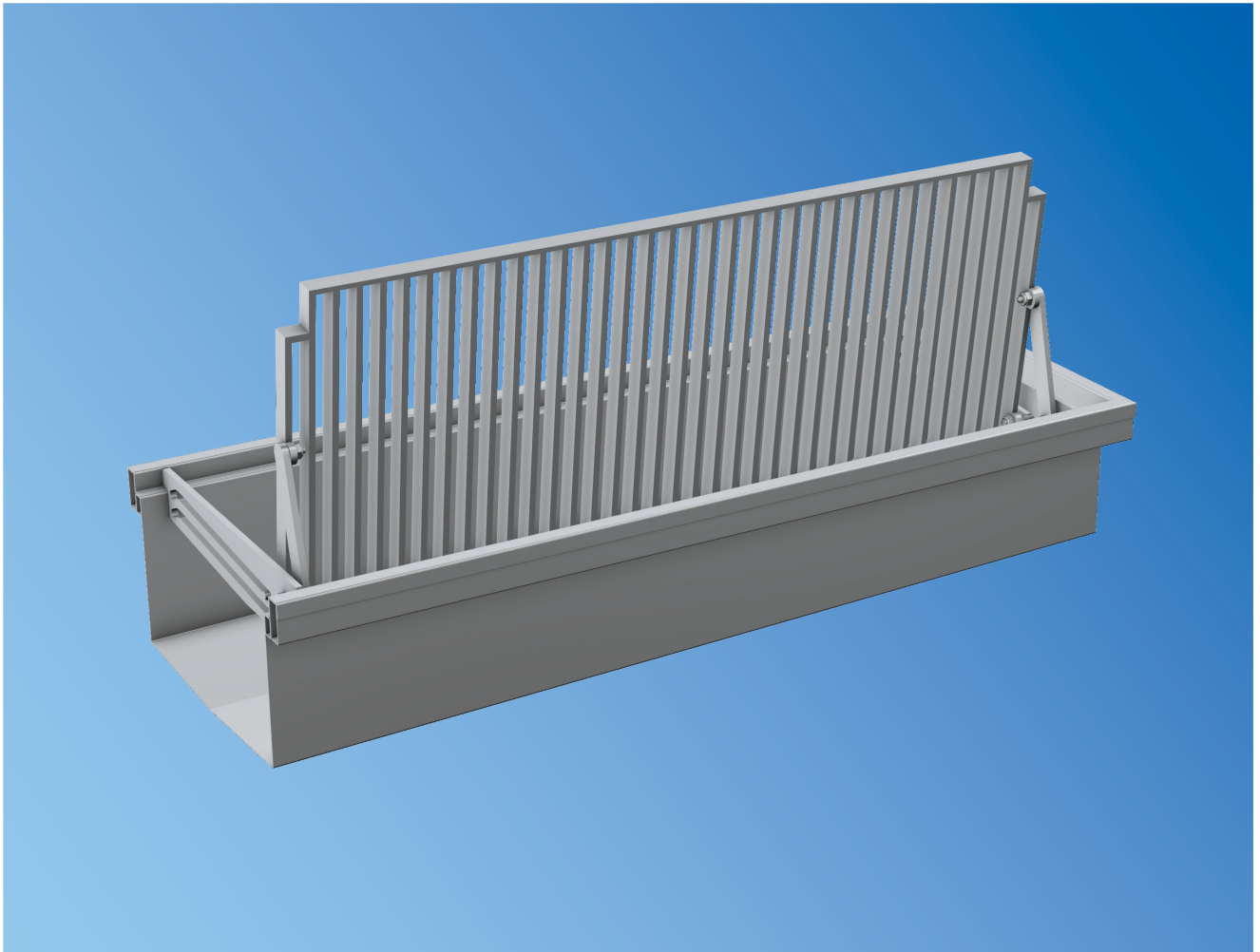

### Flap grate

Flap grate Model KR, positive guided opening and closing movement. An arrestor in the top dead centre prevents accidental closure. The opened grate can easily be cleaned over the channel, floor-cleaning possible from both sides. The grate is secured against unauthorised removal.

This flap grate is available from a profile width of 170 mm, and the rods can be arranged both laterally or longitudinally.



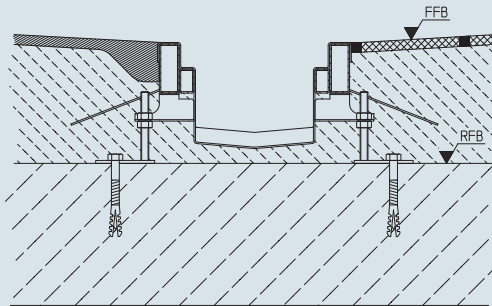

### Channel

1. Check the floor height at the building site.
2. Connect the channel drains (drainage pipe) to the existing ground pipe.
3. Align the channel elements with a fixed point or axis (e.g. wall, pillar etc.).
4. Weld or flange the individual channel elements to form one unit.
5. To enable an uncomplicated mounting position a height adjustment piece should be attached to every assembly support to counteract any unevenness of the floor.
6. Once the channel has been exactly levelled it should be anchored (bored) to the unfinished floor using the assembly supports or adjustable feet. Heights should be checked approximately every 1000 mm.
7. The channel is now to be sealed in at the right height with concrete (Remember that the floor covering still has to be applied!). It may be necessary to use wooden spacers so that the cross-sectional area of the channel is not constricted when the floor is poured.
8. When sealing the channel make sure that the underside of the channel is properly supported with concrete.

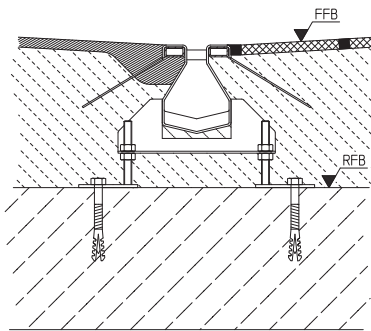

### Slot channel

1. Check the floor height at the building site.
2. Connect the channel drains (drainage pipe) to the existing ground pipe.
3. Align the channel elements with a fixed point or axis (e.g. wall, pillar etc.).
4. Weld or flange the individual channel elements to form one unit.
5. To enable an uncomplicated mounting position a height adjustment piece should be attached to every assembly support to counteract any unevenness of the floor.
6. Once the channel has been exactly levelled it should be anchored (bored) to the unfinished floor using the assembly supports or adjustable feet. Heights should be checked approximately every 1000 mm.
7. The channel is now to be sealed in at the right height with concrete (Remember that the floor covering still has to be applied!). **IMPORTANT:** The reinforcement profiles have to be sealed completely by the flooring material or the edge of the channel may separate from the floor. If the flooring used is epoxy resin flooring we recommend a wedge-shaped joint zone around the channel edge (see the right hand side of the schematic sketch).
8. When sealing the channel make sure that the underside of the channel is properly supported with concrete.



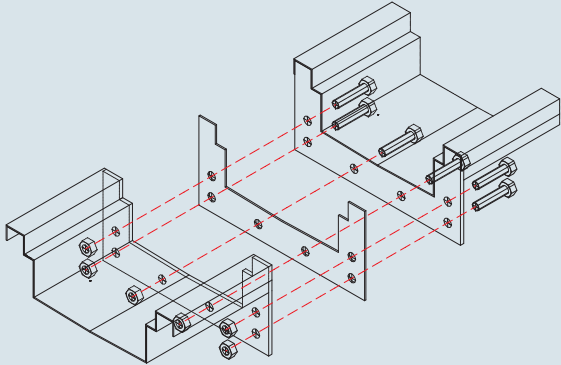

**Flange connections**

1. These directions are based on the installation instructions for the various channel types.
2. Remove any dirt from the sealing surfaces and examine the seal for damage.
3. After aligning the channel elements with a fixed point or axis (e.g. wall, pillar etc.) screw the elements together as shown in the drawing (and don't forget the seal).  
Make sure the seal sits properly and that the edges of the channels fit together properly. Then tighten the screws.
4. Continue assembly in accordance with the channel installation instructions.

**Sealing material**

Trade name:	Perbunan, beige			
Abbreviated description:	NBR 60 bright			
Chemical description:	Nitrile butadiene rubber			
Food unobjectionable acc. to:	BGVV XX1, Kat. 2			
Note:	KTW-approval			
Temperature:	- 30° C to + 80° C			
Suitable for:	Oil	Acid	Alkali	Ageing
	Conditional	Good	Good	Conditional

## Manhole SA - E - PTÄ

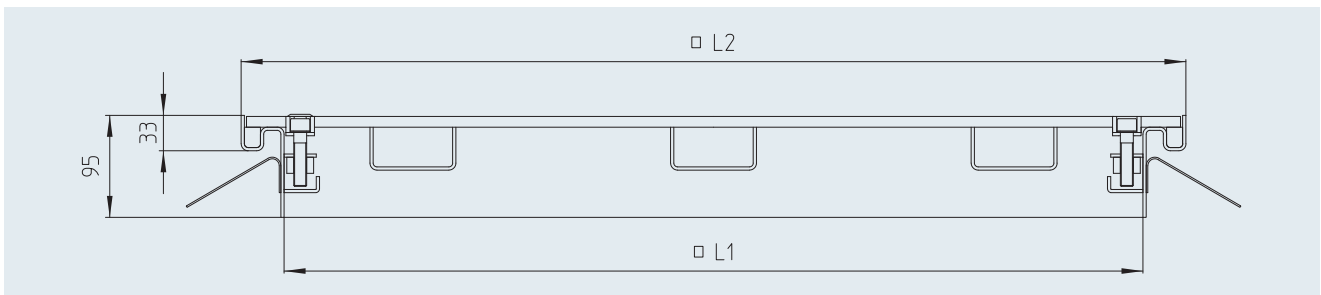
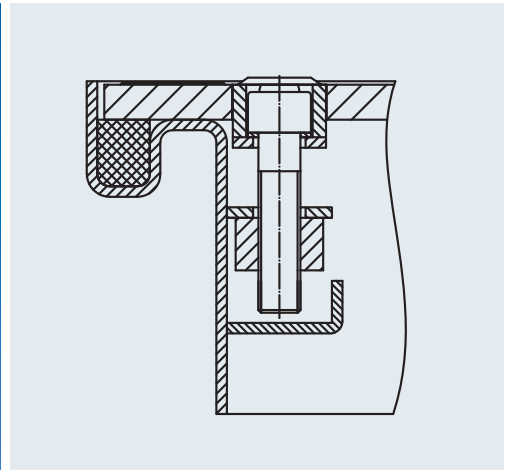
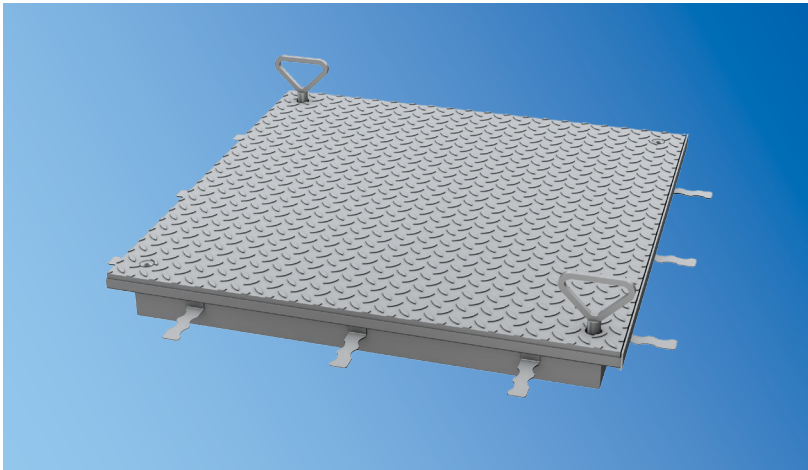

Model	Nominal size	L1 [mm]	L2 [mm]	Frame height [mm]
SA-E-PTÄ-600	600	600	680	33/95
SA-E-PTÄ-800	800	800	880	33/95
SA-E-PTÄ-1000	1000	1000	1080	33/95

### Load class

■ 15 kN ■ 50 kN ■ 125 kN

### Grade

■ 1.4301 (AISI 304) ■ 1.4571 (AISI 316 Ti)<sup>1)</sup>

### Description for use in tenders

Manhole right for forklifter traffic, square, test force according to DIN EN 124 and DIN 1229, Model SA-E-PTÄ. Available in smell and waterproof design with overhead silicone seal. Simple locking by means of fret-proof M12 VA/brass screw and nut combination, with screw-in lifting lugs. Frame is 3 mm plate, lid made of anti slip plate cover. Surface grain blasted.

Nominal size:	• 600 x 600 mm	• 800 x 800 mm	• 1000 x 1000 mm	• ..... x ..... mm
Load class:	• 15 kN	• 50 kN	• 125 kN	
Grade:	• 1.4301 (AISI 304)		• 1.4571 (AISI 316 Ti) <sup>1)</sup>	
Flange variants:	• Attachment flange		• Adhesive flange, t = 3,0mm	
	• Bonding flange			

We will be pleased to provide a description for specific objects for use in tenders.

<sup>1)</sup> If grade 1.4571 (AISI 316Ti) is used, some components may be made of grade 1.4404 (AISI 316) for construction reasons.

## Manhole SA - RD - PTÄ

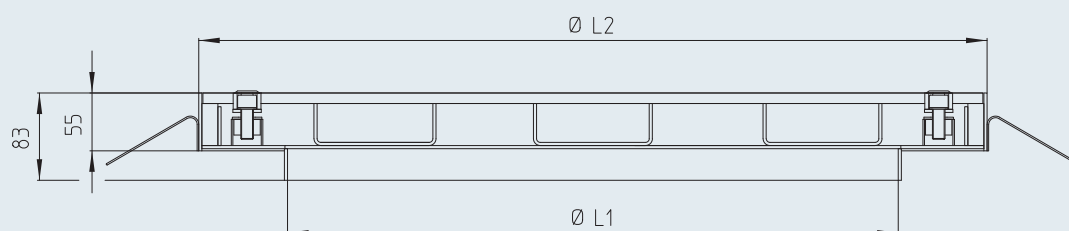
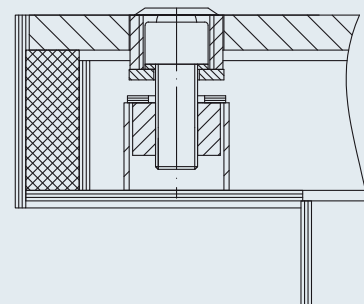
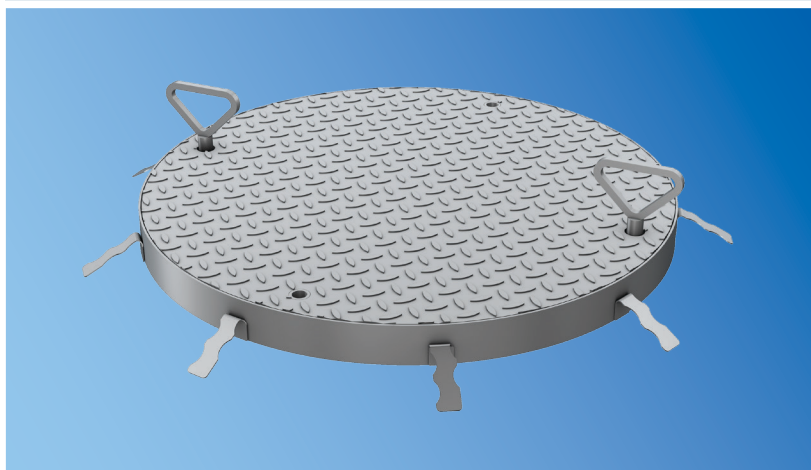

Model	Nominal size	Ø L1 [mm]	Ø L2 [mm]	Frame height [mm]
SA-RD-PTÄ-600	600	580	750	55/83
SA-RD-PTÄ-800	800	780	950	55/83
SA-RD-PTÄ-1000	1000	980	1150	55/83

### Load class

■ 15 kN ■ 50 kN ■ 125 kN

### Grade

■ 1.4301 (AISI 304) ■ 1.4571 (AISI 316 Ti)<sup>1)</sup>

### Description for use in tenders

Manhole right for forklifter traffic, round, test force according to DIN EN 124 and DIN 1229, Model SA-RD-PTÄ. Available in smell and waterproof design with overhead silicone seal. Simple locking by means of fret-proof M12 VA/brass screw and nut combination, with screw-in lifting lugs. Frame is 3 mm plate, lid made of anti slip plate cover. Surface grain blasted.

Nominal size:	• 600 mm	• 800 mm	• 1000 mm	• ..... mm
Load class:	• 15 kN	• 50 kN	• 125 kN	
Grade:	• 1.4301 (AISI 304)	• 1.4571 (AISI 316 Ti) <sup>1)</sup>		
Flange variants:	• Attachment flange • Bonding flange		• Adhesive flange, t = 3,0 mm	

We will be pleased to provide a description for specific objects for use in tenders.

<sup>1)</sup>If grade 1.4571 (AISI 316Ti) is used, some components may be made of grade 1.4404 (AISI 316) for construction reasons.

# Manhole SA-E-BTF

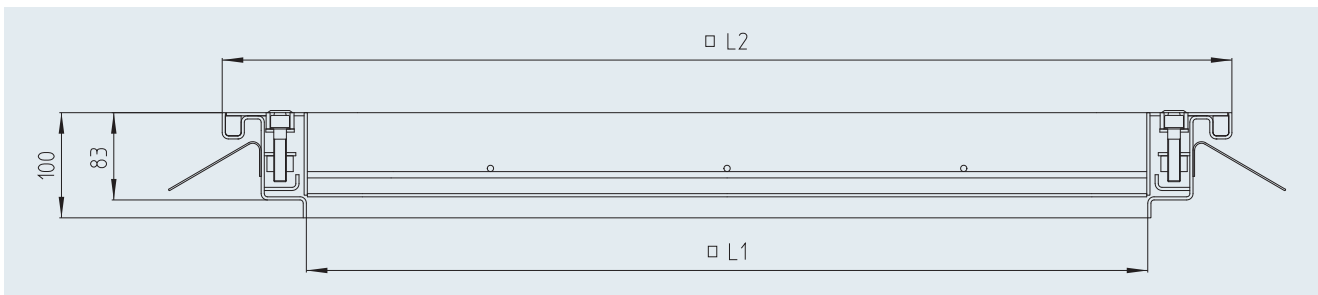
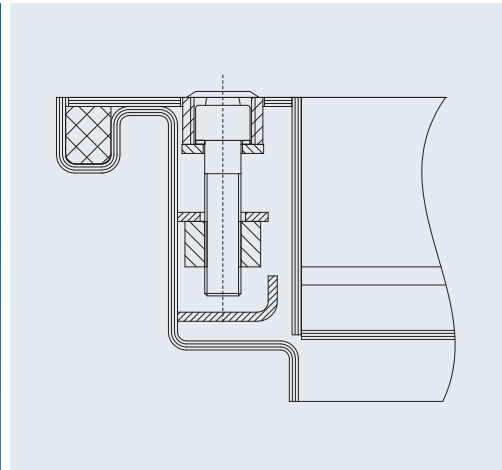
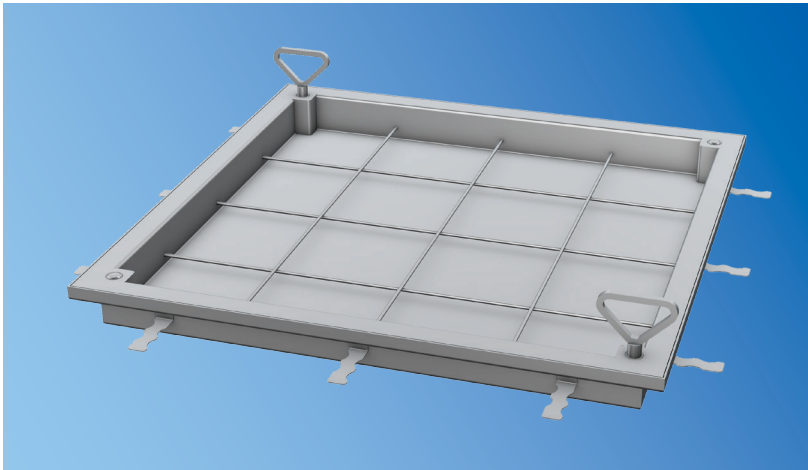

Model	Nominal size	L1 [mm]	L2 [mm]	Frame height [mm]
SA-E-BTF-600	600	600	760	83/100
SA-E-BTF-800	800	800	960	83/100
SA-E-BTF-1000	1000	1000	1160	83/100

## Load class

■ 50 kN

## Grade

■ 1.4301 (AISI 304) ■ 1.4571 (AISI 316 Ti)<sup>1)</sup>

## Description for use in tenders

Manhole, for surfaces of your choice, square, load class 50kN, test force according to DIN EN 124 and DIN 1229, Model SA-E-BTF. Available in small and waterproof design with overhead silicone seal. Simple locking by means of fret-proof M12 VA/brass screw and nut combination, with screw-in lifting lugs. Cover and frame are made of 3 mm plate, cover as closed tray with welded reinforcement bars. Surface grain blasted.

Nominal size:	• 600 x 600 mm	• 800 x 800 mm	• 1000 x 1000 mm	• ..... x ..... mm
Grade:	• 1.4301 (AISI 304)		• 1.4571 (AISI 316 Ti) <sup>1)</sup>	
Opt: Flange variants:	• Attachment flange		• Adhesive flange, t = 3,0 mm	
	• Bonding flange			

We will be pleased to provide a description for specific objects for use in tenders.

<sup>1)</sup> If grade 1.4571 (AISI 316Ti) is used, some components may be made of grade 1.4404 (AISI 316) for construction reasons.

## Manhole SA-RD-BTF

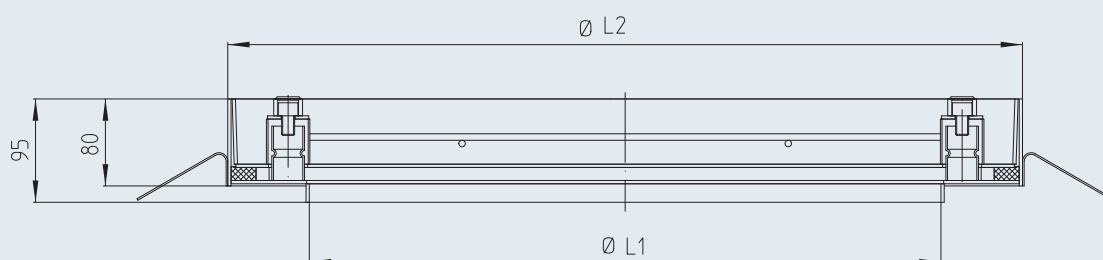
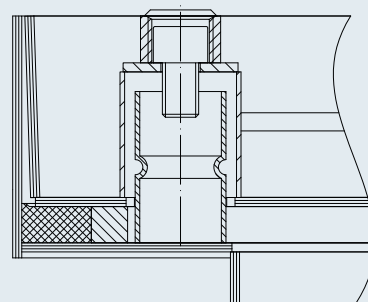
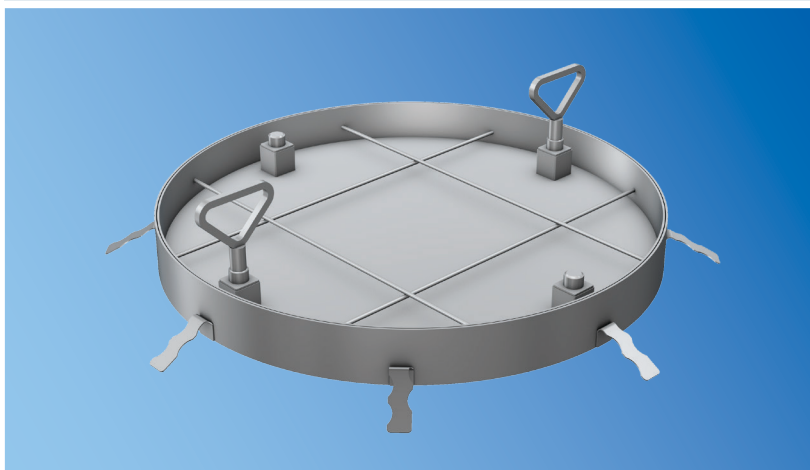

Model	Nominal size	Ø L1 [mm]	Ø L2 [mm]	Frame height [mm]
SA-RD-BTF-600	600	580	730	80/95
SA-RD-BTF-800	800	780	930	80/95
SA-RD-BTF-1000	1000	980	1130	80/95

### Load class

■ 50 kN

### Grade

■ 1.4301 (AISI 304) ■ 1.4571 (AISI 316 Ti)<sup>1)</sup>

### Description for use in tenders

Manhole, for surfaces of your choice, round, load class 50kN, test force according to DIN EN 124 and DIN 1229, Model SA-RD-BTF. Available in smell and waterproof design with bottom-mounted silicone seal. Simple locking by means of fret-proof M12 VA/brass screw and nut combination, with screw-in lifting lugs. Cover and frame made of 3 mm plate, cover as closed tray with welded reinforcement bars. Surface grain blasted.

Nominal size:	• 600 mm	• 800 mm	• 1000 mm	• ..... mm
Grade:	• 1.4301 (AISI 304)		• 1.4571 (AISI 316 Ti) <sup>1)</sup>	
Opt. Flange variants:	• Attachment flange		• Adhesive flange, t = 3,0 mm	
	• Bonding flange			

We will be pleased to provide a description for specific objects for use in tenders.

<sup>1)</sup> If grade 1.4571 (AISI 316Ti) is used, some components may be made of grade 1.4404 (AISI 316) for construction reasons.



# Pipe leadthrough RDFN

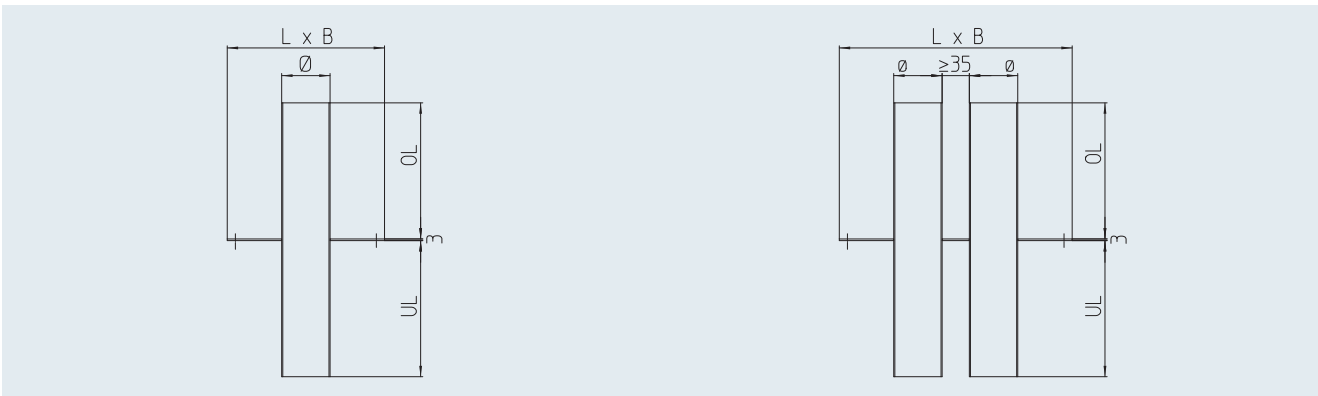
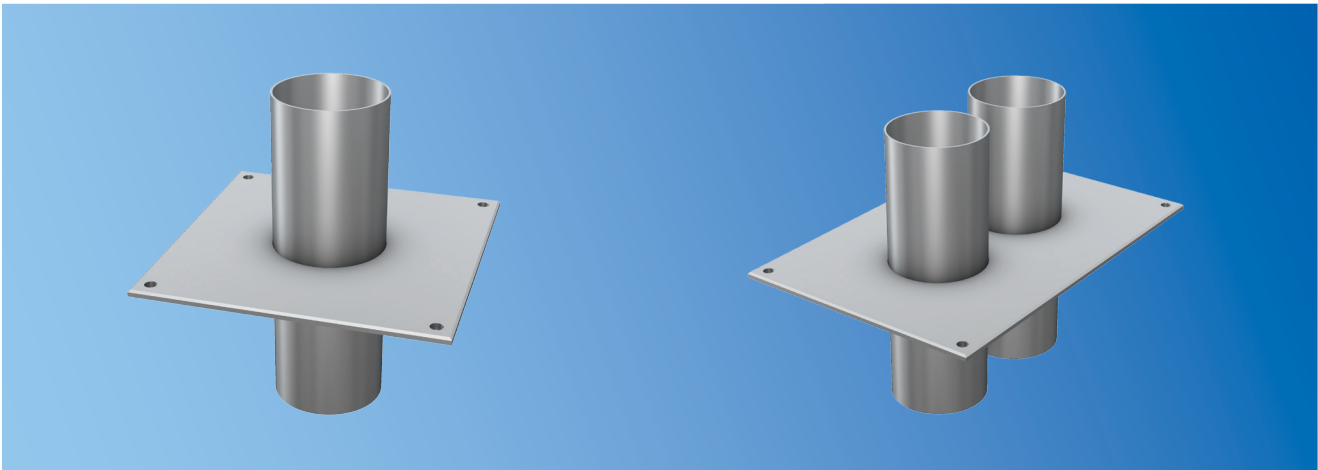

## Description for use in tenders

Pipe leadthrough, Model RDFN, with 3 mm thickness bonding flange without moveable flange. Ascender and descender of the sleeve tube each 250 mm long, without cover. Bonding flange with 4 mounting holes. Stained surface.

Grade:	• 1.4301 (AISI 304)	• 1.4571 (AISI 316 Ti) <sup>1)</sup>		
Flange plate:	• ..... x ..... mm			
Nos sleeve tubes:	• ..... No.			
Ø Sleeve tubes:	• 21.3 x 2.0 mm	• 26.9 x 2.0 mm	• 33.7 x 2.0 mm	• 40.0 x 2.0 mm
	• 42.4 x 2.0 mm	• 48.3 x 2.0 mm	• 54.0 x 2.0 mm	• 60.3 x 2.0 mm
	• 70.0 x 2.0 mm	• 76.1 x 2.0 mm	• 88.9 x 2.0 mm	• 108.0 x 2.0 mm
	• 114.3 x 2.0 mm	• 129.0 x 2.0 mm	• 139.7 x 2.0 mm	• 154.0 x 2.0 mm
	• 168.3 x 2.0 mm	• 204.0 x 2.0 mm	• 219.1 x 2.0 mm	• other ø on request
Optional	Ascender OL:	• ..... mm		
	Descender UL:	• ..... mm		
	Flange:	• Moveable flange in 3 mm sheet metal profile, thread bolt M 10 x 25 mm		
	Other optional equipment:	• Bonding flange with wall edging		

We will be pleased to provide a description for specific objects for use in tenders.

<sup>1)</sup> If grade 1.4571 (AISI 316Ti) is used, some components may be made of grade 1.4404 (AISI 316) for construction reasons.

## Pipe leadthrough RDFN

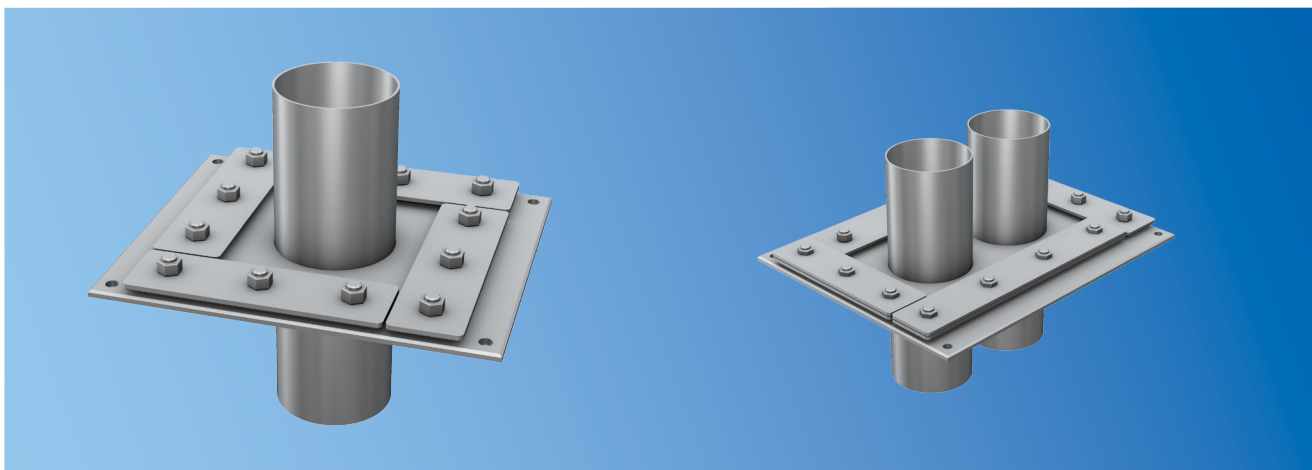

### Description for use in tenders

Pipe leadthrough, Model RDFD, with 6 mm thickness fixed and moveable flange according to DIN 18195-9. Ascender and descender of the sleeve tubes each 250 mm long. Fixed flange with 4 mounting holes. Surface pickled.

Grade:	• 1.4301 (AISI 304)	• 1.4571 (AISI 316 Ti) <sup>1)</sup>		
Flange plate:	• ..... x ..... mm			
Nos sleeve tubes:	• ..... No.			
Ø Sleeve tubes:	• 21.3 x 2.0 mm	• 26.9 x 2.0 mm	• 33.7 x 2.0 mm	• 40.0 x 2.0 mm
	• 42.4 x 2.0 mm	• 48.3 x 2.0 mm	• 54.0 x 2.0 mm	• 60.3 x 2.0 mm
	• 70.0 x 2.0 mm	• 76.1 x 2.0 mm	• 88.9 x 2.0 mm	• 108.0 x 2.0 mm
	• 114.3 x 2.0 mm	• 129.0 x 2.0 mm	• 139.7 x 2.0 mm	• 154.0 x 2.0 mm
	• 168.3 x 2.0 mm	• 204.0 x 2.0 mm	• 219.1 x 2.0 mm	• other Ø on request
Optional	Ascender OL:	• ..... mm		
	Descender UL:	• ..... mm		
	Other optional equipment:	• Bonding flange with wall edging		

We will be pleased to provide a description for specific objects for use in tenders.

<sup>1)</sup> If grade 1.4571 (AISI 316Ti) is used, some components may be made of grade 1.4404 (AISI 316) for construction reasons.



The instructions are provided as an orientation, and do not serve as grounds for any warranty or damage claims.

## Contents

1. Introduction
2. Resistance to corrosion
3. Initial cleaning
4. Routine cleaning
5. Cleaning agents
6. Cleaning utensils
7. Cleaning intervals

### 1. Introduction

It is well known that stainless steel has far greater resistance to corrosion than non-alloyed and low alloy steels. They are resistant to numerous aggressive media, and do not require any additional surface protection.

Deposits on the surface of the stainless steel can however impair the corrosion resistance, which is why the stainless steel products you have purchased should receive a basic amount of cleaning and care.

### 2. Resistance to corrosion

The alloy constituents included in the grade result in a passive layer, only a few atoms thick, being created on the surface. The impact of oxygen in air and water results in this passive layer being regenerated time and again. Prerequisite for this is a bare metallic surface that is free of impurities.

### 3. Initial cleaning

Initial basic cleaning is usually carried out after building work has been completed, and before the products have been put into initial operation by the developer.

Stainless steel surfaces are often effectively protected by **plastic film** during transport, storage and assembly. This protective film does not however provide permanent protection against light and ultraviolet radiation, and are difficult to remove if in place for a longer period of time. Remnants of protective film that are difficult to remove are left on the surface. It is therefore recommended that the protective film is removed as soon as it is no longer needed for protection on the building site, and within a few weeks of delivery at the latest. The film should always be peeled off from top to bottom. In order to avoid material sticking to the surface that

could prevent creation of the passive layer, any remnants of film should be removed using warm water and a gentle detergent.

**Lime and mortar splashes** can be removed with diluted phosphoric acid, and the area then thoroughly rinsed with a generous amount of clear water. Using demineralised water counteracts the creation of lime stains.

Several detergent manufacturers offer special products for this purpose. Under no circumstances should you use cement stain remover for tiles or diluted hydrochloric acid. If either of these products should find its way onto the stainless steel surface, it must be immediately removed with plenty of clear water.

Other building contractors, e.g. tile layers, are not always aware of the damage that lime stain remover and diluted hydrochloric acid can cause to stainless steel.

**Iron particles** from tools, scaffolding and transportation equipment must be removed without delay. Grinding dust, swarf and welding splatter from work being done on construction steel in the vicinity of work with stainless steel can accelerate rusting if they are deposited on stainless steel. This can result in localised penetration of the passive layer of the stainless steel causing punctiform corrosion.

If these contaminations are recognised in time, they can be removed using standard household (non-ferrite) cleaning pads or special cleansing products. Subsequent rinsing with plenty of clear water will clean the surface and give the material the chance to rebuild the passive layer.



## Cleaning and care instructions for stainless steel



If corrosion has already started, a mechanical (or preferably stain) treatment of the surface is unavoidable. Stains are also available in paste form for local application. It is important to observe all environmental protection rules and the manufacturer's health and safety instructions when using such products. Specialised firms will often carry out such work on site on a subcontract basis.

Treatment with stain will fully restore the original corrosion protection of stainless steel. This can however result in optical changes to the surface, so that it is necessary to finish the surface by sanding and polishing it. It is therefore recommended that contamination by tramp iron should be avoided from the very start, e.g. by using protective film or by carrying out all stainless steel work after work with construction steel has been completed.

### 4. Routine cleaning

Where stainless steel is used **outside**, the cleansing effect of rain is usually sufficient to prevent damaging deposits. Surfaces that cannot be reached by rain should be cleaned to ensure that there is no build up of contamination from air pollution. Cleaning stainless steel is particularly important in coastal and industrial surroundings where there can be a concentration of chlorides and sulphur dioxide (this also includes the undersides of horizontal profiles) for which the chosen type of steel is not designed.

Where stainless steel is used **inside**, it is especially important to avoid and clean fingerprints. Stainless steel is available with a great variety of surfaces, some of which are specially designed for use in areas frequented by the public. It is possible to minimise later cleaning costs by making the right choice of surface during the planning phase.

Fingerprints are an initial phenomenon with the popular brushed and sanded surfaces. Their visibility is significantly reduced after several cleaning sequences.

### 5. Cleaning agents

A solution of washing up liquid is usually sufficient for removing **fingerprints**.

Some manufacturers of cleaning materials offer special products whose cleansing effect is enhanced by a care product. Such cleaning agents completely remove fingerprints, leaving behind a fine film which gives the treated surfaces a homogenous appearance. After cleaning, the surface should be polished with a dry cloth.

**Bright annealed and mirror polished** surfaces can be treated with chloride-free glass cleaners.

**Stubborn dirt** can be removed using standard household cleansing milk, which also removes lime stains and minor discolorations. Subsequent rinsing with demineralised water (as used for steam irons, and usually available in supermarkets) prevents lime stains being created as it dries off. The surface should then be given a dry polishing. Scouring powder is not suitable, as it will scratch the surface.

**Very oily and greasy dirt** can be removed using alcohol-based cleaning agents and solvents, e.g. rectified spirit, isopropyl alcohol or acetone, which are quite safe for stainless steel. Here it is necessary to make sure that the cleaning process does not spread the partially dissolved dirt across the whole surface. Cleaning must therefore be repeated using fresh cloths until all traces have been removed.

Special alkaline and solvent-based cleaning agents are available for **paint and graffiti**. Knives and scrapers should be avoided, because they will scratch the surface.

Seriously neglected surfaces can also be treated with polish, such as that used for looking after chrome on cars. Another option is rubbing compound normally used for aged car paint, whereby it is necessary to take care because it can leave scratches on stainless steel.

Another alternative is special stainless steel cleaner that contains phosphoric acid, as recommended above for the removal of tramp iron contamination. When using this cleaner, it is important that the whole surface is treated to avoid staining.

Whenever cleaning is carried out it is always necessary to observe environmental and health and safety rules.

#### Cleaning agents that are unsuitable for stainless steel include:

- Products containing chlorides, especially products containing hydrochloric acid,
- Bleaches (in case of accidental application or bleach splashes the stainless steel should be generously rinsed with clear water),
- Silver polish.



## Cleaning and care instructions for stainless steel



### 6. Cleaning utensils

A **damp cloth or leather** is usually sufficient to remove fingerprints.

Standard household (**iron-free**) **cleaning pads** are used for more stubborn dirt. On no account should abrasive pads that contain iron, steel wool or steel brushes be used, because they will transfer rusting tramp iron to the surface of the stainless steel.

Soft **nylon brushes** are suitable for cleaning surfaces that have been roller-patterned. Steel brushes (especially carbon steel brushes) cause damage.

Where the surfaces have been brushed or sanded (2G, 2J, 2K in accordance with DIN 10088/3) they should always be brushed in the direction they have been brushed/sanded, and not across the “grain”.

When cleaning with water, the surfaces – especially in hard-water areas – should then be **dry wiped** to avoid creating lime stains. Demineralised water helps avoid this problem.

To prevent tramp iron contamination you must not use any cleaning utensils that have been previously used for “normal” steel. You are recommended to keep **separate cleaning utensils** for use on stainless steel surfaces.

### 7. Cleaning intervals

Cleaning intervals for stainless steel used indoors are basically the same as for any other surfaces. To keep the amount of work and costs to a minimum, the surfaces should always be cleaned before larger-scale soiling has a chance to build up.

In outside areas, stainless steel can be subjected to a range of corrosive conditions, e.g.

- Coastal atmosphere,
- Factory fumes,
- Chloride-containing spray,
- Air pollution and traffic fumes.

These factors can lead to discoloration over time. Cleaning agents that contain phosphoric acid will reliably remove any discoloration.

Where very high optical requirements are involved or where the stainless steel is in a corrosive atmosphere, a proven rule of thumb is to clean the surface as often as you would clean glass surfaces. Routine cleaning in low-contamination environments should be carried out every few years. Where there is more serious contamination, especially in covered areas not reached by rain, the surfaces should be cleaned at intervals of several months.

### 8. Source

Leaflet 965 – Cleaning and care of stainless steel in the building industry

(German Stainless Steel Information Office, Internet 2009)

## Cleaning and care agents



#### Sanding fleece

For removing dirt, corrosion and other soiling, also for matting surfaces and light deburring work.



#### Stainless steel finish

- Creates a nurturing and protective film on the surface to be treated,
- Removes plaster and wiping streaks, giving stainless steel a new shine.



#### Stainless steel cleanser

- Cleans stainless steel surfaces gently and thoroughly,
- Easily removes water marks, grease, tarnishing, adhesive and lime residues.

## References



**Dairy products** Nordmilch AG, Backensholzer Käserei, Uelzena eG, Hochwald Nahrungsmittel-Werke GmbH, Milch-Union Hocheifel eG, Humana Milchunion eG, Hochland GmbH, Campina GmbH, Milchwerke „Mittelelbe“ GmbH, Rücker's Ostsee Molkerei, Privatmolkerei Naarmann GmbH, Hansa-Milch AG, Osterhusumer Meierei Witzwort eG, Frischli Milchwerke GmbH, Müritz-Milch GmbH, DP Trockenwerk Beesten GmbH, Molkerei Söbbecke GmbH, Molkerei Gebr. Rogge GmbH & Co. KG, Molda AG, Molkereigenossenschaft Barmstedt e.G.

**Meat and sausage products** Böklunder- Plumrose GmbH & Co. KG, Probsteier Wurstfabrik GmbH & Co. KG, Danish-Crown, Afra Geflügel GmbH & Co. KG, Fleischhof Rasting GmbH, Blömer Fleisch GmbH, Fleischerei Guder GmbH, B. & C. Tönnies Fleischwerk GmbH & Co. KG, Simon-Fleisch GmbH, H. Redlfesen GmbH & Co. KG, Rügenwalder Mühle GmbH & Co. KG, Micarna SA, VION Convenience GmbH, Westfalenland Fleischwaren GmbH, Kurhessische Fleischwaren GmbH, Schlachthof Tummel GmbH & Co. KG, Herta GmbH, W. Brandenburg GmbH & Co. KG, Abraham Schinken GmbH & Co. KG, Zimbo Fleisch- und Wurstwaren GmbH & Co. KG, Haas GmbH, Geestland Putenspezialitäten GmbH, Paul Daut GmbH & Co. KG, Sauels Frische Wurst GmbH, BWE Brüterei Weser Ems GmbH & Co. KG, H. Kemper GmbH & Co. KG, Günter Badenhop Fleischwerke KG, Könecke Fleischwarenfabrik GmbH & Co. KG, Müller's Hausmacher Wurst GmbH & Co. KG, Barfuss GmbH, Westfleisch eG.

**Beverages, breweries & wineries** Krombacher Brauerei GmbH & Co. KG, Holsten Brauerei AG, Bitburger Braugruppe GmbH, Warsteiner Brauerei GmbH & Co. KG, RIHA Wesergold GmbH, Dinter GmbH, Hansa-Heemann AG, C. & A. Veltins GmbH & Co. KG, Uerige Obergärige Hausbrauerei GmbH, Bergquell Brauerei Löbau GmbH, Radeberger Gruppe KG, Oettinger Brauerei GmbH, Brau Union Österreich AG, König-Brauerei GmbH, Karlsberg Brauerei GmbH, Brauhaus Faust OHG, Cölner Hofbräu P. Josef Früh KG, Flensburger Brauerei GmbH & Co. KG, Mineralquelle Zurzach AG, Kornbrennerei Heydt GmbH & Co. KG, Zillertal Bier GmbH, Coca-Cola GmbH, Rotkäppchen Sektkellerei GmbH, Lichtenauer Mineralquellen GmbH, Niederrhein-Gold Tersteegen GmbH & Co. KG, Vöslauer Mineralwasser AG, Punica Getränke GmbH, Schwollener Sprudel GmbH & Co. KG, Eckes-Granini Deutschland GmbH, G. H. von Mumm'sches Weingut KG, Fachingen Heil- und Mineralbrunnen GmbH, Friesisches Brauhaus zu Jever GmbH & Co. KG, Mecklenburgische Brauerei Lübz GmbH, Adam Trautwein Weinkellerei, Münch-Bräu Eibau GmbH, Gerolsteiner Brunnen GmbH & Co., Krings Fruchtsaft GmbH, Badische Staatsbrauerei Rothaus AG, Köstritzer Schwarzbierbrauerei GmbH.

**Bakery products & confectionery** Klemme AG, Kamps GmbH, Harry-Brot GmbH, Dr. Oetker Tiefkühlprodukte KG, Brezelbäckerei Ditsch GmbH, Coppentrath & Wiese GmbH & Co., Audrey Cake GmbH, Schäfer's Brot- und Kuchen Spezialitäten GmbH, Märkisches Landbrot GmbH, Kuchenmeister GmbH, August Storck KG, Zentis GmbH & Co. KG, Schwartzauer Werke, Haribo GmbH & Co. KG, Ragolds Sweet GmbH, R & R Ice Cream Deutschland GmbH, Griesson – de Beukelaer GmbH & Co. KG, Sweet tec GmbH, Moll Marzipan GmbH, Katjes Fassin GmbH & Co. KG, Ludwig Schokolade GmbH & Co. KG, Glockenbrot Bäckerei GmbH & Co. KG, Conrad Schulte GmbH & Co. KG, Heemann GmbH, Merzenich-Bäckereien GmbH, Stollwerck GmbH.

**Fish & delicatessen** HOMANN Feinkost GmbH, Ostee Fisch GmbH & Co. KG, Deutsche See GmbH, Heiploeg Deutschland GmbH, Forellen Abel GmbH, Frozen Fisch International GmbH, Klaas Puhl Deutschland GmbH, Eyka Feinkost Vertriebs GmbH, Heinrich Kühlmann GmbH & Co. KG, Grossmann Feinkost GmbH, Petri Feinkost GmbH, Wernsing Feinkost GmbH & Co. KG, Elfin Feinkost GmbH, Füngers Feinkost GmbH & Co. KG, Havesta Feinkost Hans Westphal GmbH & Co. KG, Euro-Baltic Fischverarbeitungen GmbH, Appel Feinkost GmbH & Co. KG, Artur Heymann GmbH & Co. KG.

**General food processing & food trade** DE-VAU-GE Gesundkostwerk GmbH, Nestlé Deutschland AG, Wild Flavors GmbH & Co. KG, Masterfoods GmbH, Carl Kühne KG (GmbH & Co.), Real-SB-Warenhaus GmbH, Columbus Frischei GmbH, Famila Handelsmarkt Kiel GmbH & Co. KG, Deutsche Extrakt Kaffee GmbH, Landkost-Konserven Reinhold Klemme KG, Ewald Gelatine GmbH, Nutrilio GmbH, Unilever Deutschland Produktions GmbH & Co. KG, Fuchs GmbH & Co. KG, Silesia Gerhard Hank GmbH & Co. KG, Symrise GmbH & Co. KG, ALDI GmbH & Co. KG, Hela Gewürzwerke Hermann Laue GmbH & Co. KG, Krüger GmbH & Co. KG, Brückner-Werke KG, Vortella Lebensmittel W. Vortmeyer GmbH, H. & J. Brüggel KG, Iglo GmbH, Bischofszell Nahrungsmittel AG, Kraft Foods Deutschland GmbH, Freiburger Lebensmittel GmbH & Co. Produktions- und Vertriebs KG, Odenwald-Früchte GmbH, Heinrich Hamker Lebensmittelwerke GmbH & Co. KG, Wagner Tiefkühlprodukte GmbH.

**Pharmaceuticals & chemistry** H. C. Starck GmbH, Bremer Pharma GmbH, Glaxo Wellcome GmbH & Co. KG, Novartis Behring, Phyton Biotechnik GmbH, B. Braun Melsungen AG, Boehringer Ingelheim Pharma GmbH & Co. KG, BASF Pharma Chemikalien GmbH & Co. KG, Dr. Paul Lohmann GmbH KG, KVP Pharma- und Veterinär Produkte GmbH, Romaco Pharmatechnik GmbH, Next Pharma GmbH, Rottendorf Pharma GmbH, Bayer AG, Lohmann Animal Health GmbH & Co. KG, Procter & Gamble Germany GmbH, Bayer Schering Pharma AG, Merck KGaA.

**Machine and plant engineering** Frankenberger Maschinen- und Anlagenbau GmbH, Dr.-Ing. K. Busch GmbH, Joh. Heinr. Bornemann GmbH, Flensburger Schiffbaugesellschaft GmbH & Co. KG, Big Drum Engineering GmbH, Abel GmbH & Co. KG, Feige GmbH, Maschinpex Maschinenbau GmbH, CRE Rösler Electronic GmbH, Rovema Verpackungsmaschinen GmbH, Elan Schaltelemente GmbH & Co. KG, CENTRO Kontrollsysteme GmbH, Poly-Clip System Maschinenbau besch.haft. OHG, Nordischer Maschinenbau Rudolf Baader GmbH & Co. KG, Alpma GmbH, Kronos AG, Fristam Pumpem F. Stamp KG (GmbH & Co.).

