

JUST VERTICAL GROWERS GUIDE

THE EVE

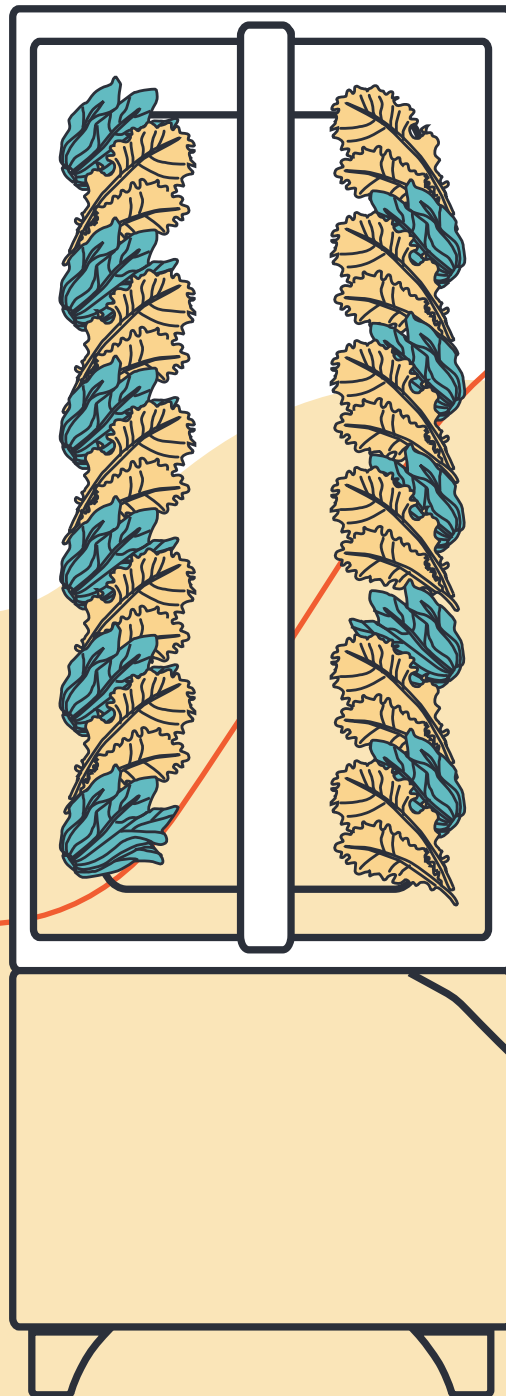

The Ultimate Growers Guide

Welcome to the food revolution! You are embarking on a journey towards a healthier and happier home. We are so glad that you could join us.

The important changes the world needs only happen because of people like you. This guide has everything you need to successfully grow with the EVE.

We believe in our product and have backed it with a 2-year warranty.

For your safety, read and understand all instructions prior to installing or turning on your garden. Failure to follow setup instructions or maintenance could lead to damages, injury, or fire. Make sure all parts shown on pages 10 and 11 arrived with your garden. If there are any missing parts do not start using your garden and immediately contact support@justvertical.com so we can get you growing!

We are always available if you have any questions, or concerns.

Access live chat on the web at: www.justvertical.com





Table of Contents

6

Getting Started

- 8 **Get To Know Your EVE**
- 9 **Inside Your EVE**
- 10-11 **Items Included With The EVE**
- 12-13 **Adding On The Feet**
- 14 **Mounting Your EVE To The Wall**
- 15 **Turning On Your EVE**
- 16-18 **Setting Your Timer**
- 19-22 **Planting Seeds**
- 23-28 **Pump Set-Up & Filling Your Reservoir**
- 29-31 **Adding Nutrients**

32

Maintenance

- 33 **8 Week Maintenance Schedule**
- 34 **Checking Plants**
- 35 **Checking Reservoir**
- 36 **Adding Nutrients**
- 36 **Checking Roots**
- 37 **Cleaning The Unit**

38

Pruning, Stakes & Pollination

- 39 **Pruning**
- 39 **Staking**
- 40 **Pollination**

42 **Harvesting**

43-44 **Common Leafy Greens & Herbs**

45-48 **Harvesting Strawberries & Tomatoes**

47 **Troubleshooting**

48 **There Is No Water Being Delivered To The Plants**

49 **Leaking From The Pods Onto Front Face**

50 **Leaking From The Bottom Plant Site**

51 **Water Is Leaking From An Inside Pipe**

51 **No Power To The Timer**

51 **Light Is Flickering**

52 **Plants Not Receiving Enough Water**

53-55 **Blockage In The Supply Line Or Drain**

56 **Timer Troubleshooting**

57-58 **Troubleshooting Pests**

59-60 **Troubleshooting Plant Growth**



GETTING STARTED

Set-up

Setting up the EVE is very simple and, thanks to a little bit of work on our end, you'll need just a few minutes once it arrives to get growing. We've kept it quick for you because you have better things to do (like tasting our 10 different kinds of kale!).



Get To Know Your EVE

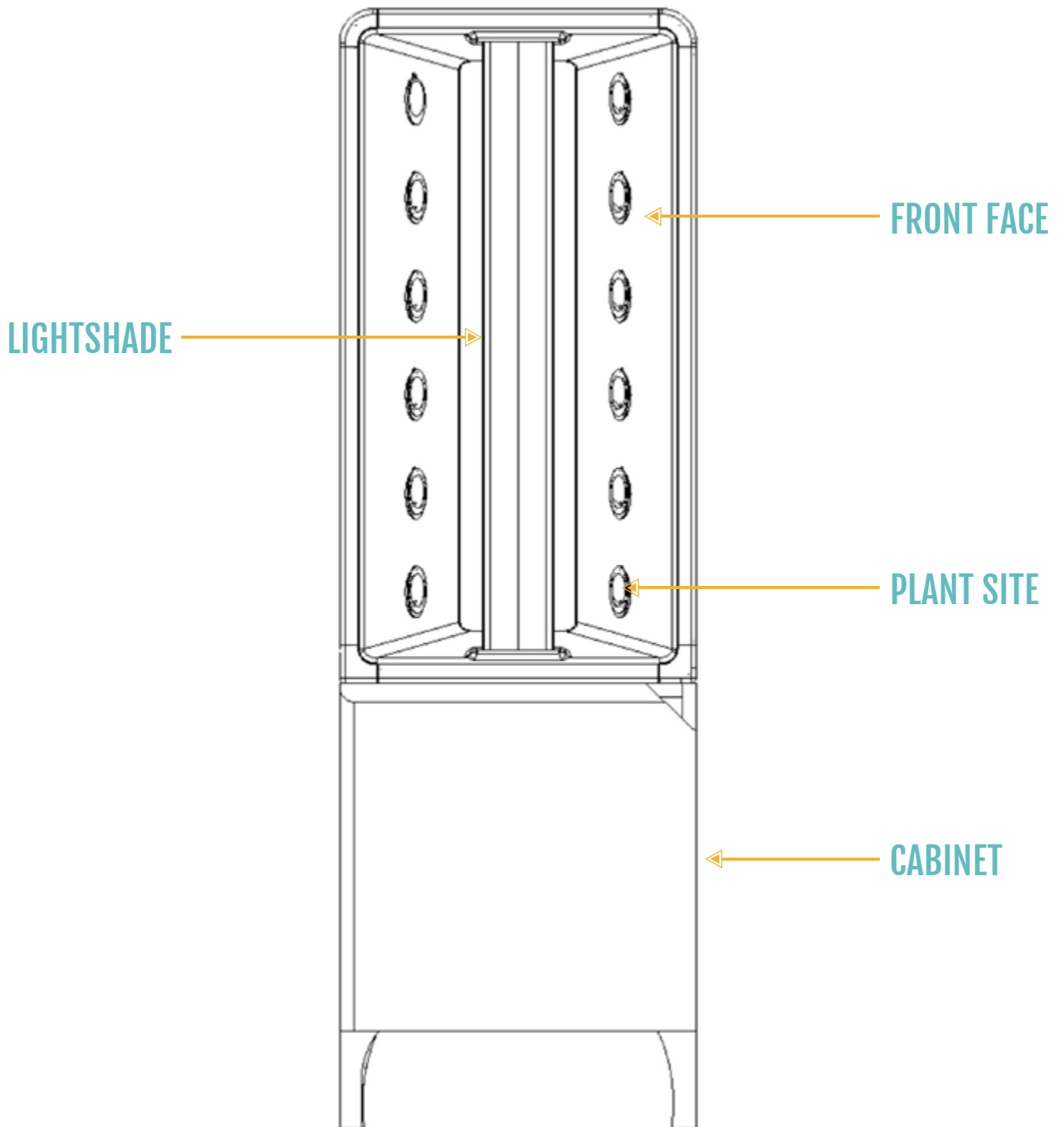

Inside Your EVE

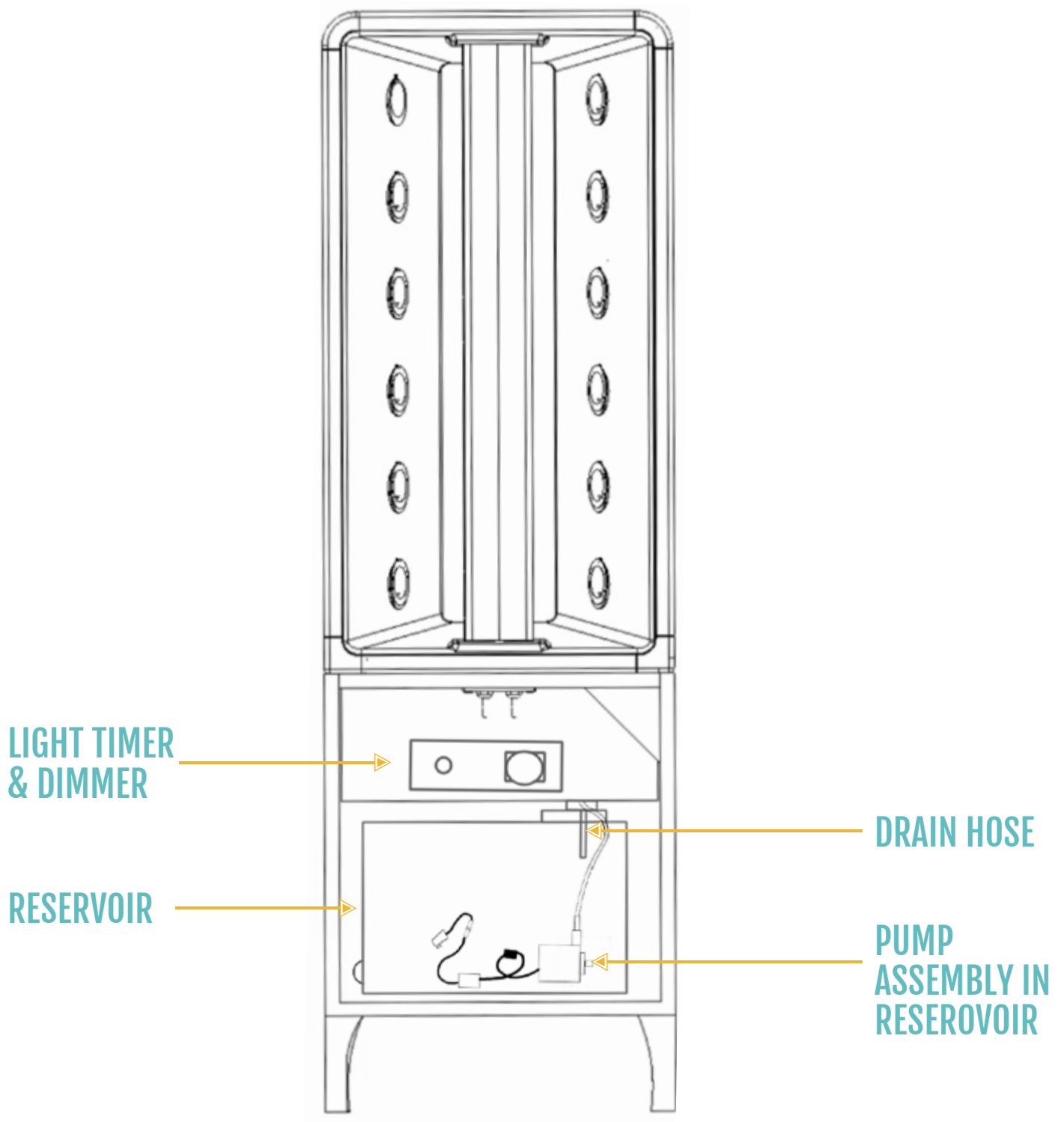

Items Included With The EVE

GFCI Cable

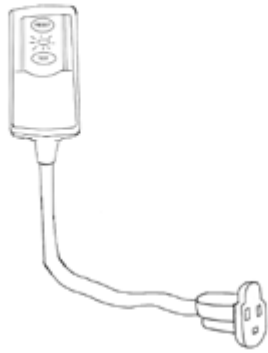

x1

Seedling Kit

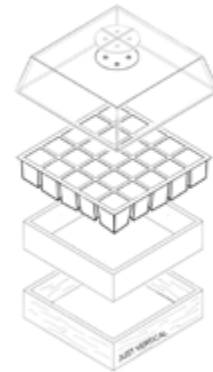

x1

Peat Moss Grow Plug



x16

Seed Pack

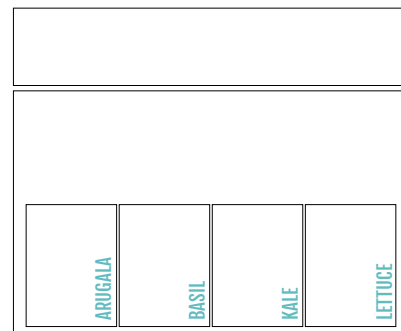

x1

Nutrient Bottles

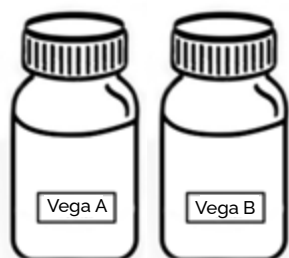

x1

Wall Mount



x1

Pump Assembly In Reservoir

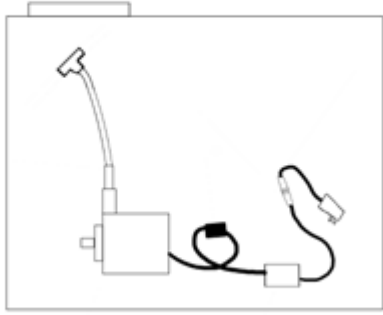

Power Bar



x1

Pods



x12

EVE Feet



x4

EVE Screws



x16



1

Adding On The Feet

1

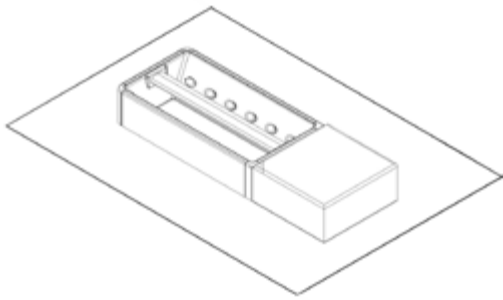

Lay down the EVE either on the cardboard packaging or on a carpet or rug.

2

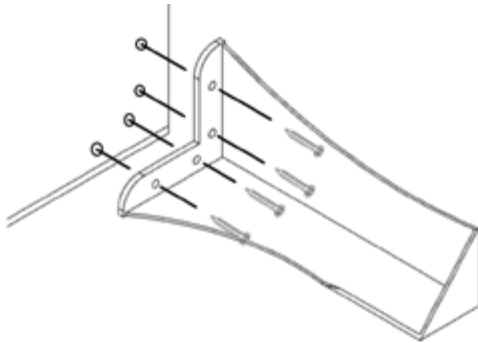

Align holes on the feet with the holes on the cabinet and insert the screws.

3

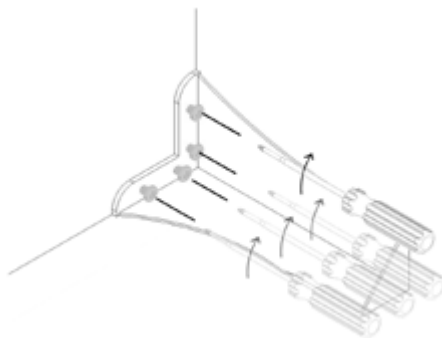

Use a screwdriver to tighten the screws.

4

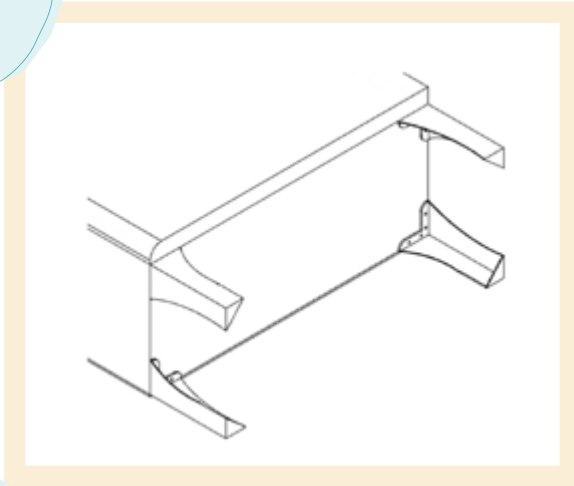

Repeat for the 3 other feet.

5

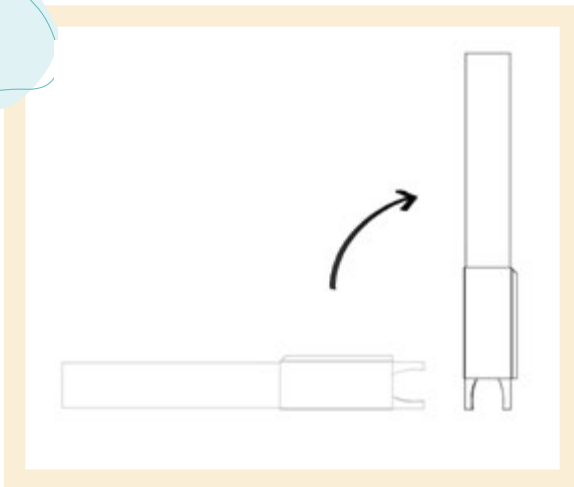

Put the EVE back into an upright position.

2

Mounting Your EVE To The Wall

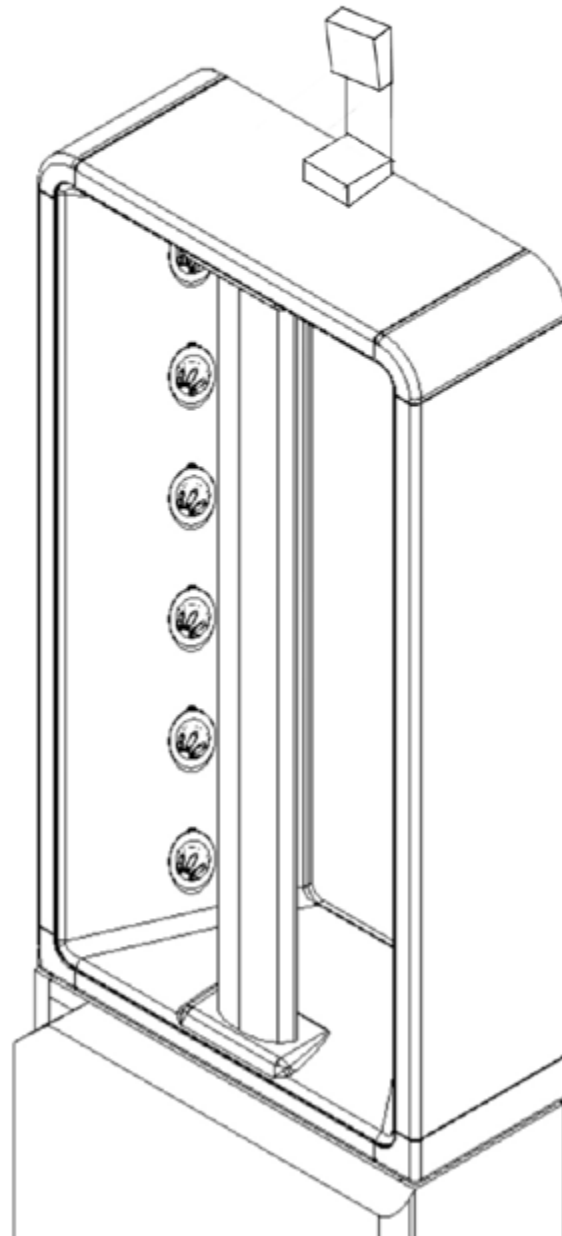

3

Turning On Your EVE

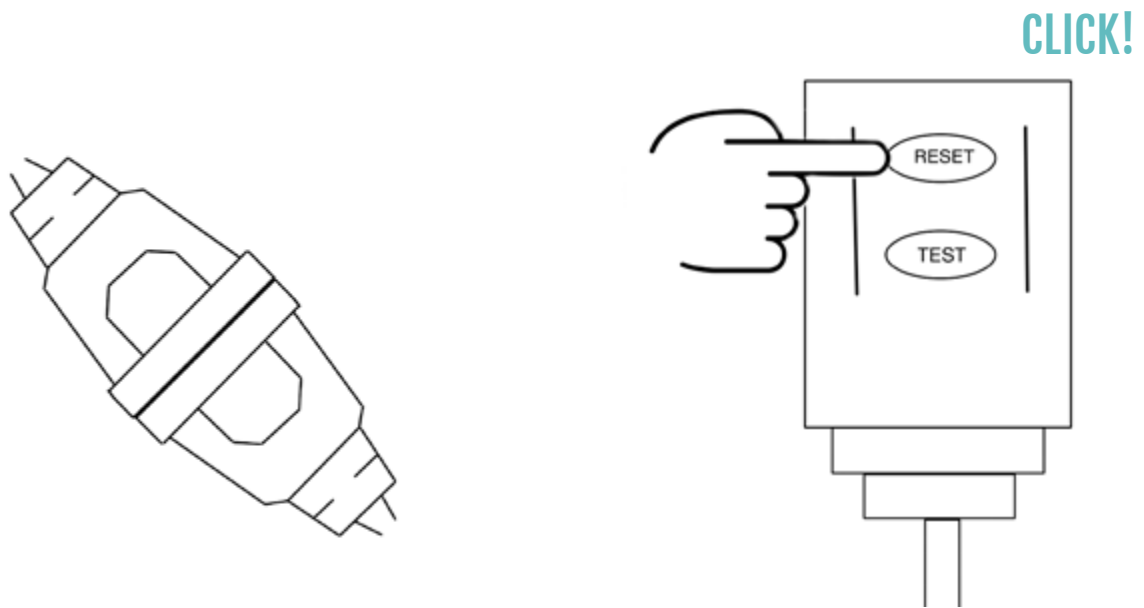
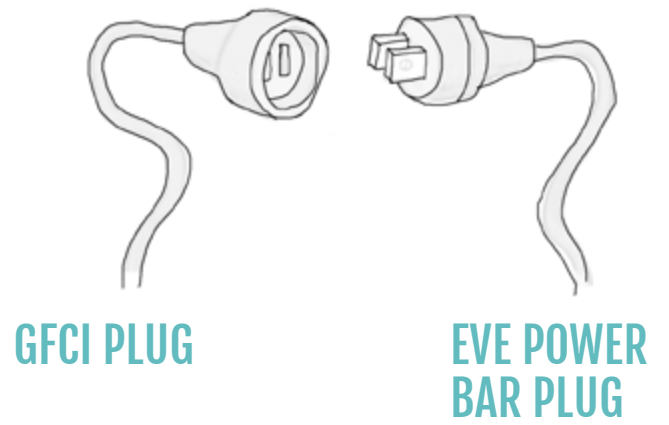
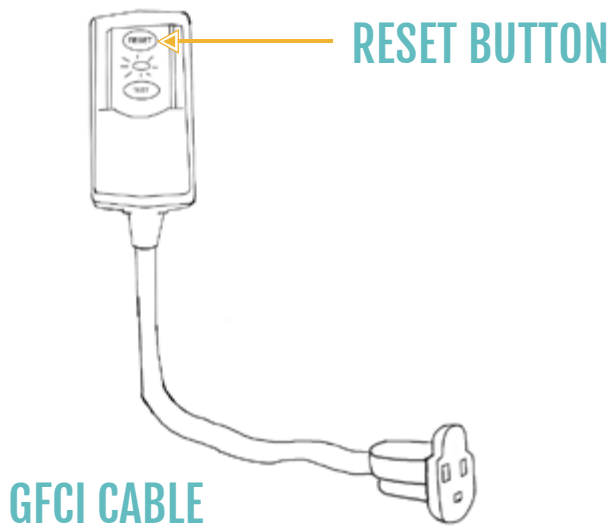

3

Setting Your Timer

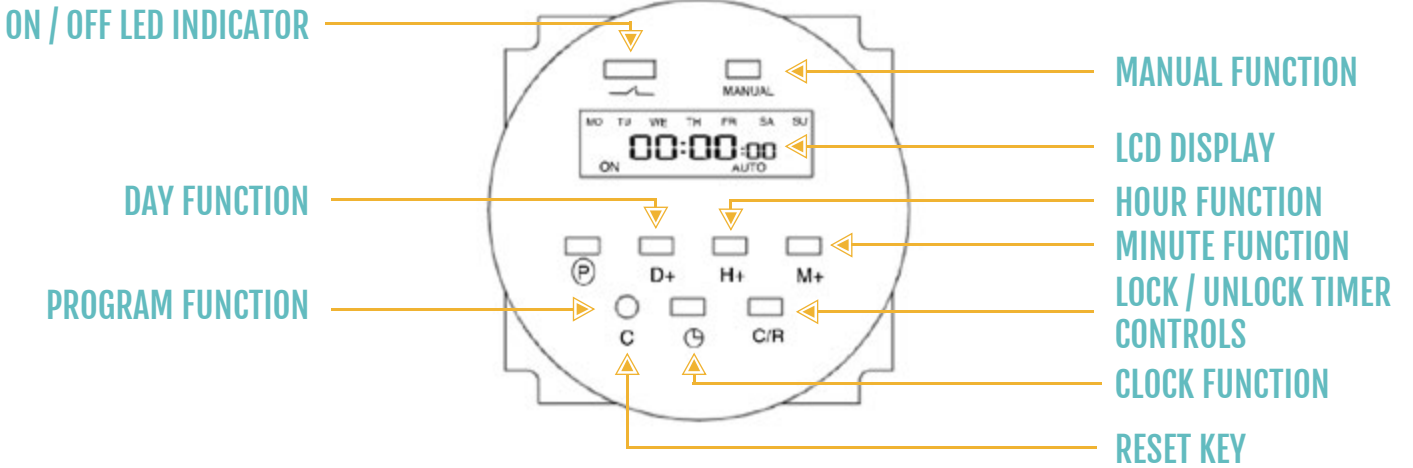

WHEN THE TIMER IS PLUGGED IN, PRESS THE 'C' KEY TO RESET THE TIMER



USE THE D+, H+, & M+ BUTTONS TO ADJUST THE CLOCK ON THE TIMER TO THE CURRENT TIME



ROTATE TO ADJUST LIGHT INTENSITY

TURN LEFT: MORE DIM
TURN RIGHT: MORE INTENSE

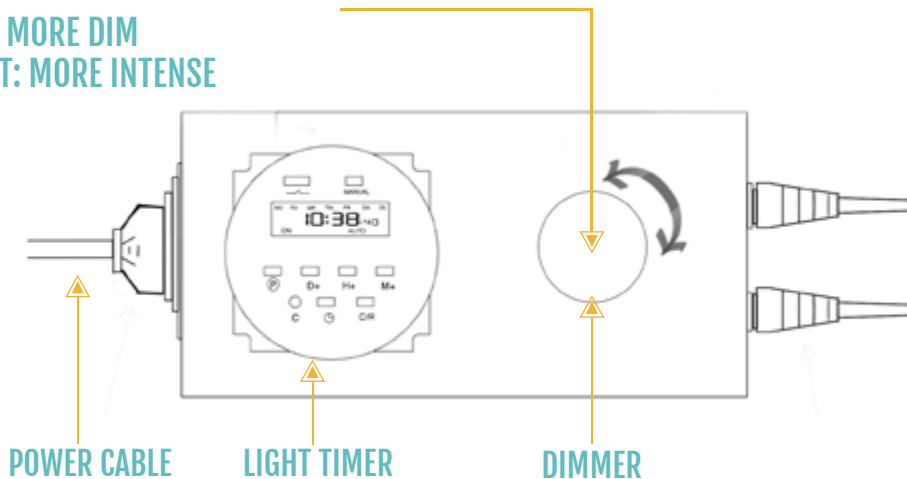

Note: Timer Autolock



You will not be able to make changes to your timer if the (a) symbol is shown on the screen. Press the C/R button 4 times to unlock the timer. Once the (a) symbol disappears, you can make changes.



PRESS THE P BUTTON. '10N' WILL APPEAR ON THE LEFT OF THE DISPLAY



USE THE H+ & M+ BUTTONS TO SET THE TIME YOU WANT YOUR LIGHTS TO TURN ON. WE CHOSE 5AM (FOR EXAMPLE).



PRESS THE P BUTTON AGAIN. '10FF' WILL APPEAR ON THE LEFT SIDE OF YOUR DISPLAY



USE THE H+ & M+ BUTTONS TO SET THE TIME YOU WANT YOUR LIGHTS TO TURN OFF. WE CHOSE 11PM FOR THIS EXAMPLE. WE RECOMMEND 18 HOURS ON AND 6 HOURS OFF FOR OPTIMAL GROWTH

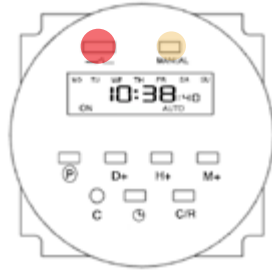

PRESS THE MANUAL BUTTON UNTIL YOU GO FROM 'ON' TO 'AUTO'. THE RED LED LIGHT WILL COME ON WHEN THE LIGHTS ARE 'ON'

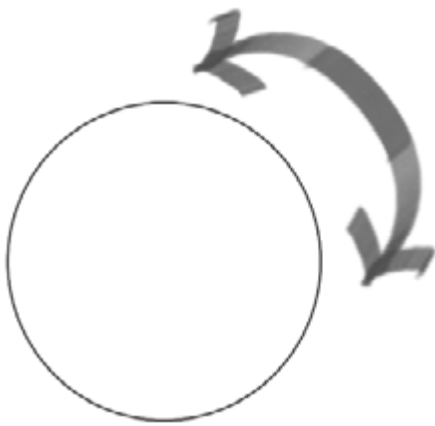

TURN DIMMER ALL THE WAY TO THE RIGHT FOR FULL BRIGHTNESS



4 Planting Seeds

When you order seeds from Just Vertical you are getting the guarantee of seeds that we have tested ourselves. If any of our seeds don't germinate within 21 days we will replace them for free! Seeds are a living thing and sometimes they just don't germinate, so don't worry if a few don't come out right away!

You will use your seedling starter kit to start your seeds.

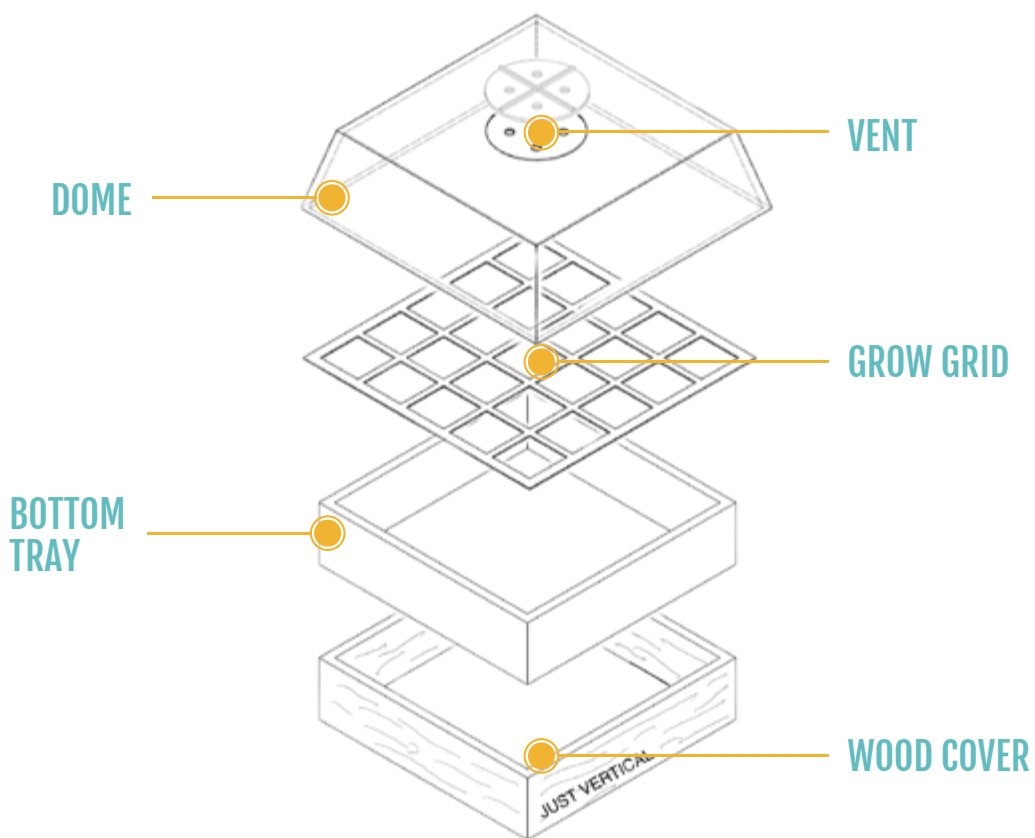

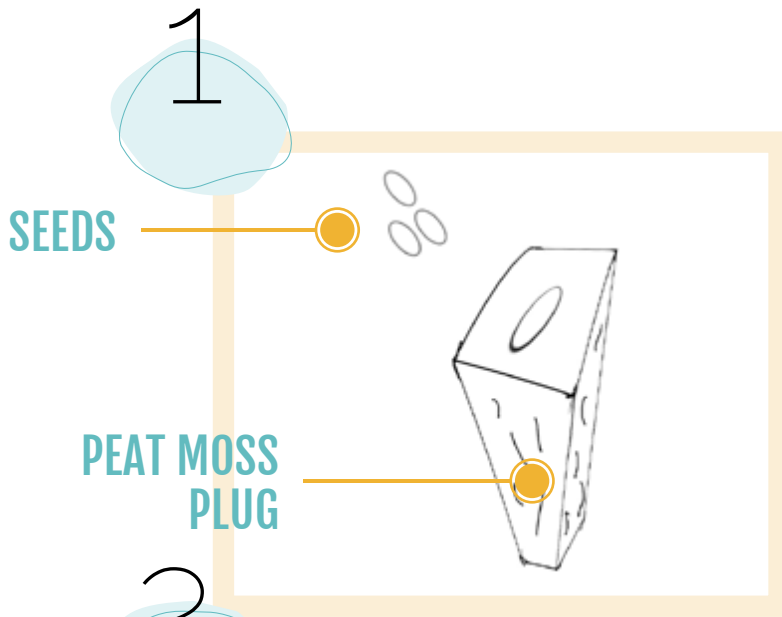

Plant 3-5 seeds per peat moss plug that you've received.

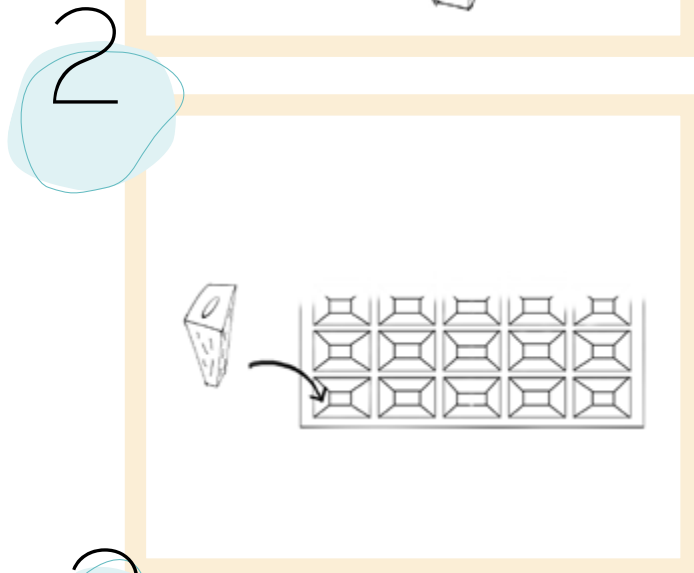

Place plugs with seeds into the black grow grid.

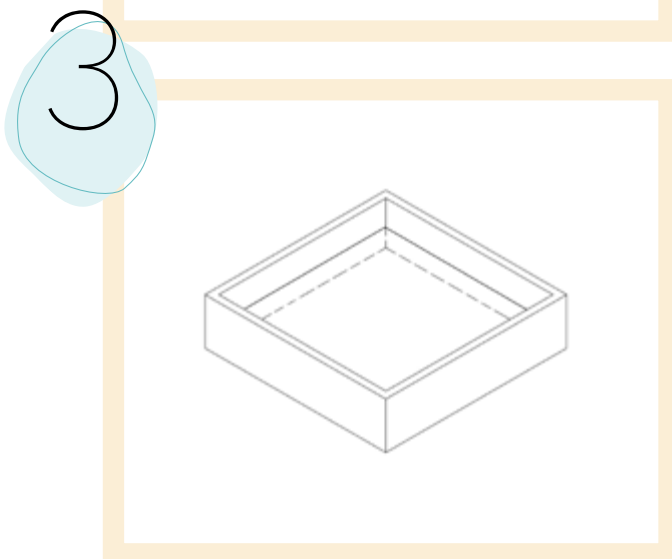

Fill bottom tray halfway with cold water.

Place the grow grid with the peat moss plugs into the water.

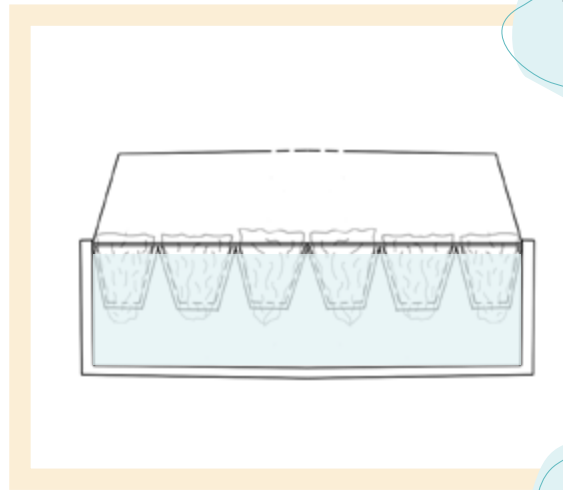

Spray dome with warm water and place on top. Keep vents open.

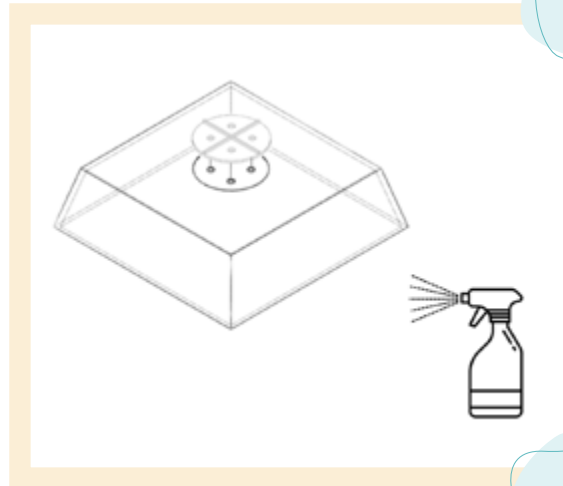

Once plants are touching the top of the dome, they are ready to be transplanted.

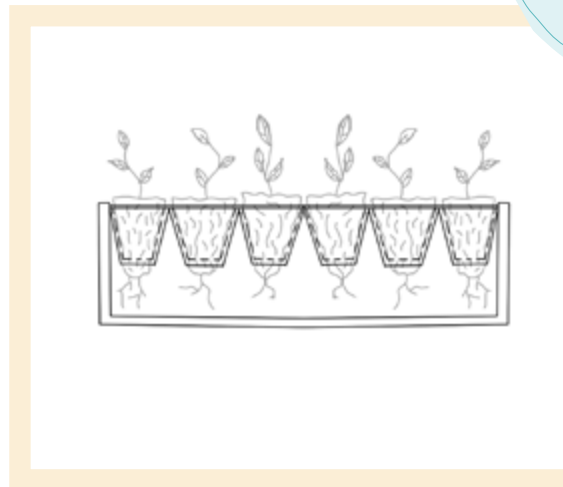

7



Push out seedlings from bottom opening in the grow grid.

8



Place seedlings into the pod in your garden.

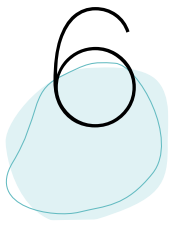

Pump Set-Up & Filling Your Reservoir

Setting Up The Pump

Begin by pushing in the supply pline (clear line) inwards at all connections on the tee.

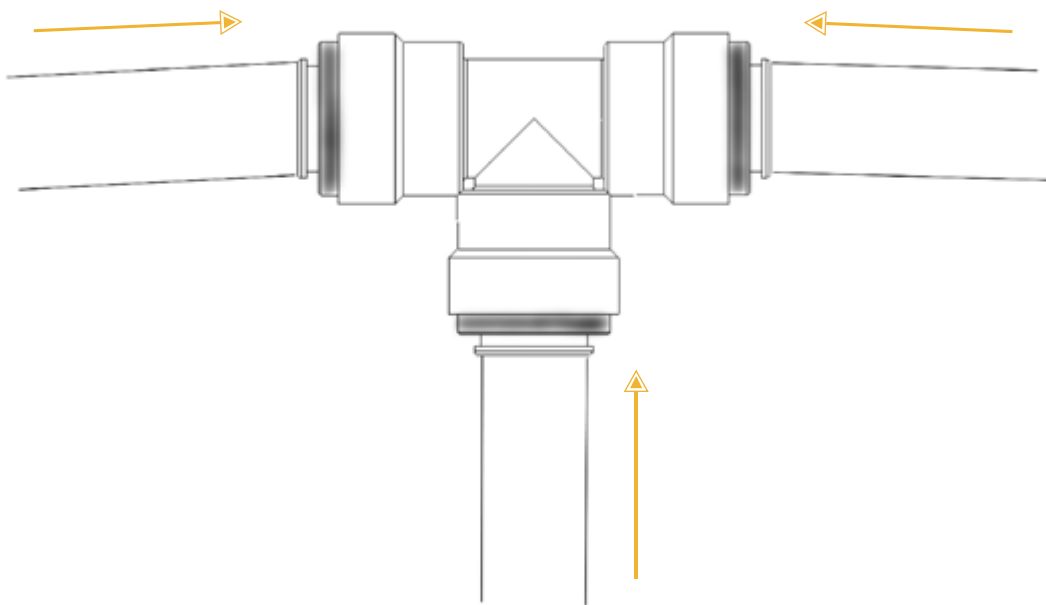

Note: Your pump is pre-set for the irrigation for 20 seconds ON and 30 minutes OFF. This timing never changes.

To set up the pump, take the black timer box and power outlet out of the reservoir. When you fill your reservoir with water, plug in the pump (as shown below).

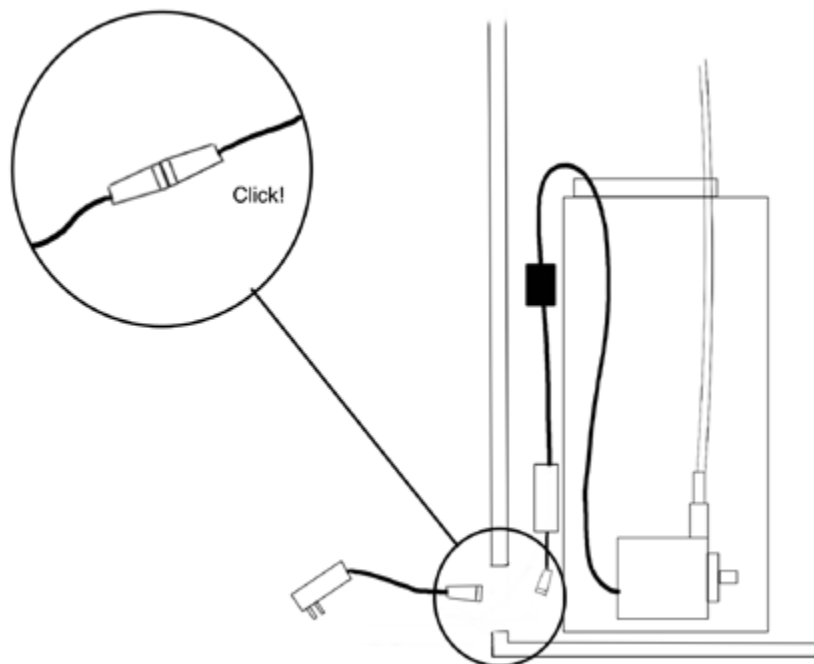
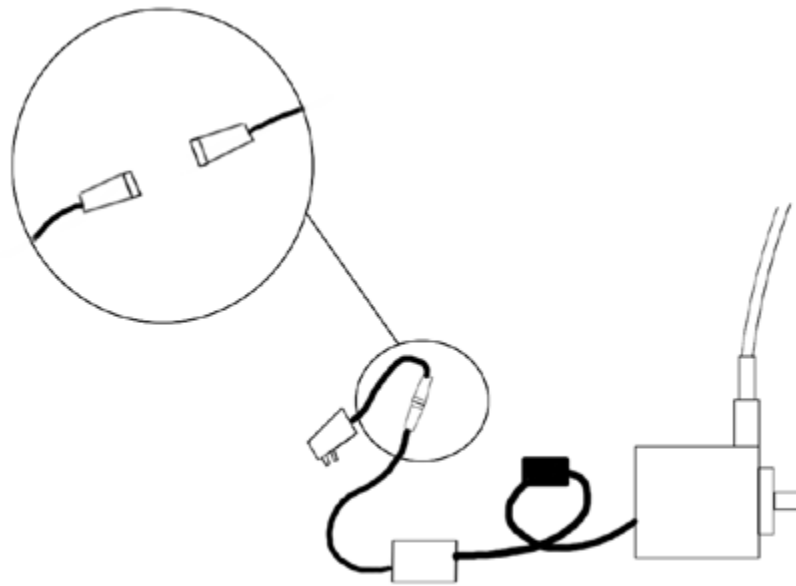

Filling Up Your Reservoir

Before you get started filling your reservoir, make sure you've completed the previous step (setting up your pump).

The reservoir is designed to stay in your unit. Avoid removing the reservoir from where it is housed within the cabinet when you fill it with fresh water.

To fill the reservoir, simply transfer water into the tank through the open hole at the top of the reservoir while it's in the unit.



Reservoir Water Levels

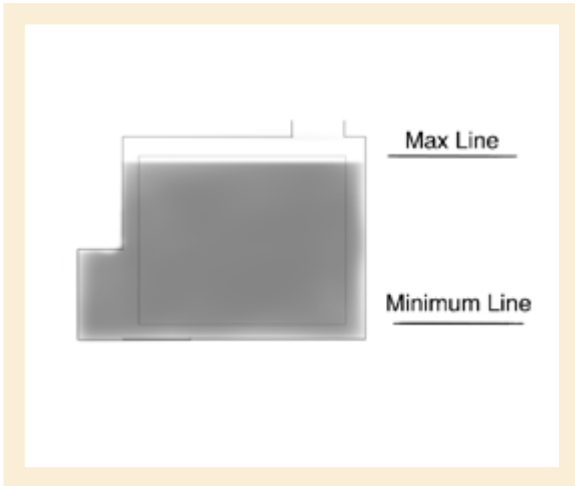

Your reservoir is full. This tank of water will last up to 2 weeks, dependent on plant size. We recommend checking water levels weekly

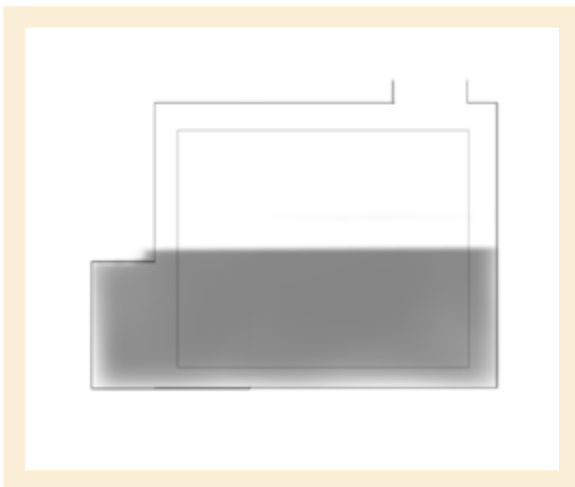

Half-full reservoir. This tank of water will last up to 1 week, dependent on plant size.

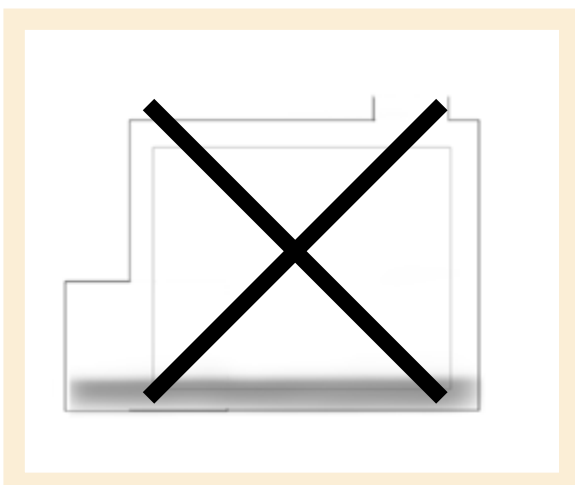

Reservoir is empty. This tank of water needs to be refilled to the original fill line.

Once you've filled the reservoir with cold water, plug the pump power cable into the power bar. The pump should never run without water in the reservoir.

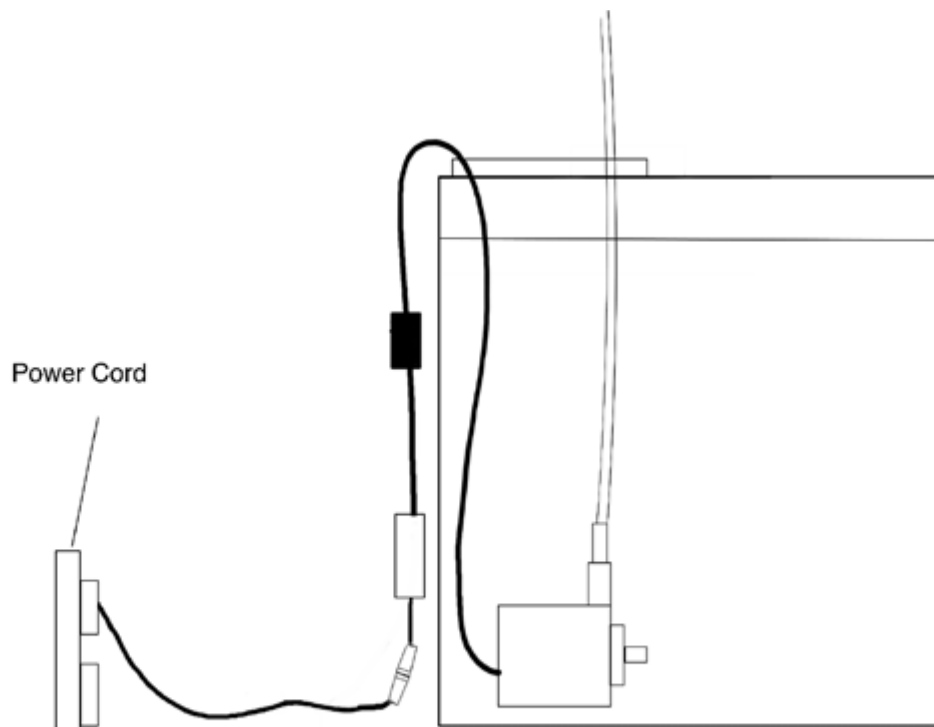

Additional Reservoir Notes

Make sure your Drain Hose is placed inside the reservoir as shown in the image below.

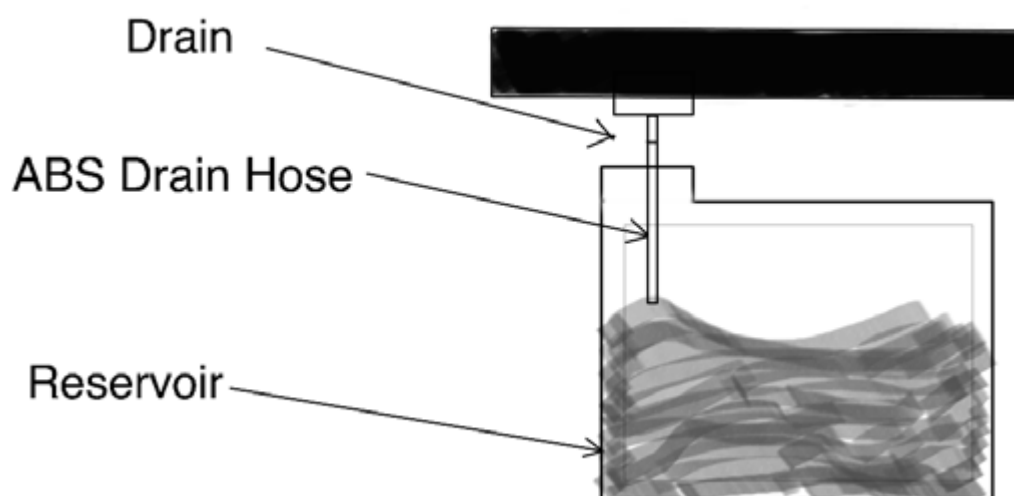

Make sure the supply line is securely attached to the pump.

Make sure you have set-up your EVE according to the instructions above.

If you are missing any parts, or have any questions, or concerns please contact support@justvertical.com

7

Adding Nutrients

Using nutrients is an easy process. If you are starting from a brand new tank of water you put in a little more, if you are just topping up you put in a little less. This is because some nutrients will always remain in the water from last time.

Note: **If you are growing flowering plants** such as tomatoes or strawberries, once the flowers start to bloom, you will start with a fresh reservoir and add 30ml of Flores A and 30ml of Flores B. You will then add 10ml of Flores A and 10ml of Flores B every two weeks.

If you're growing anything else, follow the instructions below.



Within your box, you should receive two bottles of nutrients. 60 mL of Vega A and 60mL of Vega B. Each capful is equivalent to 10mL

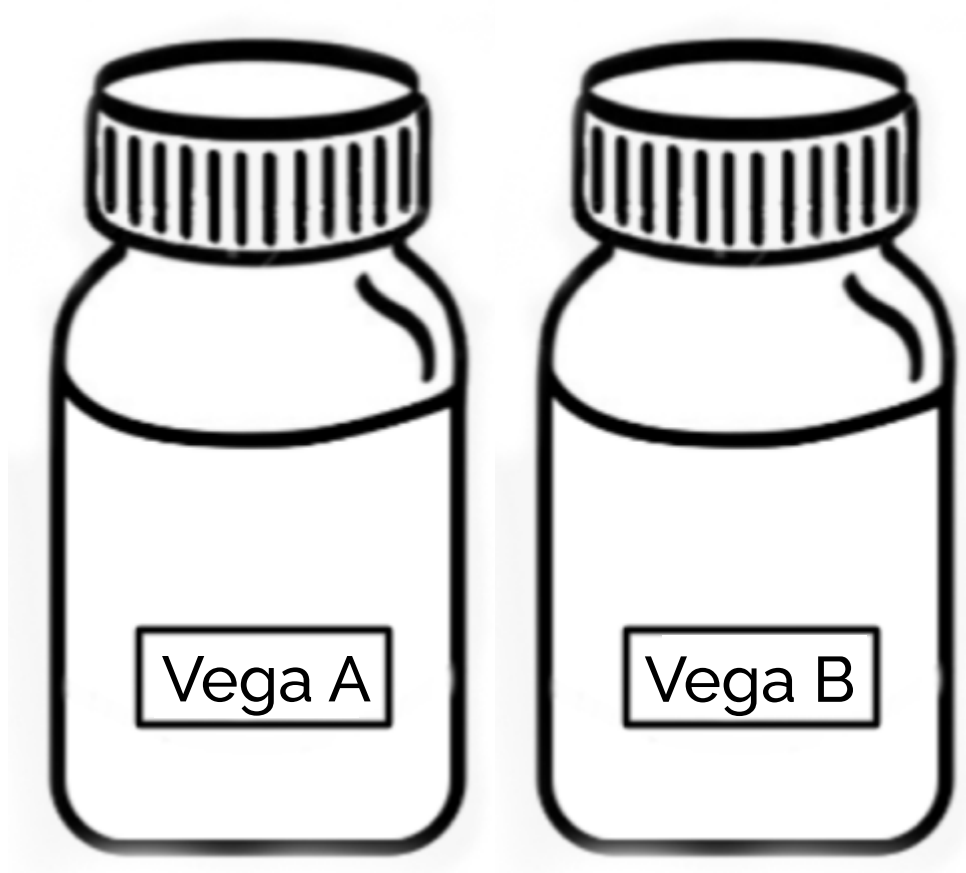

Add 20mL of Vega A and 20mL of Vega B nutrients to the reservoir after you have moved your seedlings from the seedling kit into the EVE. After every 2 weeks inside the EVE, add 10mL of Vega A and 10mL of Vega B.

Common Nutrient Questions

Q: What are the “nutrients”?

A: Nutrients are the basic building blocks of plant life made up of phosphorus, potassium, and nitrogen. These are the same elements you find in garden soil.

Q: How are they made?

A: Our nutrients are a mix of salts placed into water. They are chosen together to provide the best base for plant growth. Each salt is made differently.

Q: Are these natural?

A: Yes, they are quite literally salt of the earth!

Q: Can I store both A & B in one bottle?

A: No you cannot. If you try they will start to bond to each other in the bottles.

Q: How should I store the nutrients?

A: Store your bottles in a dark area at room-temperature

Q: What is the recommended pH for plants?

A: The recommended pH is 5.5 - 6.5.

Q: I am monitoring TDS - what should I aim for?

A: Lettuce & arugula (500-750ppm/1.0-1.5 mS/cm)
Kale and brassicas (600-1000ppm/ 1.2 -2.0 mS/cm)
Herbs (600-800ppm/ 1.2 - 1.8 mS/cm)
Flowering (600-1000ppm/ 1.2 - 2.0 mS/cm).



MAINTENANCE

A Note On Maintenance

Maintenance of your garden is extremely important. Below is a calendar that you can use to keep track of your maintenance tasks. Each specific task is explored in more detail below the calendar.

8 Week Maintenance Schedule

Complete each maintenance task at the frequency stated below to ensure your unit operates at peak performance and to maximize plant health and growth. The cycle repeats every 8 weeks. Once you have completed a task, check off the circle to track your progress.

Week

Check Plants



Check Reservoir



Add Nutrients



Check Roots



Clean Reservoir



Checking Plants

- 1 Pull off any browning or dying leaves
- 2 Harvest consistently when your plants are ready to eat
- 3 Plants larger than 6" should be supported by a stake inserted underneath the plants
- 4 Make sure all plants are properly positioned in their pods.

INCORRECT POSITIONING OF PLUG INSIDE OF THE POD



PEAT MOSS PLUG IS TOO FAR UP



CORRECT POSITIONING OF THE PLUG INSIDE THE POD

Checking Reservoir

Check your water levels and top up on a weekly basis or as needed. Only add nutrients every 2 weeks (as indicated in the manual).

Friendly reminder: even if you added additional water, that does not mean you need to add nutrients as well.

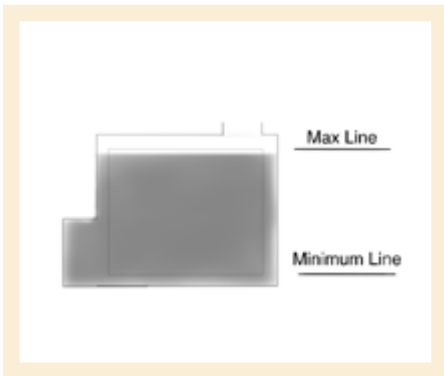

Your reservoir is full. This tank of water will last up to 2 weeks, dependent on plant size. We recommend checking water levels weekly

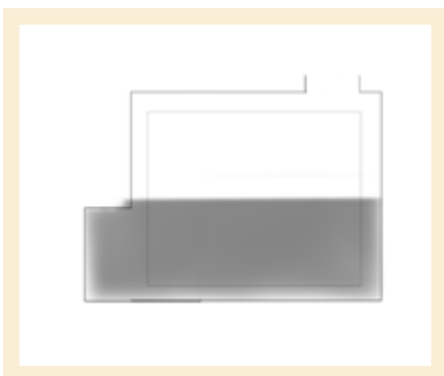

Half-full reservoir. This tank of water will last up to 1 week, dependent on plant size.

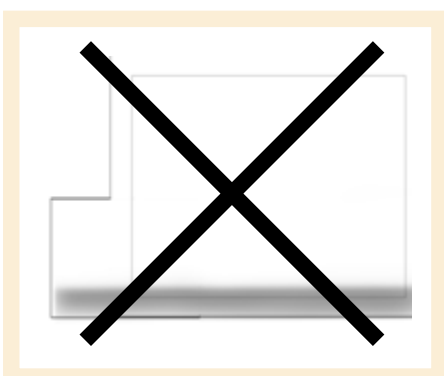

Reservoir is empty. This tank of water needs to be refilled to the original fill line.

Adding Nutrients

Add 10mL of Aqua Vega A and 10mL of Aqua Vega B. Follow the guide in the 'set-up' section for more detailed instructions on filling your reservoir (including FAQs).

Check Roots

Make sure to trim the roots of all the plants at least once a month. By trimming your the roots of all the plants, it allows proper water flow through the unit and reduces any chances of leaks.

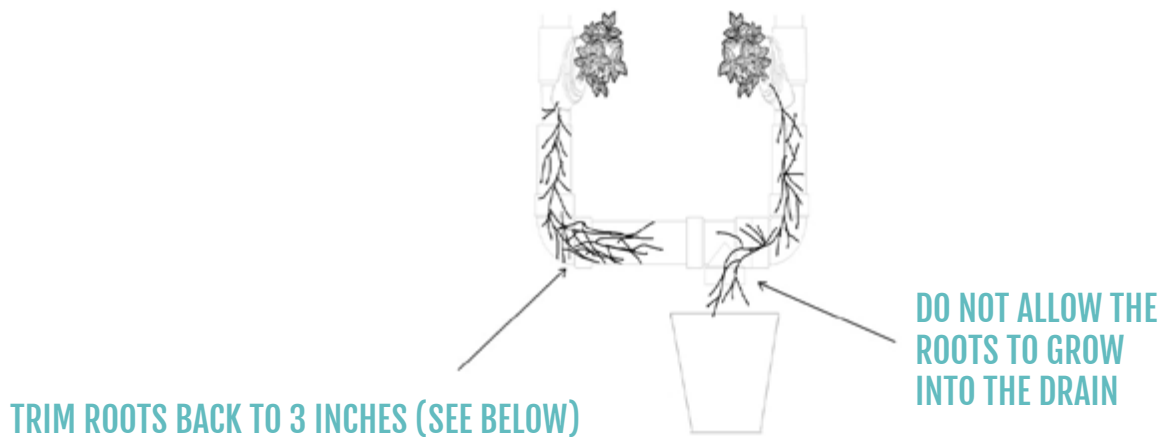

Longer roots will cause a leak in your garden. Make sure to maintain the length of the roots in your garden to 3 inches.

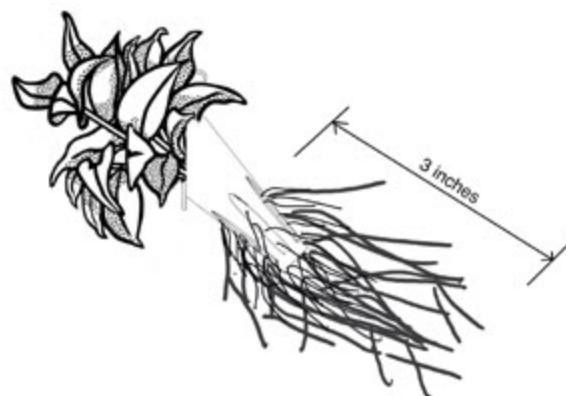

Cleaning The Unit

Reservoir

Wipe off any accumulation of debris or salt buildup from inside of reservoir. If there is any debris in the filter at the bottom of your reservoir, clean that as well.

Unit

Wipe off any debris, splashed water, or nutrient runoff weekly to maintain the visual appeal of your unit.

If you notice there are reoccurring salt stains on the front face of your unit, please check the roots of the plants in your garden. If the roots are longer than the recommended 3 inches, they will cause a small leak in your unit.

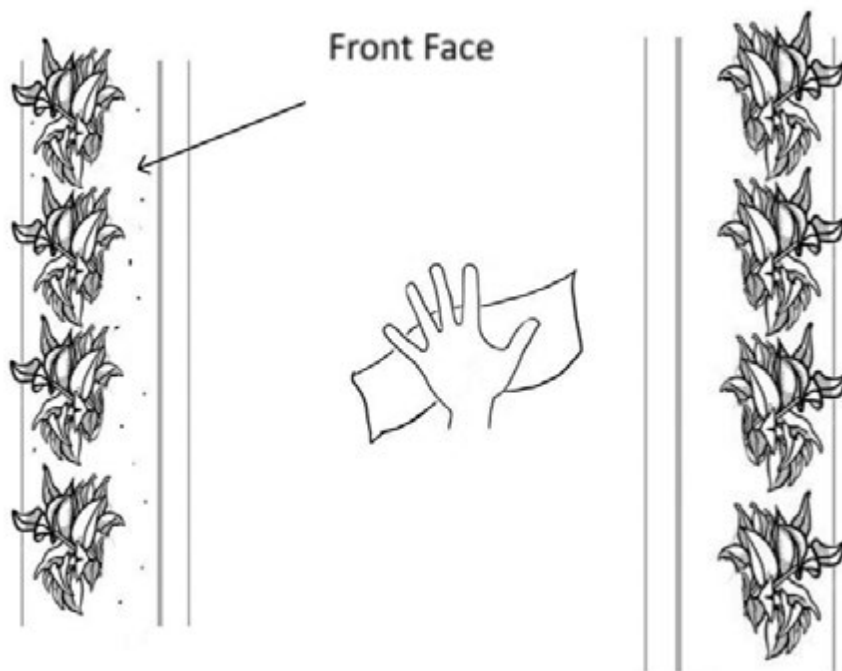

A light blue, irregular, hand-drawn style shape that serves as a background for the title text.

PRUNING, STAKES & POLLINATION

Pruning

Pruning is important to stop plants from overcrowding in your system. It also helps to keep them growing straight and proper. To prune your plants, use clippers, pruners, or your fingers to take off any yellowing or dead leaves (don't worry you will normally get a few of these per plant!). Next, if leaves are growing directly into the light bulbs take those off as they will 'burn'.

Staking

Stakes are used when your plant has grown to about 6" (15 cm) in size. The plant support helps the plants to continue to grow in an upright position and makes sure no water can come out the front face of the EVE. To install the plant stake, slide the stake in between the peat moss plug and the black pod. Then loosely tie the plant to the support..

Pollination

Only flowering plants require pollination. Pollination is how fruits and vegetables are produced from flowers. When you are gardening indoors there are no natural pollinators like bees to move pollen, so you have to improvise! The two common plants that are grown in the EVE requiring pollination are tomatoes and strawberries. To pollinate these you have three options: by hand, vibration, or wind.

To pollinate by hand use a small brush (toothbrush, paintbrush, makeup brush, etc) to move the pollen within the flower from the male to female portion by brushing the middle of the flower then the sides. Vibration pollination works shaking the pod gently so that the pollen comes loose. Wind pollination can be done by setting up a small fan nearby to generate air movement causing the pollen to move around. This should be done once a day for 3 days and then leaving a day of rest before repeating. See below for all the parts of a flower!

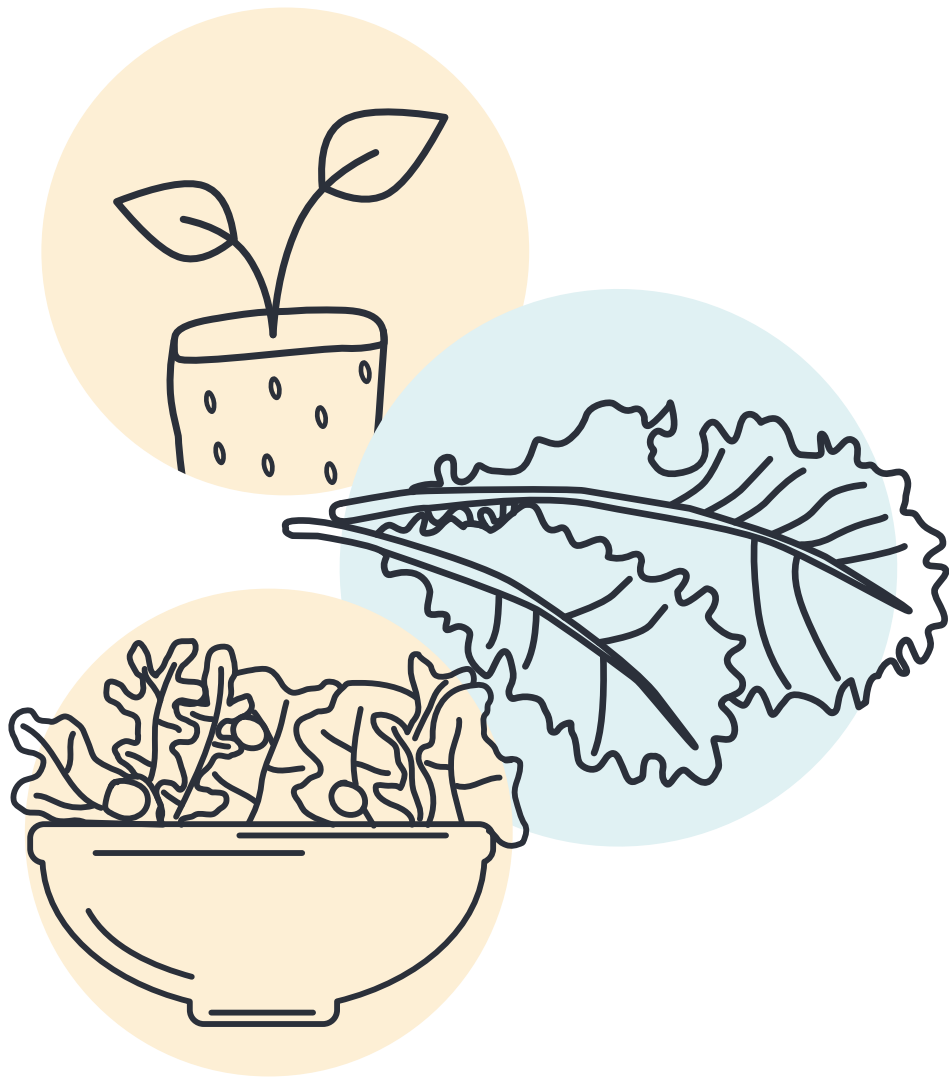



HARVESTING

Common Leafy Greens & Herbs

When harvesting there are three rules to follow:

- 1 Taking more than 1/3 of the plant at once can shock and kill it so be careful.
- 2 If the main stem is going 'woody' then the plant is bolting and it is time for a new one.
- 3 If your plant is growing flowers and the stem is becoming solid wood it is time to replace it.

See below for our guide on when to harvest some popular leafy greens and herbs.

Arugula

Ready to harvest 3-4 weeks after germination. You can harvest continually by taking only a few leaves at once or take the whole plant at once.

Lettuce

Ready for harvest 3-4 weeks after germination. You can harvest continually by taking only a few leaves from the outside or you can take the whole plant at once.

Kale

Harvested by leaf starting with the leaves closer to the base of the plant.

Spinach

Harvested as baby spinach for a softer flavour in which case you can harvest by leaf. However, if you want mature spinach, take the whole head at once.

Basil

Harvested many times throughout its life and responds well to being trimmed. Cut basil from the top canopy of the plant to encourage fuller growth.

Mint

Tends to get fresher the more it is harvested. Continually harvest once it is 3 or more inches long. Trim it from the base making sure to leave it about 2 inches of growth.

Cilantro

(also known as coriander) Ready to harvest when it is 6 inches tall. To harvest just pick off what you need or cut off a bunch at once. Enjoy the fresh tacos!

Rosemary

Slightly slower growing herb that is ready around 6 weeks of growth. Each time you harvest you can take about 2 inches off each branch.

Dill

Takes around 8 weeks to fully develop. should be regularly pruned as it grows. To harvest cut the stalks from the outside in and as close to the base of the plant.

Parsley

Takes around 10 weeks to fully develop. Should be regularly pruned as it grows. To harvest cut the stalks from outside in and as close to the base of the plant.

Harvesting Strawberries & Tomatoes

Cherry Tomatoes

Cherry tomato plants take a bit more care and patience throughout their life cycle. These plants generally take 6- 8 weeks before producing ripe tomatoes.

Throughout the growing process you will want to regularly prune the plant cutting back some of the excess foliage. This will encourage the plant to produce tomatoes.

When pruning you should look for suckers that should be taken off - these grow out of the elbow of the main stem and its branches. The flowers you see will eventually become tomatoes so make sure to take good care of them! When flowers emerge switch your light cycle to 12 hrs on/ 12hrs off.

Make sure to regularly pollinate the flowers and soon you will see green tomatoes. You will know they are ready to harvest when they turn to a bright red colour.

Strawberries

Strawberries can sometimes be a test of your patience. These plants can take several months (or even longer) before they begin to produce fruit.

Fortunately, once established strawberries can continue to produce fruit for a very long time!

With strawberries as soon as you see flowers ensure that you are regularly pollinating them and that you are using the Flores nutrient blend and you change your light schedule to 12hrs on/12 hrs off.





TROUBLESHOOTING

Troubleshooting – Hardware

Despite our best efforts, sometimes things can still go wrong with your unit. Don't fret. Here are some frequently used troubleshooting steps that will help you get your unit back to running in no time.

There Is No Water Being Delivered To The Plants

- 1 Try pressing the 'reset' button on your GFCI.
- 2 Is the water in the reservoir covering the pump while it's running?
- 3 Is the pump plugged into the power bar?
- 4 Are the black quick connect power cables for the pump and its timer properly connected to each other?
- 5 Check there is power to that outlet in your home.
- 6 Try turning the system off for 5 minutes and then turning it back on.
- 7 Check that the supply line is connected to the pump.

Leaking From The Pods Onto Front Face

This can be noticed by salt stains (white streaks) on the front face of the unit. This is caused by two main things:

- 1 Large plants
- 2 Plants with large root mass

Trimming your roots on a regular basis also helps you grow healthier plants with more nutritional content.

If your plants are ready for harvest, take them out of your EVE and plant a new set of seeds.

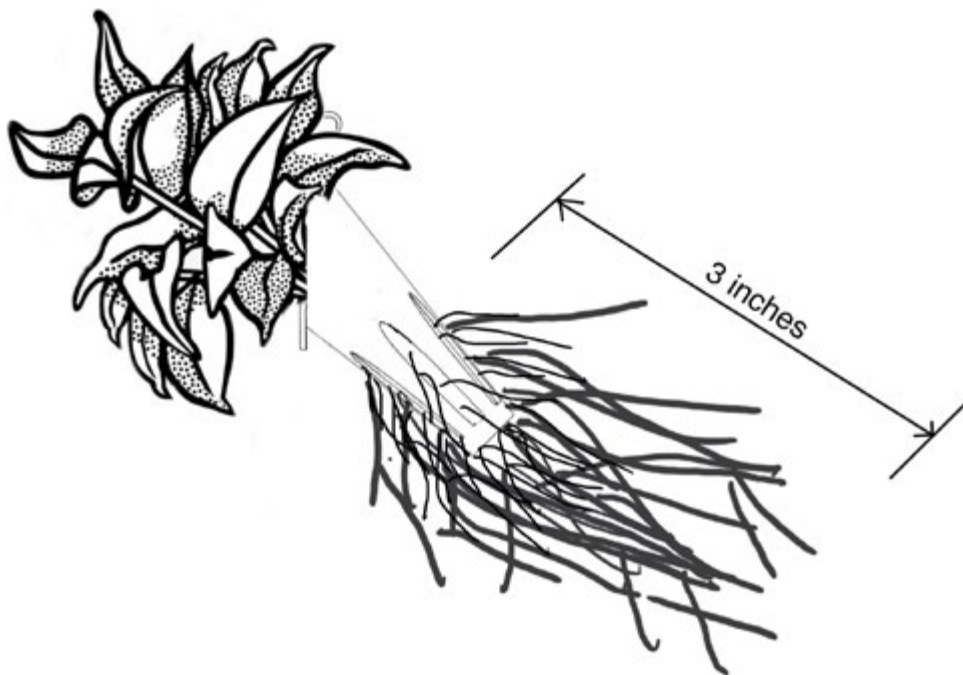

LONGER ROOTS AS WELL AS "RAPUNZEL-LIKE" ROOTS WILL CAUSE A LEAK IN YOUR EVE. MAKE SURE YOU MAINTAIN THE ROOTS IN THE EVE.

Leaking From The Bottom Plant Site

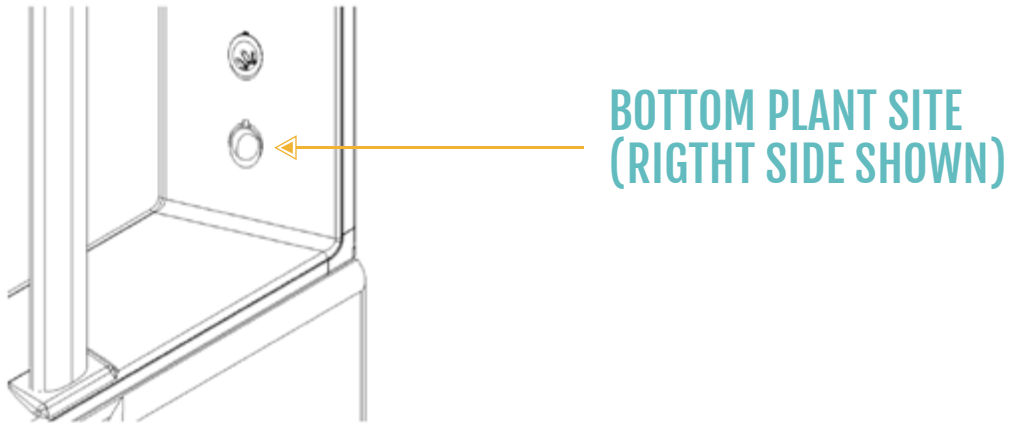

This is caused by very large root mass in the bottom plant sites of the unit, or any debris that may have found its way into the unit. When roots or debris block water flow back into the drain, the water will be forced out from the bottom pods. If after trimming the roots the drain is still blocked proceed to the blockage in the supply line or drain troubleshooting.

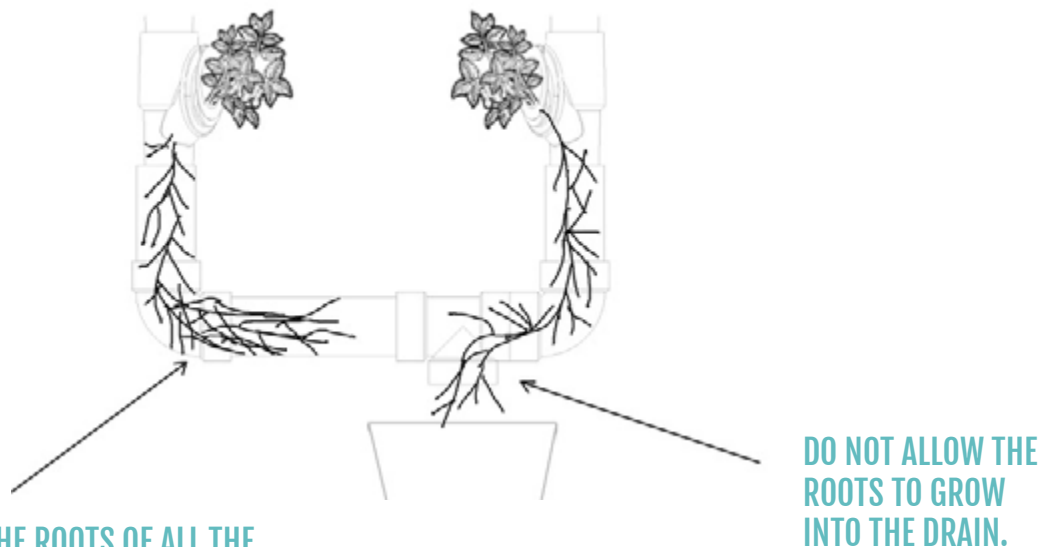

MAKE SURE TO TRIM THE ROOTS OF ALL THE PLANTS AT LEAST ONCE A MONTH. BY TRIMMING THE ROOTS OF YOUR PLANTS, IT ALLOWS PROPER WATERFLOW THROUGH THE UNIT AND REDUCES ANY CHANCES OF LEAKS

Water Is Leaking From An Inside Pipe

- 1 Check the supply line is securely in the tee.
- 2 Check that the reservoir is directly underneath the black drain pipe.

No Power To The Timer

- 1 If you can't see anything on the timer display, check the power cord is plugged in to the timer box and the power bar is on.
- 2 Verify the power bar has electricity by plugging something else into it (or checking the pump is running).
- 3 If there is still no power, try pressing the switch on the power bar and the reset button on the GFCI.

Light is Flickering

- 1 Check that the plug into the timer box are firmly inserted.
- 2 Try turning the dimmer up and down.

Plants Not Receiving Enough Water

The EVE is designed to water all plants evenly. However, sometimes certain plants can get more water than others. This could be caused by:

- 1 Improper plant arrangement
- 2 Blockage in the supply line or drain

These issues can easily be resolved. Practice proper plant arrangement for optimal waterflow with larger plants at the bottom and smaller plants at the top (as seen below)

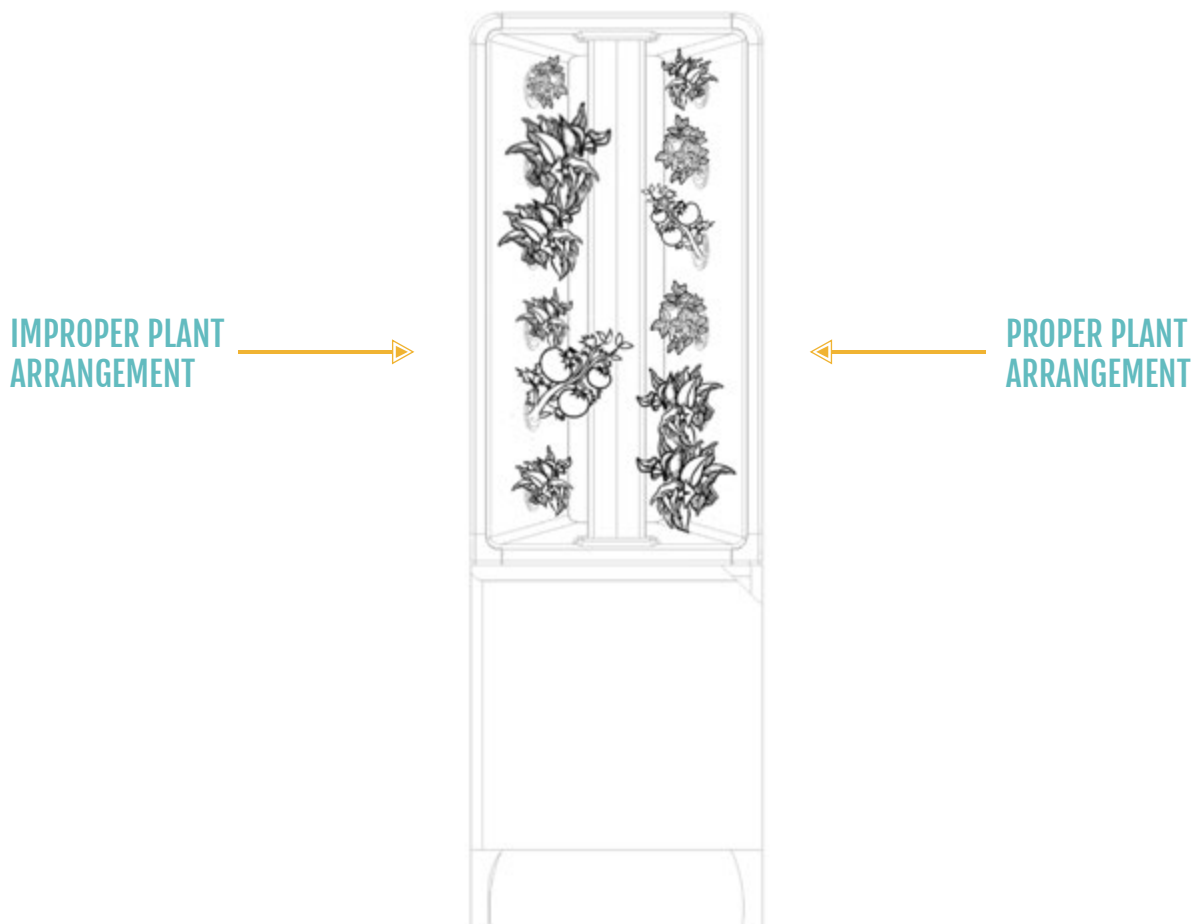

Blockage In The Supply Line Or Drain

1

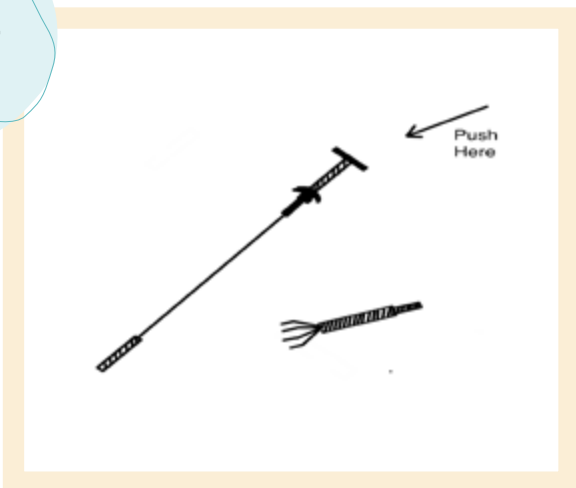

Remove the bottom pods and utilize the quick grab tool to grab roots that may be stuck in the drain and other debris.

2

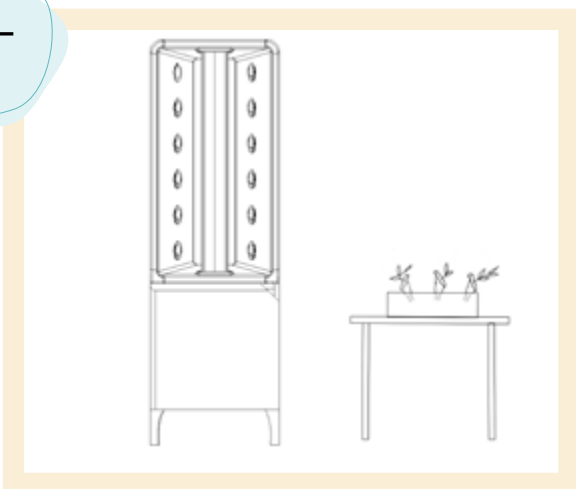

Remove ALL your plants from your unit and place the plants in a container filled with cold water.

3

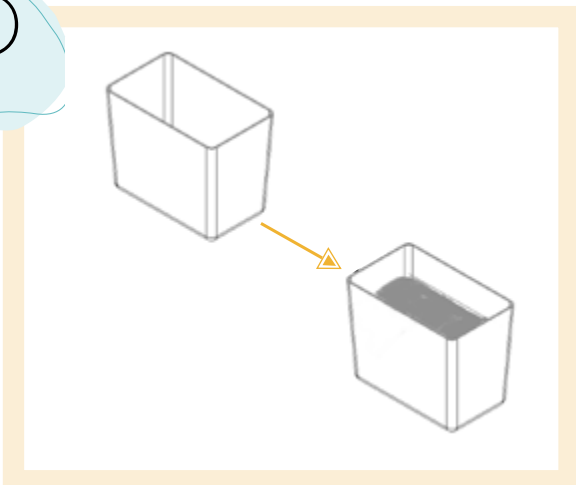

Empty the reservoir. You can save the nutrient water in another container for re-use or pour it down the sink.

4

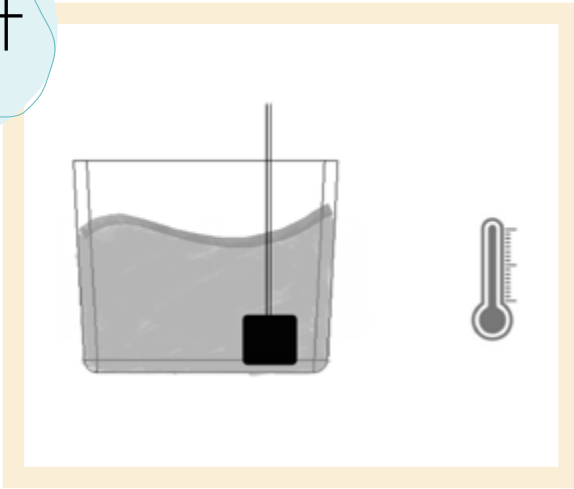

Fill the now empty reservoir with warm water.

5



Add 60mL of hydrogen peroxide.

6

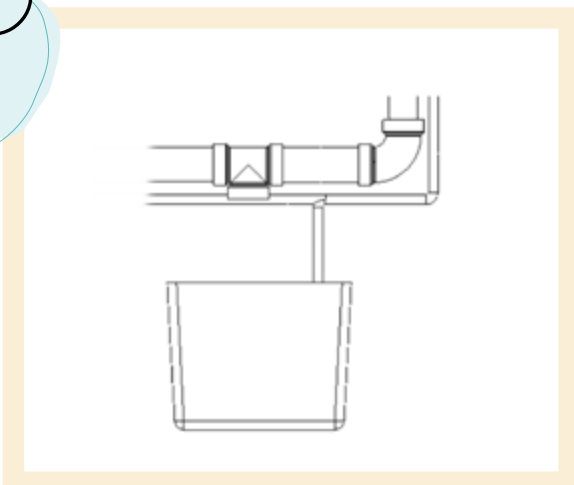

Make sure the drain is directly above the reservoir to allow your EVE flush properly.

7

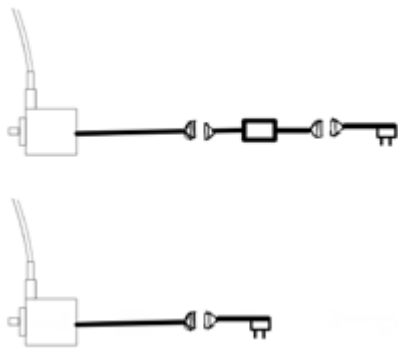

Allow the pump to run continuously for 15-20 minutes. You can achieve this by disconnecting the black box from the pump.

8

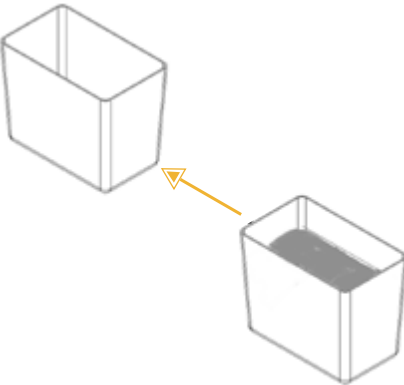

After allowing the pump to run, unplug the pump and reconnect the black box. Rinse out the reservoir and the pump. Return the nutrient water back into the reservoir and the pods back in the EVE.

9

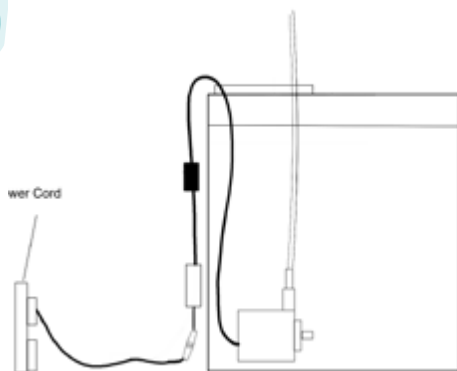

Plug the pump back into the power cord and you have now completed the descaling process.

Timer Troubleshooting

Is the timer locked? Is there a backward 6 displayed (⌘) on the left side of the LCD display of the timer?

You will need to press the C/R button 4 times to unlock the timer and the backward 6 will disappear.

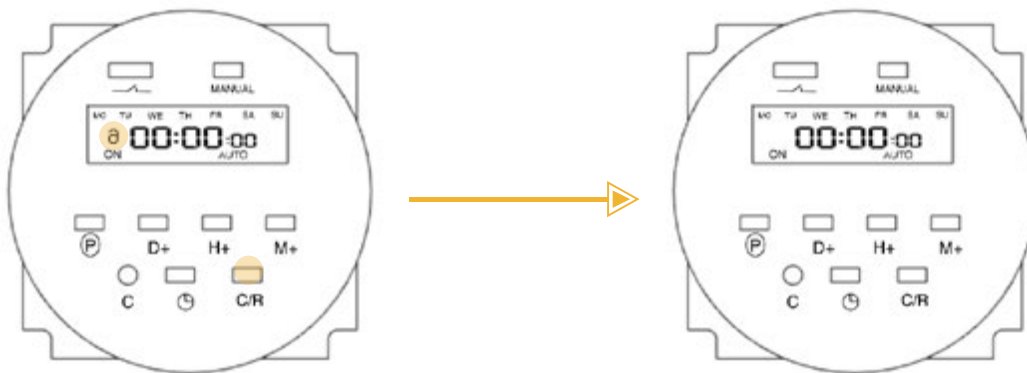

Press the manual button twice to ensure that the timer is switched to 'ON'. The red light will come on when the timer is on 'ON'.

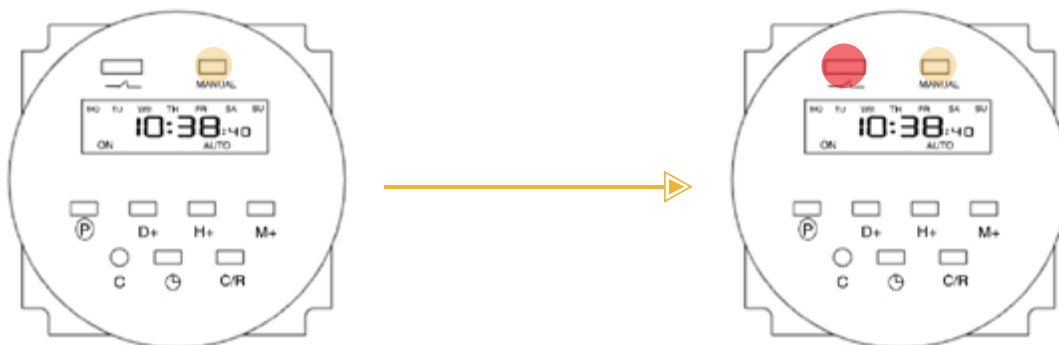

Do the lights work now? If yes, press the manual function one more time to go to 'AUTO' on the LCD display. The issue has been resolved.

If no, please contact us at: support@justvertical.com

Troubleshooting – Pests

Pests, though rare, can happen in indoor gardening. These are easily solved with some common household items.



Aphids (white & green peach)

These aphids eat leaves and suck sap from the stem. They are visible throughout their life cycle. They can be found laying their eggs on wet roots or other plant material. They are usually found on the underside

of leaves or stems. In nature they are controlled by ladybugs or aphidoletes. In your home you can remove them with a natural dish soap and warm water. Spray the affected areas and let sit for 15 mins then wipe off the plant. Alternatively, you can spray with an insecticide.

Fruit Flies & Fungus Gnats

These flies like to lay their eggs in dark, wet conditions. They are only visible in the adult stage of their lives when they are flying around plants. They like to eat dying leaves to be sure to prune your plants to avoid them. They are best controlled with

a nematode spray which is prepared by soaking a nematode sponge in warm water and then spraying directly on and around the plants. Alternatively, an insecticide can be used or yellow sticky traps can be placed to catch them. To avoid more of them make sure to sterilize and wipe down the face of the unit.



Spider Mites

Spider mites cause leaves to look yellow or bronze in colour. These are typically controlled in nature by other mites. Spider mites are commonly found in dusty conditions, keeping humid clean

air helps prevent them. To control spider mites use a natural dish soap and let sit on the leaves for 15 minutes before wiping them off. Alternatively, you can spray with an insecticide.

Algae and Mold control

To avoid algae or mold wipe down all front faces of the EVE and around the pods to limit algae growth. Algae likes to grow in cold wet conditions and in warm water.

Troubleshooting – Plants

Are your plants growing slower than expected? There could be one or more issues affecting this. First make sure your expectations are reasonable and in line with what plants are capable of (our system is amazing but not a miracle worker).

Here's a list of the most common issues we find

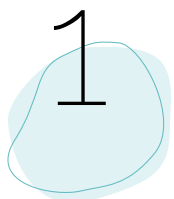

Nutrients

Having too high a concentration of nutrients in your reservoir can cause tip burn on your plants. This is exhibited by browning or yellowing of the leaves. It could also cause wilting or weakening of the plant. If a large quantity of nutrients were accidentally added to your reservoir it is recommended that you empty your reservoir and add fresh nutrients.

Nutrient deficiencies can be indicated by poor plant health. Indicators of these could be plant wilting, yellowing of leaves, browning of leaves, etc. Please refer to the nutrient section for correct dosing.

2

Temperature

If your plants are exposed to extremely hot or cold air (under heating vent or next to a door in the winter) this could be stunting plant growth.

3

Air Flow

If your plants are not getting any air flow this can also stunt plant growth, ensure there is adequate air flow around your plants.

4

pH Levels

If you are running your EVE on well water or otherwise irregular water test the pH level of the water source. A pH outside of the normal range could negatively affect your plant growth. Heavy metals in the water especially can stunt growth.

THANK YOU!

WE'RE LOOKING FORWARD TO GROWING
WITH YOU