

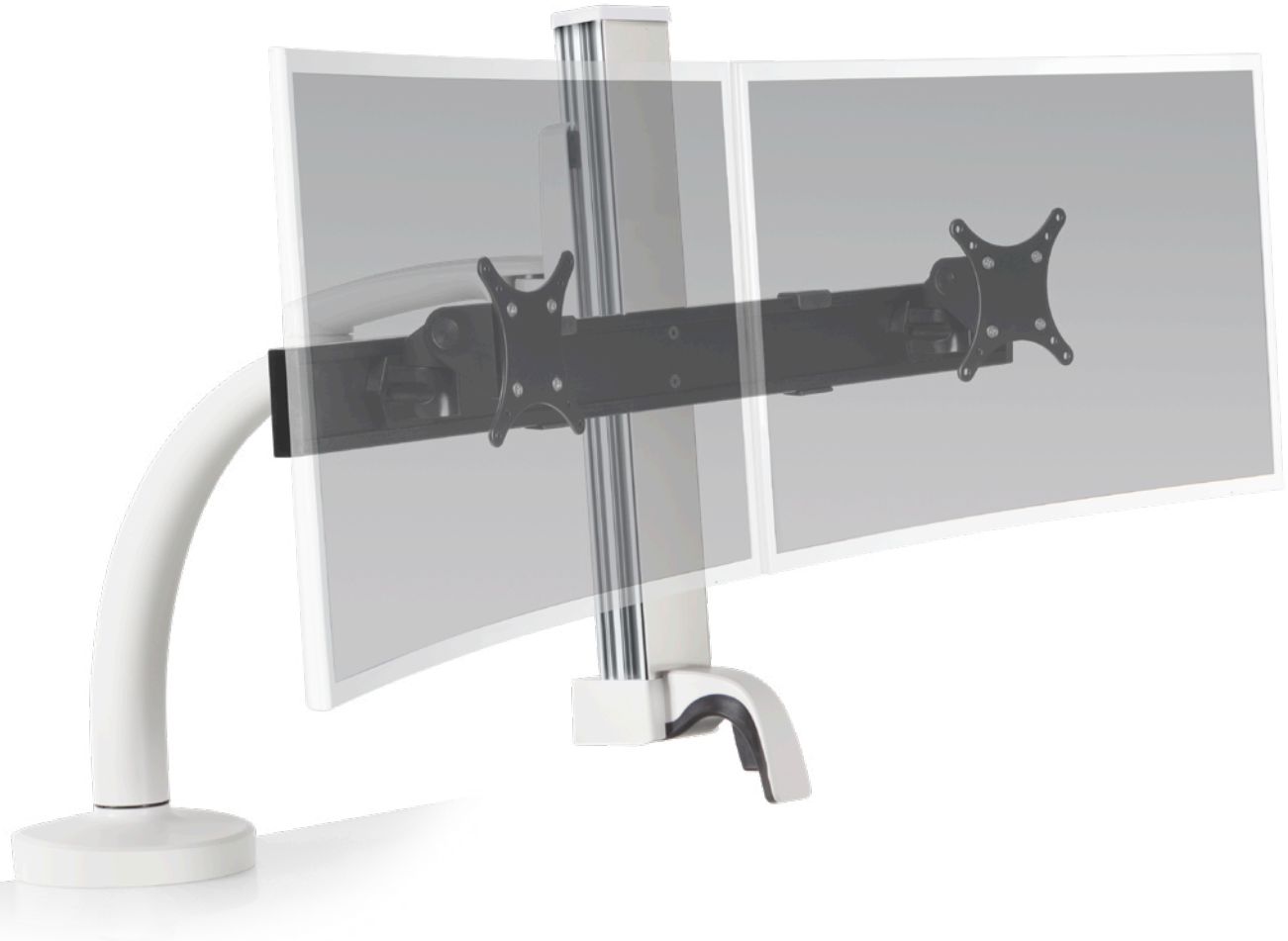

# DUAL ELLA

Featuring our dual monitor beam, Dual Ella allows you to work the way you want without sacrificing style.



### FEATURES

- Integrated handle allows for effortless monitor movement.
- Mount installation is performed above desk for quick and easy set-up.
- Easily rotate flat panel monitor for portrait or landscape viewing.
- Built-in 180 degree rotation stop at the base of the arm.
- Supports two monitors with a screen size up to 30".
- VESA-monitor compatible – 75mm & 100mm VESA adapters included.
- Optional customization options available to complement any workspace, contact your rep for details.

### AVAILABLE OPTIONS

**ELLA-2-CM** Supports 2 - 15 lb (0.9 - 6.8 kg) per monitor

### FINISHES

FLAT WHITE | color code: **248**

SILVER | color code: **124**

VISTA BLACK | color code: **104**



CAPABILITIES

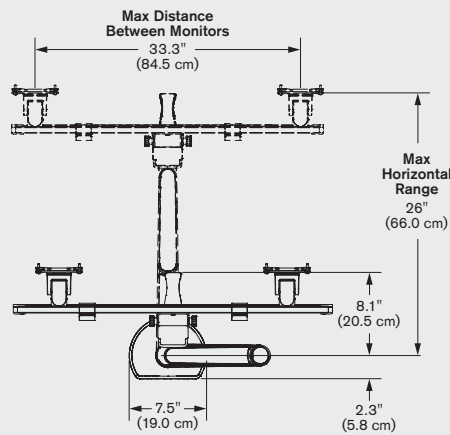
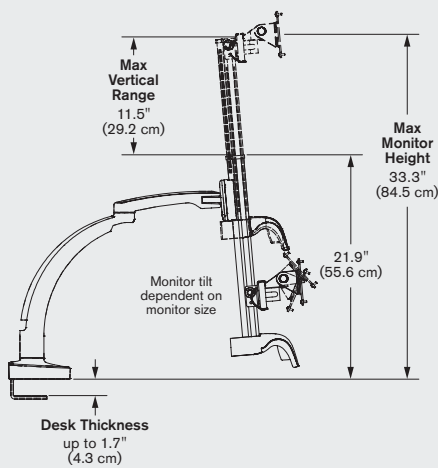

MOUNT CONFIGURATIONS



Desk Edge

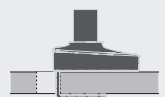

Grommet