

# HÅG Capisco & HÅG Capisco Puls

INS-P8000-R3-PAC

## ASSEMBLY INSTRUCTIONS

9to5<sup>®</sup>  
seating

### PARTS

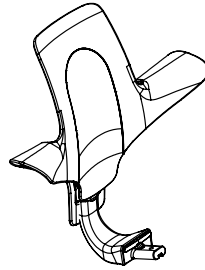

Back (x1)

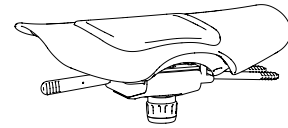

Seat (x1)

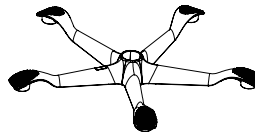

Base (x1)

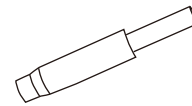

Cylinder (x1)



Casters (x5)

### TOOLS



Allen Wrench (x1)  
(attached to the bag with casters)

### HARDWARE

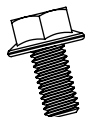

Bolts (x1)  
(attached to the mechanism)

All parts come pre-attached in the back and/or seat.  
Missing parts or hardware? Call 888.925.SEAT

### STEP 1

Attach the casters and cylinder to the 5-star base.

**1A.** Firmly press the stems of 5 casters into the 5 holes in the base.

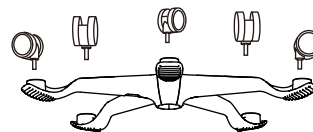

**1B.** Insert cylinder into the center hole.

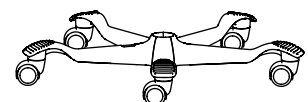
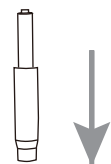

## STEP 2

Attach the back to the seat.

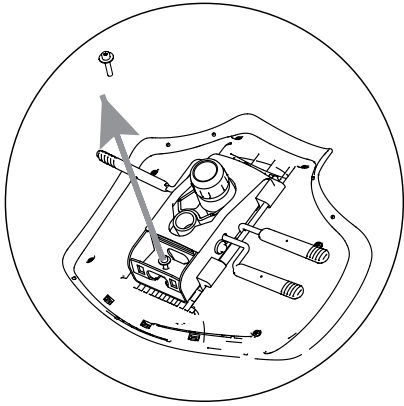

**2A.** Using the Allen wrench, remove the single bolt from the mechanism.

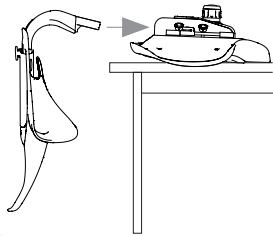

**2B.** Place the back plate under the seat as shown.

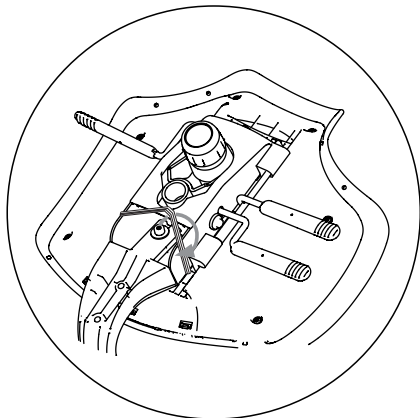
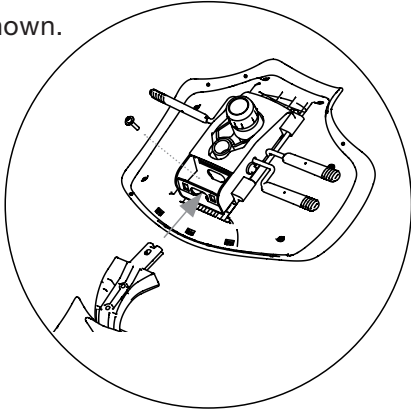

**2C.** Using the Allen wrench, tighten the bolt from the top.

## STEP 3

Join the back and seat with the cylinder and base.

Insert the assembled back/seat unit onto the cylinder, which was placed in the base in Step 1. Press down firmly to secure.

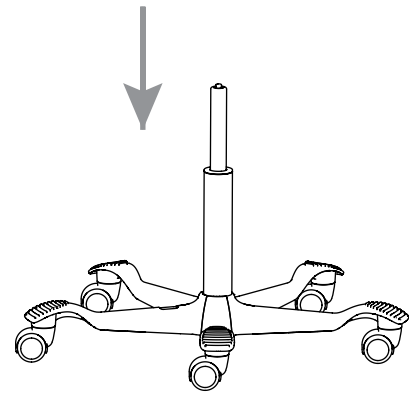
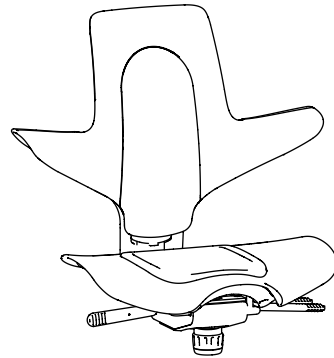

# HÅG Foot Ring

HÅG Capisco and HÅG Capisco Puls  
INS-P8000-FTR

## ASSEMBLY INSTRUCTIONS

9to5<sup>®</sup>  
seating

### PARTS

Missing parts or hardware?  
Call 888.925.SEAT

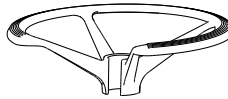

Footring (x1)



Sleeve (x1)



Spacer (x1)

### Standard Height Foot Ring

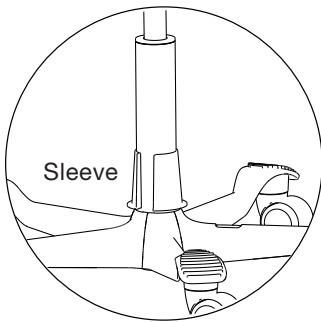
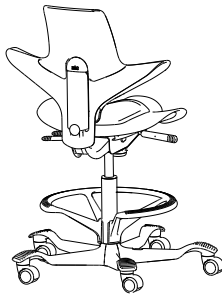

Sleeve

**1.A** Attach sleeve at  
narrow part of cylinder

**1.B** Slide down so sleeve  
rests at top of base

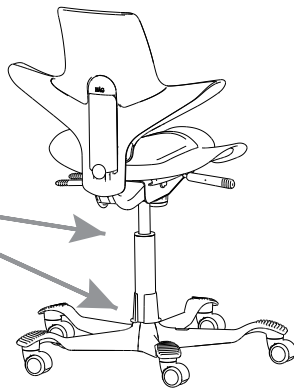

**2.B** Attach foot ring  
at narrow part of cylinder

**2.B** Slide down over  
sleeve to secure

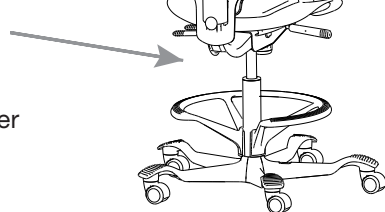

### Elevated Height Foot Ring

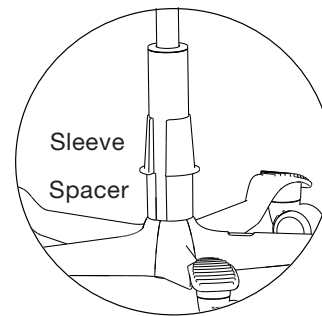
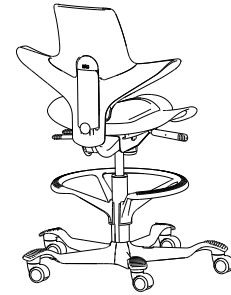

Sleeve  
Spacer

**1.A** First attach spacer at  
narrow part of cylinder, slide  
down so it rests at top of base

**1.B** Next Attach sleeve at narrow part of cylinder  
and slide down so it rests on top of spacer

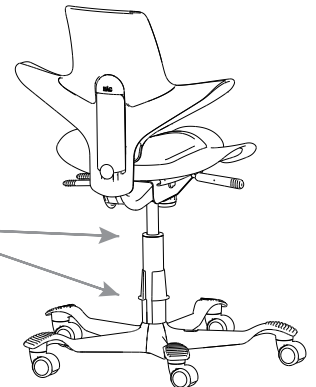
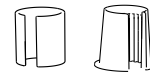

**2.B** Attach foot ring  
at narrow part of cylinder

**2.B** Slide down over  
sleeve to secure

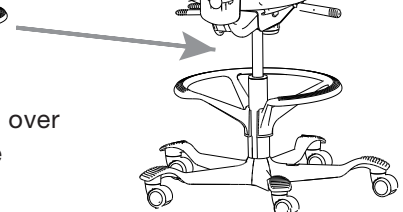



**PHONE** 888.925.SEAT **FAX** 866.925.SEAT **EMAIL** [sales@9to5seating.com](mailto:sales@9to5seating.com) **9to5seating.com**  
3211 Jack Northrop Ave. Hawthorne, CA 90250

©2021 9to5 Seating