

## Combi steamer

### FlexiCombi®

Gas combi steamer FlexiCombi® Classic 10.1

MKN-No.: FKG COD115C



world of cooking

### Features

- Analogue setting and digital display for cooking temperature, humidity, cooking time and core temperature
- **Manual operation concept** with 6 cooking modes: SoftSteaming, Steaming, ExpressSteaming, Convection, CombiSteaming and Regeneration
- 100 cooking processes can be saved
- Cooking Steps function – up to 6 programme steps can be individually combined
- **FlexiRack** – capacity concept for an increase in capacity up to 100% \*
- **EasyLoad** – **crosswise insertion supplied as standard** for increased occupational safety
- **DynaSteam** – dynamic process-oriented steam quantity adjustment depending on product load
- Dynamic autoreverse fan for extremely uniform cooking results
- 5 fan speeds programmable
- Fan safety brake
- Integrated grease separation system
- **Hygienic cooking chamber door with sealed triple glazing**
- Right hand hinged door
- **Hygienic cooking chamber** of corrosion resistant stainless steel
- **ClimaSelect** – Climate control in steps of 25 %
- **Ready2Cook** – preheating, cooling down, climate preparation
- Internal core temperature measurement (up to 99 °C)
- MFB digital forced air burner technology

### Accessories

- Hanging rack for crosswise insertion, standard configuration, 10 shelf inserts for GN 1/1 and FlexiRack, with tilt protection for containers, distance between insert levels 68 mm



FKG COD115C

### Option

- **WaveClean** – automatic cleaning system, siphon is included with the appliance
- **Integrated shower hose**
- Left hand hinged door
- Two position safety door lock
- Internal multipoint core temperature probe
- Connection for external multipoint core temperature probe (cannot be retrofitted)
- Prison version
- Special voltage

### Product safety



\* compared to GN 1/1

Combi steamer  
**FlexiCombi®**  
 Gas combi steamer FlexiCombi® Classic 10.1  
 MKN-No.: FKG COD115C



world of cooking

FKG COD115C

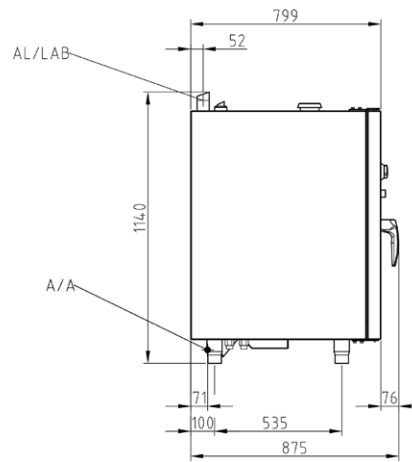
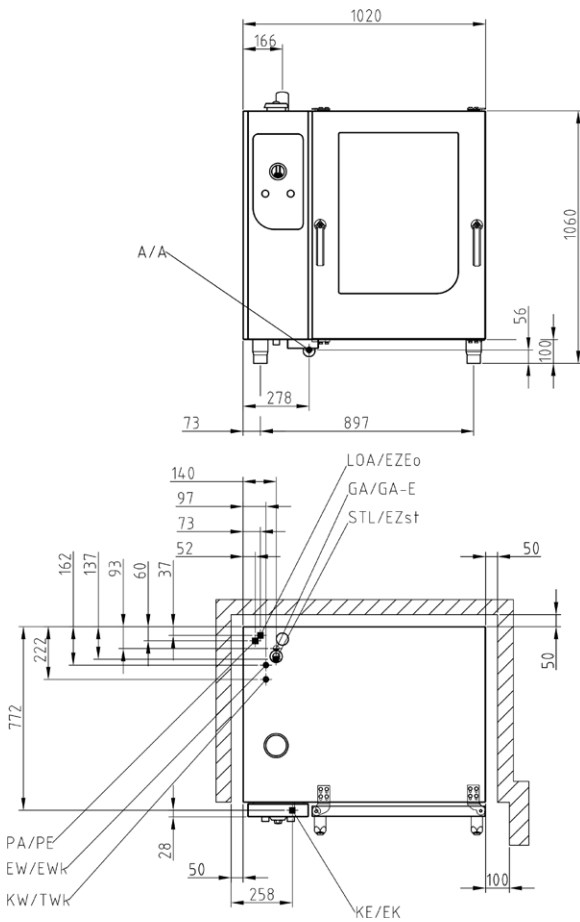

Please find detailed information at  
[www.mkn.com/en/login](http://www.mkn.com/en/login)

## General installation interfaces

### Interfaces provided on site

- Electricity connection (EA/EZ)
- Gas connection (GA/GA-E)
- Connection to cold water mains (KW/TWk)
- Soft water (EW/EWk)
- Waste water connection (A/A)
- Exhaust air (AL)

<b>Appliance dimensions (LxWxH) (mm)</b>	1020 x 799 x 1060
Housing material	1.4301
Dimensions incl. packing (LxWxH <sup>2</sup> )(mm)	1020 x 1220 x 1350
Net weight (kg)	155
Gross weight (kg)	175
max. load weight (kg)	80
<b>Installation instructions; safety clearance in mm</b>	
at the rear	50
left and right respectively	50
recommended clearance for service purposes	500
when the rack trolley is parked on the left	800
Clearance to heat sources on the left	500
Clearance to deep fat fryers on the left and right respectively	at least the length of the hand shower

Combi steamer  
**FlexiCombi®**  
 Gas combi steamer FlexiCombi® Classic 10.1  
 MKN-No.: FKGCOD115C



world of cooking

FKGCOD115C

Capacity	
Quantity of cooked food (kg)	10x 15
Shelf inserts	10
GN 1/1 (530 x 325 x 65 mm)	10
Baking standard (600 x 400 x 85 mm)	8
FlexiRack (530 x 570 x 65 mm)	10 (≈ 17x GN 1/1)
Plates (Ø 28 cm on FlexiRack grids)	40
Plates (Ø 32 cm – plate rack trolley)	40
Meals per day	80 - 150 (GN 1/1); 80 - 200 (FlexiRack)

Electricity supply (220 - 240 V)	
Nominal power consumption (kW)	0.6
Voltage (V)	220 - 240 1 (N)PE AC
Fuse protection (A)	1 x 16
Frequency range (Hz)	50 / 60

Electricity supply (120 V)	
Nominal power consumption (kW)	0.6
Voltage (V)	120 1 (N)PE AC
Fuse protection (A)	1 x 16
Frequency range (Hz)	50 / 60

Electricity supply (100 V)	
Nominal power consumption (kW)	0.6
Voltage (V)	100 1 (N)PE AC
Fuse protection (A)	1 x 16
Frequency range (Hz)	50 / 60

Gas connection (GA/GA-E)	
Rated heat load (kW)	18
Type of gas	E & LL; 3B/P
Standard gas pressure – natural gas <sup>3</sup> (mbar)	20; 25
Standard gas pressure – liquid gas <sup>3</sup> (mbar)	30; 37; 50
Consumption rate according to DIN (kg/h)	1.42
Consumption rate according to DIN (m <sup>3</sup> /h)	2.17

Drinking water cold (KW/TWk)	
Water pressure (bar)	2 - 6
Connection size	DN 20 (G ¾" A)
Quality mmol/l (°dH)	< 4 (22.2)
Consumption cleaning (l)	32

Soft water (EW/EWk)	
Water pressure (bar)	2 - 6
Connection size	DN 20 (G ¾" A)
Quality mmol/l (°dH)	< 0.9 (5)
Consumption steaming (l/h)	18
Consumption combisteaming (l/h)	4
Consumption cleaning (l)	3

Waste water (A/A)	
Volume flow max. (l/min.)	10
Connection size	DN 50
Quality	max. 80 °C

Exhaust air (AL)	
Exhaust gas mass flow (kg/h)	49
Exhaust gas discharge system	B13 (with) B23 (without flow safeguard)
Exhaust gas connection	to a ventilation system with safety shutdown
Exhaust gas temperature (°C)	195

According to VDI 2052 with a connection voltage of 400 V.	
Operated without steam condensate hood	
Heat emission latent (W)	2862
Heat emission sensitive (W)	2385
Steam output (g/h)	4214
Operated with FlexiCombi Air condensation hood	
Heat emission latent (W)	859
Heat emission sensitive (W)	2385
Steam output (g/h)	1264
Noise level (db (A))	< 70
Type of protection	IPX5

<sup>3</sup> other types of gas on request

Combi steamer  
**FlexiCombi®**  
 Gas combi steamer FlexiCombi® Classic 10.1  
 MKN-No.: FKG COD115C



world of cooking

FKG COD115C

### Further features

- One hand door handle
- Non-contact door switch, door lock positions with end stop
- Insertable door seal – end user replaceable
- Drip pan with permanent drainage
- Cooking chamber with halogen lighting behind shockproof glass
- Manual cleaning programme (does not apply to WaveClean option)
- Maintenance instructions for external water filters
- **Integrated heat exchanger**
- HACCP basic version
- Integrated HACCP memory
- Timer with start time pre-selection
- Manual steam injection/humidification
- USB interface, e.g. for software updates\*\*
- Loudspeaker, adjustable tone control
- Audible signal after cooking time has elapsed
- Potential free contact for external steam condensate hood
- Direct waste water connection according to DVGW is possible

### Special equipment

216233	Cabinet frame open on all sides (1000 x 655 x 580 mm)
216253	Cabinet closed on three sides (1000 x 696 x 580 mm)
FKG_AIR_6_10	FlexiCombi Air condensation hood
845986	Stacking kit for gas table top appliances (6.x + 10.x / 6.x + 6.x)

### FlexiRack trays (please refer to accessories brochure)

206050	Frying basket
202363	Granite enamelled tray, 20 mm deep
202368	Baking tray – perforated
206045	Grid
10017446	Chicken grill rack
202376	Cup baking tray

### GN 1/1 trays (please refer to accessories brochure)

10012901	Frying basket
202345	Granite enamelled tray, 20 mm deep
202379	Baking tray – perforated
206104	Grid
202375	Cup baking tray

### e.g. Starter, baking, GN packages available!

216257	Plate rack
216259	Roll-in rack for GN 1/1 crosswise insertion
216263	Transport trolley rack, 580 mm high
850256	Roll-in frame for transport trolley rack
201791	Thermal insulation cover

TWO_IN_ONE	WaveClean two-in-one cleaning cartridge
------------	---

813646	GN insert lengthwise
845941	Hanging rack baking tray size
846066	Flow safeguard (exhaust gas duct)

\*\* without surcharge under [www.mkn.com](http://www.mkn.com)

MKN Maschinenfabrik  
 Kurt Neubauer GmbH & Co. KG  
 Halberstaedter Strasse 2a  
 38300 Wolfenbuettel / Germany

Phone +49 (0)5331 89-0  
 Fax +49 (0)5331 89-280  
 E-mail [verkauf@mkn.de](mailto:verkauf@mkn.de)  
[www.mkn.com](http://www.mkn.com)



Please find detailed information at [www.mkn.com/en/login](http://www.mkn.com/en/login)

Subject to technical modifications!  
 Version: 21.10.2020