



THE BEAUTY OF SIMPLICITY

# MODEL: HB FG 3070 TN VSB FLUSH HOB



## PERFORMANCE:

- 72cm Gas Hob
- 3 Burners
  - Front Left: Semi Rapid Burner - 1.75kW
  - Rear Left: Auxiliary Burner - 1.0kW
  - Right: Triple Ring Burner - 3.4kW

## TECHNICAL INFORMATION:

- Product Dimension (WxDxH): 720 x 500 x 120mm
- Cut-Out Dimension (WxD): 703 x 483mm

## PRODUCT FEATURES:

- Cast Iron Pan Supports with Wok Adapter
- Fully Sealed Burner Base
- Battery Ignition
- Flame Failure Safety Devices
- Stainless Steel

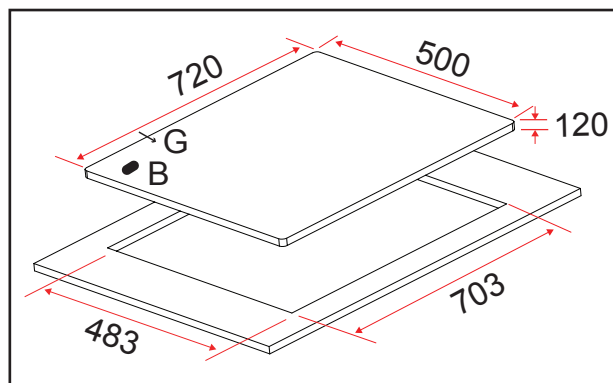

## Note:

G= Gas Inlet / B=Battery Box

Dimension are in "mm"