



THE BEAUTY OF SIMPLICITY

# MODEL: EFH 3760 TN VSB STAINLESS STEEL GAS HOB



## PERFORMANCE:

- 68cm Domino Gas Hob
- 3 Burners:
  - Left: Triple Ring Burner - 3.4kW
  - Front Right: Auxiliary Burner - 1.0kW
  - Rear Right: Rapid Burner - 3.0kW

## TECHNICAL INFORMATION:

- Product Dimension (WxDxH): 680 x 500 x 60mm
- Cut-Out Dimension (WxD): 552 x 470mm

## PRODUCT FEATURES:

- Enamelled Pan Supports with Wok Adapter
- Fully Sealed Burner Base
- Battery Ignition
- Flame Failure Safety Devices
- Stainless Steel

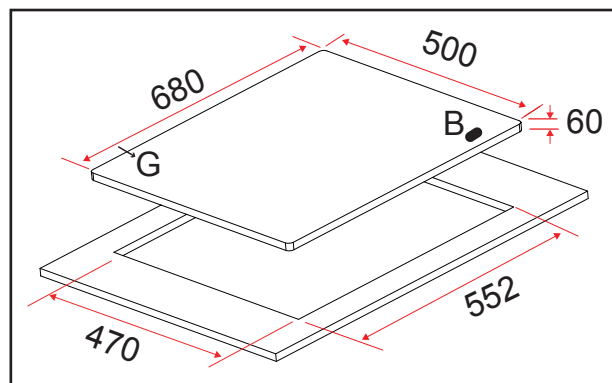

### Note:

G= Gas Inlet / B=Battery Box  
Dimension are in "mm"