

## **KYOWA SERVICE CENTER**

Rm. 1203 State Center Building  
#333 Juan Luna St., Binondo  
Manila, Philippines



## **MICROWAVE OVEN**

**MODEL # KW-3125**

Voltage: 220V a.c.-60Hz Power: 1300 WATTS



**INSTRUCTION MANUAL**

## CONGRATULATIONS

You are now a proud new owner of a KYOWA Microwave Oven model no. KW-3125.

Before using for the first time, kindly take time to carefully read your instruction manual. Please observe all safety precautions and follow operating procedures. After reading, kindly store your instruction manual in a safe place for your future reference. Should you pass on this Microwave Oven to a third party, please hand over this instruction manual as well.

## PARTS DESCRIPTION

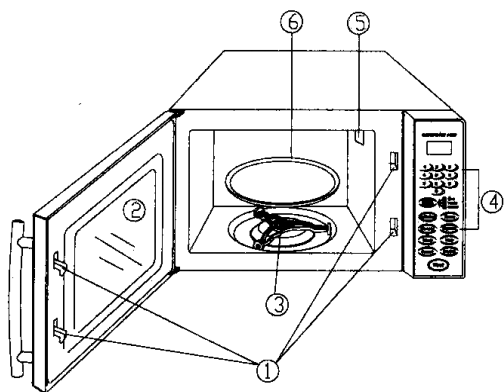

1. Door Safety Lock System
2. Oven Window
3. Turntable Roller
4. Control Panel
5. Wave Guide
6. Glass Tray

## IMPORTANT SAFEGUARDS

When using your Microwave Oven, basic safety precautions should always be followed:

- Always operate your KYOWA Microwave Oven from a power source of the same voltage and frequency rating as indicated on the rating label.
- Place the Microwave Oven on a flat surface and far from the edge of counter top.
- Do not operate your Microwave Oven when empty.
- Do not use or replace accessories of the oven other than the ones originally provided.
- Do not operate the Microwave Oven without the glass tray, roller support, and shaft in their proper position.
- Allow 20cm of space above, 10cm at the back and 5cm at both sides of the oven for proper ventilation.
- Do not operate the Microwave Oven if any part of it has been damaged. Return the appliance to the nearest authorized dealer or service facility for repair.
- Avoid heating foods or liquids in sealed containers inside the Microwave Oven.
- Do not use the Microwave Oven for frying food. Hot oil may damage important parts of the oven.
- Remove shell when cooking eggs inside the Microwave oven to avoid any untoward incidents.
- Use only suitable utensils when placing or removing food inside the oven.
- Never leave the Microwave Oven unattended when in use.
- Avoid touching hot surfaces of the oven during use. Use the handle only.
- Do not operate or place any part of your Microwave Oven on or near any hot surface such as a gas or electric burner, hotplate or heated oven.
- Keep out of reach from children or from persons with mental or physical disabilities when operating the unit.
- Do not leave food, containers and any other utensils inside the oven when not in use.
- To reduce the risk of electric shock, do not immerse or expose oven to rain, moisture or any liquid.
- Switch OFF and unplug the oven from outlet when not in use or before cleaning.
- Hold plug of the oven when unplugging from socket. Do not unplug by pulling the supply cord.
- This KYOWA Microwave Oven is intended for normal domestic/household use only. This model is not suitable for commercial use.

## CONTROL PANEL

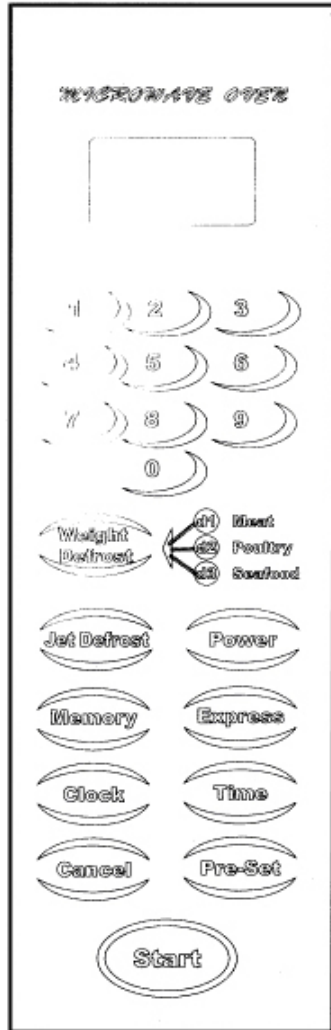

### DISPLAY

Cooking time, power, indicators and present time are displayed.

### NUMBER PADS (0-9)

Touch to set times or weights.

### WEIGHT DEFROST

Use to defrost frozen meat, poultry and seafood by weight. The defrosting time and power level are automatically set once the food category and the weight are programmed.

### JET DEFROST

Touch to set defrosting time; the oven automatically divides the defrosting time into periods of alternating defrost and stand times by cycling on and off.

### POWER

Use to set power level. To check power level during time cooking, touch POWER pad.

### PRE-SET

Use to set the oven to start-up at a later time.

### CLOCK

Use to set the time of day or recall the time of day.

### CANCEL

Touch to clear the selected power level, cook or defrost times that previously programmed. But the time of day clock cannot be cancelled.

### MEMORY

When programming the oven to cook by time, use the MEMORY pad when setting both the 1st and the 2nd cooking stage. The respective lights will come on to indicate which stage the oven is operating in.

### TIME

Use to set cooking time.

### EXPRESS

Use this feature to program the oven for 4 popular microwave timings at HIGH power.

### START

Touch to start the cooking or defrosting programs. The cooking indicator light and the oven light will turn on and the cooling fan will operate.

## PREPARING TO USE THE MICROWAVE OVEN

- Remove all packaging materials from the Microwave Oven. Completely untangle or unwind the power cable of the oven.
- Before initial use, Microwave Oven must be grounded using the provided grounding wire and grounding plug. Oven must be plugged into a wall receptacle that is properly installed and grounded to reduce risk of electric shock by providing an escape wire for the electric current. Consult a qualified service person if you still have questions regarding this.
- When using the Microwave Oven, you may use heat-resistant glasses and ceramics, microwave-safe plastic dishes and containers, and kitchen papers. Never use glasses which are not heat resistant, metal trays, metal racks, aluminum foil and other foil containers inside the oven.
- Use round or oval containers instead of containers with corners. Foods heated inside containers with corners tend to overcook.
- Narrow strips of foil may be used to prevent exposed areas of food to be overcooked, but make sure you don't use too much of aluminum foil. Keep distance of 1 inch between the foil and the cavity.

## MICROWAVE OVEN CONTROLS

### SETTING THE CLOCK

1. Touch CLOCK pad.
2. Touch CANCEL pad.
3. Use the NUMBER pads to enter the correct time. You must touch at least three numbers to set the clock (1 digit for hour and 2 digits for minutes).
4. Touch CLOCK pad again.

### SETTING TIMER

1. Touch TIME pad.
2. Enter the amount of time you want by touching the NUMBER pads. Digit time is in minutes and seconds and set left to right. Set one digit (e.g. 5 for 5 seconds) or up to 4 digits (e.g. 2405 for 24 minutes and 5 seconds).
3. Touch POWER pad.
4. Touch number pad 0.
5. Touch START pad.

\*Touch TIME and then touch CANCEL to cancel time during timing process.

## SETTING COOKING TIMES AND POWER LEVELS

### A. One-stage Cooking

1. Touch TIME pad.
2. Use the Number pads to set a cooking time. You can set a cooking time from 1 second to 99 minutes and 99 seconds. If you are setting a time greater than 1 minute, you must enter numbers for both minutes and seconds. For example, to set 20 minutes, enter 2000.
3. If you want to set a power level other than 100% power, touch POWER, and then use the NUMBER pads to enter the power level. You can set the power level from 1 to 9.
4. Touch START to start cooking.

### POWER LEVELS:

Number Pad	% of Power
9	90%
8	80%
7	70%
6	60%
5	50%
4	40%
3	30%
2	20%
1	10%

### B. Two-stage Cooking

1. SET STAGE 1:  
Follow steps 1 and 2 in One-stage Cooking but do not touch START pad.
2. SET STAGE 2:  
Touch MEMORY pad then enter proper cooking time and power level (Most 2-stage recipes use lower power for second stage).
3. Touch START pad.

\*The respective lights will illuminate to indicate which stage the oven is operating in. After total time has elapsed, the oven will sound 3 beeps. After cooking or defrosting program has completed, the oven will automatically continue to sound three beeps every two minutes until the door is opened or the CANCEL pad is touched.

## PRE-SET

Suppose you want to set the oven to start-up at 2 o'clock.

1. Touch PRE-SET pad.
2. Touch NUMERAL pads 2-0-0.
3. Set the cooking programs.
4. Touch START pad.

## EXPRESS

The oven will operate at HIGH power (100% power output) for EXPRESS cooking program. Suppose you want to set the oven to cook for 1 minute at 100% power by using the feature:

1. Touch the EXPRESS pad 3 times then 1.00 will appear in the display.
2. Touch START pad.

\*With each touch of the EXPRESS pad, you can program the oven for:

- 15 seconds – touch once
- 30 seconds – touch twice
- 1 minute – touch 3 times
- 2 minutes – touch 4 times

## SETTING JET DEFROST

1. Touch JET DEFROST pad.
2. Enter desired defrosting time by touching number pads. Digital timer sets minutes and seconds from left to right so a single digit can be set (5 for 5 seconds) or up to 4 digits (2405 for 24 minutes and 5 seconds).
3. Touch START pad.

## SETTING WEIGHT DEFROST

Suppose you want to defrost 600 grams shrimp.

1. Touch WEIGHT DEFROST pad 3 times. "d3" will appear in the display.
2. Touch number pads 600.
3. Touch START pad.

\*The maximum allowable weight for each category is shown below:

FOOD CATEGORY	MAXIMUM WEIGHT	DISPLAY
Meat	2300g	d1
Poultry	4000g	d2
Seafood	900g	d3

\*For food exceeding maximum weight, use the JET DEFROST program. If you program weight in excess of the maximum recommended, the oven will not operate properly.

#### **PROGRAM COOKING**

The oven has the ability to be programmed to do several consecutive functions.

Suppose you want set the following program:

- JET DEFROST.

- 1<sup>st</sup> stage: cook for 5 minutes at 100%.

- 2<sup>nd</sup> stage: cook for 10 minutes at 50%.

1. Touch CANCEL pad.
2. Input JET DEFROST program.
3. Touch MEMORY pad.
4. Input time (5 minute) and power level (100%) cooking program.
5. Touch MEMORY pad.
6. Input time (10 minutes) and power level at (50%) cooking program.
7. Touch START pad.

\*JET DEFROST and WEIGHT DEFROST can only be selected before the cooking stage in a program. It cannot be selected between or after stage 1 or stage 2.

#### **SETTING SAFETY LOCK**

Use to prevent unsupervised operation of the oven by little children. The CHILD LOCK indicator will show up on display screen, and the oven cannot be operated while the CHILD LOCK is set.

1. To set the CHILD LOCK: Press and hold the CANCEL button for 3 seconds. The lock indicator will illuminate and the oven will sound a beep indicating that the oven is locked.
2. To cancel the CHILD LOCK: Press and hold the CANCEL button for 3 seconds until the lock indicator on display goes off.

## **CLEAN AND CARE**

- Wipe internal and external parts of the Microwave Oven using a soft, damp cloth and a mild detergent.
- Avoid water or any other liquids to seep into the Control Panel.
- Glass Tray and Roller Ring of the oven may be washed in warm, soapy water.
- Wipe dry the unit with a soft and dry cloth.
- Do not use harsh cleaning agents or abrasive objects (e.g. scrubbing pads or metal brushes) for cleaning.
- Replace parts in the oven before operating again.
- To remove residual odour from your oven, combine a cup of water with lemon juice and skin in a microwavable bowl. Microwave for 5 minutes. Allow oven to cool down then wipe thoroughly with a dry cloth.
- Put back parts and accessories of the Microwave Oven to their proper places before operating again.
- Store oven in a cool and dry place.

## **SERVICE**

- If your Microwave Oven malfunctions or appears damaged in any manner, please bring the complete product unit to your place of purchase or to any authorized KYOWA dealers for inspection, repair or replacement.
- **CAUTION:** To reduce the risk of electric shock, do not disassemble your KYOWA Microwave Oven by yourself. No user serviceable parts inside. Refer all needed repair to an authorized KYOWA service facility ONLY.