

KYOWA SERVICE CENTER (MAIN)

RM. 1203, STATE CENTER BLDG, #333 JUAN LUNA ST, BINONDO MANILA
TEL: 242-1731 - 35

METRO MANILA

TRONIX QUEZON CITY (MAIN) #777 N.S. AMORANTO ST, COR. STO. DOMINGO AVE, Q.C.
TEL: 743-9094 / 749-8477 MOBILE: 0922-8534797/0917-5231489 CONTACT PERSON: MS. JENIELYN MANZANO

TRONIX MANILA #1793 CONCEPCION AGUILA ST, NEAR J.P. LAUREL ST, SAN MIGUEL, MANILA (NEAR MALACANANG)
TEL: 743-4088 MOBILE: 0922-7909555 CONTACT PERSON: MS. ANALEN FIADACAN

TRONIX STA. CRUZ #910 LUZON ST. (BET. MASANGKAY & BENAVIDEZ ST.) STA. CRUZ, MANILA
TEL: 542-8345 / 310-3553 MOBILE: 0922-2389971 CONTACT PERSON: MS. SHEILA PIRANTE

TRONIX SAN JUAN #135 N.DOMINGO ST, CORNER PINAGLABANAN, BRGY. BALONG BATO, SAN JUAN CITY
TEL: 949-3608 / 984-6395 MOBILE: 0922-9218653 CONTACT PERSON: MS. MICHELLE CASAÑA

TRONIX ALABANG TOWN CENTER LA-7 SERVICE TOWN, ALABANG TOWN CENTER, MUNTINLUPA CITY
TEL: 807-3546 / 624-6880 MOBILE: 0922-7584917 / 0917-5899059 CONTACT PERSON: MR. FRANCIS ACOSTA

TRONIX PARAÑAQUE #103 CMSR BLDG, PHASE 1, 88 PRESIDENT AVENUE, BF HOME, PARAÑAQUE
TEL: 622-4540 / 861-0092 / 828-2915 MOBILE: 0917-5978342 / 0932-4060806 CONTACT PERSON: MS. ELIZABETH PALIMA

TRONIX MAKATI #103 MJM BLDG, 650 JP RIZAL ST, BRGY. VALENZUELA MAKATI CITY
TEL: 710-1980 / 949-3684 MOBILE: 0932-1999085

TRONIX MARIKINA #572 J.P. RIZAL AVE, CONCEPCION 1, MARIKINA (IN FRONT OF KSERVICO)
TEL: 696-6411 MOBILE: 0942-0940088

TRONIX PASIG LOWER GROUND SERVICE LANE, SM CENTER, PASIG
TEL: 703-5599 / 234-9020 MOBILE: 0932-1999372 CONTACT PERSON: MS. NORA CRESENCIO

TRONIX SHAW - MANDALUYONG #412 SHAW BLVD, COR. TORRES & CALDERON ST, MANDALUYONG CITY
TEL: 542-8360 / 725-7290 MOBILE: 0923-1646350 CONTACT PERSON: MS. SHERLY DELA CRUZ

TRONIX COMMONWEALTH LAGMANLAG COMMONWEALTH AVE, HOLY SPIRIT, DILIMAN, Q.C. (BESIDE SHELL)
TEL: 623-7266 MOBILE: 0933-6584465 / 09175810546 CONTACT PERSON: MR. MANNY SAGAYAP

CAVITE

TRONIX CAVITE KM 16, AGUINALDO HI-WAY, NIOG 1-A, PANAPAAN 1, BACOR, CAVITE
TEL: (046) 519-0755 / (046) 475-6362 MOBILE: 0932-1991811 CONTACT PERSON: MS. MEANN DIONISIO

CEBU

MARKWELL ENTERPRISES #85 SIKATUNA ST, CEBU CITY
TEL: (032) 253-0752 MOBILE: 0917-6256934 CONTACT PERSON: MR. BOY SOUICO

BIO PLUS ELEC. REPAIR CENTER C. PADILLA ST, SAN ROQUE, MAMBALING, CEBU CITY
TEL: (032) 262-1339 MOBILE: 0922-4744991 CONTACT PERSON: MS. ZYSELDA MABUTE

DAVAO

KOOL EXPRESS DOOR 5, LUA BLDG, QUIRINO AVE, DAVAO CITY
TEL: (082) 227-6369 MOBILE: 0908-420-6303 CONTACT PERSON: MS. DORIS ASIRIT

ILOILO

NACES APPLIANCE CORPORATION NACES BLDG, #10 DELGADO ST, ILOILO
TEL: (033) 337-7696 MOBILE: (033) 508-2205 CONTACT PERSON: MS. LORELIE LIM

TARLAC

TARLAC MAC ENTERPRISES INC. BLK. 9, MCARTHUR HIGHWAY, SAN NICOLAS, TARLAC
TEL: (045) 982-3178 MOBILE: 0922-8597136



HOT & COLD WATER DISPENSER

MODEL # KW-1514

Voltage: 230V a.c. 60Hz Power: 500 W (Hot) 85 W (Cold)



INSTRUCTION MANUAL

CONGRATULATIONS

You are now a proud new owner of a KYOWA Water Dispenser model no. KW-1514.

Before using for the first time, kindly take time to carefully read your instruction manual. Please observe all safety precautions and follow operating procedures. After reading, kindly store your instruction manual in a safe place for your future reference. Should you pass on this Water Dispenser to a third party, please hand over this instruction manual as well.

PARTS DESCRIPTION

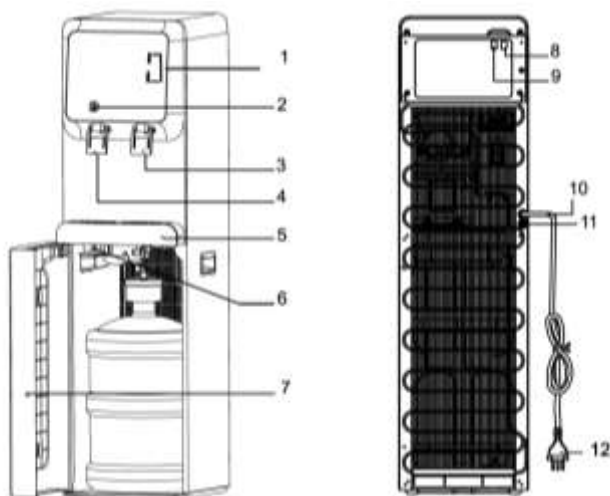

| NO. | NAME | NO. | NAME |
|-----|-------------------|-----|----------------|
| 1 | INDICATOR LIGHTS | 7 | BOTTOM DOOR |
| 2 | SAFETY LOCK | 8 | HEATING SWITCH |
| 3 | COOL WATER FAUCET | 9 | COOLING SWITCH |
| 4 | HOT WATER FAUCET | 10 | POWER CORD |
| 5 | WATER COLLECTOR | 11 | DRAIN CAP |
| 6 | RESET BUTTON | 12 | PLUG |

IMPORTANT SAFEGUARDS

When using the Water Dispenser, basic safety precautions should always be followed:

- Always operate your KYOWA Water Dispenser from a power source of the same voltage and frequency rating as indicated on the rating label.
- Grounding wire must be installed in grounding terminal at home to reduce the risk of electric shock.
- Connect the Water Dispenser unit only to properly wired wall outlets.
- **Always keep the Water Dispenser upright – never tilt or turn the unit upside-down. In case the unit was tilted during transportation, put up the Water Dispenser for 48 hours before plugging into the power supply.**
- Do not use Water Dispenser in damp or wet area. Keep dry the motor and the base of the unit.
- Do not operate or place any part of your KYOWA Water Dispenser on or near any hot surface such as a gas or electric burner, hotplate or heated oven.
- Place the Water Dispenser on a flat area surface. Never turn the unit upside down.
- Keep at least 20 cm. of space between the wall and the Water Dispenser, and 10 cm on both sides of the unit.
- Always check that the drain plug is fastened tightly into the Water Dispenser.
- This unit is most suitable for 5-gallon water bottles.
- **Do not plug in Water Dispenser or set the Heating switch to ON until the water runs out from the hot water tap.**
- Do not operate the Water Dispenser if any part of it has been damaged. Return the appliance to the nearest authorized dealer or service facility for repair.
- Do not use or replace accessories other than the ones originally provided.
- Hold plug when unplugging from socket. Do not unplug by pulling the supply cord.
- To reduce the risk of electric shock, do not immerse or expose the Water Dispenser to rain, moisture or any liquid.
- If this unit is not intended to be used for a long time, turn power switch of Water Dispenser to OFF, unplug socket from the power supply and drain out remaining water from the Water Dispenser unit.

- Keep out of reach from children or from persons with mental or physical disabilities.
- This KYOWA Water Dispenser is intended for normal domestic/household use only. This unit is not suitable for commercial use.

WATER DISPENSER WALL INSTALLATION

1. Before turning the machine on, the machine must be fixed in place, either to the wall, or some other stable object.
2. Drill a hole (60 x 30mm) on the wall or other stable object. Insert the small pipe and screw (4 x 36mm) into the hole. Turn the screw until it is firmly set in place. Fit the unit to the screw making sure the unit is in a straight horizontal position.

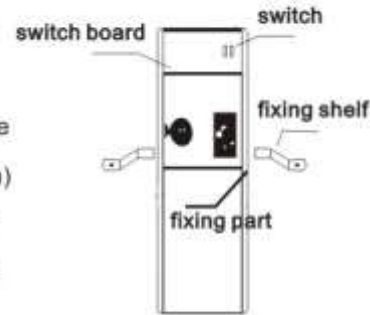

HOW TO USE

WATER BOTTLE INSTALLATION

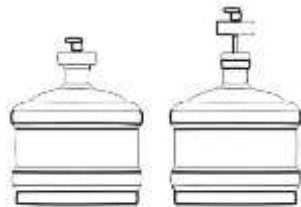
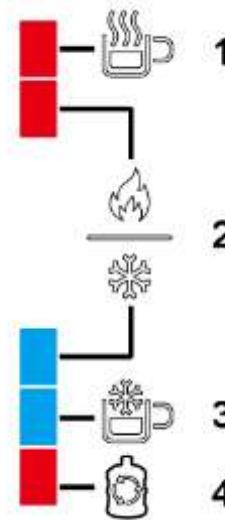

FIGURE 1

- Remove plastic lid over the mouth of the water bottle.
- Insert hose into the water bottle then firmly press bottle cap into the lid. (FIGURE 1)
- **Reminder: The unit has a door sensor for safety purposes. It will not function if the lower cabinet door is open.**

WATER DISPENSER INDICATOR LIGHT PANEL



- **1. HOT WATER INDICATOR** (red light) – illuminates to indicate that hot water was able to reach set temperature; hot water is available
- **2. HEATING** (red light) / **COOLING** (blue light) – turns ON to indicate that Water Dispenser is currently heating up/cooling down water
- **3. COLD WATER INDICATOR** (blue light) – illuminates to indicate that hot water was able to reach set temperature; cold water is available
- **4. REFILL** (red light) – this light illuminates to indicate that sensor detects low water level in the bottle. Replace or refill water bottle then close Water Dispenser cabinet door to reset unit; REFILL indicator light will then turn OFF.

WATER DISPENSING FUNCTION

- Install water bottle into the Water Dispenser following the WATER BOTTLE INSTALLATION instruction.
- Close water dispenser cabinet door, then plug unit into a wall receptacle that is properly installed and grounded to reduce risk of electric shock. Make sure the heating switch is turned OFF.
- When using Water Dispenser for the first time, allow at least 1 gallon of water to come out of the HOT and COLD Water Dispenser faucets to wash out all factory oil or dirt residues.
- Turn ON heating and/or cooling function by pressing HOT and/or COLD buttons at the back part of the Water Dispenser. Allow Water Dispenser to heat up or cool down water for a couple of minutes, press cup into the cool water faucet to dispense cold water; to dispense hot water, press safety lock then press cup into the hot water faucet simultaneously.
- For initial use, wait for about 30 minutes before dispensing hot and cold water from the Water Dispenser.

TROUBLE SHOOTING

| PROBLEM | POSSIBLE CAUSE | SOLUTION |
|--|---|--|
| Water coming out from the hot and cold dispenser is lukewarm | <ol style="list-style-type: none"> 1. Water from the hot and cold container has already been consumed 2. No power supply | <ol style="list-style-type: none"> 1. Wait for about three minutes to allow cooling or heating of water from the unit 2. Check if the power cord is properly plugged into the power supply |
| No water coming out from the dispenser | <ol style="list-style-type: none"> 1. The water bottle is empty 2. Hose cap and Water Dispenser connector is not properly attached | <ol style="list-style-type: none"> 1. Replace with another bottle of water. 2. Make sure that the bottle hose cap and water dispenser has been properly attached together |
| Too much noise when dispensing water from the unit | <ol style="list-style-type: none"> 1. Water Dispenser is tilted or not installed properly | <ol style="list-style-type: none"> 1. Place unit upon a flat area and stable surface |
| Water leaks from the faucet | <ol style="list-style-type: none"> 1. Faucet assembly into the unit is loose 2. Faucet has been damaged | <ol style="list-style-type: none"> 1. Tighten threaded portion of the faucet by turning it clockwise 2. Contact Kyowa Service Center for repair |
| Water leaks out from the Water Dispenser | <ol style="list-style-type: none"> 1. Hose connector is not connected properly. 2. Water is leaking out from the water tank 3. The drain cap on the back of the dispenser is not properly closed | <ol style="list-style-type: none"> 1. Make sure to connect hose properly 2. Contact Kyowa Service Center for repair 3. Tighten drain cap |

CLEAN AND CARE

- Remove drain cap at the back of the water dispenser unit to drain water from the hot and cold water dispenser tank.
- Wash movable parts of the Water Dispenser including the bottle cap, hose, and drip tray, using mild detergent and water.
- Wipe body of the Water Dispenser using a soft and damp cloth.
- Pat dry parts of the Water Dispenser using a soft and dry cloth.
- Put back parts and accessories of the Water Dispenser to their proper places before operating again.
- Do not allow any kind of liquid to seep into the electrical system of the unit.
- Do not use harsh cleaning agents or abrasive objects (e.g. scrubbing pads or metal brushes) for cleaning.

SERVICE

- Do not operate your KYOWA Water Dispenser if the unit malfunctions or appears damaged in any manner. Bring the complete product to the place of purchase or to any authorized KYOWA dealers for inspection, repair or replacement.
- Do not disassemble your KYOWA Water Dispenser by yourself. No user serviceable parts inside. Refer all needed repair to an authorized KYOWA service facility ONLY.