

KYOWA SERVICE CENTER (MAIN)

RM. 1203, STATE CENTER BLDG, #333 JUAN LUNA ST, BINONDO MANILA
TEL: 242-1731 - 35

METRO MANILA

TRONIX QUEZON CITY (MAIN) #777 N.S. AMORANTO ST, COR. STO. DOMINGO AVE, Q.C.
TEL: 743-9094 / 749-8477 MOBILE: 0922-8534797/0917-5231489 CONTACT PERSON: MS. JENIELYN MANZANO

TRONIX MANILA #1793 CONCEPCION AGUILA ST, NEAR J.P. LAUREL ST, SAN MIGUEL, MANILA (NEAR MALACANANG)
TEL: 743-4088 MOBILE: 0922-7909555 CONTACT PERSON: MS. ANALEN FIADACAN

TRONIX STA. CRUZ #910 LUZON ST. (BET. MASANGKAY & BENAVIDEZ ST.) STA. CRUZ, MANILA
TEL: 542-8345 / 310-3553 MOBILE: 0922-2389971 CONTACT PERSON: MS. SHEILA PIRANTE

TRONIX SAN JUAN #135 N.DOMINGO ST, CORNER PINAGLABANAN, BRGY. BALONG BATO, SAN JUAN CITY
TEL: 949-3608 / 984-6395 MOBILE: 0922-9218653 CONTACT PERSON: MS. MICHELLE CASAÑA

TRONIX ALABANG TOWN CENTER LA-7 SERVICE TOWN, ALABANG TOWN CENTER, MUNTINLUPA CITY
TEL: 807-3546 / 624-6880 MOBILE: 0922-7584917 / 0917-5899059 CONTACT PERSON: MR. FRANCIS ACOSTA

TRONIX PARAÑAQUE #103 CMSR BLDG, PHASE 1, 88 PRESIDENT AVENUE, BF HOME, PARAÑAQUE
TEL: 622-4540 / 861-0092 / 828-2915 MOBILE: 0917-5978342 / 0932-4060806 CONTACT PERSON: MS. ELIZABETH PALIMA

TRONIX MAKATI #103 MJM BLDG, 650 JP RIZAL ST, BRGY. VALENZUELA MAKATI CITY
TEL: 710-1980 / 949-3684 MOBILE: 0932-1999085

TRONIX MARIKINA #572 J.P. RIZAL AVE, CONCEPCION 1, MARIKINA (IN FRONT OF KSERVICO)
TEL: 696-6411 MOBILE: 0942-0940088

TRONIX PASIG LOWER GROUND SERVICE LANE, SM CENTER, PASIG
TEL: 703-5599 / 234-9020 MOBILE: 0932-1999372 CONTACT PERSON: MS. NORA CRESENCIO

TRONIX SHAW - MANDALUYONG #412 SHAW BLVD, COR. TORRES & CALDERON ST, MANDALUYONG CITY
TEL: 542-8360 / 725-7290 MOBILE: 0923-1646350 CONTACT PERSON: MS. SHERLY DELA CRUZ

TRONIX COMMONWEALTH LAGMANLAG COMMONWEALTH AVE, HOLY SPIRIT, DILIMAN, Q.C. (BESIDE SHELL)
TEL: 623-7266 MOBILE: 0933-6584465 / 09175810546 CONTACT PERSON: MR. MANNY SAGAYAP

CAVITE

TRONIX CAVITE KM 16, AGUINALDO HI-WAY, NIOG 1-A, PANAPAAN 1, BACOR, CAVITE
TEL: (046) 519-0755 / (046) 475-6362 MOBILE: 0932-1991811 CONTACT PERSON: MS. MEANN DIONISIO

CEBU

MARKWELL ENTERPRISES #85 SIKATUNA ST, CEBU CITY
TEL: (032) 253-0752 MOBILE: 0917-6256934 CONTACT PERSON: MR. BOY SOUICO

BIO PLUS ELEC. REPAIR CENTER C. PADILLA ST, SAN ROQUE, MAMBALING, CEBU CITY
TEL: (032) 262-1339 MOBILE: 0922-4744991 CONTACT PERSON: MS. ZYSELDA MABUTE

DAVAO

KOOL EXPRESS DOOR 5, LUA BLDG, QUIRINO AVE, DAVAO CITY
TEL: (082) 227-6369 MOBILE: 0908-420-6303 CONTACT PERSON: MS. DORIS ASIRIT

ILOILO

NACES APPLIANCE CORPORATION NACES BLDG, #10 DELGADO ST, ILOILO
TEL: (033) 337-7696 MOBILE: (033) 508-2205 CONTACT PERSON: MS. LORELIE LIM

TARLAC

TARLAC MAC ENTERPRISES INC. BLK. 9, MCARTHUR HIGHWAY, SAN NICOLAS, TARLAC
TEL: (045) 982-3178 MOBILE: 0922-8597136



ELECTRIC WATER POT

MODEL NO.: KW-1320

Voltage: 220V a.c. 60Hz Power: 500 WATTS



INSTRUCTION MANUAL

CONGRATULATIONS

You are now a proud new owner of a KYOWA Electric Water Pot model no. KW-1320.

Before using for the first time, kindly take time to carefully read your instruction manual. Please observe all safety precautions and follow operating procedures. After reading, kindly store your instruction manual in a safe place for your future reference. If you pass this Electric Water Pot to a third party, this instruction manual must also be handed over.

PARTS DESCRIPTION

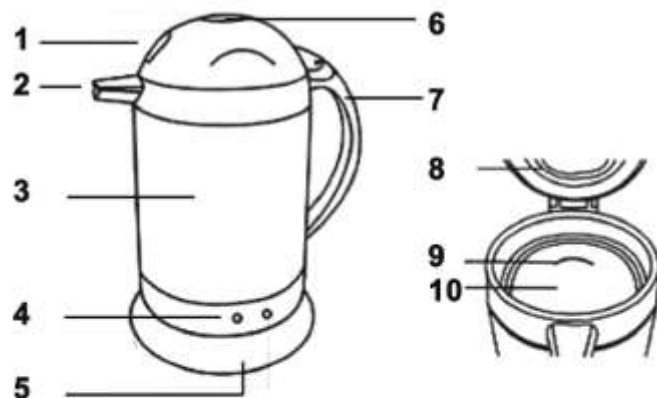

1. LID LOCK
2. SPOUT
3. BODY
4. POWER ON/ KEEP WARM
INDICATOR LIGHTS
5. BASE

6. OPEN/CLOSE SPOUT
7. HANDLE
8. RUBBER SEAL
9. MAX MARK
10. POT

IMPORTANT SAFEGUARDS

When using the Electric Kettle, basic safety precautions should always be followed:

- Always operate your KYOWA Electric Water Pot from a power source of the same voltage and frequency rating as indicated on the rating label.
- Make sure that the kettle is unplugged when filling with (cold) water.
- Always ensure that the kettle cover is in place when boiling water.
- Connect the Electric Water Pot unit only to properly wired wall outlets.
- Do not use Electric Water Pot in damp or wet area. Keep dry the exterior and the base of the kettle.
- Do not place the Electric Water Pot on uneven surfaces. Place upon a flat area surface.
- Do not operate or place any part of your KYOWA Electric Water Pot on or near any hot surface such as a gas or electric burner, hotplate or heated oven.
- Do not operate the Electric Water Pot if any part of it including the supply cord has been damaged. Return the appliance to the nearest authorized dealer or service facility for repair.
- Do not use the unit other than its intended function to avoid any untoward incident.
- Do not use or replace parts including the stand, and accessories other than the ones originally provided.
- Never leave the Electric Water Pot unattended when in use.
- Do not move Electric Water Pot when power is ON or when the water inside is still boiling. Turn power to OFF before moving.
- Avoid touching hot surfaces of the Electric Water Pot during use. Use the cover or handle only.
- Electric Water Pot body and heater may be hot even after use; use caution when handling the unit.
- Turn OFF the Electric Water Pot before removing from the base.
- Hold plug when unplugging from socket. Do not unplug by pulling the supply cord.
- Switch OFF and unplug the Electric Water Pot from outlet before filling, emptying, when not in use or before cleaning.
- To reduce the risk of electric shock, do not immerse or expose the Electric Water Pot to rain, moisture or any liquid; avoid spillage on the power cord, base, or any connectors of the unit.

- This appliance is not intended for use by persons (including children) with reduced physical, sensory or mental capabilities, lack of experience and knowledge, unless they have been given supervision or instruction concerning use of the appliance by a person responsible for their safety.
- Children should be supervised to ensure that they do not play with the appliance.
- This KYOWA Electric Kettle is intended for normal domestic/household use only. This unit is not suitable for commercial use.

HOW TO USE

1. Open the pot's lid by pushing the lid lock. Wash the pot with lukewarm water before using for the first time.
2. Fill pot with cold water reaching the MIN mark but not exceeding the MAX marking to prevent overflowing when boiling. (Fig. 1)
3. Put back the pot's lid and press down to lock. (Fig. 2)



4. Upon reaching the boiling point, Boil Indicator Lamp will automatically switch OFF and Keep Warm Lamp will light ON. Discard water when boiling for the first time.
5. Unplug power cord first before pouring out water. Press down Open/Close Spout button located on the cover. (See Fig. 4)



CLEAN AND CARE

- After every use, wipe Electric Water Pot unit with a soft and damp cloth.
- Never use abrasive cleaning agents or any metallic and sharp objects (e.g. scrubbing brush or knife) for cleaning.
- Do not use dishwasher to clean any part of the Electric Water Pot.
- Wipe dry all parts using a soft and dry cloth.
- Store in a cool and dry place.
- Remove lime scaling when you observe an excess of steam or if boiling time takes too long. If the water in your area is alkaline rich, it is highly recommended to remove lime scaling every two months. To do so:
 1. Dilute 50ml vinegar in 1 liter of water and fill the pot with the mixture. Bring to a boil then switch pot to OFF. Allow mixture to stand overnight.
 2. Bring the mixture to boil again then discard mixture. Clean the pot with warm soapy water. To eliminate vinegar residues, operate the Electric Water Pot with water for two cycles.

SERVICE

- Do not operate your KYOWA Electric Water Pot if the unit malfunctions or appears damaged in any manner. Bring the complete product to the place of purchase or to any authorized KYOWA dealers for inspection, repair or replacement.
- Do not disassemble the Electric Water Pot by yourself. No user serviceable parts inside. Refer all service to an authorized KYOWA service facility ONLY.