



# USER INSTRUCTIONS

## FRONT/REAR LIFT STRUT SPACERS

for

**2018 – 2022 Ford Ranger Raptor**

**2018 – 2022 Ford Ranger**

**2022 – Current Next Gen Ranger Raptor**

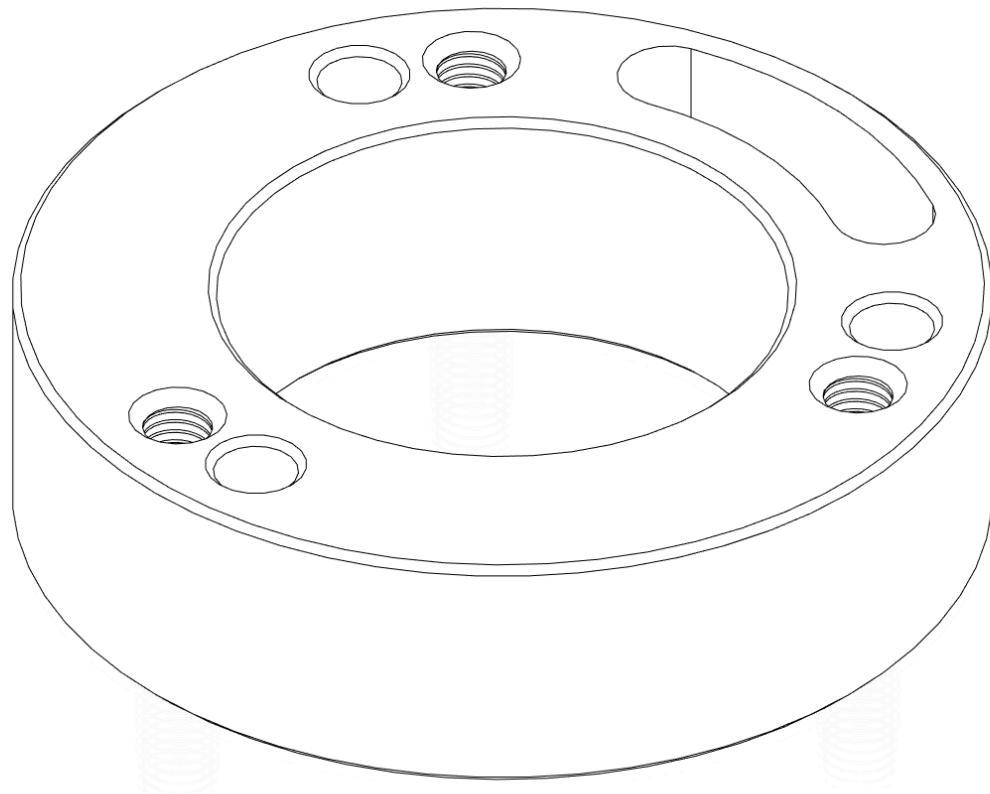

## WHATS IN THE BOX

- 2x billet alloy spacers
- 6x M10 x 60mm (2in) or 45mm (1in) button head bolts
- 6x M10 Flange nyloc nuts

### NOTES:

- Professional installation is HIGHLY recommended. G.O.A.T Offroad accepts no liability arising from installation by unqualified persons.
- Spring need to be removed from strut to install these spacers
- You must get a wheel alignment after installing this kit.

### Step 1

Jack front of vehicle and rest on jack stands. Remove front wheels from vehicle.

### Step 2

Remove strut from the vehicle

### Step 3

Using a spring compressor, remove spring from strut.

### Step 4

Using a press or a hammer, remove M10 studs from strut top cap

### Step 5

Bolt strut spacer to top cap through factory stud holes, using supplied M10x60mm bolts.

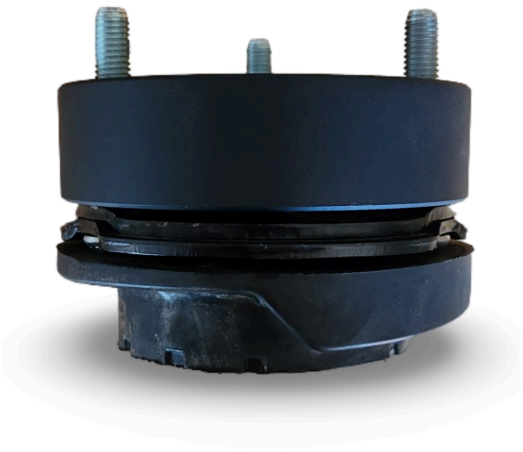

## Step 6

Reassemble strut and install in vehicle. Repeat on other side.

We hope you enjoy the benefits of this great Australian-designed and made product!

### Need help?

If you have any issues, questions or get stuck with the install, please email us at [info@goatoffroad.com.au](mailto:info@goatoffroad.com.au)