

STADESK

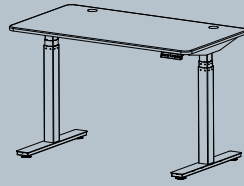

ASSEMBLY INSTRUCTIONS

Included in the boxes:

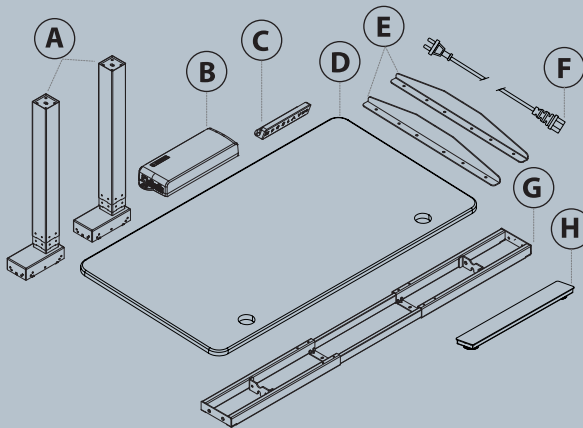

A. Leg	x2
B. Control Box	x1
C. Key pad	x1
D. Desk Top	x1
E. Bracket	x2
F. Power Cable	x1
G. Support Beam	x1
H. Foot	x2

Screws included
(actual size):

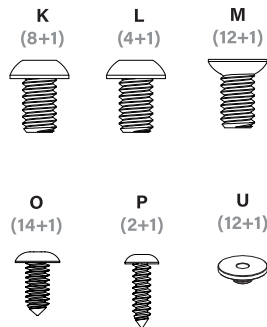

Tools needed:

4mm Allen wrench
(included)

Screwdriver
(not included)

INSTRUCTIONS FOR ASSEMBLY

1. Loosen 4 (L) of Support Beam (G) using 4mm Allen wrench, adjust Beam to proper position to fit the Desk Top (D), and then retighten the screws to lock.

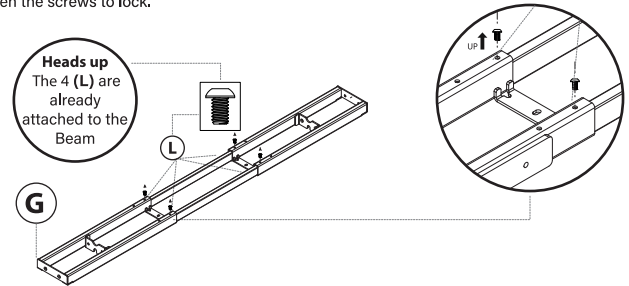

2. Attach Legs (A) to the Support Beams (G) using 8 (M).

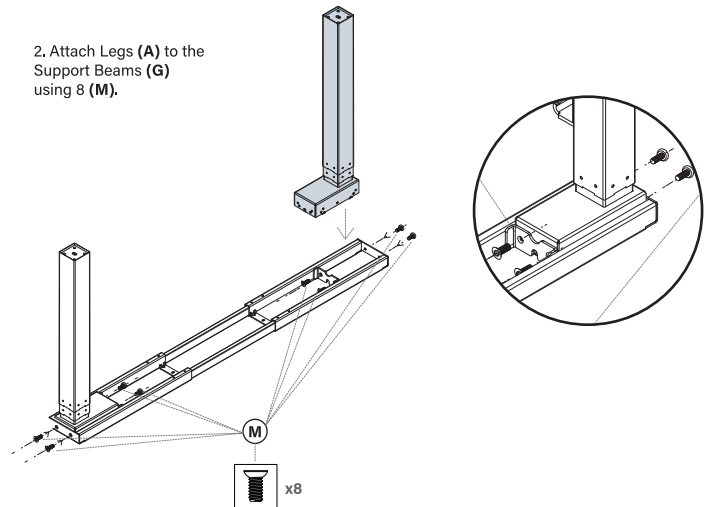

3. Attach Feet (H) to the Legs (A) using 8 (K).

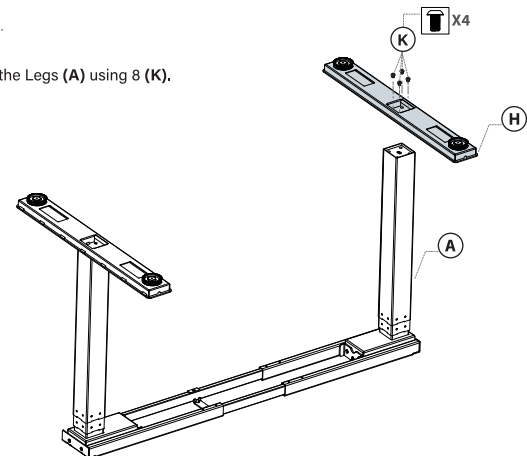

4. Flip the frame up and attach Brackets (E) to the ends of the Support Beam using 4 (M).

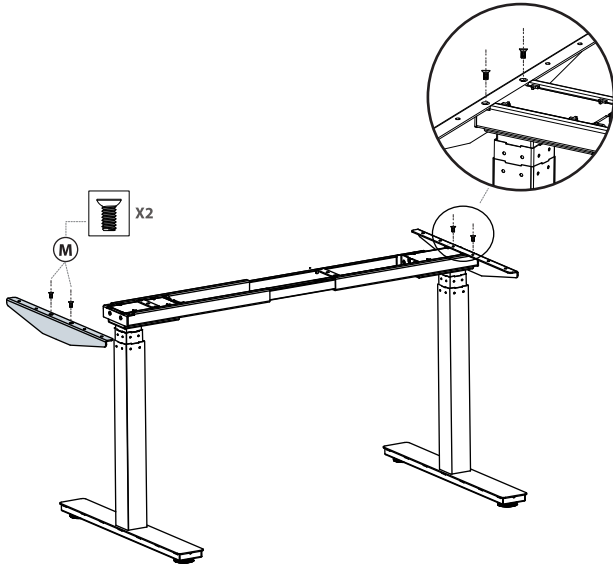

5. Attach 12 Rubber Cushions (U) to the top of the Brackets and Beam.

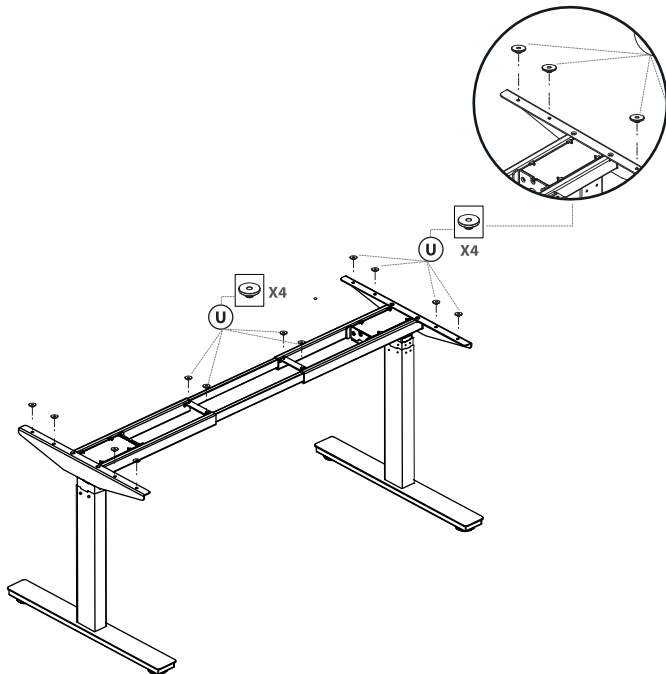

6. With a partner, lay the Desk Top (D) upside down on the ground and attach the Beam using 12 (O).

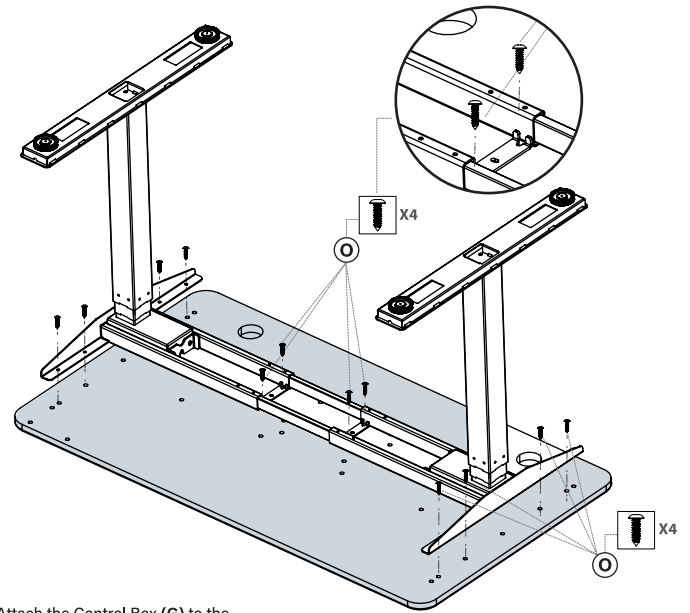

7. Attach the Control Box (G) to the bottom of the table using 2 (O).

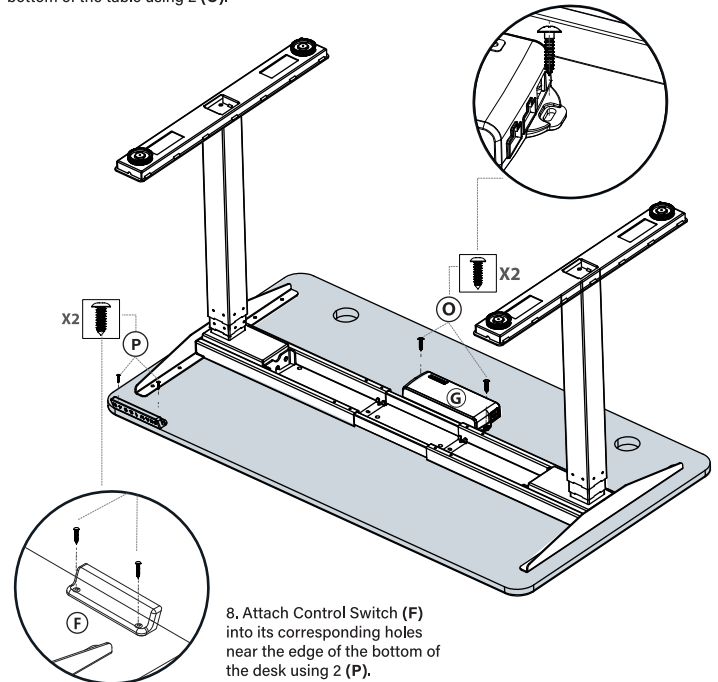

8. Attach Control Switch (F) into its corresponding holes near the edge of the bottom of the desk using 2 (P).

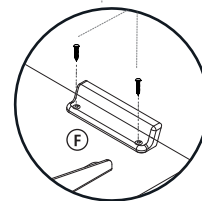

9. Connect the Control Box (B) to corresponding Control Switch (C), and Legs cable (N). Repeat process with the Desk on other side.

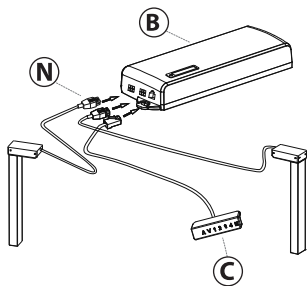

10. Plug the Power Cable (F) into Control Box (B) and then into a power outlet. Repeat process with the Desk on other side.

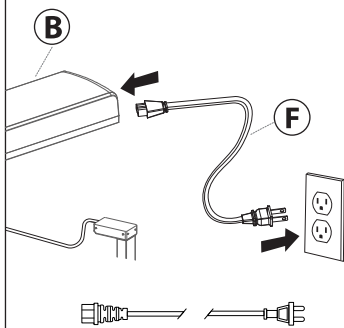

NOTE: Make sure no obstacles are in the desk's path. Make sure cords are a length that will accommodate the change in height.

11. Before use, reset each Control Box following these instructions on both sides.

IMPORTANT! You must RESET the desk prior to use.



Press up and down buttons at the same time until it beeps and goes down to the lowest level

Release both buttons and press down button until exact height appears on display.



INSTRUCTIONS FOR USE

1. Adjust SmartDesk's height

Press "Up" or "Down" button to adjust the height of the desk.

2. Program pre-set buttons

To use the presets on the SmartDesk, please follow the steps:

Set the desk to the height you like.

Press the M button until the LED flashes.

Press the number you want the desk set to.

3. Reset the desk

Unplug the power cord to the control box.

Unplug the cable from the keypad to the control box.

Plug all the cables again.

Do the reset: Press up and down buttons at the same time until it beeps and goes down to the

Lowest level: Release both buttons, then press only down until it shows the exact height.

Your desk is ready to use.

Before use make sure that:

The legs are level and start at the lowest position.

All the screws are tightened or else the desk will make noise/ wobble.

DESK PLACEMENT

When moving the desk, DO NOT lift the desk by the desktop alone. Support both the frame and the desk top equally. Favoring one over the other can stress the fasteners connecting the desk frame to the desktop. Lower the desk completely before moving it.

Choose a placement for the desk that's a safe distance from window frames, radiators, furniture, etc., so that people do not get stuck or trapped by the desk, and nothing obstructs the desk from rising or lowering.

Ensure adequate cord clearance before using the desk. Connect desk's power cord to the 110V - 240V outlet to make the desk ready for use.

Do not place any objects underneath the desk that are taller than 25".