

Mobile shelf Line Up

Line Up is the ideal solution for storing all necessary work tools and accessories, magazines Width books that may be necessary as a small reference library for development processes Width that greatly simplify teamwork, as the archive and a material magazine can travel from room to room, as it were. Line Up's storage solution is an ideal solution for ideation and design thinking processes due to its narrow and light structure.

Details

Dimensions H x W x D	180 x 150 x 57 cm
Total depth shelves	32 cm
Weight	51 kg
Max. Load capacity	80 kg

Materials

Structure	Solid wood (Oak or Ash)
Frame and shelves	powder coated sheet steel (RAL 9005)

Shipping details

Volume shipping weight	58 kg
Packages	5
Shipping method	Freight forwarding

Options

Castor colors	<input checked="" type="radio"/> <input type="radio"/>
---------------	--

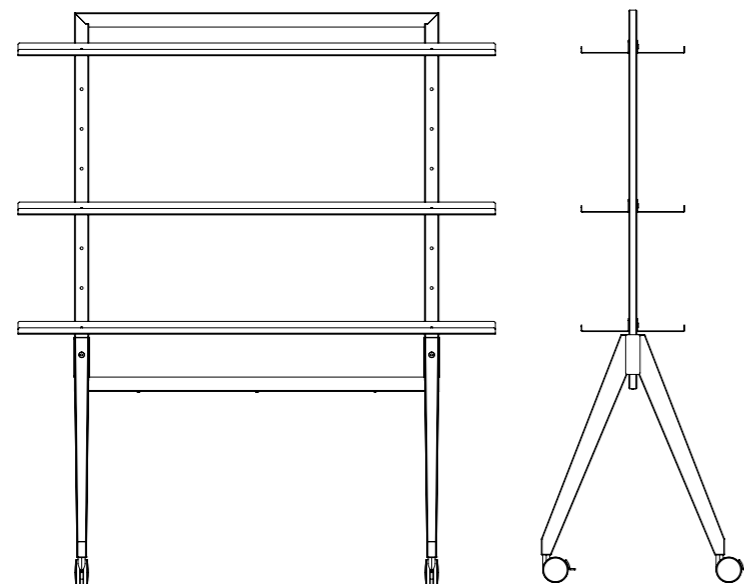

Article number	Castors
SF-LU-BK150.O.1	White
SF-LU-BK150.O.2	Black