

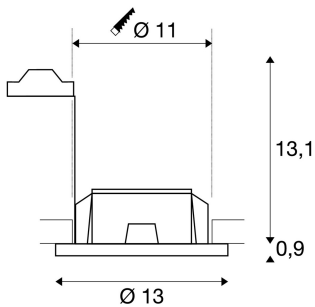

PLASTRA

recessed fitting, QPAR51, round, white plaster, max. 35W

With the PLASTRA recessed fitting, you have a highly-personalised plaster recessed luminaire with a puristic, clear shape. Prepared to take a GU10 halogen or retrofit LED bulb, it is ready for direct connection to the 230V mains supply. The sandpaper included as part of the delivery is used to clean the surfaces. After priming, the luminaire can be painted with wall paint as desired.



TECHNICAL DATA

Item no.:	148070
Socket	GU10
Lamp	QPAR51
Number of sockets	1
Lamps included	0
Primary nominal voltage	220-240V ~50/60Hz mA/V
Height	14.0 cm
Diameter	13.0 cm
Installation diameter	11.0 cm
Installation depth	13.5 cm
Net weight	0.527 kg
Gross weight	0.644 kg
Safety class	II
Assembly	Recessed
Assembly details	Ceiling
Wattage	35.0 W
BIG WHITE Page	453

Recommended lamp

1001918	VALETO® LED lamp , GU10, 2700-6500K, 48°, 5.1W
1001919	VALETO® LED lamp , GU10, RGBW, 60°, 5.6W

Notes
