

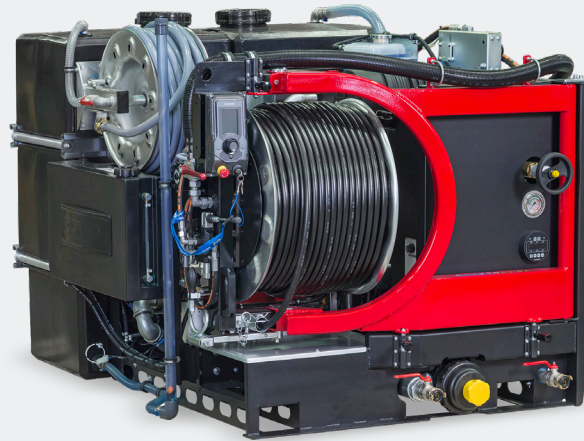

SPARTAN

FOR TOUGH CUSTOMERS.

SINCE 1943



PRODUCT MANUAL

Ultimate Urban Warrior Skid Mount Sewer Jetter

Spartan Tool LLC | 1506 West Division Street | Mendota, IL 61342
order by phone **800.435.3866** order online **SpartanTool.com**

© 2018 Spartan Tool LLC
Part #75730010



Contents

WARNINGS	4
FEATURES	5
DESCRIPTION—COMPONENTS	6
DESCRIPTION—CONTROLS	10
eController Functions	10
Corona Display	11
Push Buttons and Indicating Lights	11
Navigation Bullets	12
HP Hose Reel Mode	12
ECO Mode	12
Management Mode	13
Hose Counter (if equipped)	13
Tachometer	13
Remote Control	14
SAFETY INSTRUCTIONS	15
IMPORTANT SYMBOLS	17
MECHANICAL OPERATION	18
Check Before Departure	18
Placement of Ultimate Urban Warrior	18
Prior to Starting the Ultimate Urban Warrior	18
Starting the Engine	19
Manual Hose Reel Swivel Locking Device	20
Hydraulic Reel Control	21
High Pressure Hose Guide	21
Management Mode	22
ECONTROLLER OPERATION	22
ECO Mode	22
ECO Mode Operation	22
RIOMOTE® CONTROL OPERATION	23
Emergency Stop Test	23
Battery Indication	23

OPERATING INSTRUCTIONS 24

- Cleaning a Drain Line 24
- Stop Spraying 25
- Care of the HP Hose..... 25
- Cold Weather Operation 25
- Cleaning a Wall, Terrace, or Floor 26
- Secure After High-Pressure Cleaning 26

ECONTROLLER ERRORS..... 27

- Emergency Stop 27
- Engine Temperature 27
- Heat Exchanger High Temperature 27
- Hydraulic Oil High Temperature 28
- Oil Level..... 28
- Coolant Level..... 28
- Battery Charge 29
- Run Dry 29
- Service Interval 29

MAINTENANCE 30

- Daily Maintenance..... 30
- Minor Service..... 31
- Hydraulic System 32
- Engine Control Module 33
- Extensive Periodic Maintenance..... 33
- Maintenance Schedule..... 33

TECHNICAL SPECIFICATIONS 34

TROUBLESHOOTING 36

APPENDIX A: ENGINE CONTROL MODULE 38

APPENDIX B: MACHINE DIMENSIONS..... 41

APPENDIX C: ACCESSORIES 42



Warnings

- Read the safety and operating instructions before using any Spartan Tool product. Drain and sewer cleaning can be dangerous if proper procedures are not followed and appropriate safety gear is not utilized. Read the engine owners' manual for instructions and safety precautions on engine operation.
- Explosive fuel can cause fires and severe burns. Fuel is flammable and its vapors can ignite. Store fuel only in approved containers, in well ventilated, unoccupied buildings. Do not fill the fuel tank while the engine is hot or running, since spilled fuel could ignite if it comes in contact with hot parts or sparks from ignition. Do not start the engine near spilled fuel. Never use fuel as a cleaning agent.
- Before starting unit, be sure to wear personal protective equipment such as safety goggles or face shield and protective clothing such as gloves, coveralls or raincoat, rubber boots with metatarsal guards, and hearing protection.
- Ensure the jet hose has been placed in the pipe (minimum of 6 feet suggested) before engaging the water pressure to prevent the hose from coming out of the pipe prematurely and causing injury.
- Always shut off the water pressure before pulling the hose out of the pipe. Mark the hose a minimum of 6 feet from the end to help ensure the hose is not accidentally pulled out of the pipe while still under pressure. Shut off the water pressure when the hose mark is encountered.



CAUTION: Portions of the system can still be under pressure even if the unit is not operating.

- Never point the wash gun at anyone while operating the unit. Injury may result.
- Drains and sewer can carry bacteria and other infectious micro-organisms or materials which can cause death or severe illness. Avoid exposing eyes, nose, mouth, ears, hands, and cuts and abrasions to waste water or other potentially infectious materials during drain and sewer cleaning operations. To further help protect against exposure to infectious materials, wash hands, arms and other areas of the body, as needed, with hot, soapy water and, if necessary, flush mucous membranes with water. Also, disinfect potentially contaminated equipment by washing such surfaces with a hot soapy wash using a strong detergent.
- For any questions, contact Spartan Tool at the address shown below.

CONTACT US

Spartan Tool LLC
1506 West Division Street
Mendota, IL 61342
800.435.3866
SpartanTool.com



WARNING Breathing diesel engine exhaust exposes you to chemicals known to the State of California to cause cancer and birth defects or other reproductive harm.

- Always start and operate the engine in a well-ventilated area.
- If in an enclosed area, vent the exhaust to the outside.
- Do not modify or tamper with the exhaust system.
- Do not idle the engine except as necessary.

For more information go to www.P65warnings.ca.gov/diesel.



SPECS

- Pipe Sizes: up to 24" diameter
- Max Water Pressure: 4,000 psi
- Max Water Flow: 21 GPM
- Water Capacity: 320 gallons
- Unit Weight: 1,600 lbs (empty)
- Overall Size: 89"L x 54-3/8"W x 49-9/16"H
- Warranty: (1) year limited

FEATURES

- 65 HP Kubota T4 Diesel with DPF
- P55 Speck/Giant Triplex Pump
- eControl: LCD screen and easy-to-use jog-wheel for single click operation of machine
- LED display and warning lights provide machine status at a glance
- Pressure can be continuously adjusted with accessible handwheel
- Hose length counter
- Remote control
- 1/2" x 520' of Maxflow HP hose
- 115' of supply hose
- Pivoting and swiveling 270° hose reel, hydraulically operated with freewheel system
- ECO Package—saves fuel and prolongs engine life
- Powder-coated aluminum frame

SAFETY

- Run dry protection with override ability
- Automatic engine shutdown protection for high water temperature, engine temperature, low engine oil, or low engine coolant



Description—Components

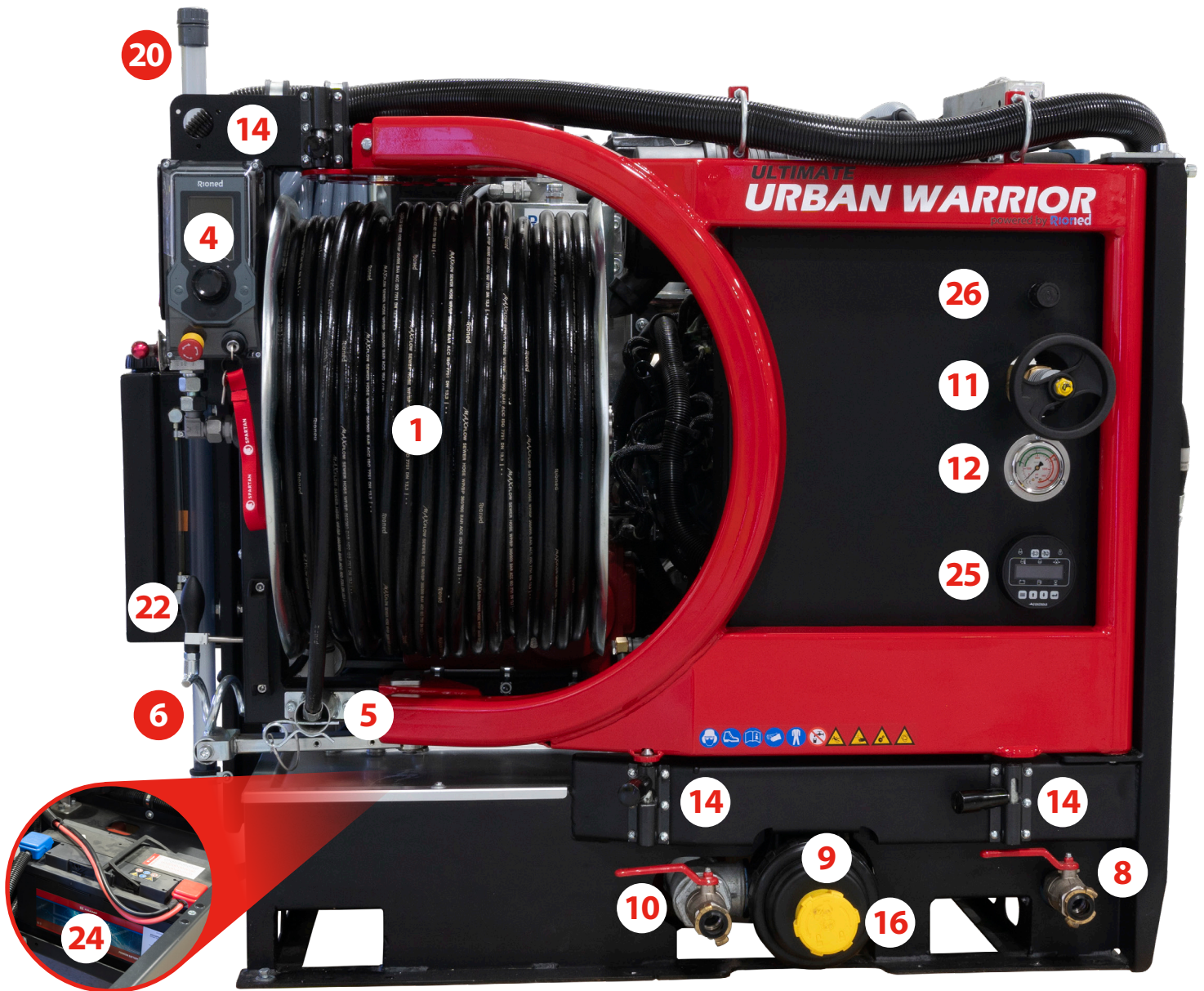

- | | | |
|-------------------------------|--------------------------------|---------------------------------------|
| 1. High-pressure hose on reel | 10. Drain valve | 19. Supply hose holder |
| 2. Supply hose on reel | 11. Pressure regulator | 20. Water tank level indicator |
| 3. Supply hose valve | 12. Pressure gauge | 21. Water tank |
| 4. eController | 13. Supply hose holder | 22. Fuel tank |
| 5. Hose holder | 14. Swivel Locking Device (3x) | 23. Engine |
| 6. Hose guide | 15. Supply hose reel lock | 24. Battery |
| 7. High-pressure (HP) valve | 16. Water filter valve | 25. ECM (Engine Control Module) |
| 8. Supply pipe | 17. HP pump | 26. Hydraulic Hose Reel Speed Control |
| 9. Water filter | 18. Hydraulic oil reservoir | |

Description—Components

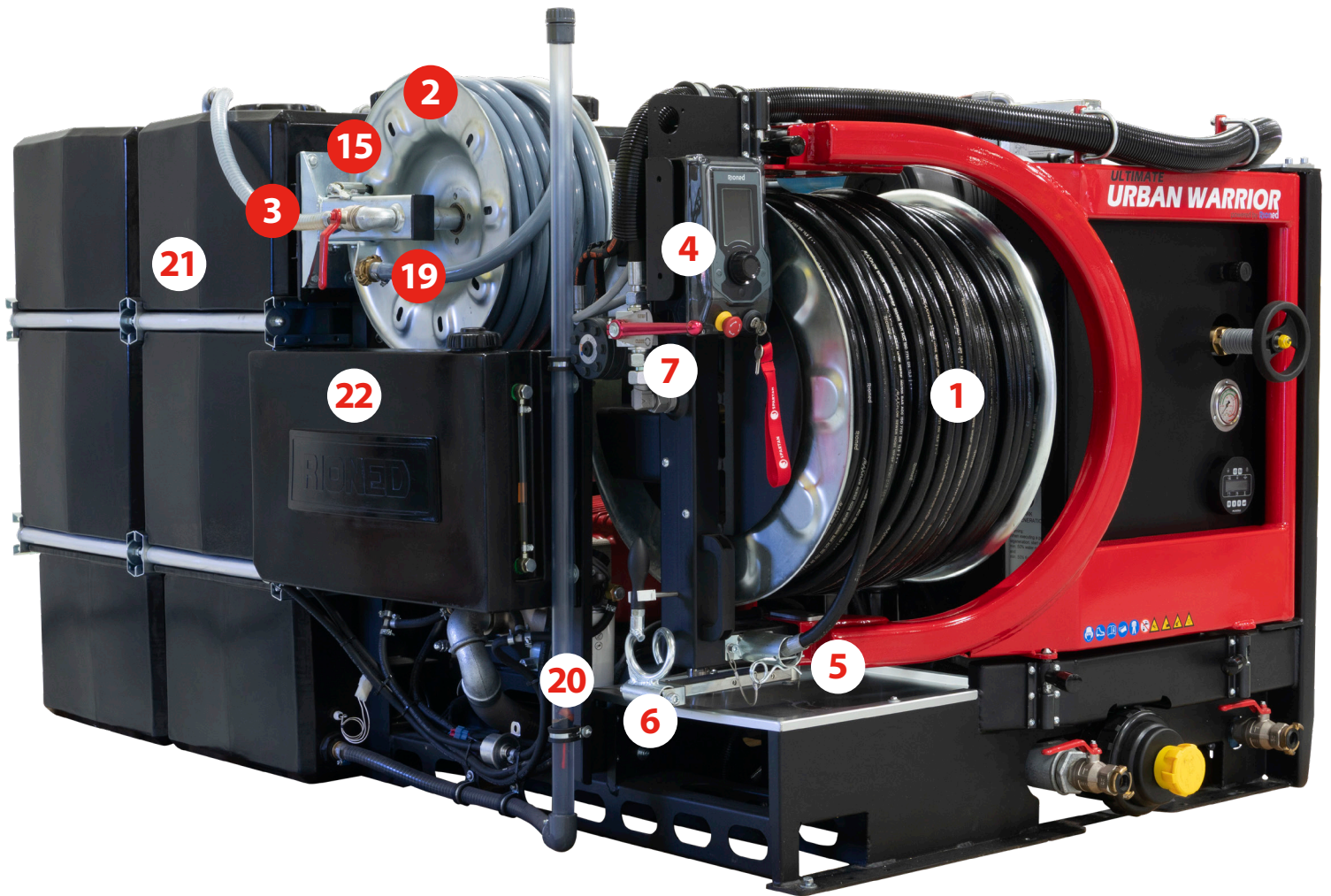

- | | | |
|-------------------------------|--------------------------------|---------------------------------------|
| 1. High-pressure hose on reel | 10. Drain valve | 19. Supply hose holder |
| 2. Supply hose on reel | 11. Pressure regulator | 20. Water tank level indicator |
| 3. Supply hose valve | 12. Pressure gauge | 21. Water tank |
| 4. eController | 13. Supply hose holder | 22. Fuel tank |
| 5. Hose holder | 14. Swivel Locking Device (3x) | 23. Engine |
| 6. Hose guide | 15. Supply hose reel lock | 24. Battery |
| 7. High-pressure (HP) valve | 16. Water filter valve | 25. ECM (Engine Control Module) |
| 8. Supply pipe | 17. HP pump | 26. Hydraulic Hose Reel Speed Control |
| 9. Water filter | 18. Hydraulic oil reservoir | |

Description—Components

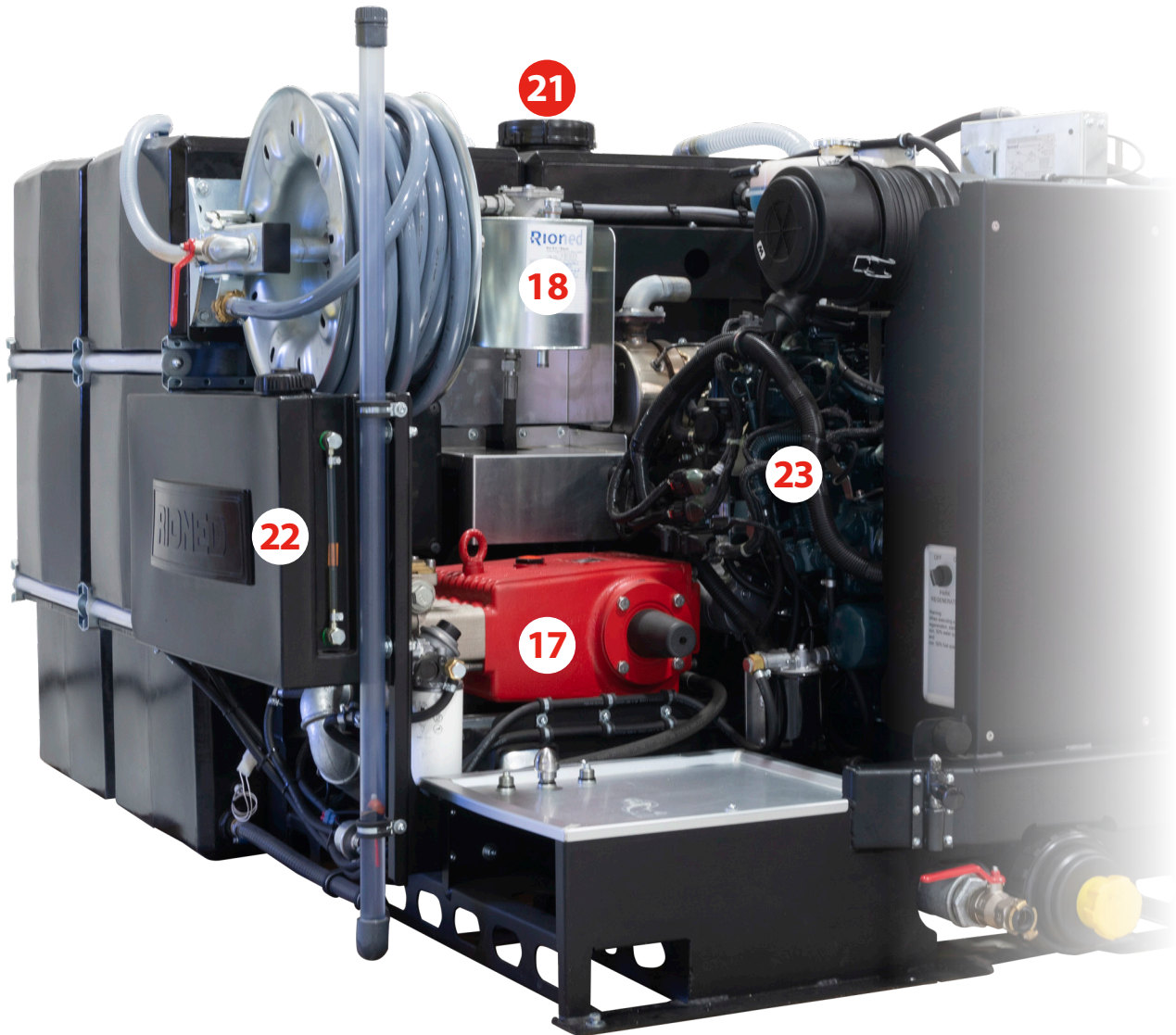

- | | | |
|-------------------------------|------------------------------------|---------------------------------------|
| 1. High-pressure hose on reel | 10. Drain valve | 19. Supply hose holder |
| 2. Supply hose on reel | 11. Pressure regulator | 20. Water tank level indicator |
| 3. Supply hose valve | 12. Pressure gauge | 21. Water tank |
| 4. eController | 13. Supply hose holder | 22. Fuel tank |
| 5. Hose holder | 14. Swivel Locking Device (3x) | 23. Engine |
| 6. Hose guide | 15. Water tank | 24. Battery |
| 7. High-pressure (HP) valve | 16. Water filter valve | 25. ECM (Engine Control Module) |
| 8. Supply pipe | 17. HP pump | 26. Hydraulic Hose Reel Speed Control |
| 9. Water filter | 18. Hydraulic oil reservoir | |

CONTROLS AND INDICATIONS

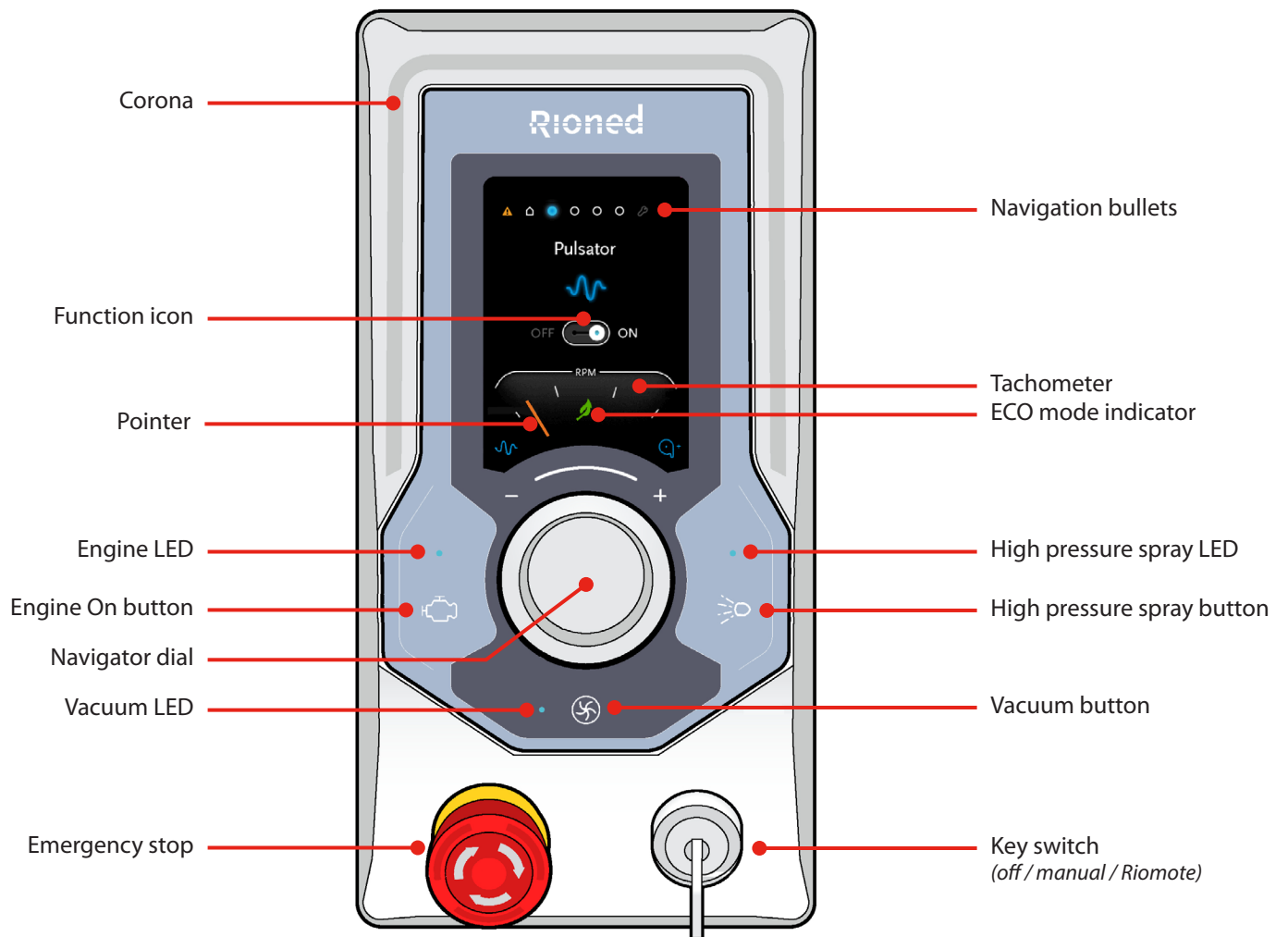



Description—Controls

ECONTROLLER FUNCTIONS

Spartan Tool provides several options on the Ultimate Urban Warrior skid mount sewer jetter. As a result, there are multiple eControl configurations to accommodate the features available on any particular unit.

This section of the manual will cover available functions of the Two Function eController and the Four Function eController.

The two figures below identify the Two Function and Four Function eController.



2 FUNCTION ECONTROLLER

The two function remote is identified by the **two blue function indicators** at the top of the LCD display.

The two functions are:

- Home function
- Maintenance function



4 FUNCTION ECONTROLLER

The four function remote is identified by the **four blue function indicators** at the top of the LCD display.

The four functions are:

- Home function
- HP hose reel control
- ECO mode
- Management function

CORONA DISPLAY

The Corona on the eController is normally off (gray).



Blue corona indicates set to **Riomote Control**

Red corona indicates **eController error**

See page 27 (eController Errors) for alarm functions

Orange corona indicates **pre-start functions** or one of two **error conditions**:

- Run dry (no water in tank)
- Error oil level

Green corona indicates **switched off by ECO start/stop system**

PUSH BUTTONS AND INDICATING LIGHTS

- The **Engine On** light/button indicates the status and controls the starting of the engine. (See page 19, *Starting the Engine*, for more information.)
- The **High Pressure Spray** light/button indicates the status and controls the high pressure spray valve. (See page 24, *Cleaning a Drain Line*, for more information.)

The **Blue LED** above each button will **blink** when the corresponding function is available. (The engine is ready to start or high pressure spray is available.)

The **Blue LED** above each button will **light solid** when the corresponding function is active. (The engine is running or the high pressure spray valve is open.)

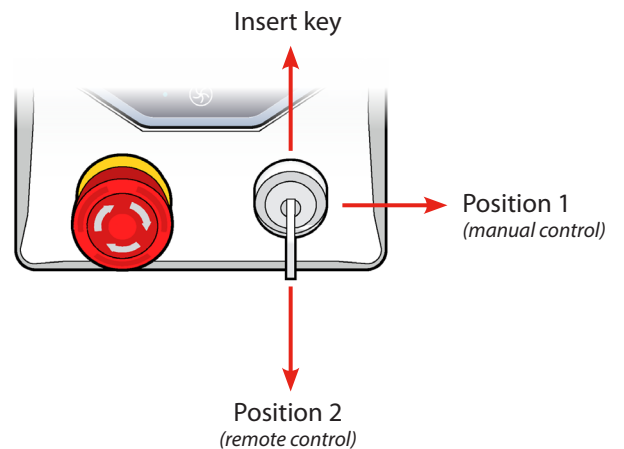

Description—Controls

NAVIGATION BULLETS

The navigation bullets have two general states:



Passive (gray)



Active (blue)

Depending on the user's location in the menu, one bullet is on display, or in the case of a pop-up eController error, all navigation bullets disappear. (See page 27, *eController Errors*, for a list of pop-up displays.)

Features in navigation bullets are in specified order, if applicable:

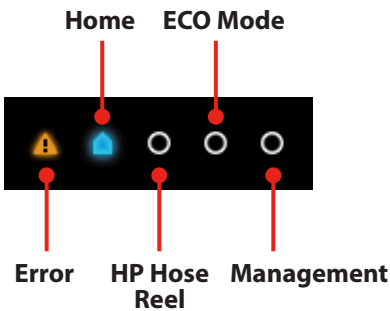

The **Error** navigation icon is only visible and can be navigated when an error is applicable.



The **Home** navigation icon is the default position and normally displays engine run time and HP hose counter.

ECONTROLLER FUNCTIONS

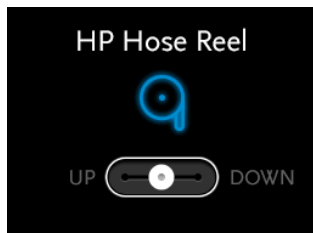

HP Hose Reel Mode

When the eController is set to **HP Hose Reel** the LCD displays the hose position and the up/down control positions. The hose reel is actuated by rotating the Navigator dial clockwise to select **down** and counter clockwise to select **up**. Depress the Navigator dial to select the action.

The speed of the hydraulic drive using the eController is controlled by adjusting the speed control unit which throttles the hydraulic flow to the reel drive hydraulic motor. (See page 21, *Rewind Hose Using Hydraulic Reel*.)



Hydraulic Speed Control

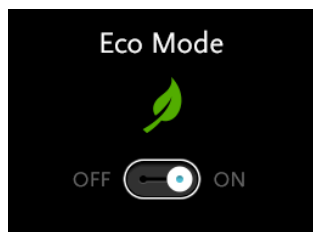

ECO Mode

When the eController is set to ECO Mode, the LCD displays the status of ECO Mode, either ON or OFF. The default is **ECO Mode on** whenever the engine is started. The green leaf icon on the tachometer display is lit when the ECO Mode is active.

In ECO Mode, the eController controls the high pressure valve and the speed of the engine during periods when flow is not being used. If there is no operator action being taken, the engine will eventually shut down.

(See page 22 in the *eController Operation* section for a more detailed description of ECO Mode operation.)

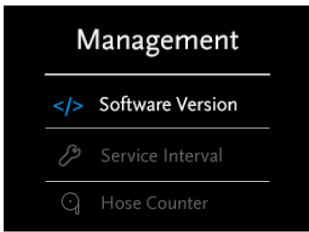

Management Mode

When the eController is set to Management Mode, the LCD displays a menu of three functions that can be selected by rotating the Navigator dial and activated by depressing the navigation knob.

- **Software Version** displays the current version of the controller software.
- **Service Interval** displays the days and run hours until maintenance is required.
- **Hose Counter** displays the length of hose off the HP hose reel.

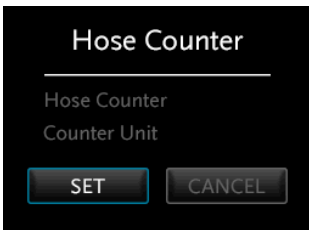

Hose Counter (if equipped)

When the eController is set to Hose Counter mode, the LCD displays a menu of two functions that can be selected by rotating the Navigator dial and activated by depressing the navigation knob.

- **Hose Counter** allows the user to select on or off.
- **Counter Unit** allows the user to select meters or feet.



Tachometer

The pointer indicates the engine's current RPM.

Description—Controls

REMOTE CONTROL

Hand-Held Remote Sender

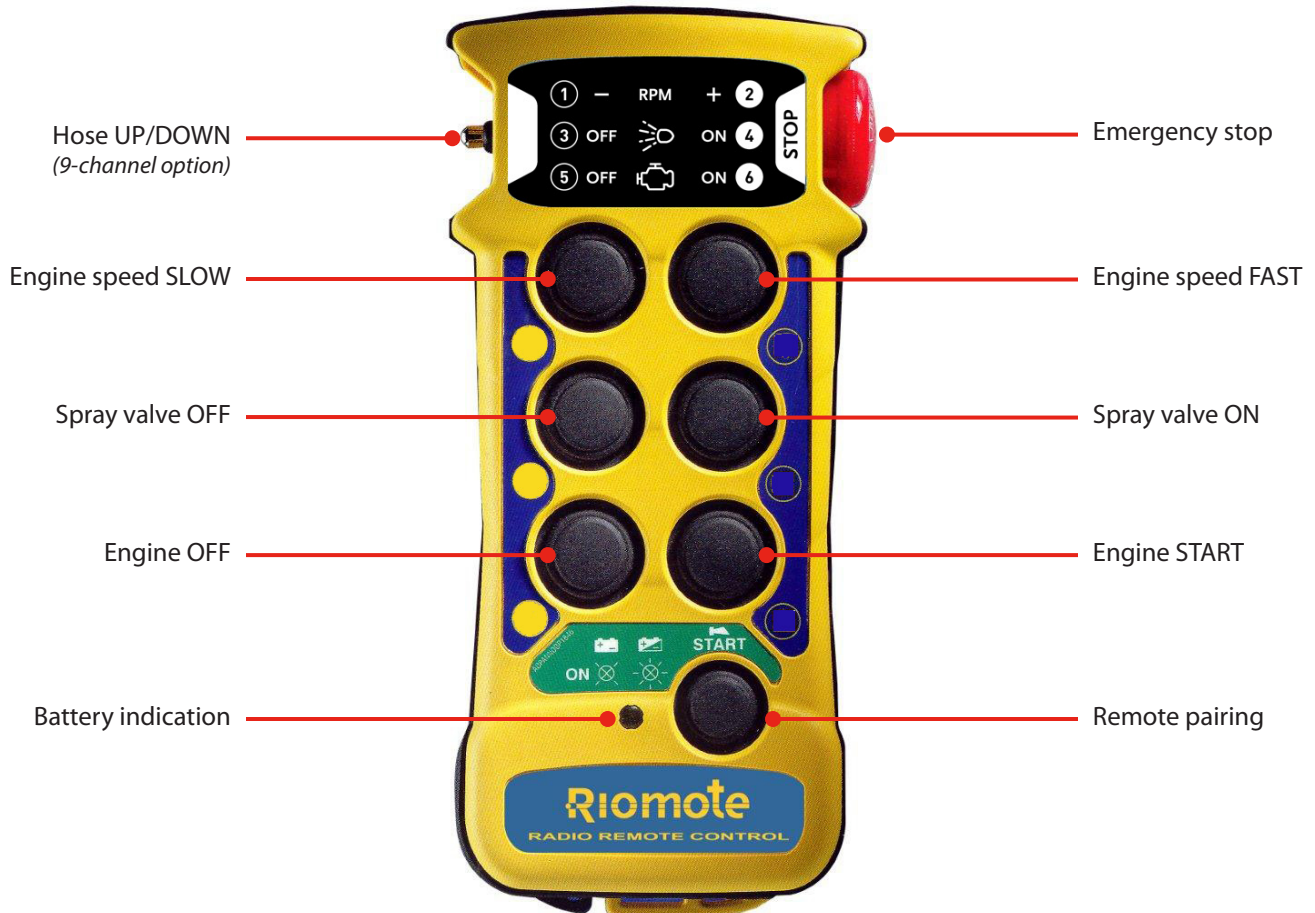

The **Riomote® radio remote control** consists of a large waterproof and shockproof hand-held sender and a unit-mounted receiver. The system is provided with separate batteries (8 hours per charge) and is supplied with a battery charger. The Riomote® radio remote control is available in 7-channel and 9-channel models dependent on the functions available on the eController.

UNIT-MOUNTED RECEIVER





WARNING: Read the **Operator's Manual** thoroughly before using any Spartan Tool product. Drain and sewer cleaning can be dangerous if proper procedures are not followed. Know the proper operation, correct applications for your Spartan Tool products.

EMERGENCY STOP

This machine is equipped with an **Emergency Stop**. By operating the Emergency Stop, the machine will shut down. Do not use this button for normal stopping. Only use it when dangerous situations occur. After use, remove the danger and then rotate the Emergency Stop button clockwise to be able to start up again. Ensure the Emergency Stop can always be reached.

PRESSURE REGULATOR

The **Pressure Regulator** functions to ensure that the working pressure never gets too high. It functions like a safety valve, relieving water to the storage tank to reduce pressure in the HP hose line.

PERSONAL PROTECTIVE EQUIPMENT

The following personal protective equipment should be worn by personnel operating or working with the Ultimate Urban Warrior:

- Ear protection
- Protective safety glasses or goggles
- Gloves (recommended)
- Waterproof work clothing (recommended)
- Spray boots for use with the spray gun (recommended)

WORK AREA

The following precautions must be observed when establishing a work area for use of the Ultimate Urban Warrior:

- Clearly mark the work area.
- Maintain a minimum distance of 20 feet from the work area.
- Remove all loose materials from inside the work area.
- Never spray from an unstable surface (ladder, boat, scaffold, etc.).
- Never use in a confined space (closed room).
- Ensure there are no combustible materials in the area.
- The area must be adequately ventilated to prevent accumulation of carbon monoxide.
- DO NOT use corrosive chemicals in conjunction with Spartan Tool sewer jetters. Only environmentally-approved chemicals should be introduced into drain lines.

Safety Instructions

GENERAL PRECAUTIONS

- Do not let the machine operate without supervision.
- Keep children and animals away from the machine.
- DO NOT spray on humans or animals. *If the skin is penetrated, immediately seek medical attention.*
- Prevent damage from debris or flying parts.
- Avoid spraying near electrical connections and other electric components if you are cleaning with a spray gun.
- Never block the controls in any way.
- Put personal protective equipment on BEFORE you start the machine.
- Ensure that the spray nozzle does not leave the drain.



SAFETY STICKERS

1. Safety glasses, hard hats , and hearing protection are required
2. Safety shoes are required
3. Be familiar with the user's manual
4. Hand protection is required
5. Wear protective clothing against caustic material
6. No eating or drinking
7. Slipping hazard
8. Pinching hazard (hand injury)
9. Rotating machinery
10. Warning, machine auto start



ULSD

Ultra Low Sulfur Diesel

ULTRA-LOW SULFUR DIESEL

This machine is designed to run on diesel fuel with ultra-low sulfur content (15 ppm).



PARK REGENERATION

Excess idling or low RPM operation will build up soot and ash in the engine, causing a loss of power and may cause the engine to stall.

An indicator lamp on the Engine Safety Protection Panel will illuminate to indicate when manual engine regeneration is required by placing the unit in neutral parking mode.

(See page 43, Emissions Monitoring and Regeneration for more information.)

PRESSURE GAUGE

Operating Zone

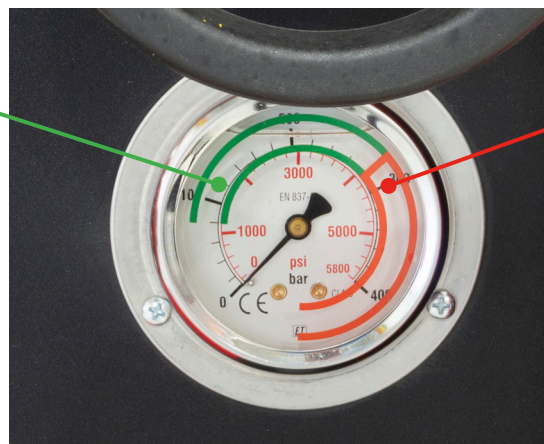

Danger Zone

The mechanical relief in the unloader valve will prevent pressure from exceeding 4000 PSI.



WARNING If the unit fails to maintain pressure within the operating zone, contact Spartan Tool Customer Service at 800.435.3866 or by email at CustomerService@SpartanTool.com.



Mechanical Operation

CHECK BEFORE DEPARTURE

Before you drive away with the vehicle, check the following:

1. The high-pressure hose has been inserted into the hose holder (5) and secured with the locking pin.
2. The high-pressure hose reel is locked with the clutch engaged (30) (see page 21) and the manual hydraulic hose reel control lever is in the neutral position, or the eController is not in Hose Reel mode. (See page 21, *Hydraulic Hose Reel Control*, for more information.) The HP reel swing arm is locked in place with latches (14).
3. The supply hose is connected to the supply hose holder (19). The supply hose reel is locked by means of the reel locking device (15).
4. If temperatures are below freezing, the water tank should be emptied and the piping system drained and flushed with antifreeze. (See page 25, *Cold Weather Operation*, for more information.)
5. The vehicle is now ready for departure.

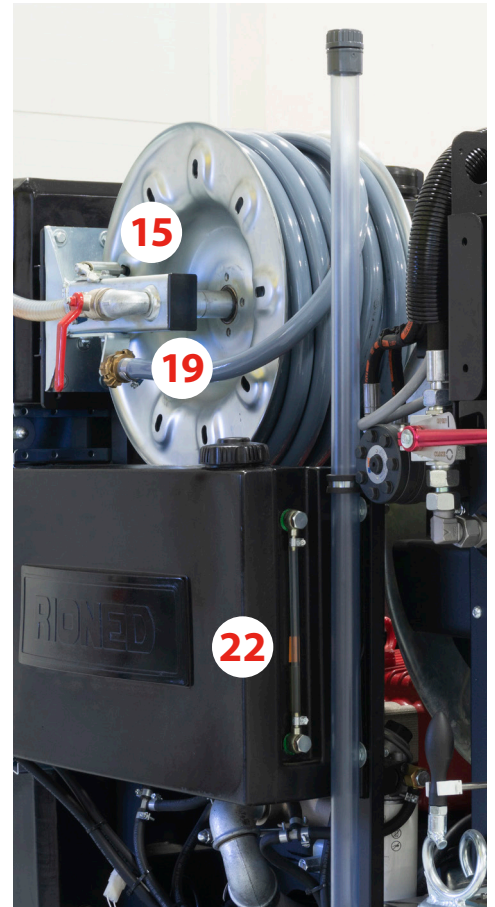
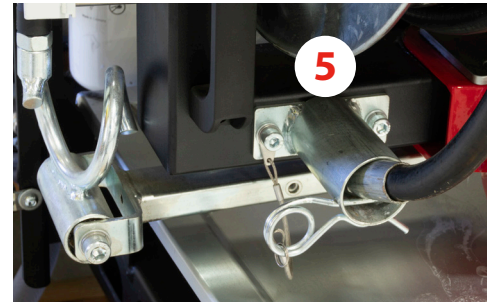

PLACEMENT OF ULTIMATE URBAN WARRIOR

1. Put the vehicle at the desired location and set the parking brake.
2. Block the tires if using on an incline or uneven surface.
3. Mark the working area by establishing barriers to prevent inadvertent access to the work area.

PRIOR TO STARTING THE ULTIMATE URBAN WARRIOR

1. Ensure there is adequate fuel in the fuel tank (22) for the intended task.
2. Ensure the water filter (9) is clean. Clean the filter, if necessary.
3. Check that the supply valve (16) to the water filter is open.
4. Check that the high-pressure valve (7) at the HP hose reel is closed.
5. Fill the water tank via the supply pipe (8) or the supply hose. (The maximum water temperature is 55°C.)
6. Loosen the control wheel of the pressure regulator (11) (rotate counter-clockwise).
7. Attach the jetting nozzle onto the high-pressure hose.

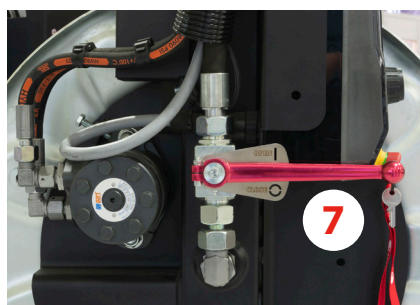

STARTING THE ENGINE



IMPORTANT! The machine is equipped with an **Emergency Stop**. By operating this Stop, the machine will shut down. Do not use this button for normal stopping. Only use when dangerous situations occur. After use, rotate the Emergency Stop clockwise to be able to start again. Make sure the Emergency Stop can always be reached.



CAUTION! Put on protective safety goggles and ear protection before starting the machine.

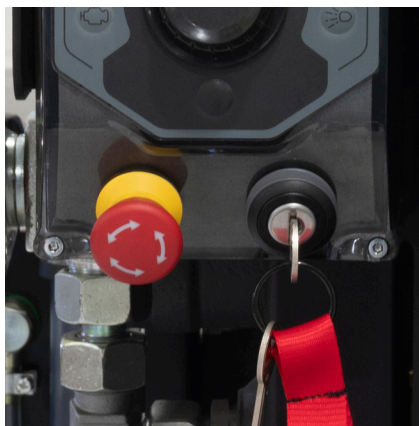

1. Put the key in the eController key switch.

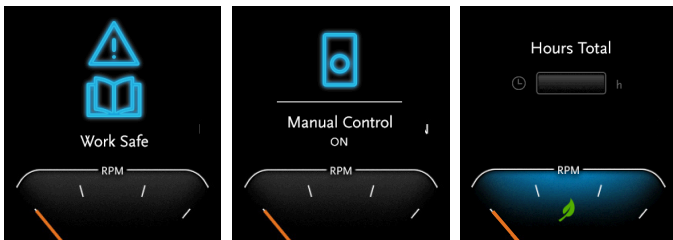

2. Turn the key clockwise to position 1, **Manual Control on**.

- **Work Safe** is displayed for 2 seconds.
- Icon **Manual Control on** is displayed for 2 seconds.
- Then the main menu is displayed.
- ECO mode is always active ECO Start/Stop or ECO Stop if the unit is supplied with the ECO Function.

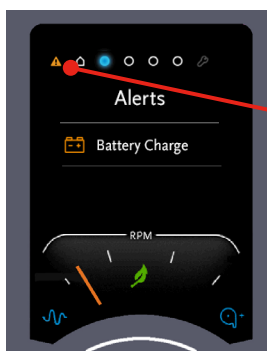

3. Check the **Error icon**.

- If the error icon is visible, then check the **eController Error icon**. (See page 27 for a description of eController Errors.)

Mechanical Operation



A

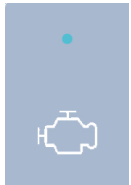

38



39

- If the error icon is not visible, depress the **Engine On** button for two seconds.
 - Pre-heat** (A) lights energize for 5 seconds.
 - After 5 seconds, the engine starts.
 - With the engine running, the blue **Engine LED** light (38) and the **Engine On** light (39) is displayed for 2 seconds.
 - The main menu on the eController is displayed after 5 seconds.

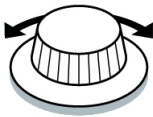

- Increase (clockwise) or decrease (counter clockwise) RPM by turning the Navigator dial.

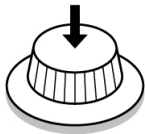

- Depress the Navigator dial to display the **Navigation Bullet** menu.
 - Let the engine warm up. After 3 minutes, the machine is ready for use.
 - Press the **Engine On** button (39) to adjust RPMs with the Navigator dial.

MANUAL HOSE REEL SWIVEL LOCKING DEVICE

There are three locking mechanisms associated with the high pressure hose reel arm.

- Mechanism A** should normally be disengaged when the hose reel arm is in the stored position. Mechanism A is for locking the arm in place when in an extended position.
- Mechanism B** is a spring returned latching device that must be pushed down to unlock the arm and allow extending the hose reel arm. Once positioned, the arm must be locked in place by engaging Mechanism A.
- Mechanism C** is disengaged by pulling up on the mechanism to allow the hose reel to be positioned with the hose reel arm. Once positioned, releasing Mechanism C will lock the reel in place within the hose reel arm.



HYDRAULIC REEL CONTROL *(if equipped)*

The hydraulic control lever is spring loaded to default to the **Neutral Position (A)** where the hose reel is locked by the hydraulic actuator.

- Pushing the control lever **up** (position B) will actuate the hydraulic motor to wind the hose onto the reel.
- Pushing the control lever **down** (position C) will actuate the hydraulic motor to unwind the hose off the reel.
- Due to the proportional functioning of this valve you can control the speed of the reel by movement of the lever away from the **center position (A)**.
- Pushing the control level into **position D**, (a maintaining position) will allow the hose reel to move without the aid of the hydraulic motor. This allows the hose to unwind as the high pressure hose nozzle works its way through a drain line.

A **clutch assembly (30)** on the HP hose reel drive unit can be disengaged to allow the hose reel to free wheel for pulling the hose off the reel manually.

The **hydraulic speed control knob (26)** can be adjusted to control the range of speed when using the hydraulic reel control lever. (This feature is only available on model equipped with the 9-channel remote.)

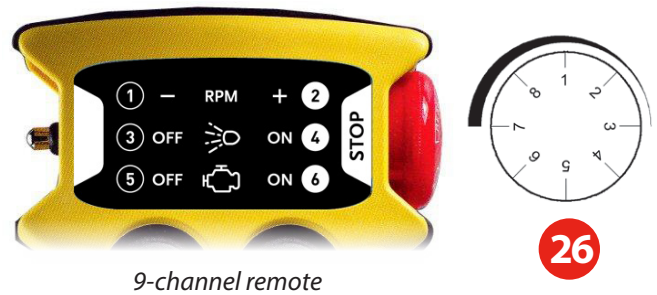

9-channel remote

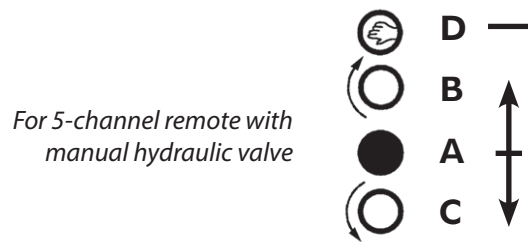
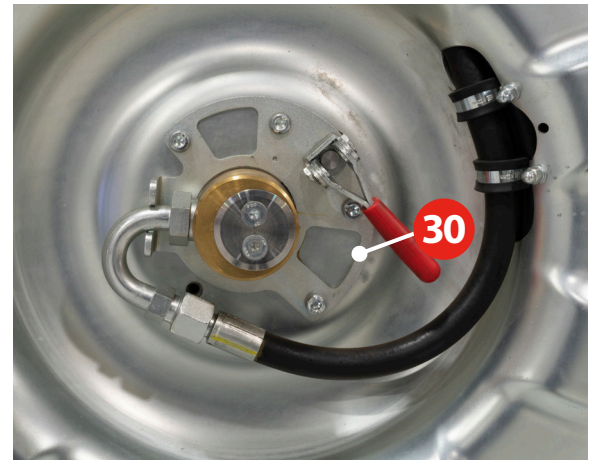

WARNING! Never block the Hydraulic Hose Reel lever and always control it with one hand while guiding the high-pressure hose by means of the hose guide.

HIGH PRESSURE HOSE GUIDE

The purpose of the **High-Pressure Hose Guide** is to guide the HP hose onto and off of the hose reel.

- Put the end of the HP hose through the opening of the hose guide (6).
- Moving the hose guide right and left guides the hose evenly on the hose reel.





eController Operation

ECO MODE

ECO Mode is available if the unit is supplied with a Four Function eController. ECO Mode functions to close the HP valve and reduce engine RPM during periods of inactivity sensed by low spray flow.

To change or disable ECO Mode, the engine must be running.

ECO Mode defaults to **on** when the engine is started. When the ECO Mode is on, the ECO Mode icon (green leaf) is illuminated and the ECO function is active.

To turn the ECO Mode **off**, select the ECO Mode function using the Navigator dial and depress the Navigator dial to activate the ECO Mode function.

- Once activated, turn the Navigator dial counter clockwise to select **off** and depress the Navigation dial to activate ECO Mode **off**.
- ECO Mode icon (green leaf) extinguishes.

To turn the ECO Mode **on**, turn the Navigator dial clockwise and depress the Navigator dial to activate.

- ECO Mode is on.
- ECO Mode icon (green leaf) illuminates.

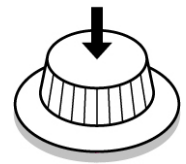
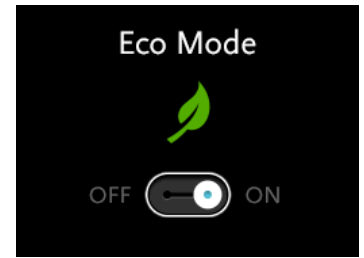

ECO MODE OPERATION

- High Pressure valve closes.
- Engine RPM decreases.
- Engine stops after 30 seconds with no operator action.
- To restart, press the **Engine Start** button.
- Press the **High Pressure On** button.
- Water comes out of the high-pressure hose.
- Increase engine RPM to adjust pressure and water flow.

MANAGEMENT MODE

Management Mode functions to display the current software version, required service intervals, and the hose reel counter.

1. Rotate the Navigator dial to set the navigation bullet to **position 4, Management**.
2. Depress the Navigator dial to activate the Management function.
 - The Navigation bullet extinguishes.
 - The Management underline illuminates.
3. Once the Management function is activated, the three menu options are displayed which include: Software version, Service interval and Hose counter.
4. Each menu item can be displayed by selecting the item with the Navigator dial and depressing the dial to activate the selection.

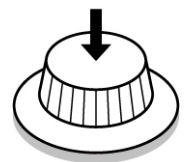



RIOMOTE® CONTROL

The **Riomote® remote control** provides the ability to operate the high pressure machine jetter from a distance. There are multiple versions of the remote control based on the available functions of the machine.

EMERGENCY STOP TEST

Check that the emergency stop works before working with the Riomote® control. Proceed as follows:

1. Insert the key into the **eController key switch**.
2. Turn the key to **position 2, Remote Control on**.
 - **Work Safe** is displayed for 2 seconds.
 - **Riomote® Control on** is displayed continuously.
 - Corona illuminates blue and is blinking.
3. Switch the Riomote® control **on**.
 - Press and hold the **Start button** on the Riomote® to link the Riomote® with the Ultimate Urban Warrior.
 - Release the **Start button** when the blue corona stops blinking.
 - Corona illuminates continuous blue when the Riomote® control is in contact with the receiver.
4. Start the engine using **Engine Start button** on the Riomote® control.
5. Depress the **Stop button** to exercise the Emergency Stop function.

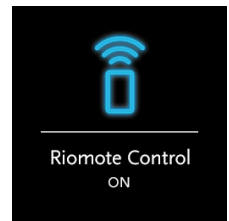

BATTERY INDICATION

If the **Battery indicator** on the Riomote control lights continuously, the battery must be recharged.



NOTE! The engine will shut down if the remote is out of range or the battery loses charge.



NOTE! If the engine does NOT stop by using the Riomote® control, contact Spartan Tool Customer Service.



Operating Instructions

CLEANING A DRAIN LINE

1. Attach a suitable nozzle onto the high-pressure hose.
2. With the hose reel out of gear (Position D, page 21), pull the hose through the **hose guide** (6) to facilitate guiding the hose.
3. The hose can be unwound short distances with the hydraulic hose reel out of gear.
4. Put the nozzle into the drain to be cleaned (a minimum of 6 feet).
5. Rotate the **pressure regulator** (11) clockwise to increase pressure to the desired value on the pressure gauge (12).
6. Open the **high-pressure valve** (7).
7. Depress the **high pressure on button** (35).
 - Water begins spraying out of the nozzle at the end of the hose.
 - **High pressure LED** (33) lights blue.
 - **High Pressure On** is displayed on the eController screen for 2 seconds.
 - After 5 seconds, **Main Menu** is displayed on the eController screen.
8. Increase or decrease engine RPM by turning the **Navigator dial**.
9. The hose will now unwind and work its way into the drain line.
10. When possible, jet the drain line from the low end to the high end of the pipe.
11. Check for water draining away as an indication that the blockage has been cleared in the drain line.
12. When the blockage has been cleared, continue to flush the pipe while rewinding the high-pressure hose.

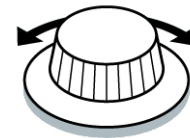
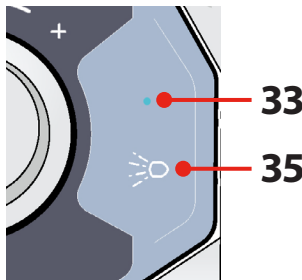
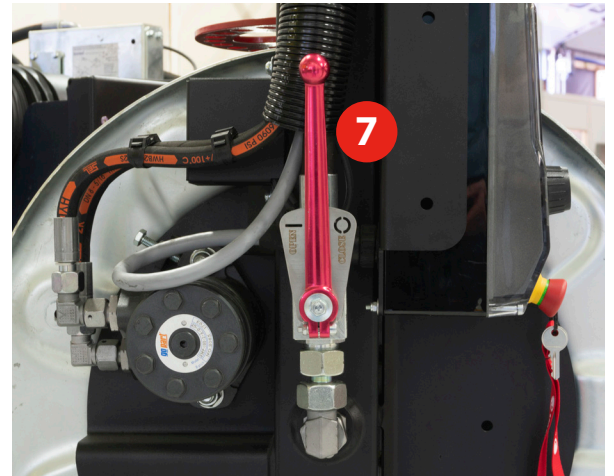

Navigator dial

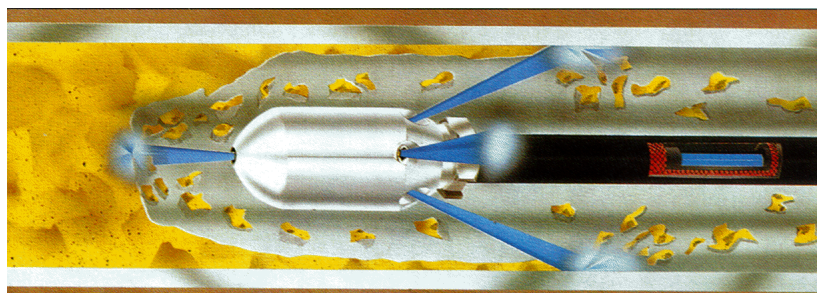



ATTENTION! Ensure that the spraying nozzle does not leave the drain while spraying. Water under high pressure may cause severe injury.

STOP SPRAYING

Depress the **high pressure button** (35) to shut the high pressure valve.

- The **high pressure LED** (33) extinguishes.
- **High Pressure Off** appears on the eController display for 2 seconds.
- Water spray at hose nozzle stops.
- Engine RPM decreases.
- Close the **high pressure valve** (7).

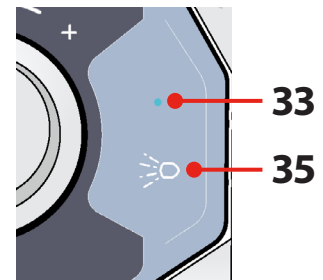

CARE OF THE HP HOSE

- Always clean the hose after use.
- Ensure there are no sharp objects near the hose.
- Ensure vehicles do not cross over the hose.



IMPORTANT! Rewind hose onto reel under pressure to avoid crushing. If machine has run out of water, ensure hose is unwound before pressurizing.

COLD WEATHER OPERATION

Your high-pressure device may freeze up in cold weather and temperatures below 32°F. A number of safety precautions must be taken.

Additional preparations before departure:

1. Drain the water tank by opening the drain valve.
2. When all the water has been removed or drained, remove the water filter.
3. Clean the filter and mount it in opposite order.
4. Close the drain valve.
5. Remove the nozzle/gun from the HP hose.
6. Antifreeze unit with optional Antifreeze System.

Operating Instructions

CLEANING A WALL, TERRACE, OR FLOOR



CAUTION! Before using a spray gun, set the jetter pressure below the maximum spray gun pressure (+/- half the maximum spray gun pressure). Do this prior to starting the engine. Once the engine is running, jetter pressure can be increased by turning the HP regulator handwheel to the working pressure. DO NOT exceed the green band pressure on the pressure gauge.

1. Attach the **spray gun** (B) onto the high-pressure hose.
2. Disengage the **clutch** and completely unroll the **high pressure hose**.
3. Attach the **spray lance gun** (C), securing the quick coupling tightly.
4. Open the **manual HP valve** (7).
5. Depress the **High Pressure On button**.
6. Throttle up the engine speed by rotating the **Navigator dial** clockwise.
7. Rotate the **pressure regulator hand wheel** (11) clockwise until the desired operating pressure is reached when the spray gun is open.

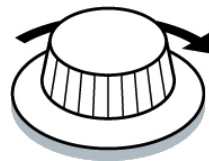
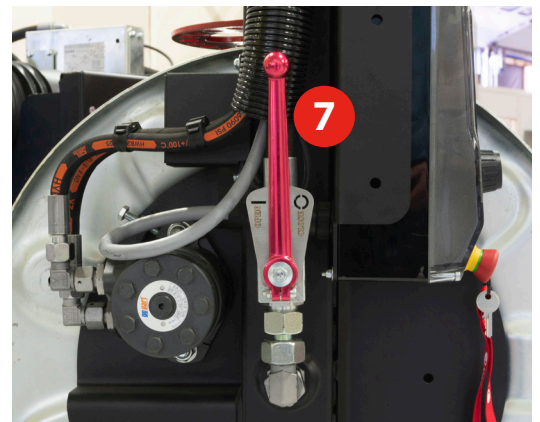

SECURE AFTER HIGH-PRESSURE CLEANING

1. Depress the **high pressure button** (35) to shut the high-pressure valve and throttle down the engine.
2. Close the **manual high pressure valve** (7).
3. Depress the **Engine On button** (34) for more than 1 second to stop the engine.
4. Rewind the hose.

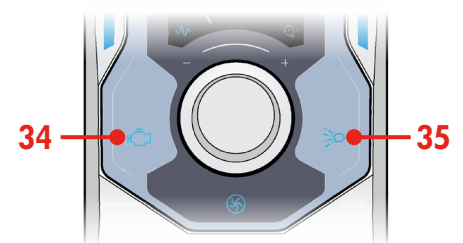

IMPORTANT! Rewind hose onto reel under pressure to avoid crushing. If machine has run out of water, ensure hose is unwound before pressurizing.



EMERGENCY STOP

1. The **Emergency Stop icon** illuminates on the eController when the Emergency Stop button is depressed.
 - Engine stops
 - High pressure valve closes
 - Pulsator valve closes (if equipped)
 - Hose reel switches off
 - ECO Mode switches on
2. Operation can only be restarted after rotating the Emergency Stop button to release it.



ENGINE TEMPERATURE

1. The **Engine Temperature icon** illuminates when high engine temperature is detected (240° F).
 - Engine stops
 - High pressure valve closes
 - Pulsator valve closes (if equipped)
 - Hose reel switches off
 - ECO Mode switches on
2. The operator can acknowledge the alarm display by depressing the Navigator dial in Manual Mode.
3. Operation can only resume after engine temperature has cooled to clear the alarm.



HEAT EXCHANGER HIGH TEMPERATURE

1. The **Heat Exchanger High Temperature icon** illuminates when high temperature is detected.
 - Engine stops
 - High pressure valve closes
 - Pulsator valve closes (if equipped)
 - Hose reel switches off
 - ECO Mode switches on
2. The operator can acknowledge the alarm display by depressing the Navigator dial in Manual Mode.
3. Operation can only resume after heat exchanger temperature has cooled.



HYDRAULIC OIL HIGH TEMPERATURE

1. The **Hydraulic Oil Temperature icon** illuminates when high hydraulic oil temperature is detected.
 - Engine stops
 - High pressure valve closes
 - Pulsator valve closes (if equipped)
 - Hose reel switches off
 - ECO Mode is unchanged
2. The operator can acknowledge the alarm display by depressing the Navigator dial in Manual Mode.
3. Operation can only resume after the hydraulic oil temperature has cooled.



OIL LEVEL

1. The **Oil Level icon** illuminates when low engine oil level is detected.
 - Engine stops
 - High pressure valve closes
 - Pulsator valve closes (if equipped)
 - Hose reel switches off
 - ECO Mode is unchanged
2. The operator can override the alarm display by depressing the Navigator dial in Manual Mode and continue operation.



COOLANT LEVEL

1. The **Coolant Level icon** illuminates when low engine coolant level is detected.
 - Engine stops
 - High pressure valve closes
 - Pulsator valve closes (if equipped)
 - Hose reel switches off
 - ECO Mode is unchanged
2. The operator can acknowledge the alarm display by depressing the Navigator dial in Manual Mode.
3. The operator must refill the coolant level in order to restart the engine.



BATTERY CHARGE

1. The **Battery Charge icon** illuminates when low battery voltage is detected.
 - Engine stops
 - High pressure valve closes
 - Pulsator valve closes (if equipped)
 - Hose reel switches off
 - ECO Mode is unchanged
2. The operator can override the alarm display by depressing the Navigator dial in Manual Mode and continue operation.



RUN DRY

1. The **Run Dry icon** illuminates when low level is detected in the water tanks.
 - Engine stops
 - High pressure valve closes
 - Pulsator valve closes (if equipped)
 - Hose reel switches off
 - ECO Mode is unchanged
2. The operator can override the alarm display by depressing the Navigator dial in Manual Mode and continue operation.
3. The **High-Pressure LED** starts blinking when the run dry is active. The override remains active as long as the Navigator dial is depressed.

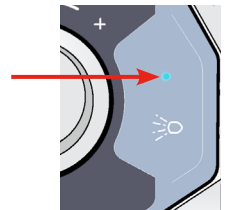

SERVICE INTERVAL

1. The **Service Interval icon** illuminates when any of the maintenance intervals have been exceeded. The error is also listed under the Management function on the eController.
 - Engine stops
 - High pressure valve closes
 - Pulsator valve closes (if equipped)
 - Hose reel switches off
 - ECO Mode is unchanged
2. After running 360 days or 250 hours (whichever comes first), the error message is displayed.
3. The operator can override the message by depressing the Navigator dial in Manual Mode.
4. The message will reappear the next time the machine is started.



Maintenance



CAUTION! Always stop the engine first and depressurize the system before servicing or repairing the machine. To depressurize the system, open the manual HP valve. If the spray gun is attached, you must also pull the trigger to release the pressure.

DAILY MAINTENANCE

Check Oil Levels

- Check all oil levels once a week (engine oil, HP water pump oil, hydraulic oil).
- Add oil if necessary (*see page 34, Technical Specifications, Motor*).
- If oil level has dropped, this implies a leak in the system. In this case, check all gaskets, couplings, and hydraulic hoses in the system.
- Immediately repair damage and fill the system with the correct oil.



NOTE! During the break-in period, oil consumption may be greater than usual.

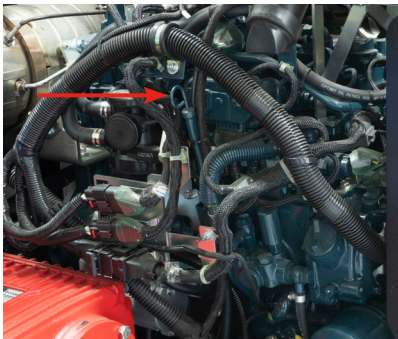

Engine Oil



Hydraulic Oil



HP Water Pump Oil

Clean the Water Filter

1. Unscrew the **water filter valve** (16) to close it.
2. Unscrew the cap from the **filter piece** (9).
3. Clean the filter and associated parts. After cleaning, assemble the parts in reverse order.
4. Open the **water filter valve** (16) by twisting it back in.
5. Check for leakage.



MINOR SERVICE

Minor service must be carried out **every 250 working hours** (or at least once every 6 months) and includes the following parts of the machine:

1. Drive and Engine

- Change the oil in the engine.
- Replace the oil filter.
- Clean the air filter.
- Replace the fuel filter.
- Check tension of the V-belt and increase tension if necessary.
- Check the condition of the battery.
- Check the torque of attachment bolts for the engine and tighten as necessary.

2. Carriage

- Lubricate all mechanical moving parts in the system. Check that all nuts and bolts have been correctly tightened.

3. Pump system

a. Cleaning the high-pressure control system:

- With the manual high-pressure valve closed, the pressure gauge should NOT indicate any pressure due to recirculation through the unloader valve.
- If the spray gun is connected and closed, the pressure gauge should NOT indicate any pressure due to recirculation through the unloader valve.
- If the pressure gauge does indicate a pressure, this implies a leakage in the system or the pop-off valve on the unloader valve may be dirty or damaged. (Contact Spartan Tool Customer Service for assistance.)
- If leakage is suspected, stop the machine, unscrew the hose coupling and clean or replace the pop-off valve on the unloader. Also, check the condition of the O-ring and gasket. (Contact Spartan Tool Customer Service for assistance.)

b. Regularly clean the high-pressure control system:

- Carefully remove all dirt.
- Proper maintenance will increase the service life of this part.

c. Changing the pump oil:

- Change the pump oil in the high-pressure pump after every 500 working hours (or at least once a year).

HYDRAULIC SYSTEM



IMPORTANT! Renew the hydraulic oil at least once a year!

1. Replace the hydraulic fluid in the reel drive system.
2. Check hydraulic oil level before each use. If level is not sufficient proceed as follows:
 - a. Stop the machine.
 - b. Ensure the unit is on a level surface.
 - c. Remove the dipstick (A) from the oil tank (B).
 - d. Clean the dipstick with a lint-free rag.
 - e. Put the dipstick back into the oil tank.
 - f. Remove the dipstick and check the oil on the dipstick is between maximum and minimum (C).
 - g. Fill oil, if necessary.
 - h. Return and tighten the dipstick to the oil tank.

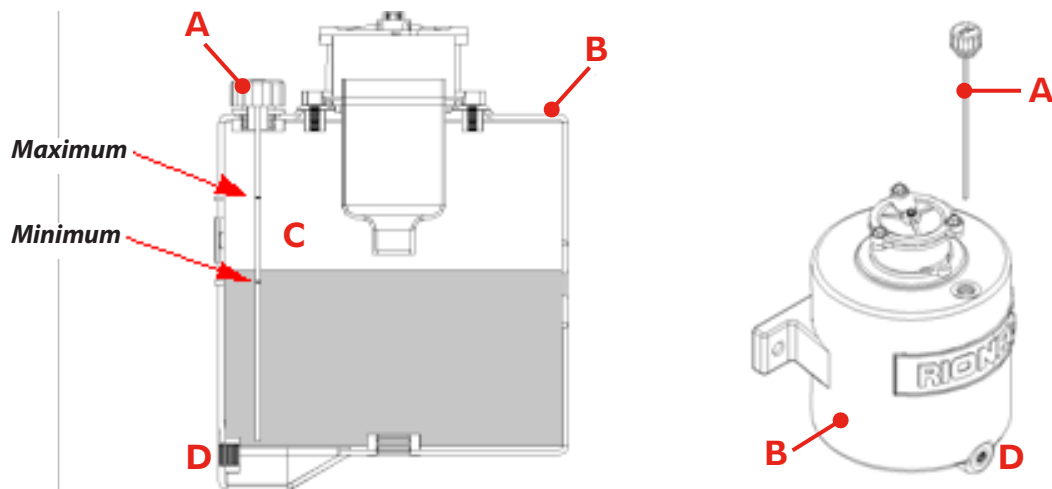

To let the oil out of the reservoir, unscrew the drain plug (D) and catch the oil in a drain pan.

ENGINE CONTROL MODULE

If the Engine Control Module indicates **Regen Needed**, proceed as follows:

1. Turn the Neutral Parking switch to **Parking**.
2. Select **Y** on the Engine Control Unit (see page 38 for more information).

(See page 42, Appendix A, *Engine Control Module* for more information.)

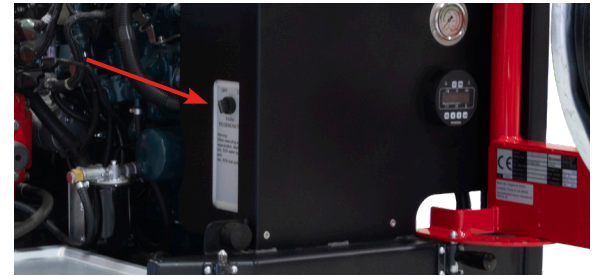

EXTENSIVE PERIODIC MAINTENANCE

Have the high-pressure machine checked and maintained on a regular basis by a Spartan Tool technician.

MAINTENANCE SCHEDULE

Check oil levels	Before each use
Clean water filter	Before each use
Clean carriage	Weekly
Service engine	Every 250 working hours or at least once every 6 months
Lubricate moving parts	Every 250 working hours or at least once every 6 months
Clean pressure regulator	Every 250 working hours or at least once every 6 months
Renew pump oil	Every 500 working hours or once a year
Renew oil hydraulic system	Once a year
Decalcify suction valves	Once a year
Decalcify pressure valves	Once a year
Puncture nozzle holes	Before each use
Replace parts immediately if there is wear or defect.	



Technical Specifications

GENERAL SPECIFICATIONS

Description	Unit
Dimensions	See page 41, Appendix B: Ultimate Urban Warrior Dimensions
Water tank capacity	~80 gal. per tank
Fill medium	Water (H2O) maximum
Temperature medium	132° F
Total length of high-pressure hose	~520 ft.
Diameter of high-pressure hose	½" (NW13)
Total length of supply hose	115 ft.
Diameter of supply hose	¾" (NW19)
Hydraulic oil type	Hestia 46 (Replace once a year)
Hydraulic oil tank capacity	5 liters
Maximum hydraulic temperature	80° C
Pressure regulator	ULH 262-2H
Year of construction	See name plate on frame

MOTOR

Description	Unit
Type	Kubota V2403-CR-TE4B
Number of cylinders	4
Power	48.6 kW (65 HP)
Fuel	Ultra low sulfur diesel (ULSD)
Fuel tank	~8 gal.
Cooling	Water cooled via heat exchanger
Weight	515 lbs.
Battery	12V 90AH 720A
Engine oil	API/SF-CC or better
Engine oil capacity	2.5 gal.

Normal coolant—engine is protected to -18° F.

Special coolant—engine is protected to -36° F.

PUMP

Description	Unit
Type	Speck P55
Maximum pressure	See name plate on frame
Maximum output	See name plate on frame
Weight	175 lbs.
Maximum water temperature	60° C / 140° F
Gear oil	GX 80W90
Gear oil capacity	1.2 gal.



Troubleshooting

FAILURE	REASON	SOLUTION
Engine does not start or stops abruptly.	Machine has run out of fuel.	Add fuel.
	Main or secondary fuse blown.	Replace the defective fuse and restart engine. If problem repeats, contact Spartan Tool Customer Service.
	Battery voltage too low.	Charge or replace the battery.
	Emergency stop activated.	Rotate the emergency stop button in order to be able to start up again.
	Insufficient level in the water tank (for cooling system).	Fill the water tank and let the machine cool down. When cooled, the machine can be started again.
	Engine coolant level low.	Fill the cooling system at the expansion tank.
	Temperature of engine coolant too high.	Let the machine cool down.
The high-pressure pump does not produce the required pressure.	Water tank empty.	Fill the water tank.
	Supply valve to water filter closed.	Open the supply valve.
	Water filter clogged.	Stop the machine and clean the water filter.
	Air in the high-pressure pump.	Allow the machine to run a few minutes. The failure will normally disappear. If not, contact Spartan Tool Customer Service.
	Suction valves blocked.	Carefully loosen the valves and de-scale them, if necessary.
	V-belt not sufficiently tightened.	Tighten the V-belt; replace if necessary.
	Suction valves worn out.	Contact Spartan Tool Customer Service.
Pressure varies.	Water level in tank too low.	Stop the engine, refill the tank and restart engine.
	Water supply valve not sufficiently opened.	Open the supply valve completely.
	Water filter clogged.	Stop the machine and clean the filter.
	Pump sucks air.	Stop the machine and check all hoses and couplings for leakage.
	Nozzle clogged.	Stop the machine and clean the nozzle (clean the nozzle holes).
	Pressure valves dirty or worn.	Stop the machine. Check the condition of the pressure valves. Clean or replace them.
	Pump gasket worn out.	Stop the machine and replace gasket.
	Pump v-belts slip.	Stop the machine and tighten the belts.
	Ceramic plungers in the pump damaged.	Contact Spartan Tool Customer Service.
	Pressure control clogged or internally damaged.	Contact Spartan Tool Customer Service.

FAILURE	REASON	SOLUTION
Hydraulic reel does not wind the hose.	Handle in wrong position.	Put the handle into the correct position.
	Hydraulic tank almost empty.	Refill the tank. Check the system for leakage.
	Attachment bolt for control lever of hydraulic system is loose.	Fasten the bolt and put the lever into the correct position.
	Working pressure set too low.	Increase the working pressure, if possible.
	Hydraulic tank return filter dirty.	Switch off the machine and clean the return filter.
	Hydraulic system damaged.	Contact Spartan Tool Customer Service.
No reaction from the Riomote controller.	No current.	Recharge the battery.
		Use new battery.
		Contact points are dirty.
		Check fuses.
	Contact Spartan Tool Customer Service if problem is frequent or ongoing.	
	Transmitter is not on.	Activate the transmitter (link to the receiver).
Transmitter out of reach from receiver.	Put the machines closer together. Move transmitter closer.	
Warning signal after short working time.	Battery discharged / defective.	Charge or replace the Riomote® battery.
		Check the terminal connections.
Transmitter indications are good but functions are not executed.	Emergency stop pushed in.	Unlock emergency stop.
	Receiver has no current.	Check / replace fuses.
	No radio connection.	Check functions of control lights.
Certain functions are not executed.	Receiver is faulty.	Contact Spartan Tool Customer Service.
	Interruption in electric current.	Check all plugs. Plug in and push. Check control lights if functions are indicated.



APPENDIX A

Engine Control Module

The Engine Control Module (ECM) consists of two major functions.

The function of the Engine Safety Protection Panel is to **monitor engine parameters** to alert the operator to any abnormal conditions requiring attention as well as any operating limits that may be exceeded requiring the machine to be immediately shut down. Once the engine is started, the ECM has primary control of the engine providing prealarms, alarms and safety shutdowns.

This attachment provides the operator with information necessary to understand the operation of the Engine Safety Precautions Panel.

The diagram below identifies the indications available on the Engine Safety Protection Panel which will be explained on the subsequent pages.

INDICATOR LAMPS AND ENGINE CONTROL UNIT INDICATIONS

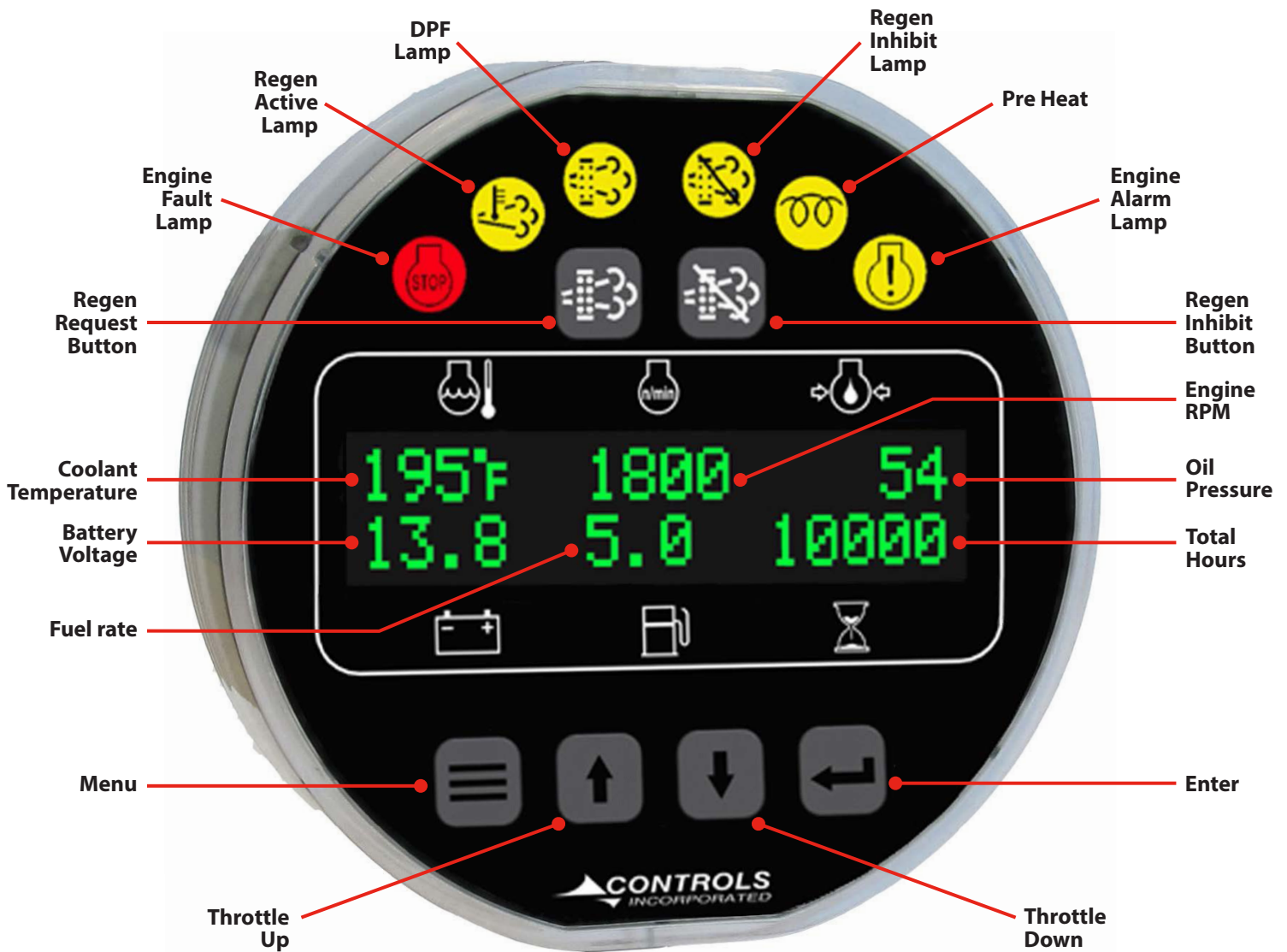

EMISSIONS MONITORING AND REGENERATION

Part of the ECU continuously monitors the engine's emissions parameters. The build up of soot and ash in the engine can reduce power and may cause the engine to stall. To avoid this condition, the ECU will alert the operator when regeneration is required to remove built-up deposits in the engine.

Regeneration Levels

Level 0 (Passive)	Normal engine operation. Removal of soot and ash is accomplished by current engine speed and load.
Level 1 (Auto)	The ECU enables automatic regeneration. There is no effect on engine performance or operation during automatic regeneration. At this point Disable Inhibit can be activated by a Yes/No prompt. If inhibited, Regen Needed will continue to scroll down on the LCD display.
Level 2 (Auto/Parked)	As soot and ash level increase, the ECU may continue as in Level 1, or may send a Parked Regen request to the DFP display.
Level 3 (Parked)	The ECU will send prompts to the controller and light the DPF lamp.
Level 4 (Service Regen)	The Regen Needed prompt will appear. At this stage, a service technician is required to perform regen.
Level 5 (Service Required)	The engine requires service by an authorized dealer.

ECU Module Regen Buttons DPF Lamp

When a regeneration is required, the ECU sends a signal to light the DPF Lamp. The lamp will remain lit until a regen has been completed.

Regen Inhibit

Pressing this button for at least 2 seconds will alternate the module between the Regen Inhibit and Regen Auto modes. Any time the ECU indicates a regeneration is required, a prompt will appear asking the operator if they want to switch to the auto mode.

Regen Request

This button will function when a required regen has been announced by the ECU and subsequently denied by the operator. If the operator wants to reinstitute the regeneration prompt, they can push the button for at least 2 seconds.

Regeneration Process

Every two minutes when a regen is required, the **Regen Needed** prompt will appear on the ECU display. To proceed with the regen, press the **Enter button** for yes.



APPENDIX A

Engine Control Module



Parked Regen
Needed

If the operator selects No, the **Parked Regen Needed** display will continue to flash on the ECU display.



RPM Max Increase
N=Menu Y=Enter

If the operator selects Yes, the controller will alert the operator that the engine RPM may increase. The operator should press **Enter** to acknowledge.



Set Min Speed
N=Menu Y=Enter

The next prompt alerts the operator that the regeneration requires the engine be set to the minimum idle speed. The operator should press **Enter** to acknowledge the process.



Min: 800 Spd: 800
N=MENU Y=ENTER

The next screen is the acknowledgment of the actual speed as set by the ECU. Use the down arrow to lower the speed. Once the speed is matched, press the **Enter** button.



Apply Park Brake
N=MENU Y=ENTER

To ensure the engine load is removed during regeneration, the parking brake and neutral switch are applied. **It is not acceptable to initiate parked regeneration when engine load is applied.**



Put in Neutral
N=Menu Y=Enter

The operator places the switch to **Parking** and acknowledges by pressing **Enter**, then places the switch in **Neutral** and acknowledges by pressing **Enter**.



Begin Regen
N=Menu Y=Enter

After the operator has acknowledged the prompt screens, the regen request will be sent to the engine ECU and the full regeneration process will be activated.



Regen Prog 1%
[-----]

During the regeneration process, the progress can be monitored on the ECU display. The display will indicate a maximum of 10% until the engine achieves the desired temperature to remove ash and soot.



Regen Complete
OK=Enter

At the end of the process, the controller will prompt the operator that the regeneration is complete. The operator must acknowledge by pressing the **Enter** button prior to resuming normal operation.



Park Brake Fail
OK=Enter

The regen process will be aborted if the **neutral parking switch** is opened during the process. When this occurs, a message will appear requiring the operator to acknowledge. There may be other causes for a regen to fail. If this occurs, a message will be displayed indicating **Regen Failed** or **Regen Aborted**.



Not In Neutral
OK=Enter

APPENDIX B Machine Dimensions

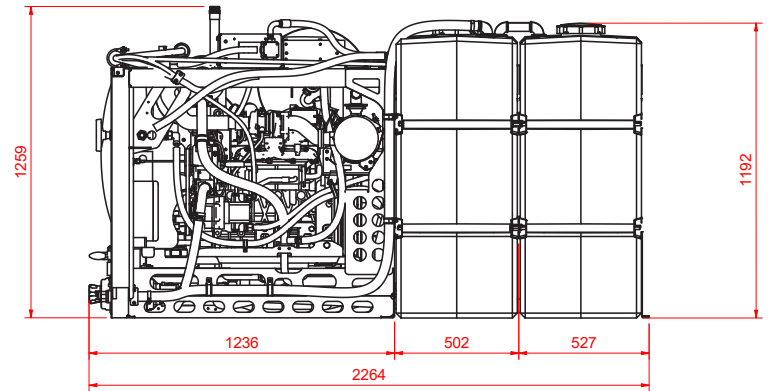
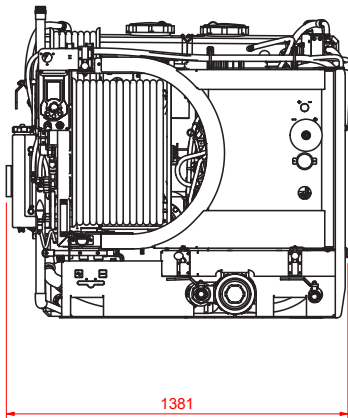
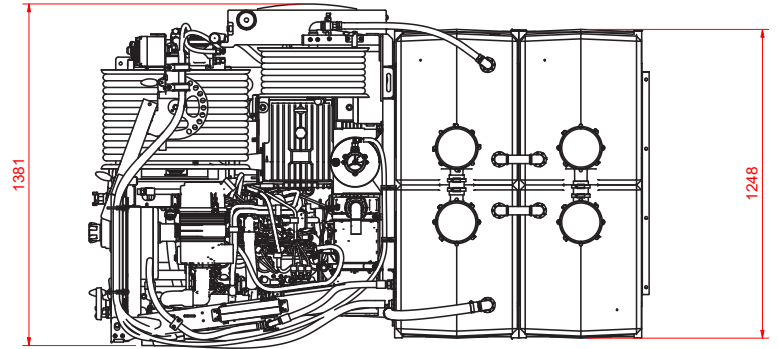
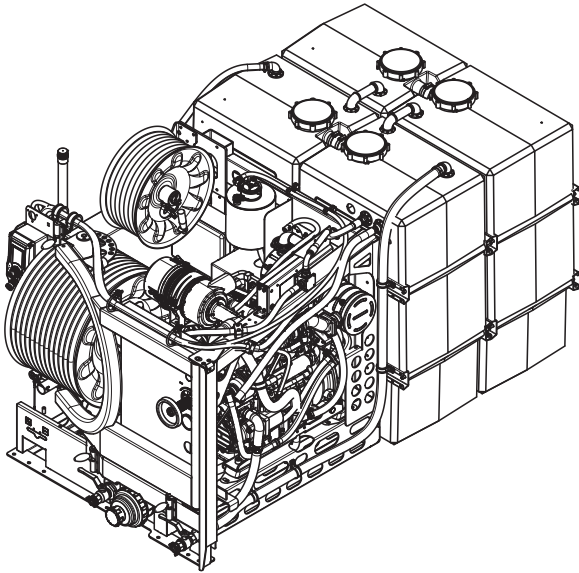



SPARTAN

FOR TOUGH CUSTOMERS.

SINCE 1943

CONTACT US

Spartan Tool LLC

1506 West Division Street

Mendota, IL 61342

800.435.3866

SpartanTool.com