



SPARTAN

MODEL 300

Owner's Manual

Record the Serial Number of your
Model 300
and give the number to the factory when
ordering parts.

Serial
Number _____



Spartan Tool L.L.C.

800.435.3866

www.spartantool.com



— Read the safety and operating instructions before using any Spartan Tool products. Drain and sewer cleaning can be dangerous if proper procedures are not followed and appropriate safety gear is not utilized.

— Before starting unit, be sure to wear personal protective equipment such as safety goggles or face shield and protective clothing such as gloves, coveralls or raincoat, rubber boots with metatarsal guards, and hearing protection.

— Drains and sewer can carry bacteria and other infectious micro-organisms or materials which can cause death or severe illness. Avoid exposing eyes, nose, mouth, ears, hands and cuts and abrasions to waste water or other potentially infectious materials during drain and sewer cleaning operations. To further help protect against exposure to infectious materials, wash hands, arms and other areas of the body, as needed, with hot, soapy water and, if necessary, flush mucous membranes with water. Also, disinfect potentially contaminated equipment by washing such surfaces with a hot soapy wash using a strong detergent.

— For any questions contact the company at the address shown below.

“California Prop. 65: This product may contain an extremely small amount of lead in the coating. Lead is a material known to the State of California to cause cancer or reproductive toxicity.”

SPARTAN TOOL L.L.C.
1506 W. Division Street
Mendota, IL 61342
800.435.3866 ♦ Fax 888.876.2371
www.spartantool.com



Table of Contents



OPERATING SECTION

Introduction	4
Service Information	4
Specifications and Features	5
Safety Instructions	6-9
Machine Features	10
Assembly Instructions	10-13
Operating	14-16
Operating the Power Cable Feed	16
Special Applications Procedure	17
Maintenance Instructions	18-21

PARTS SECTION

Model 300 (110 volt & 20 volt)	22
Frame Assy - 04217000	23
Model 300 Drum Unit-44129300	24
Wiring Diagram	25
Air Foot Switch-44055500	25
PM Motor Assembly (110 volt & 220 volt) --	26
5/8" Cable	27
.55 Magnum Cable	28
Old Style Motor to PM Motor Conversion --	29
Optional Compact Lift-02884900	29
Optional Model 100 Drum Adapters	30
Tool Box and Accessory Kit	31
Pneumatic Tire Upgrade Kit-44250700 ----	32
300 Hoist Bracket- 44295810	32
Spartan Accessory Blades	33

POWER CABLE FEED SECTION

Introduction	36
Attaching the Cable Safety Guide	37
Setting Your Cable Size	38
04221000 Universal Power Feed	39
44224200 Model 2001 Power Feed	40
04217500 Power Feed Assembly	41
04224000 Bearing Block Assy (Long)	42
44219900 Bearing Block Assy (Short)	43
44119600 Wheel Carrier Body (Long)	44
44119700 Wheel Carrier Body (Short)	44
Model 1065 & 2001 Installation	45
Model 200 and 300 Installation	46
Model 100 Installation	47
Operating Instructions	48
Cleaning Operation	49
Disassemble & Reassemble Power Feed	49
Disassembly of Short Bearing Blocks	50
Disassembly of Long Bearing Blocks	51
Cleaning & Lubricating Instructions	52
Re-Assembly of Short Bearing Blocks	52
Re-Assembly of Long Bearing Blocks	53
Cable Safety Guide	54-55

GENERAL INFORMATION SECTION

Warranty Information	61
----------------------------	----



Introduction



The Spartan Model 300 Electric Drain/Sewer Cleaning Machine has been designed and manufactured with high quality materials and care in workmanship. The instructions in this manual have been prepared to ensure that, when followed, the Spartan Model 300 will provide long and efficient service.



WARNING: It is the responsibility of the operator to read and understand the Operator's Manual and other information provided and use the correct operating procedure. Machines should be operated only by qualified operators. Failure to do so can result in personal injury, death or machine damage.

Read the entire manual before the initial start-up of the machine. It is important to know the correct operating procedures of the machine and all safety precautions to prevent the possibility of property damage and/or personal injury.

NOTE: Information in this manual is current at the time of printing. Spartan Tool reserves the right to make changes and improvements to its products at any time without notice or obligation.



Service Information



All requests for information, service or parts should include machine serial number. Additional copies of this Owner's Manual can be downloaded free of charge from the Spartan Tool website, www.spartantool.com.

For more information contact: Customer Service, Spartan Tool L.L.C.
1506 W. Division Street
Mendota, IL 61342-2234
Phone (800) 435-3866
Fax (888) 876-2371

Record below and retain product model and serial number.

Model Number: _____

Serial Number: _____

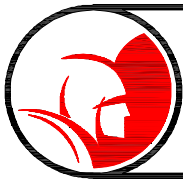

Specifications and Features



Drum Capacity: 75' of 5/8" cable or 100' of .55 magnum cable.

Cleaning Capacity: up to 250' (recommended line size: 3" - 6" diameter)

Motor: Permanent magnet; 115 volt AC (rectified); 1.25 amps (DC) @ 300 rpm (no load); 4.6 amps (DC) 155 in-lb torque @ 160 rpm.

Weight: 101 lbs. for a 300 Dial-A-Cable machine w/5' anchor cable.

Height: 30" to top of handle (retracted)
41" to top of handle (extended)

Width: 18"

Length: 29" with Dial-A-Cable Power Feed

Drum Speed: 300 RPM with no load.

Cable Feed: Spartan Dial-A-Cable Power Cable Feed.

Frame: Extra strength aluminum/magnesium alloy.

- Heavy duty permanent magnet motor with reverse capability.
- Inner drum rotates independently of outer drum, virtually eliminates cable kinking, buckling and controls torque buildup.
- Outer drum keeps dirt inside, off operator and work area.
- Air foot switch with cord assembly keeps both hands free for safe, easy operation.
- Compact, portable design.
- Extra-strength aluminum magnesium alloy construction.
- Integral continuous belt stair skids.
- Retractable "Sure-Grip" extending handle.

IMPORTANT

For your own safety

Before assembling and operating this unit, read this operator's manual carefully and completely. Learn the operation, applications and potential hazards peculiar to this unit.

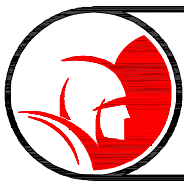

Safety Instructions



Use of any electrical equipment in a wet or damp environment can cause fatal shock if not properly guarded against by the operator.

1. Know Your Drain Cleaning Machine. Read this Operator's Manual carefully. Learn the operation, applications and limitations of this machine.
2. Grounding Instructions. Before using your Spartan equipment, make sure that a properly grounded, (three hole) electrical outlet is available. If not, as in older homes, use a three-prong adapter and connect the green pigtail or grounding lug to a known ground, such as a (metallic) cold water pipe.

This tool should be grounded while in use to protect the operator from electric shock. The tool is equipped with a three-conductor cored and proper grounding type receptacle. The green (or green and yellow) conductor in the cord is the grounding wire. Never connect this wire to a live terminal. Units designed for use on less than 150 volts, have a plug that looks like that shown in Fig. 1A. An adapter, (Fig. 1B and 1C), is available for connecting three-prong plugs to two-prong receptacles, (except in Canada). If such an adapter is used, the green colored rigid ear, lug, or the like, extending from the adapter must be connected to a permanent ground such as a properly grounded outlet box.

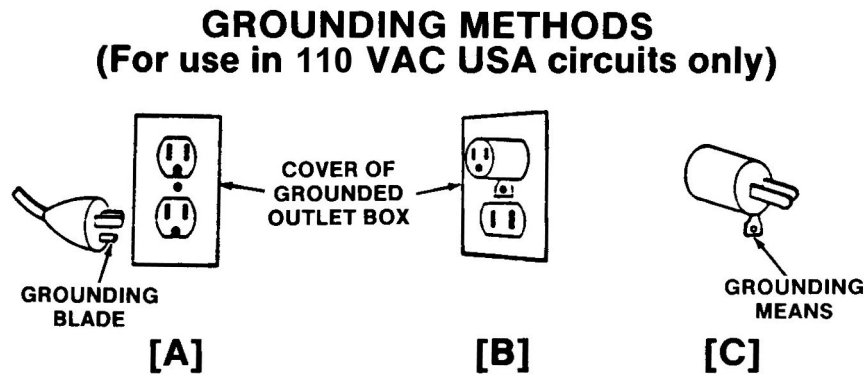
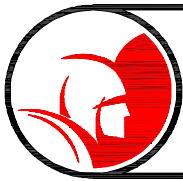

Figure 1

This machine is equipped with a Ground Fault Circuit Interrupter (GFCI), which should always be plugged directly into an inspected, grounded receptacle. Plug the three-pronged plug on the machine power cored with GFCI directly into an inspected grounded outlet and then test and reset the GFCI.

Never cut off the grounding prong on the power cord for use in a two-hole outlet. Doing so cuts off your protection from shock. Replace or repair all damaged power cords and components.



Safety Instructions (cont.)



3. Extension Cords. DANGER- Improper use of an extension cord will cause death or severe injury. The GFCI on the machine's power cord does not protect the operator from electrical shock along the extension cord.

If an extension cord must be used, it must be of an approved, three-wire construction, equipped with a three-pronged plug, and in good condition. Replace or repair damaged cords.

Do not use an undersized extension cord. An undersized cord will cause a drop in line voltage resulting in loss of power and overheating. Use the following minimum gages depending upon the length of the extension cord:

-16 Ga. –for cords of less than 100 feet in length

-14 Ga. –for cords of 100 feet to 150 feet in length.

If in doubt, use the next heavier gage. (The smaller the gage number, the heavier the cord.) When the machine is used outdoors, use only extension cords intended for use outdoors and so marked. Do not allow an extension cord to be exposed to water.

Don't assume that all three hole outlets are properly installed. Check the outlet and also the adapter, if used, with an outlet testing device which quickly indicates if a ground is connected. Correct a faulty test indication before proceeding.

4. Don't Abuse Cord. Never move or lift tool by cord or yank it to disconnect from receptacle. Keep cord from heat, oil and sharp edges.
5. Disconnect Power Cord. When not in use, before servicing, and when changing accessories, such as blades and cutters.
6. Guard Against Electric Shock. Prevent body contact with grounded surfaces such as pipes, radiators, ranges, refrigerator enclosures.
7. Avoid Accidental Starting. Don't move plugged-in tools. Make sure switch is in OFF position before plugging in power cord.
8. Stay Alert. Watch what you are doing. Use common sense. Do not operate tool when you are tired.
9. Keep Work Area Clean. Cluttered areas invite injuries.
10. Consider Work Area Environment. Don't expose power tools to rain. Keep work area well lit.

Do not use tool in presence of flammable liquids or gases.

Avoid operating the machine in areas of standing water.



Safety Instructions (cont.)



11. Dress properly. Do not wear loose clothing or jewelry. They can be caught in moving parts. Wear protective hair covering to contain long hair.

Wear standard equipment. (Spartan riveted gloves). Never grasp a rotating cable with a cloth or loose fitting glove which would get wrapped around cable. Replace gloves if rivets or staples start to pull out.

Wear rubber boots and wear rubber gloves inside your Spartan cable handling gloves to further insulate yourself.

12. Use Safety Glasses. Guard against foreign material that might fly off cable.

13. Don't Overreach. Keep proper footing and balance at all times.

14. Keep Children Away. Do not let visitors contact tool or extension cord.

All visitors should be kept away from work area.

15. Use Recommended Equipment and Accessories.

Use of improper equipment may be hazardous.

Don't force small cable with attachment to do the job of heavy-duty cable.

16. Don't Force Tool.

It will do the job better and safer at the rate for which it was intended.

17. Remove Punches and Wrenches. Form a habit of checking to see that punches and adjusting wrenches are removed from tool before turning it on.

18. Keep Guards in Place. Never operate machine with guard removed.

19. Avoid Operating Machine in Reverse. Operating machine in reverse can result in cable damage and is used only to back tool away from an obstruction.

Warning! Continued drum rotation in reverse position will cause cable to "jump" out of drum. Possible operator injury could result.

20. Do Not Over Torque Cables. Excessive and/or continued rotation of the drum once an obstruction has been encountered will over torque the cable. Kinking or breakage of cable may result. A worn cable can be identified as being very limber, kinked or as having flattened coils on the outside of cable. Worn cable should be replaced as soon as possible.



Safety Instructions (cont.)



21. Maintain Tools with Care. Keep tools sharp and clean for better and safer performance.

Follow instructions for lubricating and changing accessories.

Never use damaged power cords.

Inspect tool cords periodically and if damaged, repair with proper Spartan replacement parts.

Inspect extension cords periodically and replace if damaged.

Keep handles dry, clean, and free from oil and grease.

22. Check Damaged Parts. Before further use of the tool, a guard or other part that is damaged should be carefully checked to determine that it will operate properly and perform its intended function. Check for alignment of moving parts, binding of moving parts, breakage of parts, mounting and any other conditions that may affect its operation. A guard or other part that is damaged should be properly repaired or replaced.

Replace defective switches with proper Spartan replacement parts.

Do not use tool if switch does not turn on and off.

23. Store Idle Tools. When not in use, tools should be stored in a dry and locked up place, away from children.

24. Handling Cables. Be very careful when cleaning drains exposed to cleaning compounds. Wear protective gloves when handling cable, and avoid direct contact of skin and especially the eyes and facial areas as serious burns can result from some drain cleaning compounds.



Machine Features



300 With Dial-A-Cable Power Cable Feed

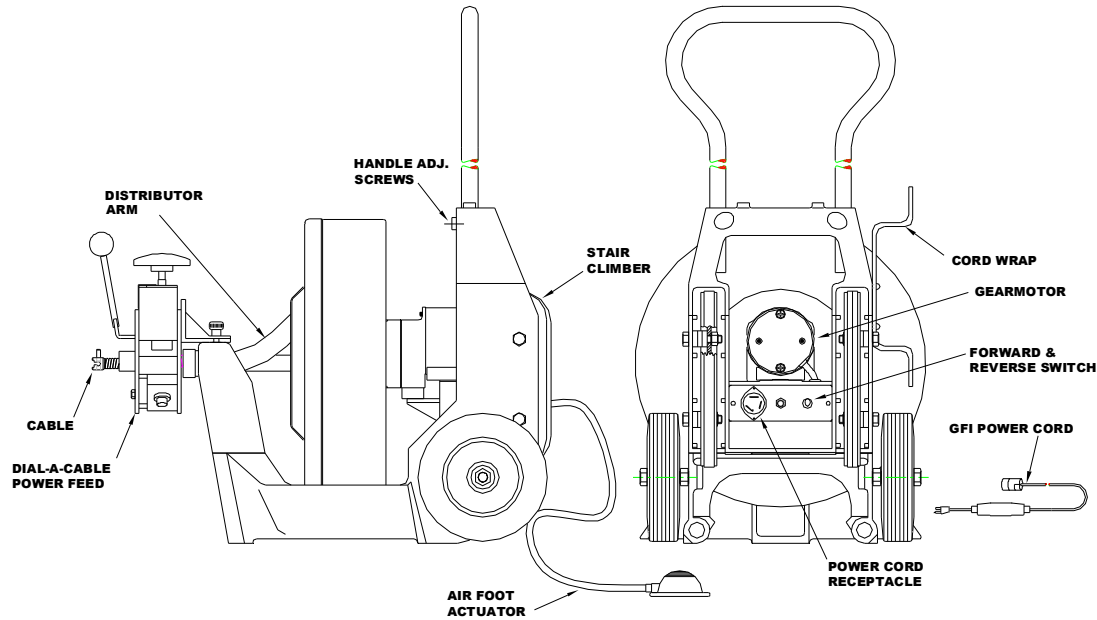

Figure 2



Assembly Instructions



STUDY THESE INSTRUCTIONS CAREFULLY BEFORE YOU OPERATE YOUR EQUIPMENT

JOINING CABLES

All cables and leaders are coupled together by male and female couplings, and held securely by means of expansion pins as illustrated.

The cable and coupling stand is furnished with the optional tool box to provide a support on which to rest your cable when assembling or disassembling the couplings.

Assembly:

Place coupling in groove on top of stand with portion of expansion pin in upright position. Using hammer, drive expansion pin down flush with coupling. Assembly is complete, cable and machine are ready for use.



Assembly Instructions (cont.)



Disassembling:

Position coupling stand at convenient distance from machine (2-3 feet.) Place coupling in groove, expansion pin up, on top of stand. Place tip of punch (provided with machine) in expansion pin. Drive expansion pin down with hammer. Note the shoulder on tip of punch, acts as a stop. Drive the punch until shoulder is flush with the coupling. This is sufficient to permit the male and female portions of the coupling to be separated but leaves the expansion pin, held securely in one half of the female coupling, in ready position for reassembly.

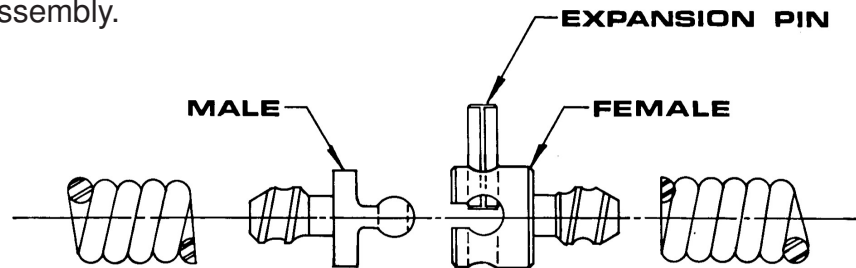

Figure 3

LOADING CABLE INTO MACHINE

Warning: Due to the amount of initial tension wound into your Spartan cable, care must be taken when uncoiling the bundle of cable. The cable will spring apart after the wire ties, which secure the cable, are cut.

After uncoiling the cable and laying out flat, attach the male end of the cable to the female end of the 10' anchor in the drum. With the machine plugged in, depress the foot actuator and check the rotation of the drum. The drum should rotate in a counter-clockwise direction, as you face the front of the machine. If the drum rotates in the wrong direction, reverse the toggle switch located (Ref. to Figure 2) on the motor support and check rotation again. With the drum rotating in the proper direction, start feeding the cable into the drum.

Caution: Always wear your riveted Spartan gloves when handling a rotating cable. Read the section "How to Operate the Power Cable Feed" before you begin to feed cable into the drum.

Feed the cable into the drum with the drum rotating. This insures proper distribution of cable inside the drum.

Leave about 2-3 feet of cable out of the machine to allow for attaching the next section of cable. After loading your desired length of cable, attach either a two foot leader cable or a double male coupling. You are now ready to attach your Spartan cutter blade assembly. (See Figures 4 & 5 for Cable Connection Diagram).

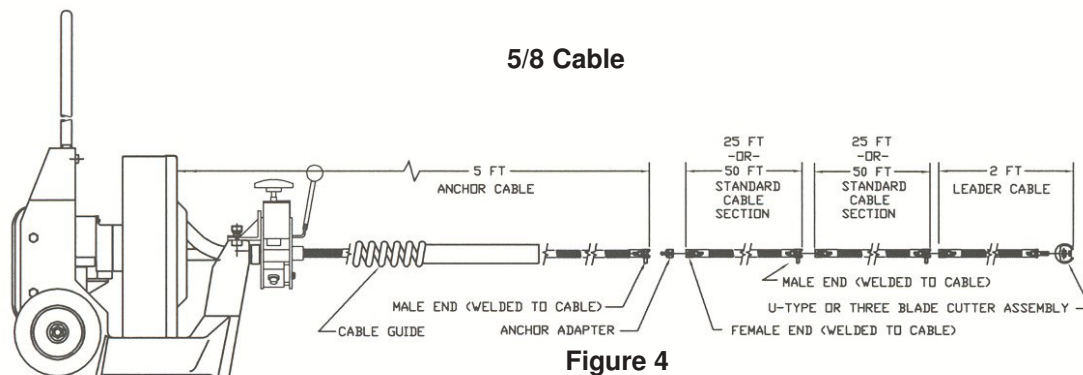

Figure 4



Assembly Instructions (cont.)

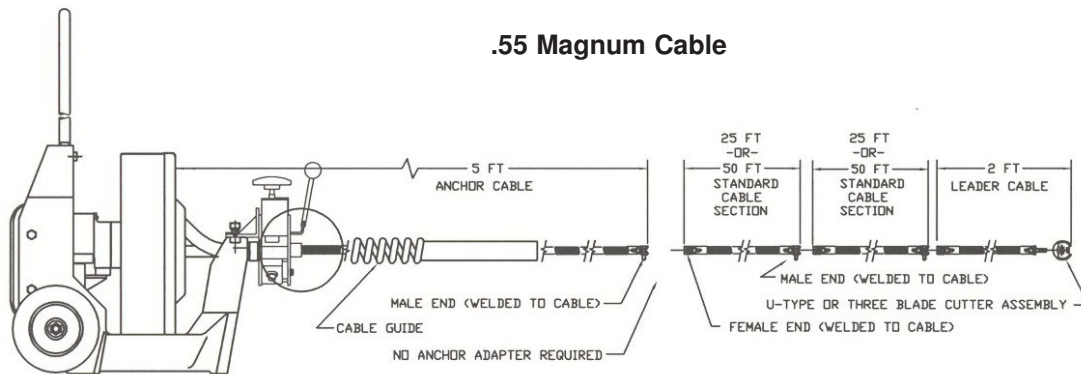

Figure 5

ASSEMBLY OF BLADES TO CABLE

WARNING: Always disconnect power cord before attaching or changing blades.

Each U-Type Cutting Assembly consists of:

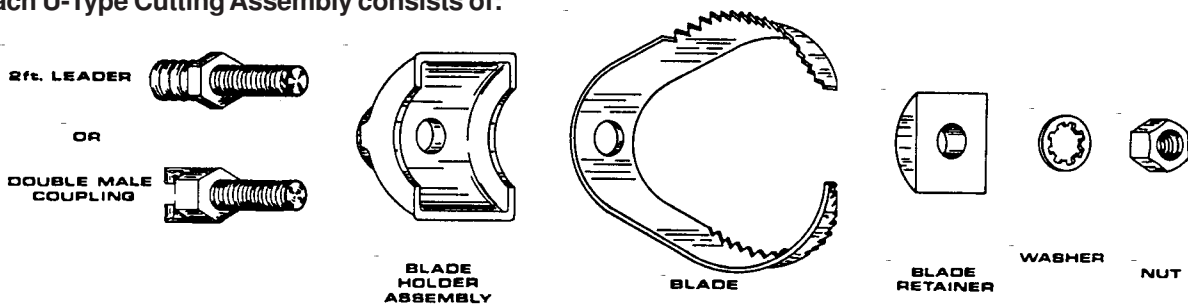

Figure 6

Each Three-Blade Cutting Assembly consists of:

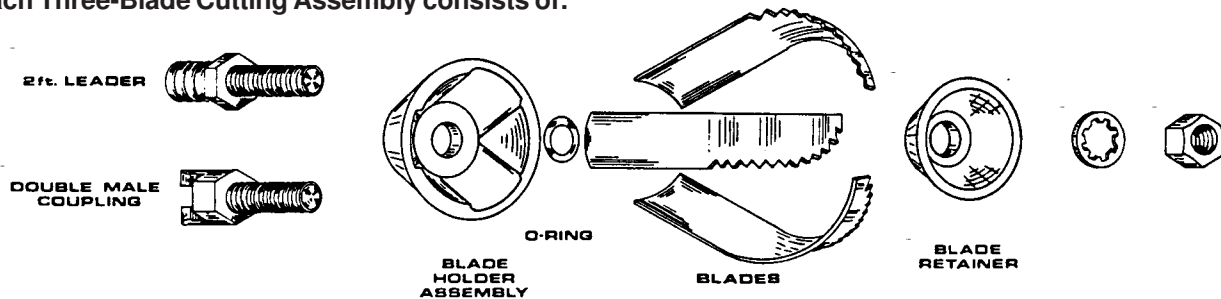
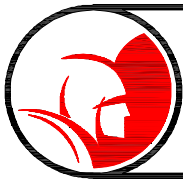

Figure 7

BLADES- The optional tool box is furnished with a number of different sizes and shapes of blades for various size sewers and types of cleaning work. (Additional tools are listed on page 13)

Your Spartan blades can be attached to either a 2' leader cable or a double male coupling. To attach a cutter assembly the base of the blade holder assembly needs to be seated onto the hex part of the leader or double male coupling. Next, the proper blade size is placed into the blade holder base. After inserting the blade, secure with blade retainer, lock washer and nut. **Draw up all blades assemblies tightly** with your T-wrench, otherwise vibrating may cause unnecessary loss of blades. A T-wrench is furnished so you can quickly and conveniently assemble blades. With the blade assembly attached, your now ready to operate your Spartan machine.



Assembly Instructions (cont.)



OPTIONAL TOOLS

Part #	Description	Use
44006700	Extra Heavy Razor Sharp 2-1/2" Round Cutter Blade	Used to cut roots and clear blockages in 3", 4" and 6" lines. High wear resistance.
44052600	Boring Tool	Used in 3", 4" and 6" lines for penetrating major blockages.
03416600	3" Grease Blade	For cleaning grease or muck lines. Integral "paddles" act as a scoop and cause a churning action within the line for quicker, more efficient cleaning.
03416700	4" Grease Blade	For cleaning grease or muck lines. Integral "paddles" act as a scoop and cause a churning action within the line for quicker, more efficient cleaning.

OPTIONAL ACCESSORIES

Tool box and the following accessories:

- cable uncoupling stand
- punch for expansion pin
- "T" wrench
- 3" and 3-1/2" "P" trap blades with blade holder assembly
- spear blade
- 2" and 2-1/2" blades with blade holder assembly
- 3", 4" blades with blade holder assembly
- retriever
- riveted gloves
- expansion pins, double male, male and female couplings, splicer
- 2' flexible leader

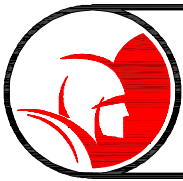

Operating



WARNING: Never wear loose fitting clothing or jewelry when operating this machine. **Always** wear your Spartan riveted gloves when handling cable.

1. Couple the leader or double male coupling, complete with the proper tool, onto working end of the cable. See assembly instructions.
2. Use a small blade or spear blade on the end of your cable first. Most lateral lines are 4" to 6" in diameter. It is advisable to use a 3" blade or spear blade first. That enables you to cut the core out of the obstruction, to get the water running. Then remove the 3" blade, or spear blade. Put on a blade the size of the sewer line to be cleaned, so you can actually scrape the line - thereby giving a thorough, efficient cleaning job

A good rule of thumb is to use a tool at least 1" smaller than the line to be cleaned. The style of tool is determined by the nature of job and is left to the discretion of the operator.

Flexible trap leaders should be used to negotiate p-traps and severe bends in line.

Double male couplings should be used when operating in heavy root build up or severe obstructions.

3. Place your machine as close to the cleanout as possible. **Do not allow more than 4 feet of cable between the machine and the cleanout. Always use the Cable Safety Guide.**

WARNING: Operator should be thoroughly familiar with the Safety Instructions Section before attempting to operate this equipment.

4. Place foot switch, in a comfortable and accessible position in order to have power at all times.
5. Place the switch in the "F" (forward) position. Check by pressing down on footswitch making sure that drum rotates in counter clockwise direction as you face the drum.
 - 5a. Hand-feed the tool into the opening of the line and feed about 6" of cable in before turning machine on.

Refer to the section "How to Operate the Power Cable Feed" before proceeding.

6. Exert sufficient downward pressure on the Cable Safety Guide to keep cable in line while depressing foot actuator to start cable rotating.
 - 6a. When using a Dial-A-Cable Power Cable Feed, keep one hand on the Cable Safety Guide halfway between the cleanout and the power feed outlet. Keep your other hand on the power feed control handle.
7. When your blade meets an obstruction, it will no doubt fail to rotate. A reduction in RPM will be noticed. If RPM of the motor and drum decrease, quickly pull back on the cable to disengage blade from the root or other obstructions. Thereby releasing torque or tension on your cable - preventing buckling or kinking of cable.

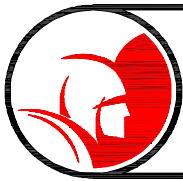

Operating (cont.)



WARNING: Do not permit blade end to get hung up in an obstruction for more than 2 to 3 seconds. Your job as an operator of this machine is to keep the cable rotating. Remember do not operate the machine to the point where the cable begins to buckle. This practice is dangerous and could damage the cable.

NOTE: Kinkage and breakage of cable is caused solely by one thing: you permit the working end of the cable to get hung up in an obstruction and you keep on twisting the other end of same with your motor, until something must give. Remember, the only way you can clean an obstruction from a line, or negotiate a bend in a line, is when your blades are rotating. Let us repeat -your job is to keep the blades rotating. The design of your motor is such that as soon as the blade end of your cable gets hung up in an obstruction, your motor RPM reduces. That reduction in speed is notice to the operator to pull the blade away from the obstruction, thereby releasing the tension that has been built up in the coil-spring cable. That release of tension prevents buckling, kinking or breakage of the cable.

8. A good rule to follow for releasing tension on a cable is this: when your blade gets hung up in the obstruction and fails to rotate, an RPM reduction will be noticeable which indicates it is time to pull the blade away from the obstruction. As you pull it away, all tension in the cable will be released immediately and your blades will turn at a high speed. As soon as the blade is free, push it back into the obstruction quickly so as to utilize the built-up power which enables you to clean the line more quickly and efficiently.

WARNING: Do not allow a tool to get hung up in an obstruction. If a tool gets hung up in an obstruction, a reverse feature is provided on this machine for just this purpose. In the event your blade gets hung up on an obstruction and you are unable to release it in the normal manner, move the toggle switch to the "OFF" position, and permit your machine to come to a dead stop. Then, move the toggle switch in the "R" (reverse) position. Now start your machine slowly. See if you can remove the blade from the root or other obstruction by this reverse action. When the blade is released, let your machine come to a dead stop again. Then place the toggle switch in the "F" (forward) position. Make sure that the cable/blade rotates counter clockwise, when standing in front of the machine, except when reversing it to free cutting tool from obstruction.

WARNING: Do not reverse machine until motor and drum come to a dead stop.

Avoid operating this machine in reverse for any other purpose.

9. When you cut through one group of roots, it is always good to pull back your cable and take another cut. This final cut is what gives you a thorough cleaning job.



Operating (cont.)



10. When the job is complete, feed the cable back into drum, making sure that your machine is running, so that the distributor arm can feed and distribute cable in the drum properly.

KEEP MACHINE RUNNING in the forward direction.

WARNING: Never retract tool from sewer inlet while cable is rotating.

NOTE: It is recommended that a continuous flush of water be used to clean cable and tool as they are retrieved.

11. When tool is close to the clean out opening, release foot actuator and allow machine to come to a complete stop.

12. Move toggle switch to the "OFF" position and disconnect machine from power source.

13. Pull remaining cable and tool from the line and hand-feed cable back into the drum.

Operating the Power Cable Feed

1. The adjusting knob on the top controls the tension on the cable. It should be set so that the cable feeds freely in-and-out of the drum. Tension can be increased by turning handle to the right. Don't apply too much tension - just enough to keep the cable moving is sufficient.
2. Cable is fed into the line by putting the handle in forward position. This speed will vary from 0-30 feet per minute depending on size of the cable and how far forward you push the handle.
3. Cable is brought out of the line by putting the handle in reverse position. You can also vary the speed in reverse.
4. When the handle is straight up, the drive is in neutral position. There is no lateral movement of cable at this point. This enables the operator to position the blade against the stoppage and chew it away if necessary.
5. Another feature of the Dial-A-Cable Power Cable Feed is its ability to change from FORWARD to REVERSE by simply moving the handle. The feed reacts immediately.
6. New drive design permits repair right in the field. Entire unit can be taken apart and put back in working order in just ten minutes.

WARNING: (1) **Never** try to force the cable in to the line. Choose a proper feeding speed that gives a smooth cutting action. (2) Refer to operating and maintenance instructions for proper maintenance.

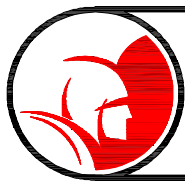

Special Applications Procedure



CLEANING LINES THROUGH A MANHOLE:

1. Position your machine at top and about 1' away from manhole.
2. Use a length of 1-1/2" pipe with 45° elbow screwed there to (the depth of the manhole determines the proper length of pipe to be used).
3. Hand-feed your cable, less leader and blade, through proper length of 1-1/2" pipe.
4. Fasten leader or double male coupling with proper size blade to end of cable.
5. Place blade into line by the use of extension pipe. The length of pipe referred to provides a guide for your flexible shaft from the top of the manhole to the entrance of the line, thereby preventing your cable from buckling or kinking. It likewise enables the operator to operate the machine in a convenient, comfortable position at the top of the manhole. **Never enter the manhole.**

RODDING FARTHER THAN 75' (5/8" CABLE*):

The object of the 5' anchor cable in the drum is this: When you have fed 75' of cable into the line, the female coupling on the end of the 5' piece will show up at the end of the distributor arm on your machine. You will then know that you have 75' of cable in the line. Now, let's suppose that the line you are cleaning requires more than 75' of cable.

This is the procedure to follow:

1. Disconnect the 75' of cable and leave it in the line. Insure that it cannot fall into the pipe beyond the opening.
2. Now, take the male end of your extension and add it to the 5' piece in the drum, feeding the whole extension piece into the drum. NOTE: The machine should be operating in the forward direction.
3. Hook up to the 75' piece in the sewer and resume rodding.

*NOTE: 100' of .55 magnum cable can fit in the drum at one time.

MAIN SEWER OR SEPTIC TANK OVERRUN

It is very important to know the approximate distance from inlet to main sewer or septic tank. Overrunning cable too far into main sewer or septic tank can allow cables to knot up and prevent their retrieval.

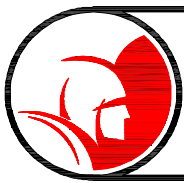

Maintenance Instructions



WARNING: Make sure machine is unplugged from the electrical system before making any adjustment.

INSTRUCTIONS FOR SPLICING OR REPAIRING CABLE

Splicing Cable (Standard Single Wound Cable)

Step One: Square ends of cable to be spliced or repaired by placing each end against a grinding wheel, grinding down so that the shoulder of splicer or coupling will butt squarely against the cable ends. (If splicing "INNER-CORE CABLE", and inner-core protrudes from cable at point of repair, pull the inner-core out of the cable just far enough to allow for the insertion of the connector. Then cut the inner-core off and push back into cable).

Step Two: Put cable in vice and open ends slightly with drive punch so that opening is just large enough to allow connector to be inserted.

Step Three: Clean splicer or coupling of rust or grease.

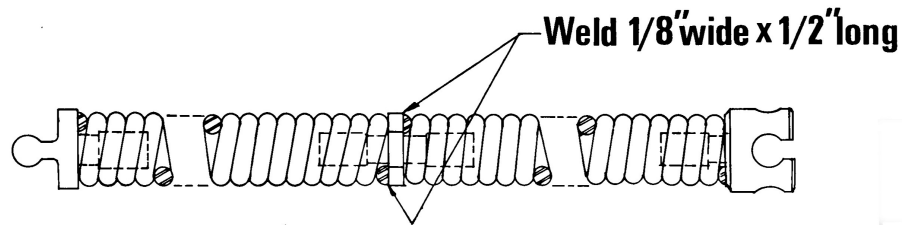

Figure 8

Step Four: Connect cables to splicer, or coupling and draw uptightly to shoulder of connector, as illustrated above.

Step Five: Put cable in vice and open ends slightly with drive punch so that opening is just large enough to allow connector to be inserted.

Splicing The .55 Magnum Cable and Installing New .55 Couplings

Item	Description	Part #
1	.55 Long Male Coupling	44110400
2	.55 Female Coupling	44110500
3	.55 Splicer	44114500
4	.55 Male Coupling	44111300
	or .55 Leader Male Coupling	44114300
5	Anchor Adapter .55 to 5/8	44291601

NOTE: Couplings and splicer for the .55 Magnum Cable are **not** interchangeable with 1/2" or 5/8" Spartan cable connectors.



Maintenance Instructions (cont.)



Step One: Grind cable square by placing the cable end against a grinding wheel. Care is to be taken to assure the innercore is flush with outer cable. Grind outer cable and innercore down enough to produce a flat contact surface between the cable and connector (splicer or coupling).

Step Two: Secure the cable into a vise, making sure innercore remains flush with outer cable.

Step Three: Clean connector and inside of cable from rust or dirt. (Care to be taken on cleaning connector threads.) Also it may be necessary to deburr inside of cable.

Step Four: Insert connector into innercore in the manner of tightening a right hand threaded screw. Tighten connector enough so that contact is made between outer cable and the connector face.

If required, step two through four should be repeated for the other cable end.

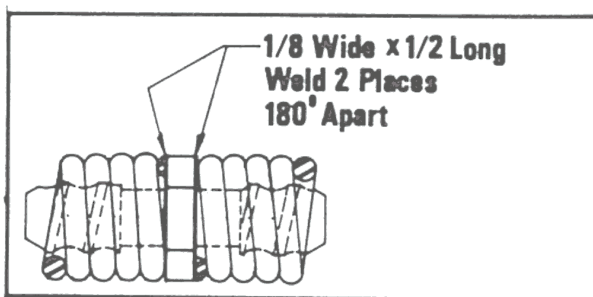

Figure 9

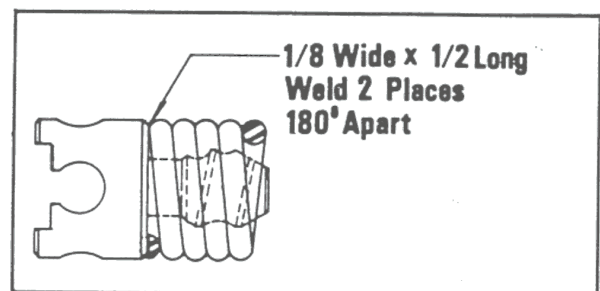

Figure 10

Step Five: Since the coupling and the wire in the cable are of high carbon steel, a special welding process is required. Before welding, use a propane torch to preheat the area where the weld will be. Hold the torch 4-5" away from the metal surface and heat for 2 minutes. Immediately, weld with an arc welder, using 3/32" diameter unit rod #70 or equivalent chromium-stainless steel rod. Use a heat range of 90-100 amps. Be sure weld bead is 1/8" wide and 1/2" long, where each wire end contacts the coupling.

After welding, it will be necessary to stress relieve the welded area. Again, using a propane torch holding 4-5" away from metal surface, heat up to approximately 5 minutes. Allow to cool and cable will be ready for use.

NOTE: Never heat the cable to a cherry red color. This indicates too high a temperature and will weaken the cable.



Maintenance Instructions (cont.)



CHANGING MOTOR BRUSHES:

WARNING: Make sure machine is unplugged from electrical system.

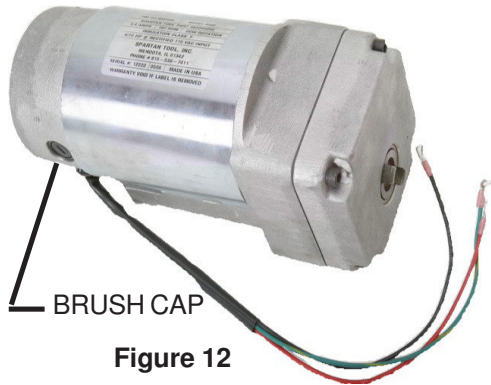

Figure 12

1. Unscrew brush cap. (See figure 12).
2. Remove brush, mark the top of the brush. Note the condition of brush end and brush length. If brush end is chipped or damaged in any way, replace brush. Brush length of 1/4" or less indicates time for replacement.
3. If brush is still good, replace into holder or; if not good, replace with new brush. Repeat procedure on other side then assemble cover and your machine is ready to run.

NOTE: If new brushes are used, run the machine for about 5 minutes before operating. Check brushes every 300 hours of operation and replace motor brushes every 5 years.

CARING FOR CABLES:

NOTE: A new 5' anchor cable should be replaced each time new cable is installed.

Spartan cables are of such design that no special care is required. At the end of each day of use, cables and the inside of drum should be rinsed thoroughly with water to prevent damaging effects of drain cleaning compounds, acids and other organic compounds that eat away the cable's strength.

Cables should be replaced when they become severely corroded or worn. A "worn cable" can be identified when outside coils of cable become flattened and/or the cable becomes limber. A light weight rust inhibiting oil is recommended for use on cables when not in use. This serves to delay the effects of acid but only for a limited time.

NOTE: Worn or corroded cable reduce the machine efficiency in removing obstructions. New cable reduces chances of downtime and the time it takes to get the job done.

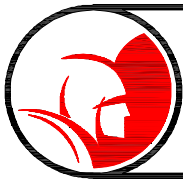

Maintenance Instructions (cont.)



How To Install 5' Drum Anchor Cable

1. Position external drum in a vertical position so that cable can be inserted into the drum horizontally through the distributor arm.
2. Rotate the external drum until the heads of the cable clamp screws on the back of the drum indicate that the clamp is at the top of the drum. Unscrew the cable clamp screws to loosen the cable clamp inside the drum; DO NOT loosen these screws too much, as the cable clamp may become unfastened. (If this should occur, refer to the instructions for removing the inner drum in order to retrieve the cable clamp.) Remove old cable from drum.
3. Face the machine from the front. Place your left hand on top of the external drum; press the heads of the cable clamp screws forward with two fingers of your left hand, steadying the external drum with the palm of your left hand. Sight through the cut-out in the cover of the external drum and rotate the inner drum with your right hand; position the inner drum so that the distributor arm is aligned slightly to the right of the cable clamp. See Figure 1.
4. Allow the inner drum to rotate freely in a clockwise direction as you feed sufficient cable through the distributor arm into the external drum to position the cable within the external drum as illustrated in Figure 2.
5. Maintain the position of your left hand on the clamp screws and the top of the external drum as previously indicated above. Grasp the inner drum firmly with your right hand and rotate it counter-clockwise to the left with a snappy movement. This snappy motion will thread the non-working end of the cable into the correction position within the cable clamp. Tighten the cable clamp screws securely.

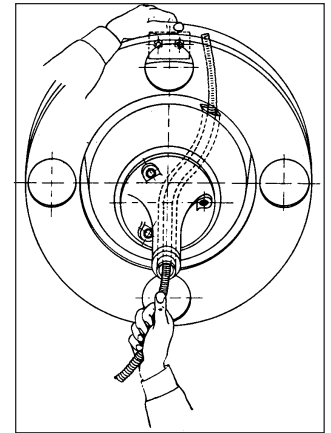

Figure 13

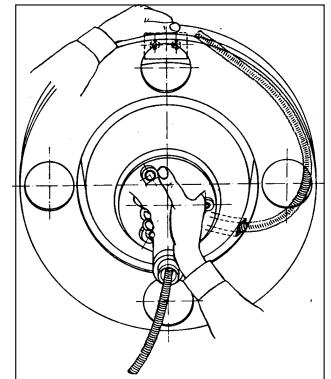
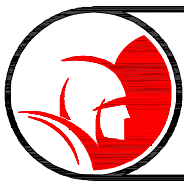

Figure 14

MACHINE STORAGE:

Electric motor driven equipment must be kept indoors or well covered in rainy weather.

NOTE: After every job rotate drum so that the drain hole in the drum is on the bottom to allow for drainage before storage. A light weight rust inhibiting oil is recommended for use on cables when not in use.



Model 300

04221458

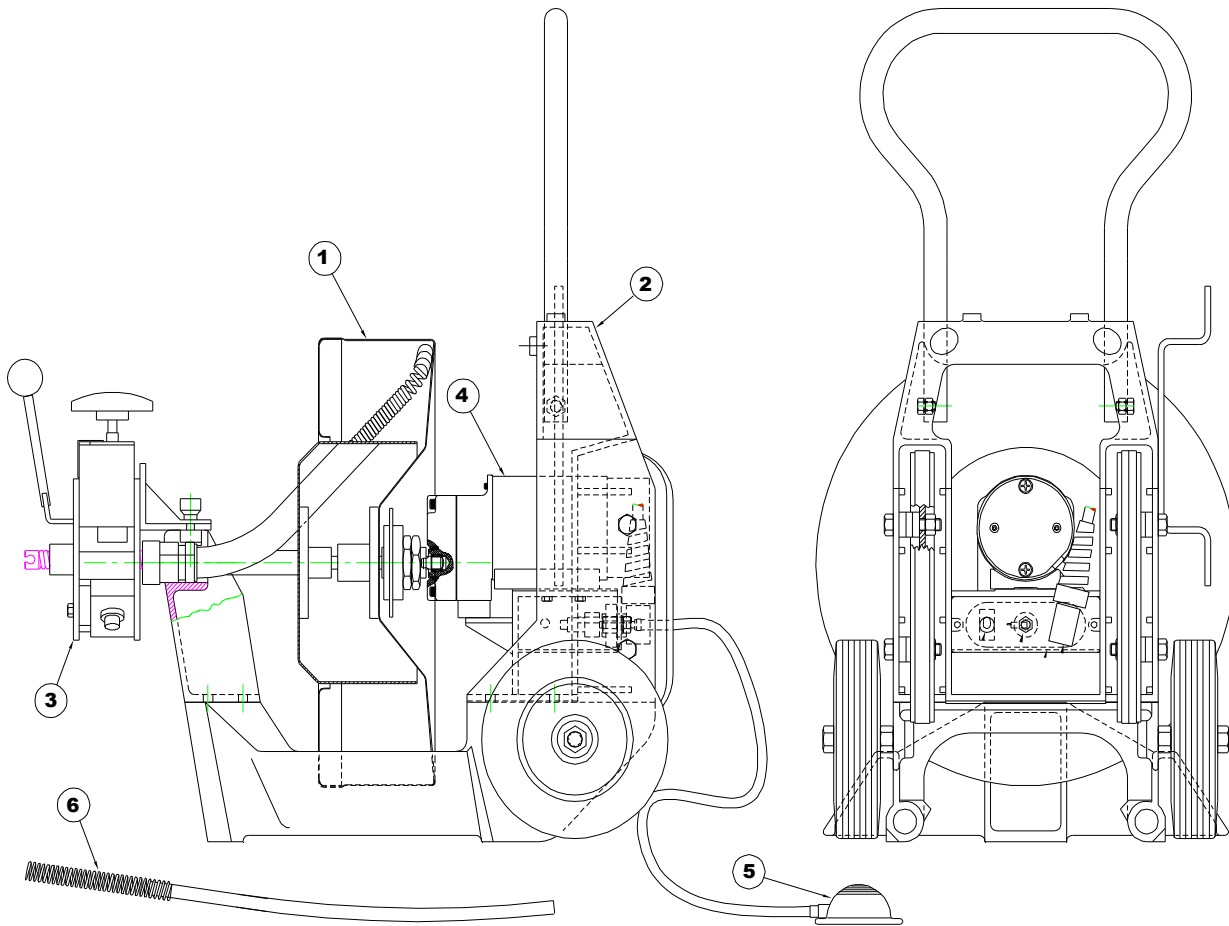
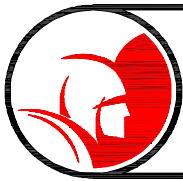

Figure 15

Item	QTY	Part #	Description
1	1	44129300	Model 300 Drum Complete
2	1	04217000	Frame, 300
3	1	04221000	Power Feed
4	1	44290200	PM Motor w/Gearbox-300
5	1	44225800	Air Bulb & Hose Assembly
6	1	44225300	Cable Guide Assy



Model 300 Drum Complete

44129300

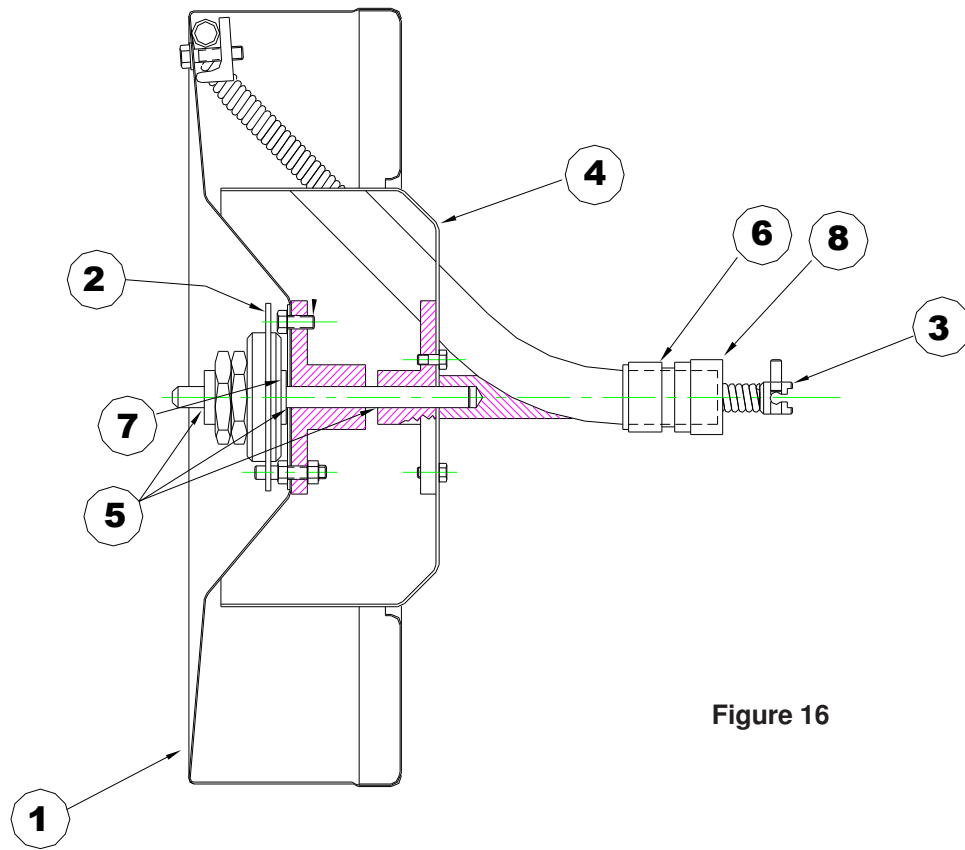
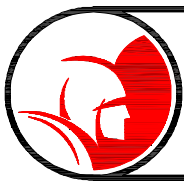

Figure 16

Item	Qty	Part #	Description
1	1	02875900	External Drum Assy (300)
2	1	04203300	Clutch Assy 5/8
3	1	44292700	Assy, Universal Anchor .55
4	1	02875300	Model 300 Internal Drum
5	2	02822500	Retaining Ring-Small
6	1	02873600	Distributor Arm Bushing
7	1	02890300	Sintered Bronze Thrust Washer
8	1	03407100	Set Collar Assembly 300



External Drum Assembly 02875900

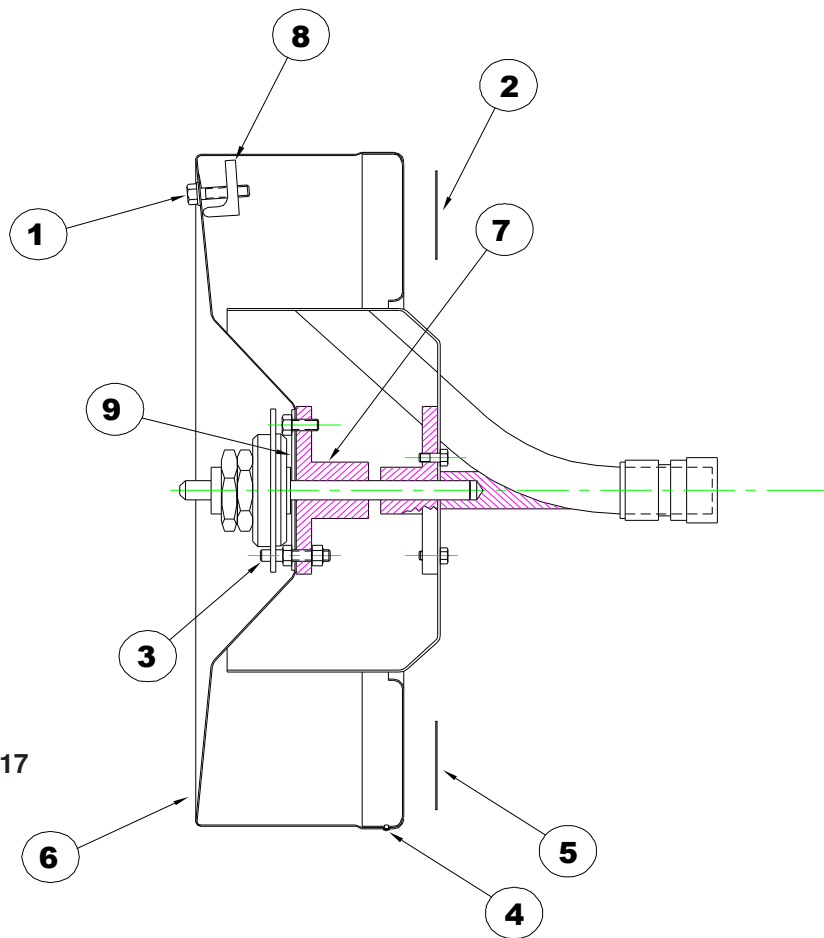

Figure 17

ITEM	QTY	PART NUMBER	DESCRIPTION
1	2	00115600	Screw, Hex HD Cap 5/16-18 X 1-1/4
2	1	02761200	Decal, Spartan Warning
3	2	02890200	300 Drive Stud
4	1	44039500	Rivet, Pop 1/8 Dia.
5	1	44052700	Decal Drum Model 200 & 300
6	1	04203500	Outer Drum & Cover 300
7	1	04203000	Drum Hub Assy 300
8	1	02885000	Cable Clamp Assy
9	1	02890000	300 Reinforcing Plate

Figure 19



Clutch Assembly 04203300

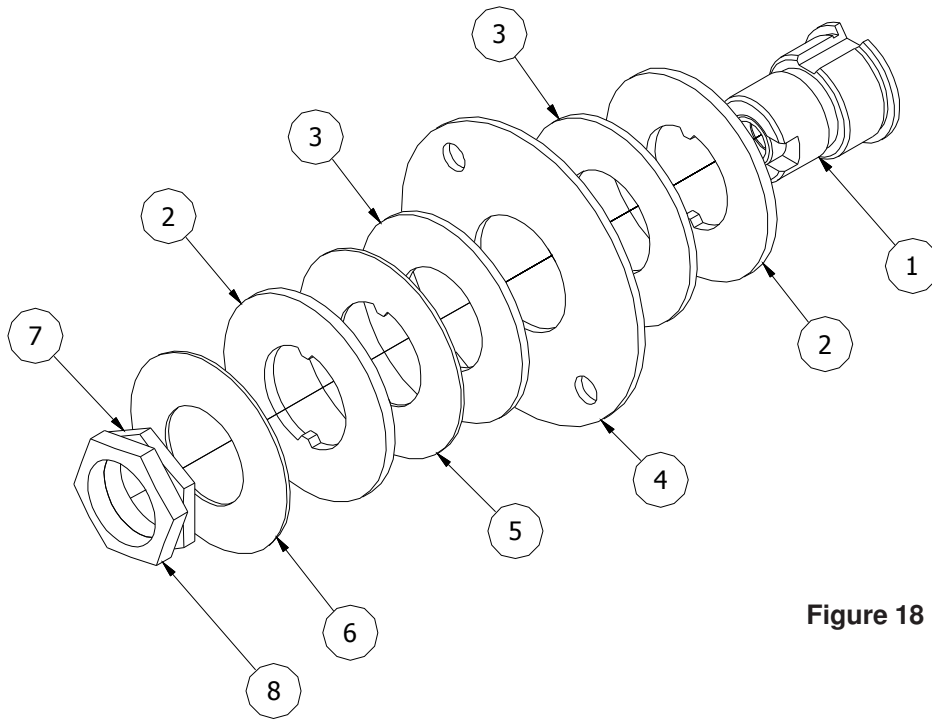
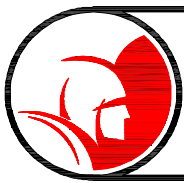

Figure 18

ITEM	QTY	PART NUMBER	DESCRIPTION
1	1	03414200	Clutch Hub & Bearing Assy
2	2	02760300	Plate Drive Mod 100
3	2	02760400	Clutch Facing, Scan-Pac
4	1	02760800	Plate, Friction
5	1	04237000	Spacer 1.50 x 3.00 16 GA
6	1	02760500	Spring Clutch
7	1	02866300	Shouldered Adjusting Nut
8	1	02760700	Nut Adjusting



Model 300 Internal Drum

02875300

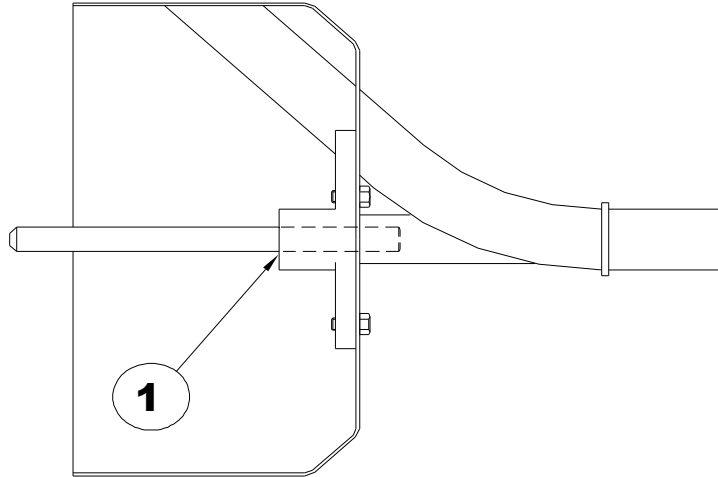

Figure 28

ITEM	QTY	PART NUMBER	DESCRIPTION
1	1	04202600	Drum Shaft Bracket Assy 300



Model 300 Frame Assy 04217000

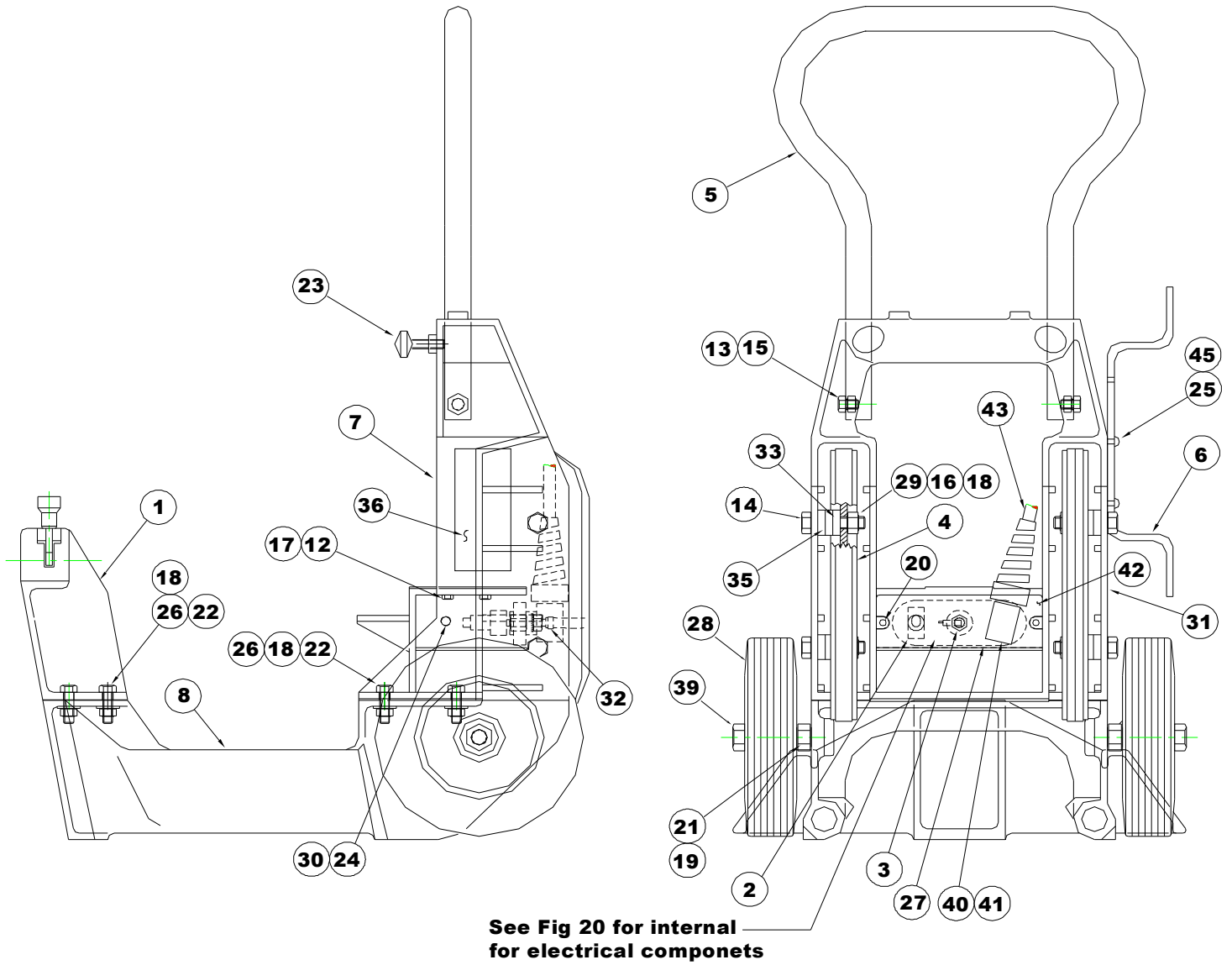

Figure 19



Wiring Diagram

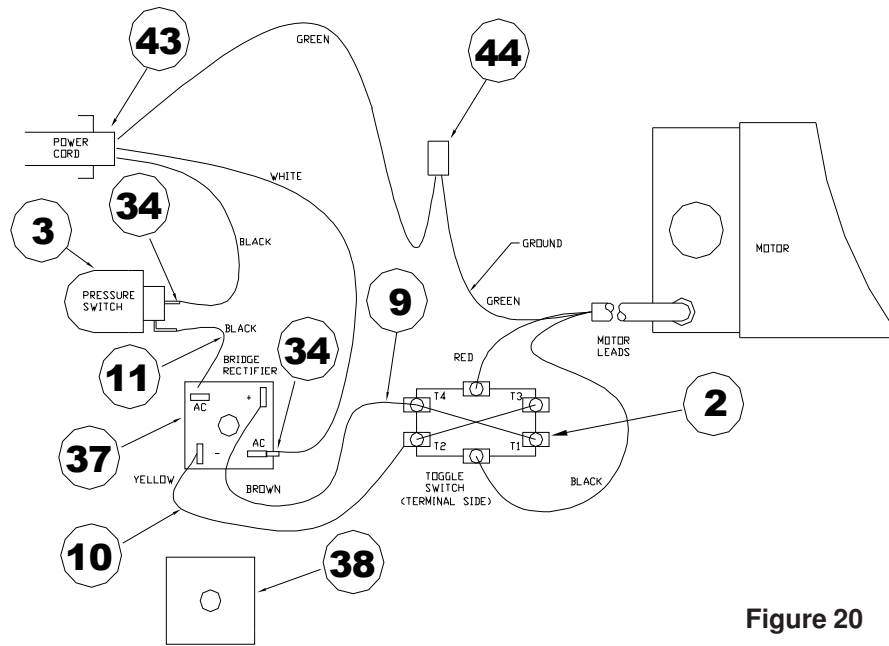
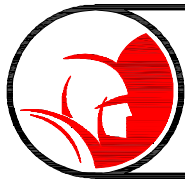

Figure 20

View of internal electrical components

Item	Qty	Part Number	Description
2	1	44221500	Forward Reverse Switch
3	1	44002600	Pressure Switch
9	1	44290700	Assy. Jumper Wire 5" Brown
10	1	44290800	Assy. Jumper Wire 5" Yellow
11	1	04647800	Assy. Jumper Wire 5" Black
34	2	44216100	Disconnect, .250 Female 16-14
37	1	44290500	Bridge Rectifier PM Motor
38	1	44290501	Pad, Thermo - Conductive
43	1	71103300	Power Cord 25' W/G.F.I.
44	1	79925700	Connector-Push-On 2 Wire



Model 300 Frame Assy 04217000



ITEM	QTY	PART NUMBER	DESCRIPTION
1	1	04202700	300 Auto Upper Front Cstg
2	1	44221500	Forward Reverse Switch
3	1	44002600	Pressure Switch
4	2	04205500	Crawler Tread Assy Universal
5	1	04206100	Handle Assy
6	1	44280900	Kit, Cord Wrap
7	1	02870500	Casting, Back 300 (Machined)
8	1	02871600	Lower Casting (Almag) 300
9	1	44290700	Jumper Wire, 5 in Brown
10	1	44290800	Jumper Wire, 5 in Yellow
11	1	44292200	Jumper Wire, 4 in Black
12	4	00113700	Screw, Hex Hd Cap 1/4-20 x 3/4
13	2	00116000	Screw, Hex Hd Cap 1/4-20 x 1/2
14	4	00116900	Screw, Hex Hd Cap 3/8-16 x 3/4
15	2	00140000	Square Nut 3/8-16 zinc plated
16	4	00162700	Washer, Flat 3/8 USS zinc pltd
17	4	00165400	Washer, Lock-split Medium 1/4
18	10	00167200	Washer, 3/8 Internal Tooth Lock
19	2	00167600	5/8 Lockwasher
20	2	01955201	Screw, Machine SLT 1/4-20 x 1/2
21	2	02820800	Nut, Hex Jam 5/8-18
22	6	02821100	Nut, Hex 3/8-24
23	4	02822400	Screw, Thumb 3/8-16 x 1
24	1	02823900	Screw, Machine 10-32 x 1
25	2	02824000	Phillips Fillister HD Mach
26	6	02826500	Screw, Hex Hd 3/8-24 x 1-1/4
27	2	02890100	Insulation Paper 2-3/16"
28	2	02897800	Rubber Tired Wheel 8 x 2.50
29	4	02934100	3/8-16 Hex Nut zinc pltd
30	1	03850100	Nut, Hex KEP 10-32 zinc pltd
31	1	04220200	Decal, Warning
32	1	04652700	Clamp, Stepless Ear 1/2"
33	4	44073500	Spacer or Small Standoff
34	2	44216100	Disconnect, .250 Female 16-14
35	12	44239600	Spacer-Nylon Flat Washer
36	1	44281400	Decal, 1065, 300,2001 Safety
37	1	44290500	Bridge Rectifier, PM Motor
38	1	44290501	Pad, Thermo-Conductive
39	2	44302400	Screw, Hex Hd Cap 5/8-18 x 3-1/2
40	1	44302800	Strain Relief-RT Angle
41	1	44302810	Nut, 1/2 NPT Nylon
42	1	44302900	Cover Outlet Box Mod 300
43	1	71103300	Power Cord 25' w/G.F.I.
44	1	79925700	Connector-Push-On 2 Wire
45	2	03850100	Nut, Hex KEP 10-32 zinc pltd

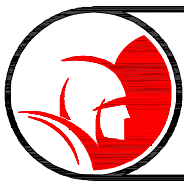

PM Motor w/Gearbox 300

44290200

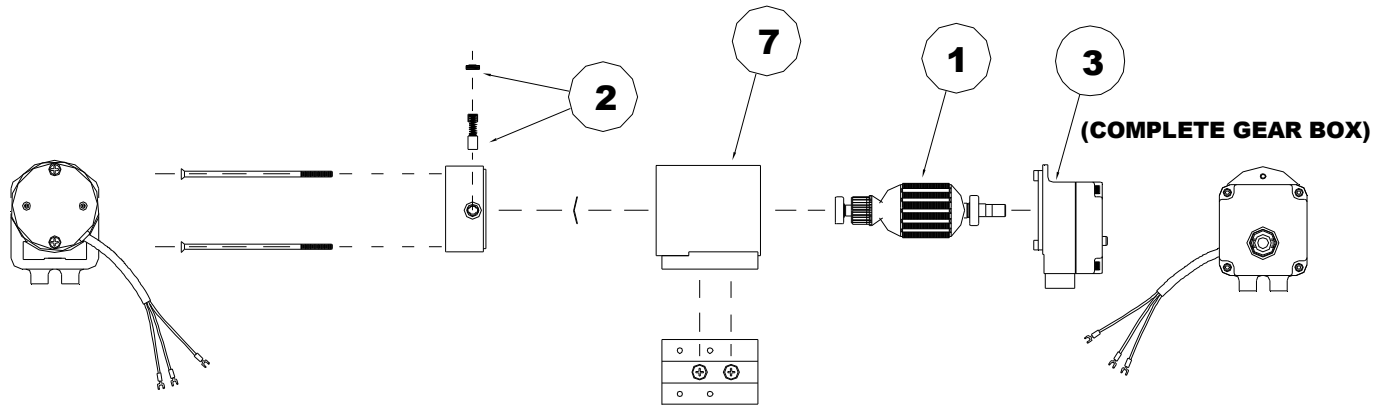

Figure 21

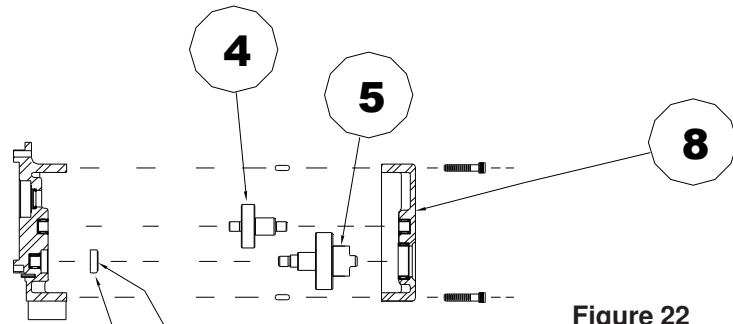
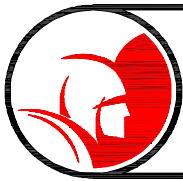

Figure 22

**FACE THAT ROTATES
FACING THIS SIDE
TOWARDS GEAR**

Item	Qty	Part #	Description
1	1	44304320	110V Armature & Brg 300 PM
2	1	44304000	Brush Kit 100-300-1065-2001
3	1	44304300	Gearbox Mod 300 PM
4	1	44304350	Pinion Gear 300 PM
5	1	44304340	Output Gear 300 PM
6	1	44304360	Bearing, Thrust 300 PM
7	1	44304420	Base, 1065 & 300 PM Motor
8	1	44304370	Cover, 300 PM Gear Case



300 Auto Upper Front Cstg

04202700

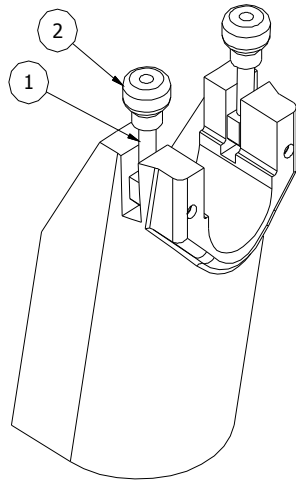

Figure 23

		PART	
ITEM	QTY	NUMBER	DESCRIPTION
1	2	04201200	Swing Bolt Assy
2	2	03410500	Adjustable Knob



Assy, Universal Anchor .55

44292700

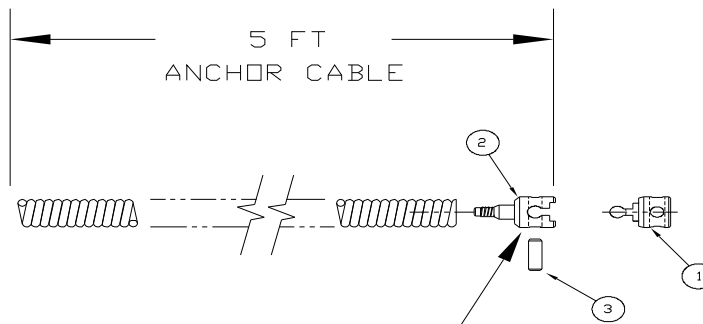
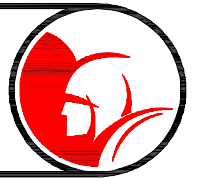
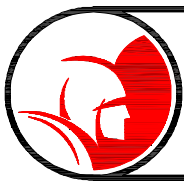

Figure 24

		PART	
ITEM	QTY	NUMBER	DESCRIPTION
1	1	44291601	Assy, Anchor Adapter .55-5/8
2	1	44113100	.55 Female Coupling
3	1	44117400	Roll Pin Carbon Steel



5/8" Cable



5/8" Inner-Core

Dia - Lth	Part No
5/8" x 25'	03441702
5/8" x 50'	03441703
5/8" x 75'	03441704
5/8" x 100'	03441705

5/8" No-Core

Dia - Lth	Part No
5/8" x 25'	00408901
5/8" x 50'	00408902
5/8" x 75'	00408903

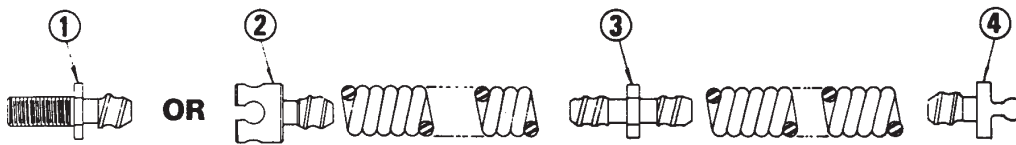

Part Number Listing (For 5/8" Cable)

- (1) = Long Male Coupling 02878200
- (2) = Female Coupling 02878000
- (3) = Splicer 02878300
- (4) = Male Coupling 02878100
- (5) = Anchor Adapter 44291600

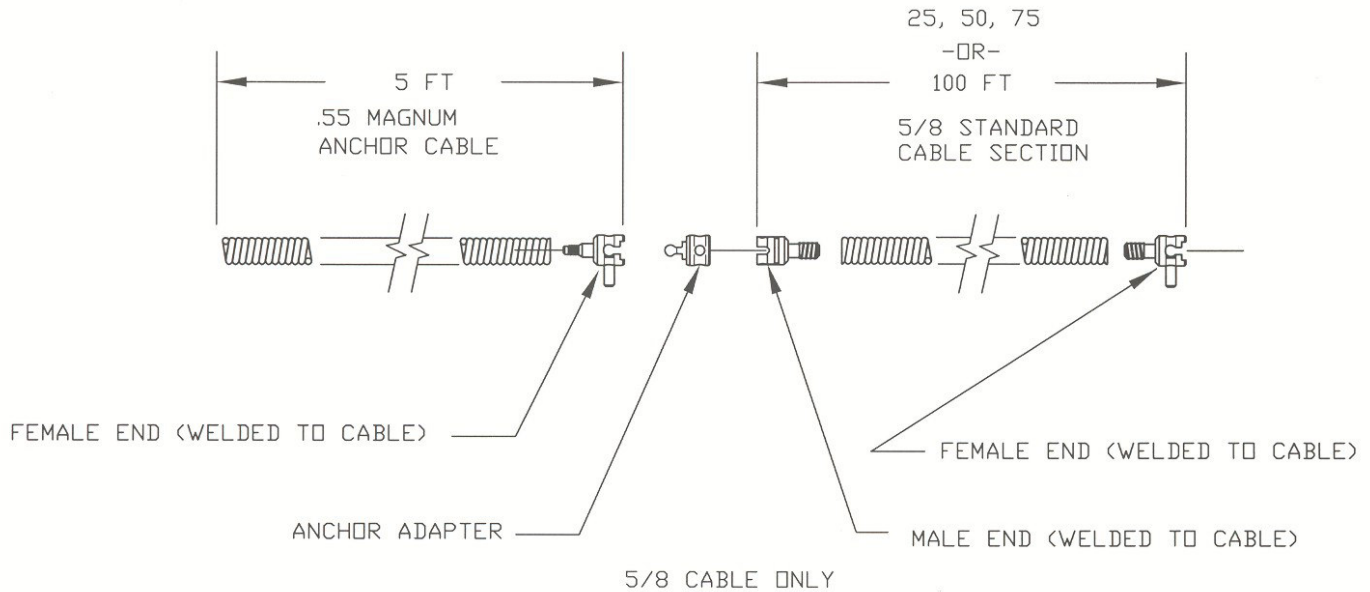

44292700 Universal Anchor Cable Assy .55-5/8

1	44117400	.55 Expansion Pin
1	44117500	Anchor .55 x 5 Magnum
1	44291601	Adapter, Anchor .55 - 5/8
1	02882200	5/8 Expansion Pin



.55 Magnum Cable



Splice connector shown fully seated ready for welding

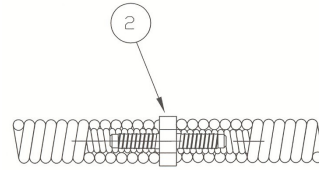

Part Number Listing (For .55 Mag Cable)	
(1) = .55 Female Coupling	44133100
(2) = .55 Splicer	44114500
(3) = .55 Male Coupling	44133000

Dia - Lth	Part No
.55 x 50'	44128700
.55 x 10'	44128703
.55 x 2'	44116900

OUTER CABLE CUTAWAY TO SHOW INNER CORE

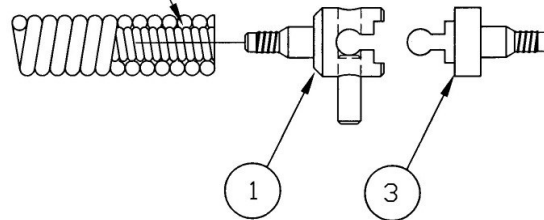

FEMALE END SHOWN THREADED INTO INNER CORE

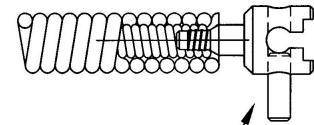

Note: Couplings and splicer for the new .66 magnum cable are *not* interchangeable with 3/4" or 5/8" Spartan cable connectors.

FEMALE END SHOWN FULLY SEATED READY FOR WELDING

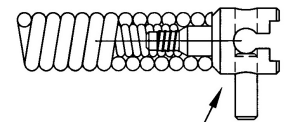



Air Bulb & Hose Assembly 44225800

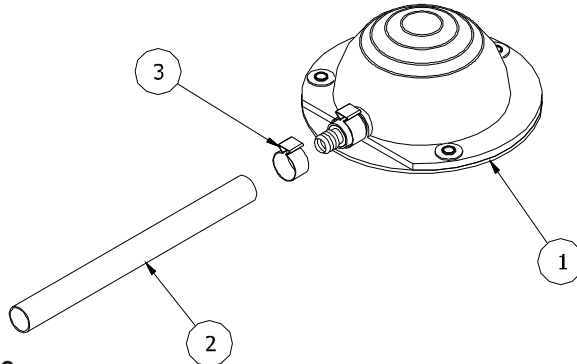

Figure 26

PART			
ITEM	QTY	NUMBER	DESCRIPTION
1	1	04576900	Pressure Transmitter
2	1	04577100	Air Hose, 8'
3	2	04652700	Hose Clamp



Optional Compact Lift - 02884900

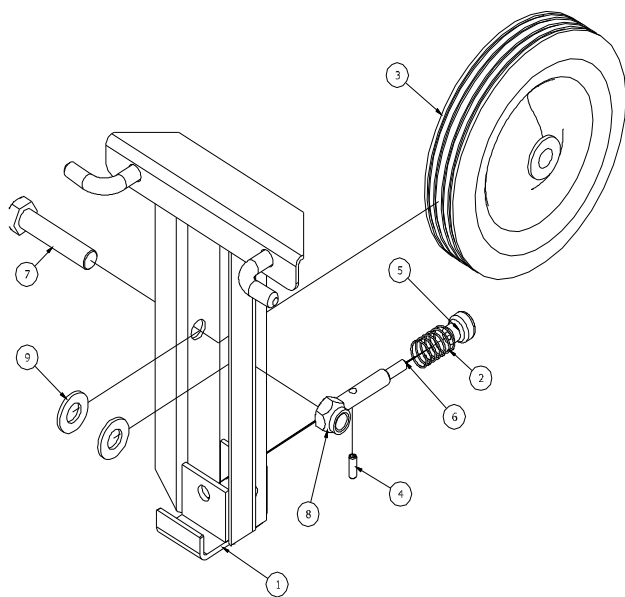
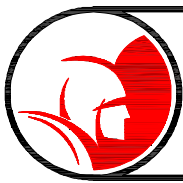

Figure 27

Item	Part No	Req'd	Description
1	02888700	1	Rail & Hook Assembly
2	02888500	1	Spring
3	02811900	1	Wheel, Model 100/200
4	02821800	1	Pin, Roll 1/4 Dia X 3/4
5	03410500	1	Adjustable Knob
6	02887600	1	Locating Pin
7	02826200	1	Screw, Hex Hd 5/8-18 x 3
8	02821300	1	Stop Nut 5/8-18
9	00760400	2	Washer, Flat 5/8 SAE



Optional Model 100 Drum Adapters



Part #	Description
02766401	Model 100 Drum Assembly with 13/32 Clutch (Does Not Include Items 141 & 142)
02766402	Model 100 Drum Assembly with 1/2 Clutch (Does Not Include Items 141 & 142)
02766403	Model 100 Drum Assembly with 5/16 Clutch (Does Not Include Items 141 & 142)

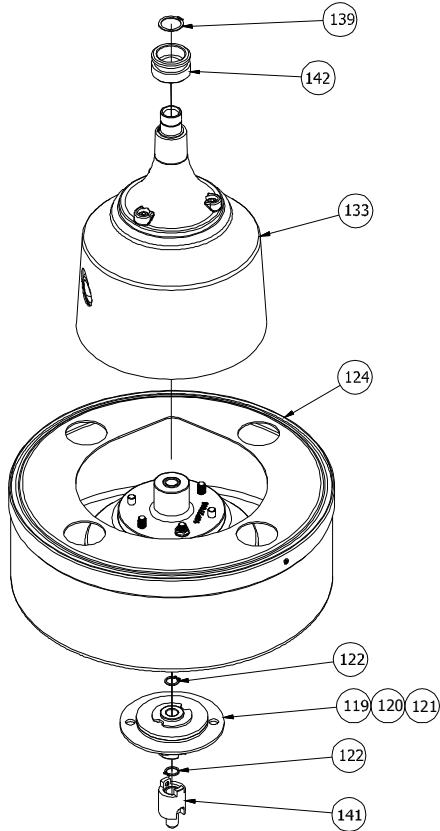
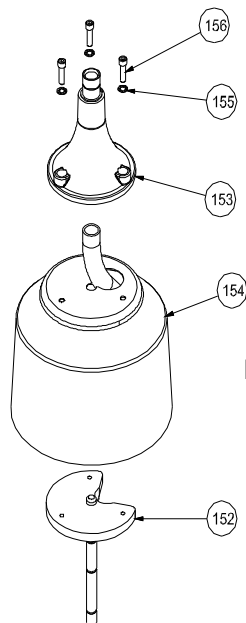
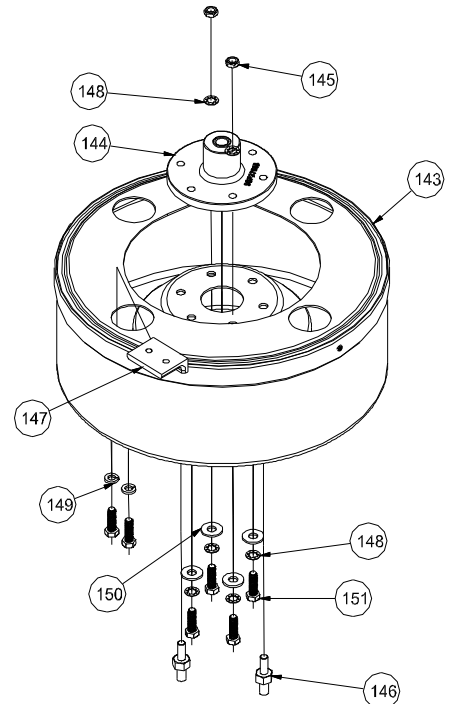

Figure 11

Item	QTY	Part #	Description
124	1	02766500	Complete Outer Drum Mod 100
119	1	04203200	Clutch Assy-13/32
120	1	04204200	Clutch Assy-1/2
121	1	04204300	Clutch Assy-5/16
133	1	02766600	Inner Drum & Spinning
122	2	02822500	Retaining Ring - Small
139	1	02822700	Retaining Ring - Small
141	1	02887300	Rear Drum Adapter Assembly
142	1	04203800	Front Adapter Assembly (Includes Item 139)
143	1	02767600	Outer Drum & Cover Assy Mod 100
144	1	02765700	Drum Hub Assembly
145	2	02820700	Nut, Heavy Hex Jam 5/16-18
146	2	02765600	Drive Stud
147	1	02765500	Clamp Cable
148	6	00167100	Internal Tooth Lockwasher
149	2	00165600	Kantlink Lockwasher
150	4	00162600	Washer, Flat 3/8
151	6	00115100	Screw, Cap Hex Hd 5/16-18x 1
152	1	02760100	Mainshaft Assembly
153	1	02759900	End Bracket Assembly
154	1	02767500	Drum Internal Mod 100
155	3	00167000	Internal Tooth Lockwasher
156	3	02827200	Screw, Cap 1/4-20x7/8



Item 133



Item 124



Tool Box and Accessory Kit

44129400 .55 Cable 04646900 5/8 Cable



44129400 .55" Tool Box

04646900 5/8" Tool Box

Item	QTY	Part #	Description
181	1	02883200	Uncoupling Stand
183	1	02752500	Tool Box Red W/ Tote Tray
184	1	03406800	"T" Wrench
185	1	02893900	Glove- Pair
186	1	02807700	Retriever LG Female CPLG
187	1	02798800	Spear Blade Cutter
188	1	02799100	3" P-Trap Blade
189	1	02799200	3-1/2" P-Trap Blade
190	1	02799000	2" U-Blade (1065-300-200)
191	1	03400600	2-1/2 Inch Blade
192	1	02786600	3 Inch Blade
193	1	02790900	4 Inch Blade
194	1	02799500	P-Trap Blade Holder
195	1	02799300	2" & 2-1/2" Blade Holder
196	1	02799400	3"-4"-6"-8" Blade Holder
197	1	02790800	Blade Retainer
198	1	44113100	.55 Female Coupling
199	1	44113000	.55 Male Coupling
200	1	44114400	.55 Long Male Coupling
201	1	44114500	.55 Splicer
202	6	44117400	Roll Pin Carbon Steel
203	1	03441608	Leader 5/8 x 2 ICNT#5
207	1	44054900	.66 & .55 Pin Punch
208	1	44114200	.55 Double Male Coupling
209	3	00167200	Washer-Shakeproof
210	3	02821100	Nut, Hex 3/8-24
211	1	44114300	.55 Male Leader Coupling (Not Shown)

Item	QTY	Part #	Description
181	1	02883200	Uncoupling Stand
183	1	02752500	Tool Box Red W/ Tote Tray
184	1	03406800	"T" Wrench
185	1	02893900	Glove- Pair
186	1	02807700	Retriever LG Female CPLG
187	1	02798800	Spear Blade Cutter
188	1	02799100	3" P-Trap Blade
189	1	02799200	3-1/2" P-Trap Blade
190	1	02799000	2" U-Blade (1065-300-200)
191	1	03400600	2-1/2 Inch Blade
192	1	02786600	3 Inch Blade
193	1	02790900	4 Inch Blade
194	1	02799500	P-Trap Blade Holder
195	1	02799300	2" & 2-1/2" Blade Holder
196	1	02799400	3"-4"-6"-8" Blade Holder
197	1	02790800	Blade Retainer
198	1	02878000	Female Coupling 5/8 Cable
199	1	02878100	Male Coupling 5/8 Cable
200	1	02878200	Long Male Coup 5/8 Cable
201	1	02878300	Splicer-5/8 Inch Cable
202	6	02882200	Pin For 5/8 Inch Cable
203	1	03441608	Leader 5/8 x 2 ICNT#5
207	1	02819100	Punch For 3/4 & 5/8 Cable
208	1	04204100	Coupling Double Male
209	3	00167200	Washer-Shakeproof
210	3	02821100	Nut, Hex 3/8-24

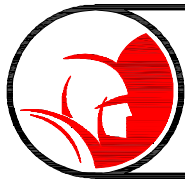

Pneumatic Tire Upgrade Kit 44250700



Item	Qty	Part No	Description
1	1	44218000	Axle
2	1	44250900	Casting, Wheel Adapter LH
3	1	44251000	Casting, Wheel Adapter RH
4	2	50HW12F0	Washer, Flat
5	2	50H61600	Screw, Hex Hd
6	2	71100700	Tire, 10" 1/2-13 x 1 1/2
7	2	77747600	Cotter Pin 1/8 x 1
8	2	77759900	Screw, Hex Head 3/8-16 x 1 1/4



300 Hoist Bracket Upgrade Kit 44295810



Item	Qty	Part No	Description
1	1	44295800	Bracket, Hoist 300
2	1	44296100	Instruction Sheet 300 Hoist
3	2	02934100	3/8-16 Hex Nut
4	2	00116900	Screw, Cap Hex HD 3/8-16 X 1-3/4



Spartan Accessory Blades



02799000 2" U-Blade



02799100 3" P-Blade



44261000 2" Double Cutter



03416600 3" Grease Blade



02786601 3" Half Blade



03400600 2 1/2" Blade



02799200 3 1/2" P-Trap Blade



02786600 3" U-Blade



03416700 4" Grease Blade



02790901 4" Half Blade



02799300
2 - 2 1/2" Blade Holder



02799500 P-Trap Blade Holder



44165200 4" Knife Blade



44006700 2 1/2" Round Cutter



02798800 Spear Blade



02807700 Retriever



02813500 6" U-Blade



44161300 3" Knife Blade



02813501 6" Half Blade



44052600 Boring Tool



02818400 8" U-Blade



02798700 3 1/2" Saw Blade



03406800 T-Wrench



02797500
Tri Blade Holder



02799600 2" Single Blade



02791700 3" Single Blade



02791800 4" Single Blade



02870300 6" Single Blade



02799400 3" - 4" - 6" Blade Holder



MODEL 75

Power Cable Feed Section



Operating & Maintenance Instructions





Power Cable Feed Section Table of Contents



Introduction	36
Attaching the Cable Safety Guide	37
Setting Your Cable Size	38
04221000 Universal Power Feed	39
44224200 Model 2001 Power Feed	40
04217500 Power Feed Assembly	41
04224000 Bearing Block Assy (Long)	42
44219900 Bearing Block Assy (Short)	43
44119600 Wheel Carrier Body (Long)	44
44119700 Wheel Carrier Body (Short)	44
Model 1065 & 2001 Installation	45
Model 200 and 300 Installation	46
Model 100 Installation	47
Operating Instructions	48
Cleaning Operation	49
Disassemble & Reassemble Power Feed	49
Disassembly of Short Bearing Blocks	50
Disassembly of Long Bearing Blocks	51
Cleaning & Lubricating Instructions	52
Re-Assembly of Short Bearing Blocks	52
Re-Assembly of Long Bearing Blocks	53
Cable Safety Guide Instructions	54-55



Introduction



The Spartan Tool Model 75 Power Cable Feed with “dial-a-cable” reflects the latest improvements in the marketplace. The operation, repair and maintenance of the Model 75 are simple to accomplish. These features allow a quick change for cable size and provide easy maintenance. The Model 75, which weighs just over 10 pounds, will feed and retrieve a cable up to 30 feet per minute.

A universal mounting plate allows adaptation to current Spartan Model 1065's, 200's, 300's, and 100's. (The Model 2001 does not need a mounting plate.) The power cable feed can be used on cable size from 5/16” through 3/4”.

Spartan Tool, L.L.C. strongly recommends the use of a Spartan Cable Safety Guide (44225300) with the Model 75 Power Cable Feed unit. (See Fig. 1) The Cable Safety Guide attaches to the front of the Model 75 unit, and is intended to help protect the operator from possible cable buckling and other hazards associated with handling rotating cable. Contact Spartan Tool, L.L.C. (800 435 3866) or www.spartantool.com with questions regarding the Cable Safety Guide.



Attaching the Cable Safety Guide To The Power Cable Feed



Disconnect the cable machine from its power source to avoid accidental starting. Pick up the Cable Safety Guide and place the spring against the hub on the Power Cable Feed and turn it counterclockwise until the spring rests against the plate behind the hub.

Reconnect the power by plugging in the machine. Insure the electrical switch on the machine is in the forward position. Insure the adjusting knob on the feed has been tightened until it makes contact with the cable. Place the lever (actuator assembly) midway between the “N” (Neutral) and “F” (Forward) position to allow the cable to enter the Cable Safety Guide slowly. Depress the foot pedal to engage the machine and allow the end of the cable to exit the Cable Safety Guide. Release the foot pedal.

Disconnect the machine from its power source, and attach the selected tool to the cable. Move the machine as close to the entry point of the pipe as possible. The end of the Cable Safety Guide and attachment should be within inches of the pipe. Reconnect the power.



Warning: Unexpected machine start up can cause death or severe injury.

Disconnect the machine from its power source before installing, servicing or removing the Power Cable Feed, Cable Safety Guide, cable tools and cutters, or other machine components.

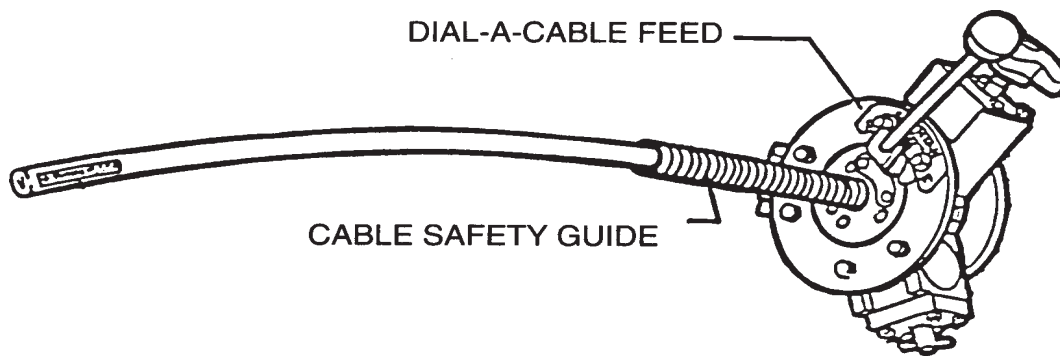

Fig. 1



Setting Your Spartan Power Cable Feed for Cable Size



(Refer to Fig. 2 for details)

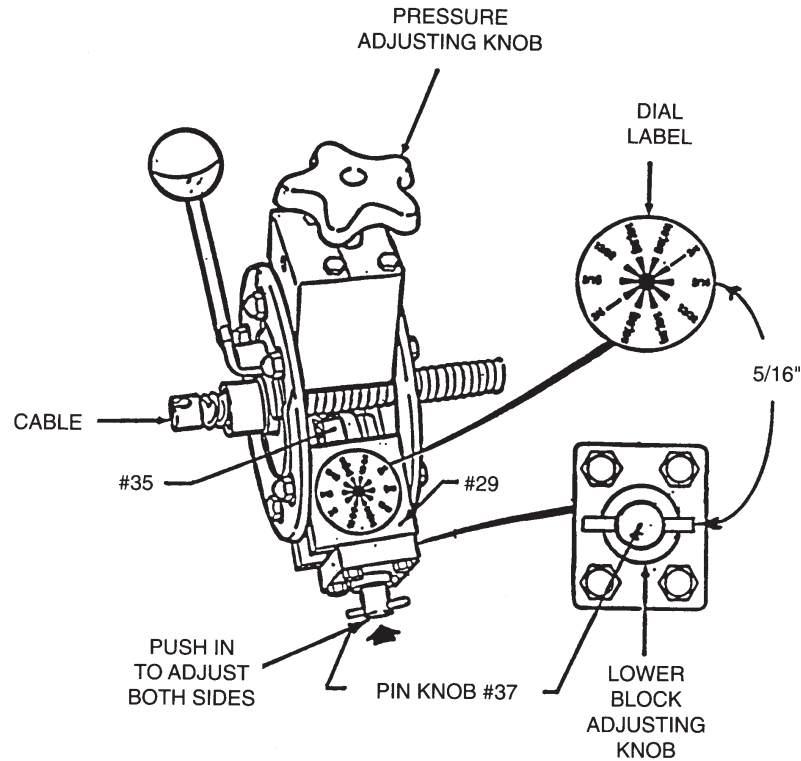

Fig. 2

To adjust for cable size, push in on the pin knob (#37) located on the bottom of the bearing blocks (#29) to unlock from setting. Turn pin knob right/clockwise and pull out. As each cable setting is reached the knob can be felt locking in. The body assembly (#35) will move in for smaller cable diameters and out for the larger diameter. As a starting point, push in and turn the pin knob so the pin in the knob is horizontal (in line with the cable). This setting should match the dial label for 5/16" cable setting. (The figure in the center of the dial label indicates pin knob setting if viewed from the block end.) The body assembly should be in to it's farthest point. Now, by pushing in and turning the pin knob right/clockwise pulling out at the next step should lock into the 13/32" setting, the next 1/2", etc. The body assembly will become longer with each rotational movement until returned to the 5/16" setting (horizontal). Rotating your Dial-A-Cable through the various settings and matching the dial label will make it easy to adjust cable size by feel.

Cable Diameter (Inches)	Set Power Cable Feed
5/16"	5/16"
3/8" or 13/32"	13/32"
1/2" or .55"	1/2"
5/8" or .66"	5/8"
3/4"	3/4"

Fig. 3

Follow the chart (Fig. 3) to set your Dial-A-Cable for the cable size you have selected. Make sure both right and left block settings are the same.



04221000

Model 75 Universal Power Feed



(Universal Unit Fits 100-200-300-1065 Machines)

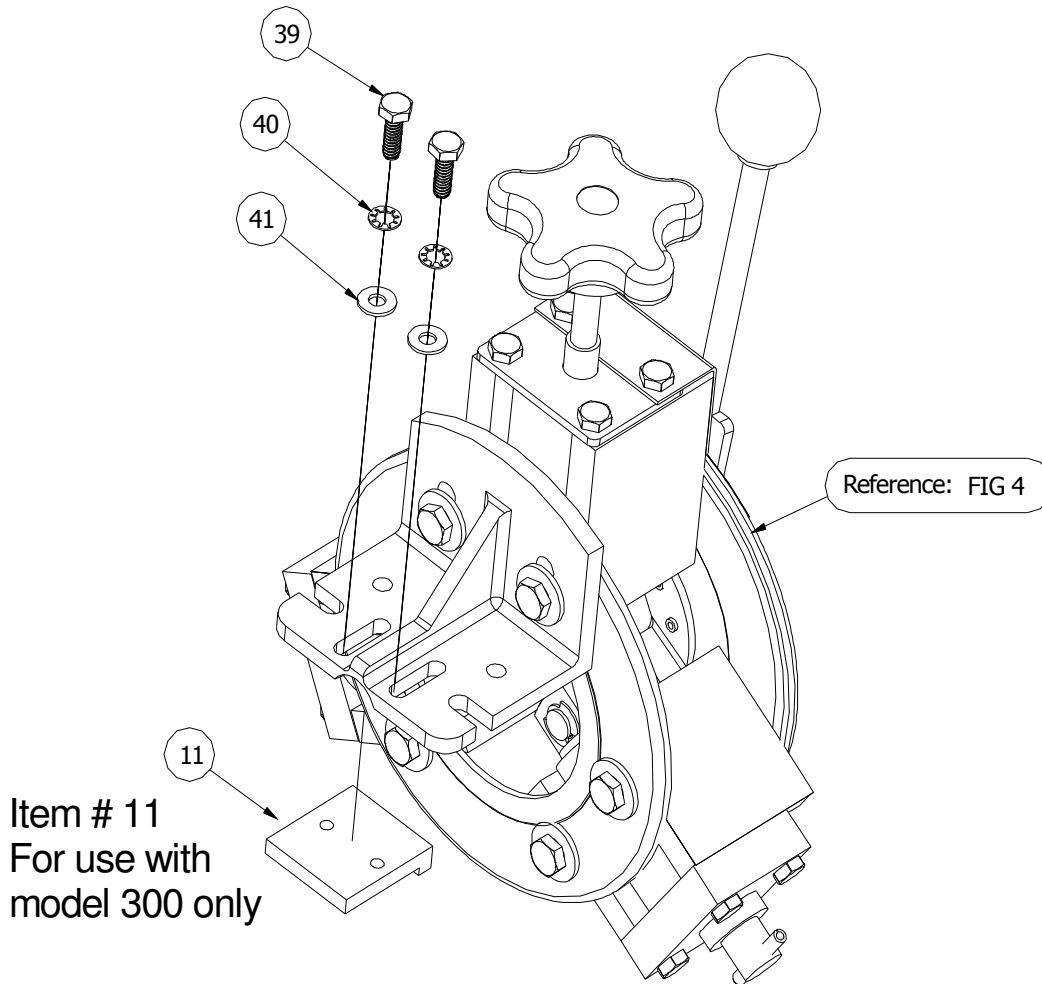
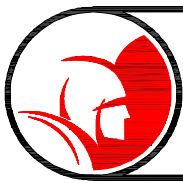

Fig. 14

ITEM	QTY	PART NUMBER	DESCRIPTION
11	1	03409000	Bushing Lock
39	2	00113600	Screw, Hex Hd 1/4-20 x 3/4
40	2	00162400	Washer, Flat 3/16 USS
41	2	00167000	Lockwasher, Internal Tooth
FIG 4	1	04217500	Power Feed Model 75



04217500 Power Feed Assembly

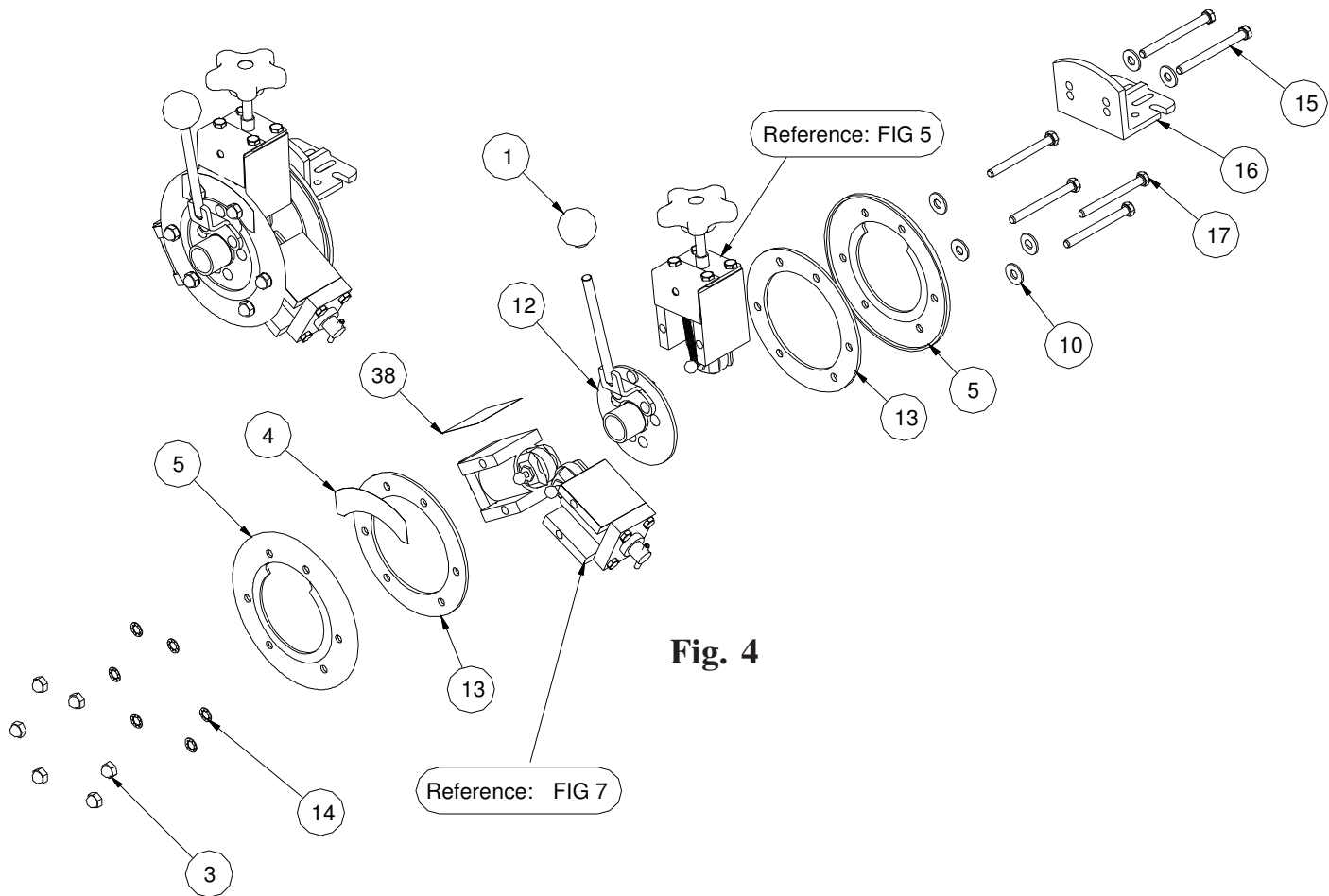
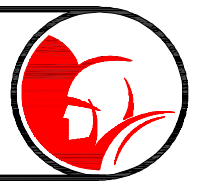
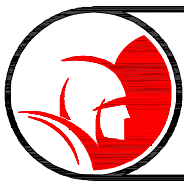

Fig. 4

ITEM	QTY	PART NUMBER	DESCRIPTION
1	1	02856900	KNOB
3	6	04134900	NUT ACORN CAP 5/16-18
4	1	04220000	DECAL BRG PLATE MOD 75 FEED
5	2	04218600	PLATE BRG MOD 75 FEED
10	6	00162600	WASHER, FLAT 5/16 USS
12	1	44223900	2001 ACTURATOR ASSY
13	2	04218300	PLATE STATIONARY 75 FEED
14	6	00167100	INTERNAL TOOTH LOCKWASHER
15	2	00169500	SCREW, HEX HD CAP 5/16-18x3-1/2
16	1	44249900	UNIVERSAL MOUNTING PLATE
17	4	00480300	SCREW, HEX HD CAP 5/16-18x3-1/4
38	2	44220100	DIAL A CABLE LABEL
FIG 5	1	04224000	BEARING BLOCK ASSY - LONG
FIG 7	2	44219900	BEARING BLOCK ASSY - SHORT



04224000



Bearing Block Assy (Long)

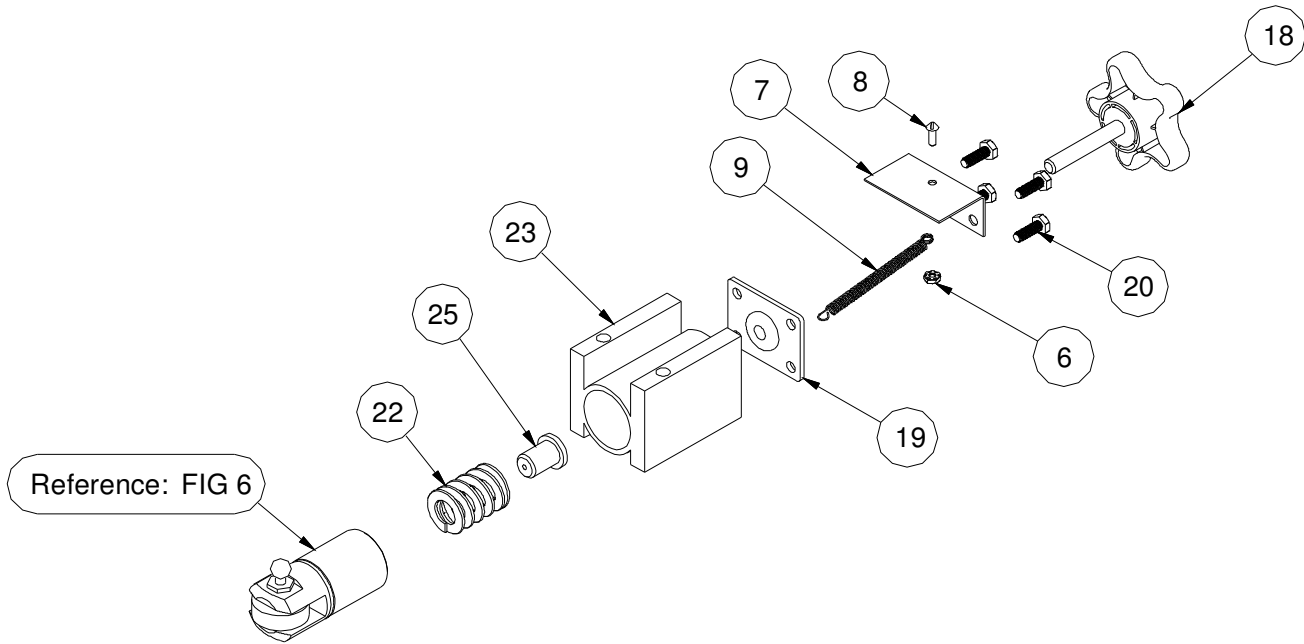
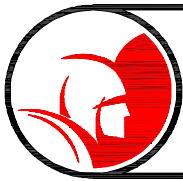

Fig. 5

ITEM	QTY	PART NUMBER	DESCRIPTION
6	1	03312001	Nut Kep #8-32 Zinc Plated
7	1	44221900	2001 Cover Spring
8	1	01921801	Screw, Mach Rd Hd SI 8-32 x 1/2
9	1	44230100	2001 Spring Feed Ext
18	1	03415800	Knob and Screw Assy
19	1	04219000	Cap End Weld Assy 75
20	4	00113700	Screw, Hex Hd 1/4-20 X 3/4
22	1	04220100	Spring Hvy Duty Mod 75 Feed
23	1	04217900	Block Bearing Long Mod 75 Feed
25	1	03415700	Bushing & Ball Assembly
FIG 6	1	44119600	Wheel Carrier Body Comp (Long)



44219900 Bearing Block Assy (Short)

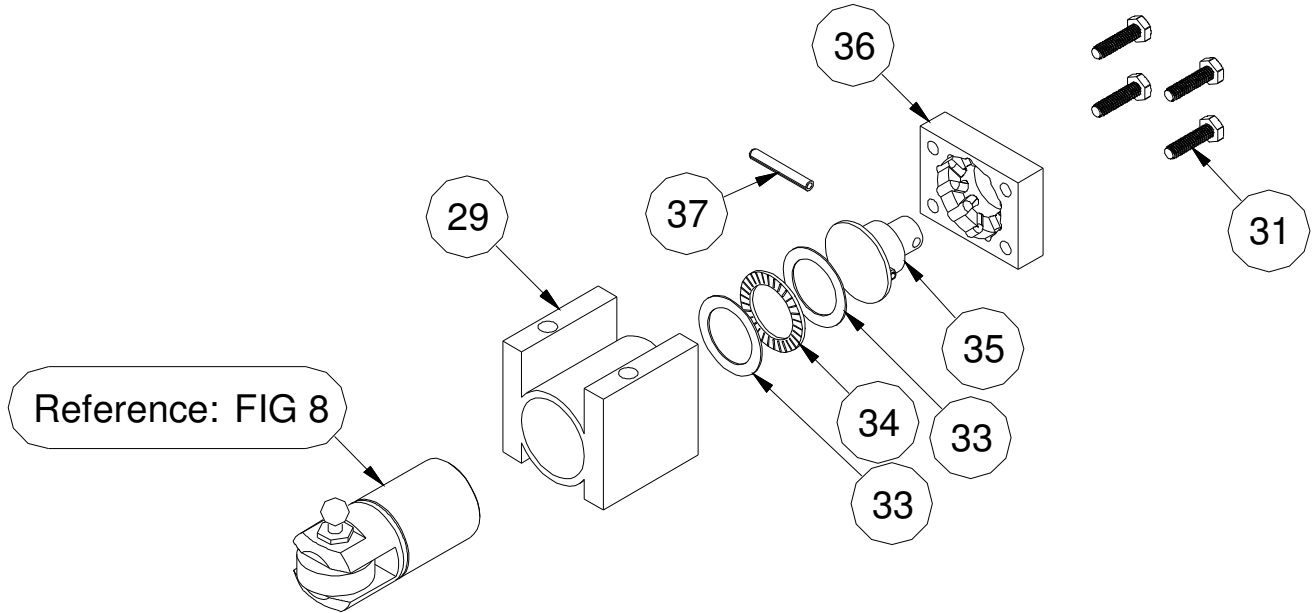

Fig. 7

PART			
ITEM	QTY	NUMBER	DESCRIPTION
29	1	04217800	Block Bearing Short Mod 75 Feed
31	4	00113901	Screw, Hex Hd 1/4-20 x 1
33	2	04219600	Thrust Race
34	1	04219500	Thrust Bearing
35	1	44222100	2001 Knob
36	1	44213800	Dial A Cable Block
37	1	44222200	Roll Pin 2001
FIG 8	1	44119700	Wheel Carrier Body Comp (Short)



44119600

Wheel Carrier Body Comp (Long)

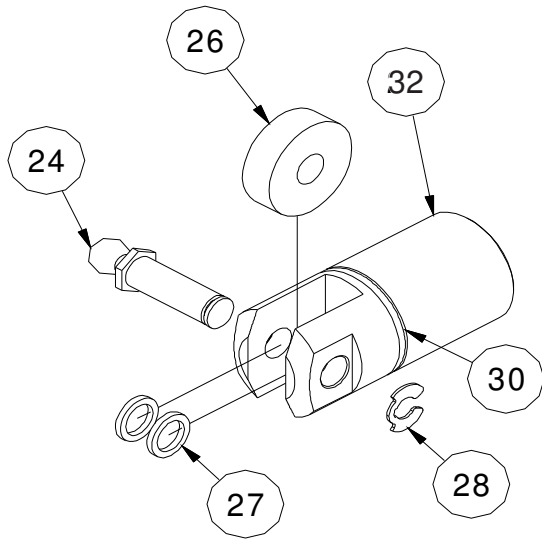

ITEM	QTY	PART NUMBER	DESCRIPTION
24	1	04217700	Pin Drive Mod 75 Feed
26	1	04219700	Bearing Drive Mod 75 Feed
27	2	04219800	Washer 75 Feed Stainless
28	1	04219900	Ring Retaining-External
30	1	44250200	O-Ring Seal, Wheel Carrier
32	1	04218400	Body Wheel Carrier w/ Hole Long (Includes item 30)

Fig. 6



44119700

Wheel Carrier Body Comp (Short)

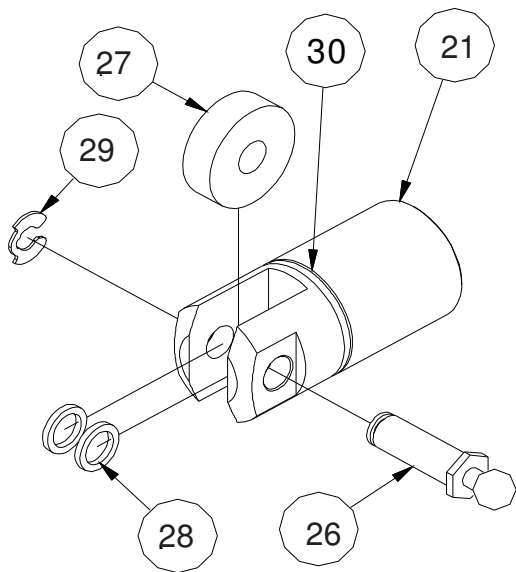

ITEM	QTY	PART NUMBER	DESCRIPTION
21	1	04218500	Body Wheel Carrier w/ Hole Long (includes item 30)
26	1	04217700	Pin Drive Mod 75 Feed
27	1	04219700	Bearing Drive Mod 75 Feed
28	2	04219800	Washer 75 Feed Stainless
29	1	04219900	Ring Retaining-External
30	1	44250200	O-Ring Seal, Wheel Carrier

Fig. 8



Installation Instructions for Model 1065 & 2001



(See: Fig. 4 and Fig 5)

The following instructions are for manual machines, delete step 1 through 4 when replacing older power feed units.

1. Remove set collar on distributor arm and remove bearing assembly by removing screw in bottom.
2. Install new thrust bearing (inner race facing forward) on distributor arm.
3. Install new bearing assembly on distributor arm with swing bolts forward. Replace bottom screw and lockwasher, push bearing assembly back against thrust bearing and tighten lower screw.
4. Replace set collar and tighten.

ATTENTION Model 1061 users only: Replace upper front casting assembly with 03414700.

5. Set Dial-A-Cable adjusters for 3/4" cable size (full open) and turn knob #18 counter clockwise (left) to raise upper wheel carrier. Place actuator handle #12 to "N" neutral position.
6. Place cable through back of power feed while sliding power feed unit over cable into proper position on new bearing assembly. Bring swing bolts up into slots on universal mounting plate #16 and tighten hand tight.
7. Position cable forward to the point where the smallest diameter of cable will come in contact with the drive bearings, adjust your Dial-A-Cable for your cable size. Turn knob #18 clockwise (right) until contact is made with drive bearing.
8. Apply grease through grease fitting on bearing assembly. Installation is complete. Refer to operating instructions for safe operation.

Special Note: 2001 Dial-A-Cable Power Feed Replacement. When Replacing Dial-A-Cable power feed unit on 2001 machines, the two (2) long screws #15 must be used for old unit.



Installation Instructions For Model 300



(See: Fig. 4, Fig. 5 & Fig 14)

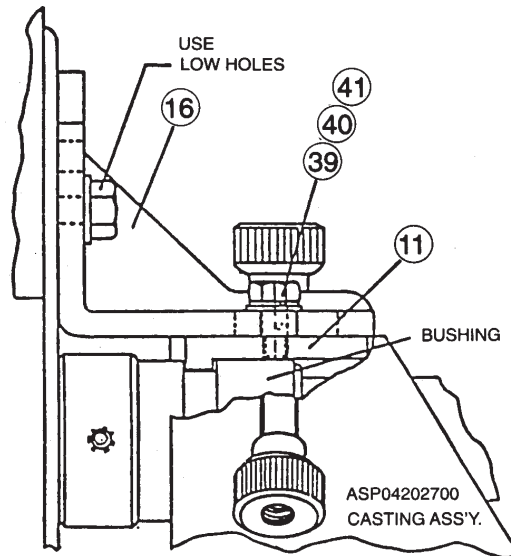

Fig. 9

The following instructions are for manual machines, delete step 1 through 3 when replacing older power feed units.

1. Remove upper front casting assembly.
2. Install new upper front casting assembly (04202700).
3. Install busing lock (#11) to mounting plate (#16) on drive unit. Use items #39, 40, and 41. Position as per Fig. 5. Place screws in bushing lock **finger tight only**.
4. Set Dial-A-Cable adjusters for 3/4" cable size (full open) and turn knob (#18) counter clockwise (left) to raise upper wheel carrier. Place actuator handle (#12) to "N" neutral position.
5. Place cable through back of power feed while sliding power feed unit over cable into proper position on upper front casting assembly. Make certain lip of bushing lock engages slot in distributor arm bushing (Fig. 9). Swing up clamps on upper front casting into slots provided on mounting plate lock down tight. Now, tighten bushing lock screws.
6. Position cable forward to the point where the smallest diameter of cable will come in contact with the drive bearings, adjust your Dial-A-Cable for your cable size. Turn knob (#18) clockwise (right) until contact is made with drive bearing.
7. Installation is complete. Refer to operating instructions for safe operation.



Installation Instructions For Model 100



(See: Fig. 4 and Fig. 5)

The following instructions are for manual machines, delete step 1 through 3 when replacing older power feed units.

1. Remove mounting plate (#16) from Dial-A-Cable power feed and reposition bolts in upper holes in (#16) plate.
2. Remove thumb screws and latch assembly from trunnion on machine.
3. Position drum into place on power drive unit.
4. Set Dial-A-Cable adjusters for 3/4" cable size (full open) and turn knob (#18) counter clockwise (left) to raise upper wheel carrier. Place actuator handle (#12) to "N" neutral position.
5. Slide Dial-A-Cable power feed unit over cable end. Position mounting plate on trunnion using the two (2) round holes and locking in place with the two (2) thumb screws removed in step 2. Tighten securely.
6. Position the cable forward to the point where the smallest diameter of cable will come in contact with the drive bearings, adjust your Dial-A-Cable for your cable size. Turn knob (#18) clockwise (right) until contact is made with drive bearing.
7. Installation is complete. Refer to operating instructions for safe operation.

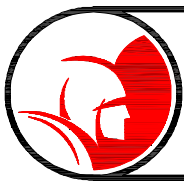

Operating Instructions For Model 75 Dial-A-Cable Power Feed



(See: Fig. 4, Fig. 5, Fig. 7 & Fig. 8)

WARNING!



Follow all safety instructions as outlined in your operator's manual supplied with your machine. If a new operator manual is required, contact Spartan Tool (800-435-3866) or download it at www.spartantool.com.

The following instructions refer to the use of the Spartan cable safety guide (44225300) (Fig. 1) which we recommend for safer operation. Always wear Spartan riveted gloves when operating machines.

Upon completion of installation instructions for your machine and before actual sewer cleaning, it is recommended you become familiar with your power feed operation. By moving the actuator assembly (#12) by use of the knob (#1) you will note the wheel carrier blocks (#21) and (#32) will turn. When the drum and cable are rotating the movement will feed the cable in and out by the slanting of the drive bearings (#26). The decal (#4) on the front bearing plate (#5) is marked from left to right "R" (reverse), "N" (neutral), and "F" (forward).

1. Place the actuator handle to the midway point between "N" and "F" on the name plate.
2. No cutter should be attached to the cable at this time.
3. The forward/reverse electrical switch should be placed in the forward "F" with the machine plugged in to a power supply. **Note:** If drum rotation is reversed, feed of cable will be reversed.
4. Momentarily step on foot switch and check machine rotation. Drum and cable should rotate left or counter clockwise from cable end of machine.

WARNING!



Use care when performing the next operation as cable will be fed out and if allowed to feed too long may whip. Do not feed cable out more than 12 inches from feed unit.

5. With left hand on actuator assembly knob and right hand on adjusting knob #18, step on footswitch and slowly tighten (turn clockwise) knob #18. When cable is driving steadily forward, stop turning knob. Move actuator assembly knob to "R" position on name plate and cable should now retrieve. Cable movement will stop feeding in or out when actuator assembly knob is placed in the "N" position. You will note the farther the actuator assembly knob is moved to the forward or reverse position, the faster the cable will move out or in.

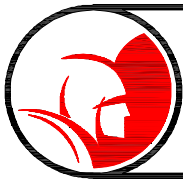

Cleaning Operation



WARNING!



Make sure to keep downward pressure on the cable safety guide at all times since flexible cable is subject to buckling under high torque conditions.

If cable slips or whenever a stoppage is encountered, knob #18 may be tightened down until cable is moving steadily. Caution! Do not tighten knob anymore than is necessary to cause cable to move in a steady motion in or out. Excessive tightening may damage cable or feed unit or overload motor. If at any time when cable is feeding into sewer line and torque build-up occurs, immediately move actuator control handle to the “R” (reverse) position to pull cable back. As soon as torque is relieved, move handle again to the “F” (forward) position. Repeat until stoppage is cleared.

Note: The electrical switch is to be placed in the reverse position for a few seconds only to release an entangled blade or to negotiate a difficult turn or trap. Never continue operating the machine in the reverse position. The cable may exit the drum prematurely causing injury.



How To Disassemble and Reassemble Model 75 Power Feed Unit



1. Remove top two (2) acorn nuts #3 from screws #15 that holds feed unit to mounting plate #16. (On 2001 unit, remove two (2) #15 screws at bottom that holds feed unit to upper front casting).
2. Remove feed unit from mounting screw #15 by pulling forward.
3. Lay unit flat on back.
4. Remove remaining acorn nuts #3.
5. Remove bearing plate #5 (with decal).
6. Remove handle assembly #12.
7. Remove stationary plate #13.
8. Remove the two (2) short bearing blocks #29 as assemblies.
9. Remove the long bearing block #23 as an assembly.
10. Remove bottom stationary plate #13.
11. Remove back bearing plate #35 (without decal).

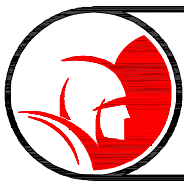

Disassembly of Short Bearing Blocks



(See: Fig.10 and Fig. 11)

1. Pull wheel carrier bodies #21 from blocks #29.
2. Remove the two (2) thrust races #33 and one (1) thrust bearing #34 from each unit.
3. Remove four screws #31 holding Dial-A-Cable assembly #35, 36, and 37 to bearing block #29.
(Do not disassemble unit)
4. Remove retaining rings #28 from drive pins #24 and pull pins from carrier bodies #21. This will release the drive roller #26 and two (2) spacers #27. Remove "O" ring #30 from carrier body grooves, use care not to damage same.

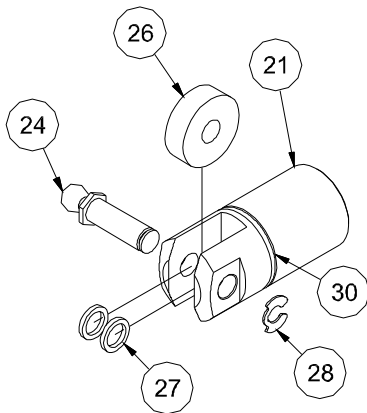

Fig. 10

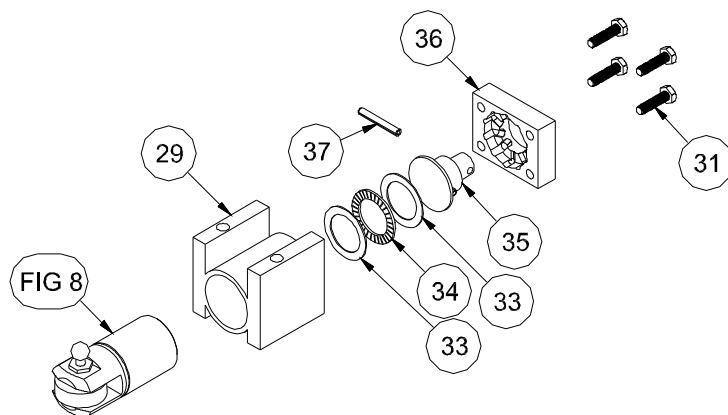
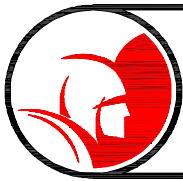

Fig. 11



Disassembly of Long Bearing Blocks



(See: Fig.12 and Fig. 13)

1. Remove the two (2) screws #20 holding spring cover #7 to top of long bearing block #23. Leave remaining two (2) screws.
2. Pull wheel carrier body #32 from block #23 with cove #7 and spring #9 attached.
3. Remove spring #22 and ball and bushing assembly #25 from long wheel carrier body.
4. Remove retaining ring #28 from drive pin #24 and pull pin from carrier body #32 with feed spring and cover attached. This will release the drive roller #26 and two (2) spacers #27. Remove "O" ring #30 from carrier body groove, use care not to damage same.
5. Unscrew knob #18 and remove two (2) remaining screws #20 from end cap #19.

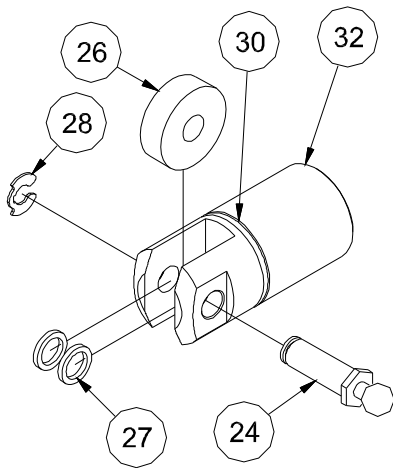

Fig. 12

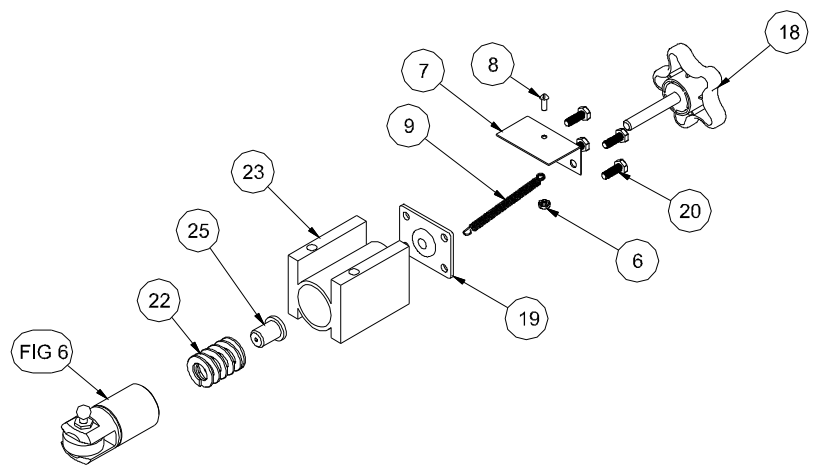

Fig. 13



Cleaning and Lubricating Instructions



WARNING!



The cleaning of parts in this instruction section recommends the use of kerosene for parts cleaning which is combustible and care should be used. Always work in a well ventilated area away from fire or open flame. When parts cleaning, always wear eye protection, rubber gloves and plastic or rubber apron. When cleaning of parts is complete dispose of all cleaning rags and waste cleaner in proper manner. NEVER USE GASOLINE OR ANY OTHER HIGHLY COMBUSTIBLE SUBSTANCE FOR CLEANING PARTS.

After unit disassembly, all parts with the exception of the drive rollers #26 and “O” rings #20 should be soaked and cleaned in kerosene to remove grease and grime. Wipe parts and allow to dry completely before lubricating in assembly. Drive rollers #26 and “O” rings #30 should be wiped clean only and not placed in cleaner. Rollers are prelubricated and sealed if drive bearings are rough turning or frozen and don't turn, replace with new parts. We recommend the purchase of three (3) extra drive bearings #26 and three (3) extra “O” rings for replacement when necessary.

Lubrication of drive parts should be done as parts are reassembled. We recommend using a multipurpose lithium grease NLGI #2 which is water resistant and is available in tubes and aerosol cans.



Re-Assembly of Short Bearing Blocks



1. Replace “O” rings #30 into groove in short wheel carrier block #21. (Spring bottom on block)
2. Place drive wheels #26 in short blocks. BE SURE SPACERS #27 ARE ON EACH SIDE OF WHEEL. Slip drive pin #24 through hole and replace retaining ring #28.
3. Lubricate inside cylindrical section of short bearing blocks #29, covering inside wall with thin film of grease.
4. Lubricate “O” rings and lower section of wheel carrier blocks #21 and slide wheel carrier assembly into blank untreaded end of short bearing blocks until drive wheel cut-out is flush with top of bearing block allowing room for thrust bearing.
5. Turn assembly over and place one (1) race #33 on bottom. Lubricate thrust bearing #34 and place on top of race. Place second race on top of thrust bearing.
6. Place Dial-A-Cable block assembly #36 on bottom of short bearing block. Insert four (4) long hex screws #31 through holes and screw into block, tighten hex screws securely. Assembly is complete.

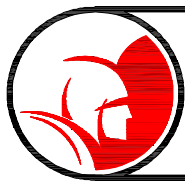

Re-Assembly - Long Bearing Blocks



1. Replace "O" rings #30 into groove in long wheel carrier block #32. (Spring hole in bottom)
2. Lubricate inside cylindrical section of long bearing block #23. Install end cap #19 on end of long bearing block with two (2) short screws #20. Place these screws in the short rib side of the bearing block.
3. Lubricate "O" ring #30 and lower section of wheel carrier block #32. Install spring #22 into spring hole and install bushing and ball assembly #25 into spring. Slide wheel carrier unit into bottom of long bearing block.
4. Lay bearing block on bench with short rib side down. Place drive wheel #26 into end of wheel carrier block. BE SURE SPACERS #27 ARE ON EACH SIDE OF WHEEL.
5. Place drive Pin #24 (which has spring and cover attached) through hole and replace retaining ring #28.
6. Drive pin #24 should now be centered between the two (2) long ribs on the bearing block to allow spring #9 to lay between ribs.
7. Pull cover #7 up and place over end cap #19 attach with remaining two (2) short screws. Tighten all screws securely.
8. Replace knob #18 in end cap #19.

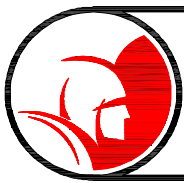

Cable Safety Guide Instructions



The Spartan Tool Cable Safety Guide has been designed to improve the operational safety. Its purpose is to prevent direct contact with the rotating cable. To install, place the spring end of the Cable Safety Guide against the hub of the power feed and rotate it counterclockwise under pressure until the spring rests against the wall of the Actuator Assembly.

Figure 1 illustrates the proper positioning and appropriate safety gear when using the machine and Cable Safety Guide:

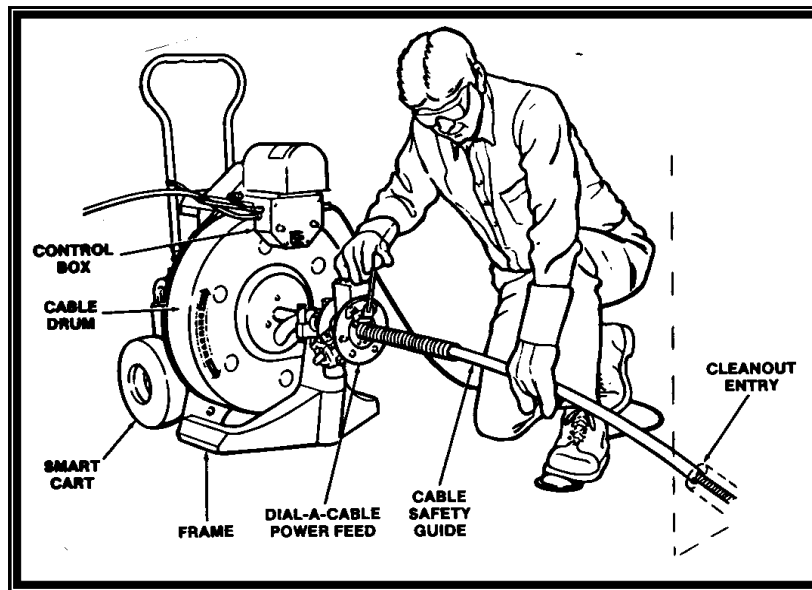

Figure 1



WARNING



Read the appropriate "Operating & Safety Instructions" before operating any Spartan Tool machine. Sewer cleaning can be dangerous if precautions are not taken and rules are not followed.

Before using the machine, make sure the operator's switch is in the "forward" position. [The drum will rotate clockwise when standing behind the machine.]



WARNING



If the operator's switch is in the "Reverse" position, the power feed will operate counter to the labeling on the power feed - "Reverse" will move the cable forward and "Forward" will retrieve the cable.



Cable Safety Guide Instructions (cont)



The length of the Cable Safety Guide is the correct distance the machine should be located from the pipe opening. If the machine cannot be located as prescribed, precautions must be taken. A pipe section must be placed in the area between the "cleanout entry" and the end of the Cable Safety Guide to avoid injury.

WARNING



A distance exceeding of 3' between the machine and the pipe opening may cause personal injury from a rotating, swinging cable, if precautions are not taken.



If a "cleanout" is positioned on a wall, then the machine should have support legs, found in the tool box, positioned as in Figure 2. Ensure the appropriate pipe section is placed between the Cable Safety Guide and the Cleanout Entry to avoid injury.

WARNING



Make sure to keep downward pressure on the Cable Safety Guide to keep slack from developing on the cable to prevent looping.

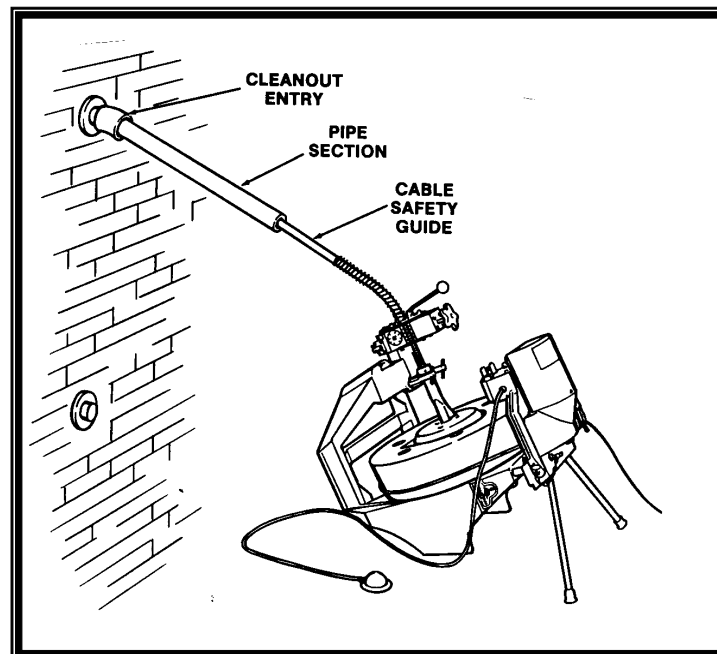

Figure 2



Warranty Information



ONE YEAR WARRANTY

Spartan Tool warrants its equipment to be free from defects in material and workmanship for one year from the date of purchase. To obtain warranty service, a purchaser should notify Spartan Tool in writing, at the address provided below, within the warranty period, and Spartan Tool will direct where to take or send the equipment for service. If the defect is covered by the warranty, Spartan Tool will repair or replace, at its option, the defective equipment, without charge for labor or materials. (Freight and insurance are the purchaser's responsibility.)

This warranty is limited to the original retail purchaser and is not transferable. Spartan Tool assumes no responsibility for damage due to accident, neglect, abuse, tampering or misuse, nor damage from repairs or alterations by others. This warranty does not cover damage to the equipment resulting from the use of replacement parts other than Spartan Tool parts.

Spartan Tool's sole obligation and the original retail purchaser's exclusive remedy under this warranty shall be for repair or replacement as described above. ALL OTHER WARRANTIES, WHETHER EXPRESSED OR IMPLIED, INCLUDING BUT NOT LIMITED TO IMPLIED WARRANTIES OF MERCHANTABILITY AND FITNESS FOR A PARTICULAR PURPOSE ARE DISCLAIMED. IN NO EVENT SHALL SPARTAN TOOL BE LIABLE FOR ANY INCIDENTAL OR CONSEQUENTIAL DAMAGES.

SPARTAN TOOL L.L.C.
MENDOTA, ILLINOIS 61342

Spartan Tool, L.L.C. reserves the right to make changes at any time, without notice, to specifications and models and also discontinue models. The right is also reserved to change specifications or parts at any time without incurring any obligation to equip same on models manufactured prior to the date of change.

SPARTAN TOOL L.L.C.
1506 W. Division Street
Mendota, IL 61342
(800)435-3866 ♦ Fax (888)876-2371
www.spartantool.com