

TOMAHAWK

3500 WATT INVERTER GENERATOR
TG3500I

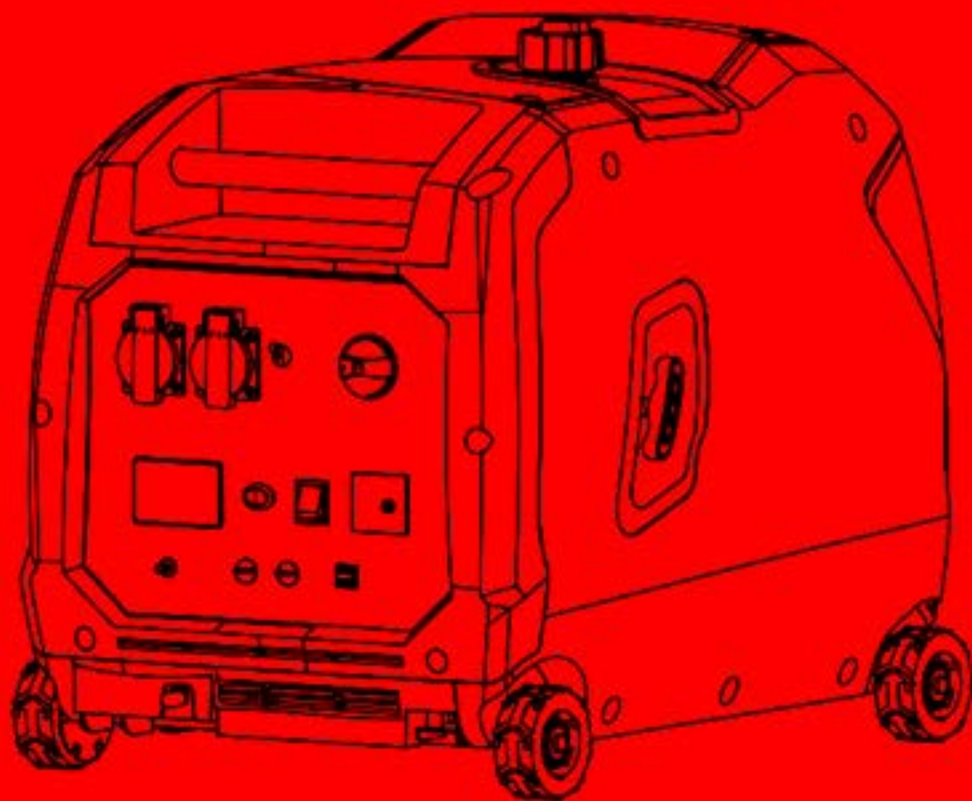

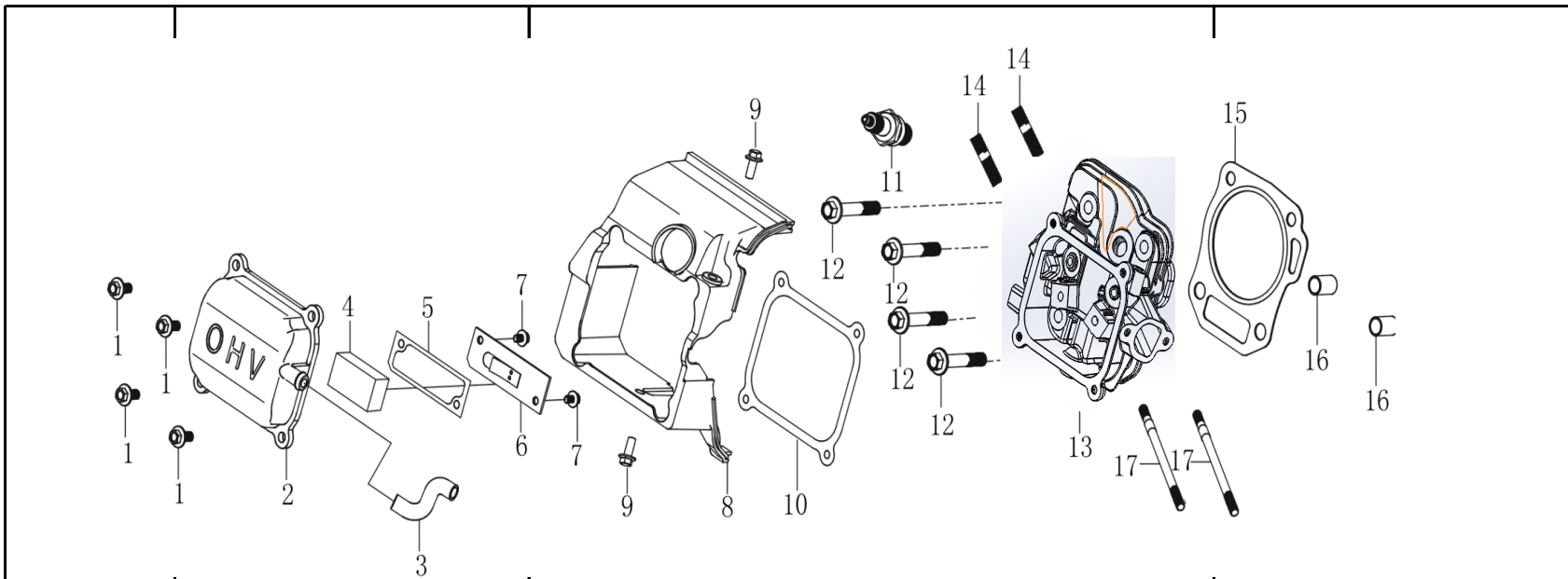

(CYLINDER HEAD)

Ser.No	Part No.	Description	Quantity
1	5787.06020.00.01	BOLT ,FLANGE M6X20	4
2	T70.0001.001.00.01	COVER , HEAD	1
3	T70.2370.001.00.00	TUBE , BREATHER	1
4	165.7080.001.00.00	FILTER, HEAD COVER	1
5	T70.7061.001.00.01	GASKET, CAP, BREATHER	1
6	T70.7061.001.00.00	CAP, BREATHER CHAMBER	1
7	5789.05012.00.01	BOLT ,FLANGE M5X12	2
8	T70.2190.001.00.00	SHROUD COMP	1
9	5787.06012.00.01	BOLT , FLANGE , 6X12	2
10	T70.3000.001.00.00	PACKING , HEAD COVER	1
11	168.2160.004.00.00	PLUG , SPARK	1
12	5789.08060.00.01	BOLT , FLANGE , M8X60	4
13	T70.0010.C01.00.00	HEAD COMP ,CYLINDER	1
14	0900.08035.00.01	BOLT , STUD , EX. M8X35	2
15	T70.3020.001.00.00	GASKET , CYLINDER	1
16	168.3170.002.00.00	PIN,DOWEL10*14	2
17	0900.06095.00.01	BOLT,STUD,IN M6X95	2

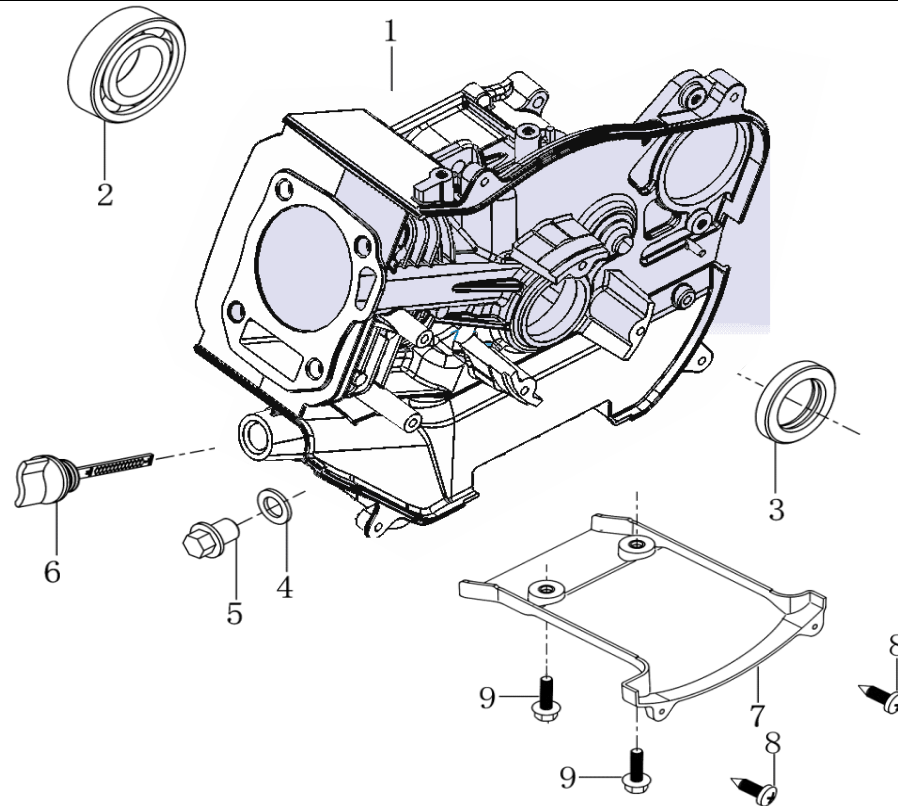

(CRANKCASE)

Ser.No	Part No.	Description	Quantity
1	T70.1000.001.00.00	CRANK CASE	1
2	168.0270.002.00.00	BEARING 6205	1
3	168.3150.001.00.00	OIL SEAL 25x41.25x6	1
4	168.1260.001.66.00	WASHER,DRAIN PLUG 10x16x1.5	1
5	168.1250.001.00.20	BOLT ,DRAIN PLUG M10x1.25x15	1
6	T70.1230.001.16.00	CAP ASSY.	1
7	T70.2230.001.00.00	WIND GUIDE	1
8	0845.42013.00.01	SELT THREADING SCREW	2
9	5789.05012.00.01	SCREW,PAN	2

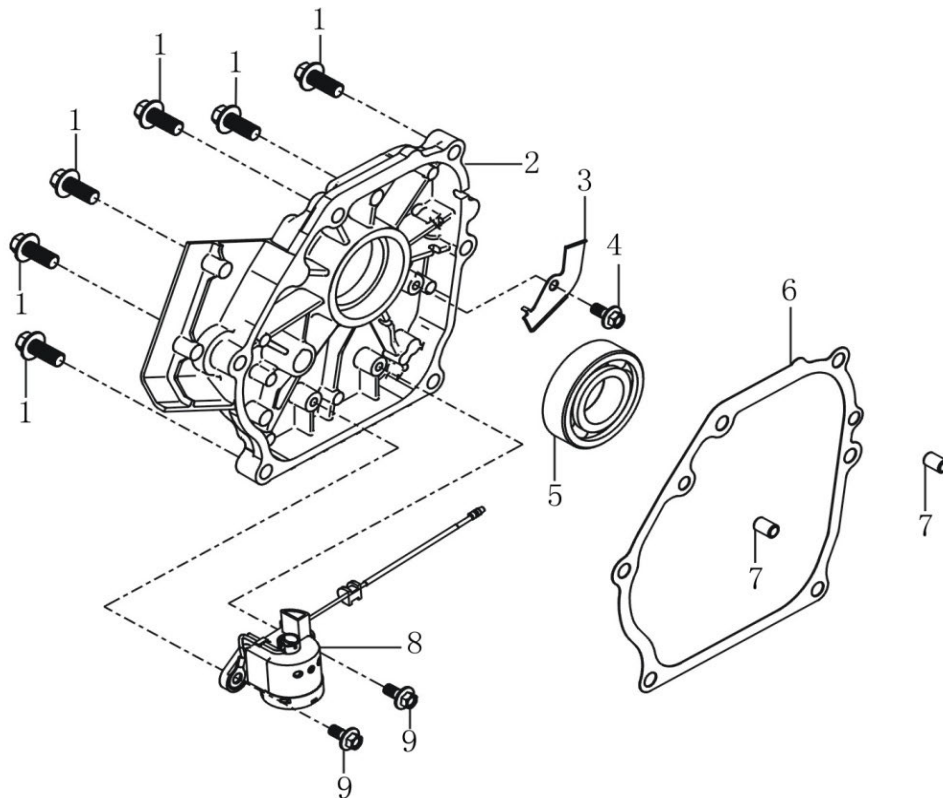

(CRANKCASE COVER)

Ser.No	Part No.	Description	Quantity
1	5787.08030.00.01	BOLT ,FLANGE M8x30	6
2	T70.1010.001.00.00	COVER ,CRANKCASE	1
3	T70.2090.001.00.00	PLATE	1
4	5787.06012.00.01	BOLT , FLANGE M6x12	1
5	168.0270.002.00.00	BEARING 6205	1
6	T70.3040.001.00.00	PACKING ,CASE COVER	1
7	168.3170.001.00.00	PIN ,DOWEL 8x14	2
8	148.1020.001.00.00	OIL LEVEL SWITCH	1
9	5787.06014.00.01	BOLT , FLANGE M6x14	2

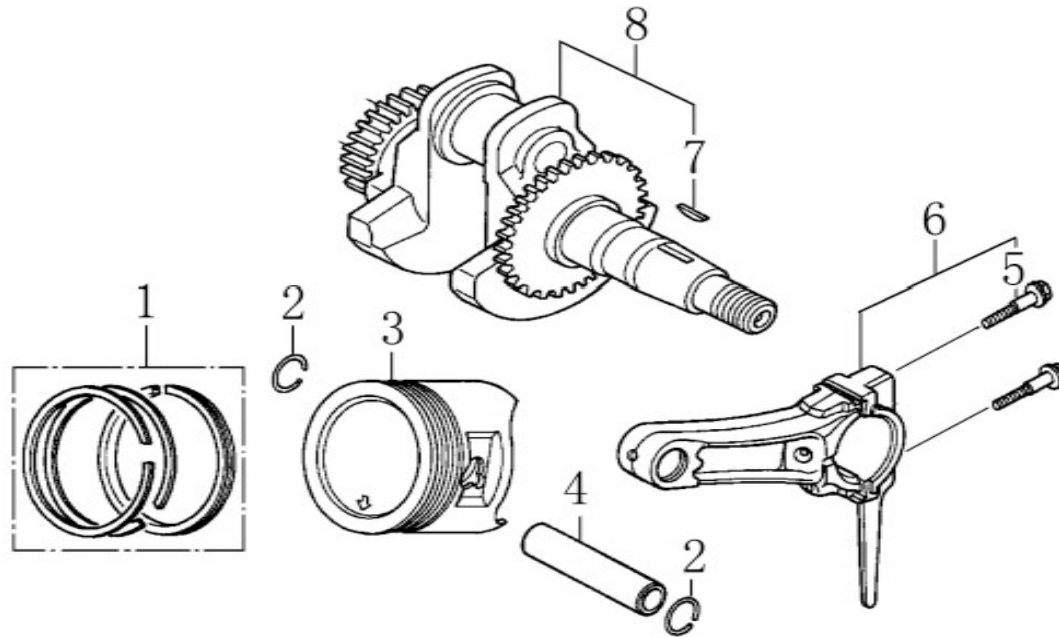

(CRANKSHAFT/PISTON)

Ser.No	Part No.	Description	Quantity
1	T70.0210.001.00.00	RING SET	1
2	168.0230.001.00.00	CLIP , PISTON PIN	2
3	T70.0200.001.00.00	PISTON	1
4	168.0220.001.00.00	PIN , PISTON	1
5	168.0190.001.00.01	BOLT,CONNECTING ROD	2
6	168.0190.001.00.00	ROD ASSY., CONNECTING	1
7	T70.0180.001.60.01	KEY	1
8	T70.0180.001.60.00	CRANKSHAFT COMP	1

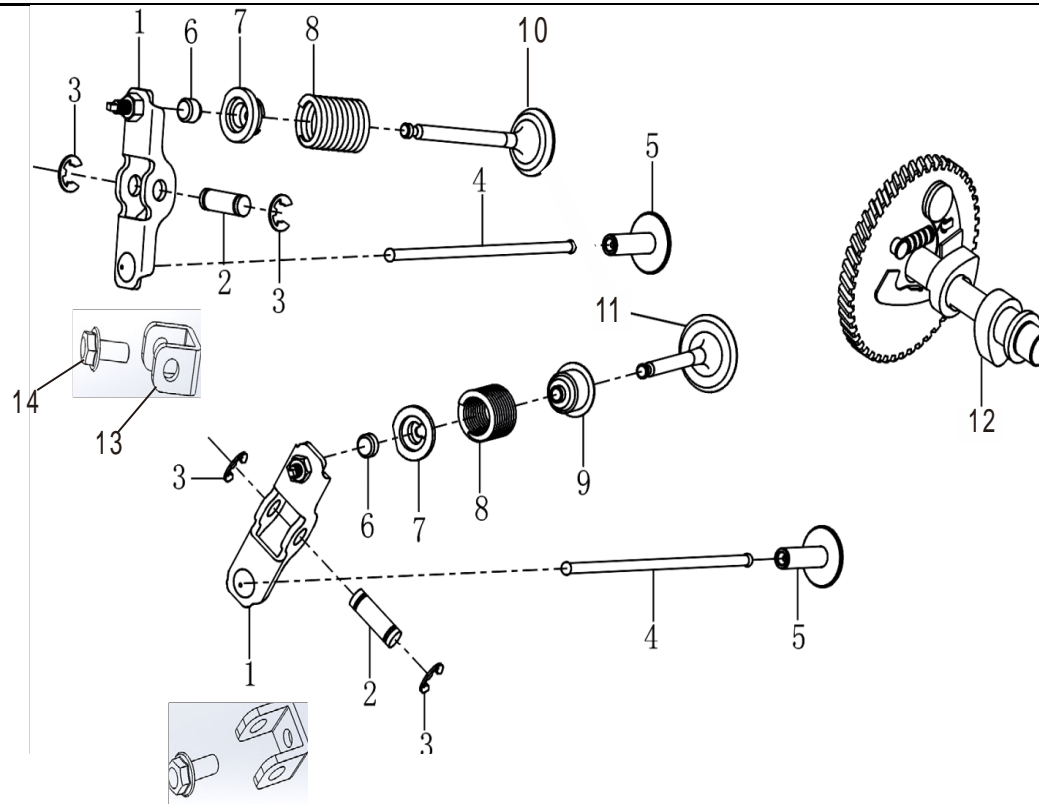

(ROCKER,CAMSHAFT)

Ser.No	Part No.	Description	Quantity
1	165.0100.001.00.00	ARM COMP.	2
2	165.0100.001.00.01	VALVE ROCKER SHAFT	2
3	487.1176.001.00.00	LOCKER	4
4	165.0160.001.00.00	ROD,PUSH	2
5	F68.1030.001.00.00	LIFTER VALVE	2
6	168.0090.001.00.00	Cap,Exhaust valve	2
7	168.0070.001.00.00	RETAINER,VALVE SPRING	2
8	165.0040.001.00.00	SPRING , VALVE	2
9	165.0085.001.00.00	SEAL,GUIDE	1
10	T70.0030.001.00.00	Exhaust valve	1
11	T70.0020.001.00.00	Intake valve	1
12	F68.1040.001.60.00	CAMSHAFT ASSY.	1
13	165.0100.001.00.02	Rocker arm bracket	2
14	5787.06012.00.01	BOLT ,FLANGE M6x20	2

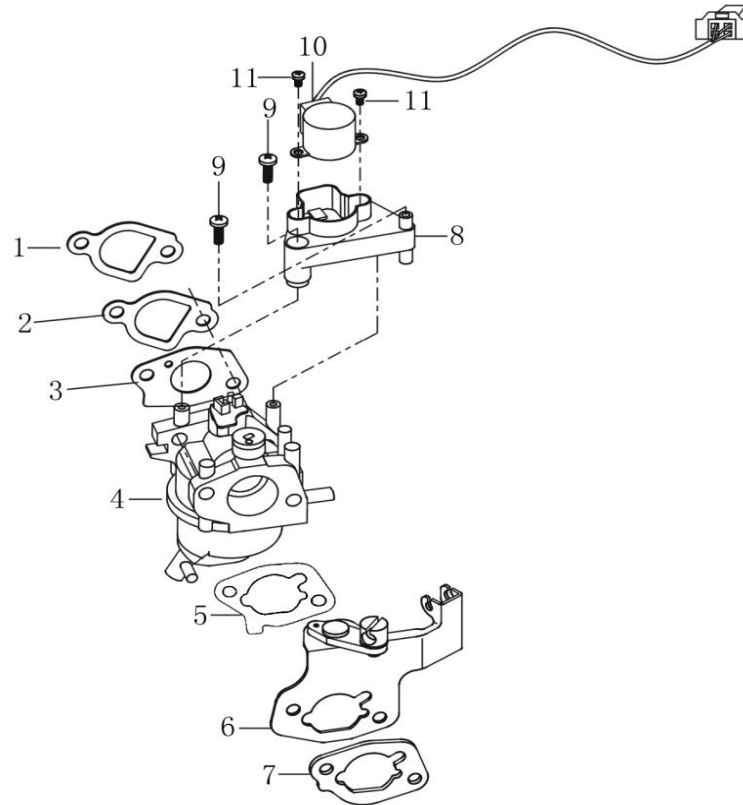

(CARBURETOR)

Ser.No	Part No.	Description	Quantity
1	T70.3060.001.00.00	Inlet gasket	1
2	T70.2300.001.00.00	Carburetor block	1
3	T70.3080.001.00.00	PACKING ., CARBURETOR	1
4	T70.2260.001.00.00	CARBURETOR	1
5	T70.3101.001.00.00	Damper bracket gasket	1
6	T70.3219.001.00.00	BRACKET CHOKE	1
7	T70.3090.001.00.00	Air filter gasket	1
8	487.1531.001.00.00	BRACKET, ELETROMOTOR	1
9	0818.04010.00.01	SCREW , TAPPING , M4*10	2
10	T70.4000.001.00.00	SPEED VARIABLE STEPPER MOTOR	1
11	0818.04008.10.01	SCREW, M4*5(S=6)	2

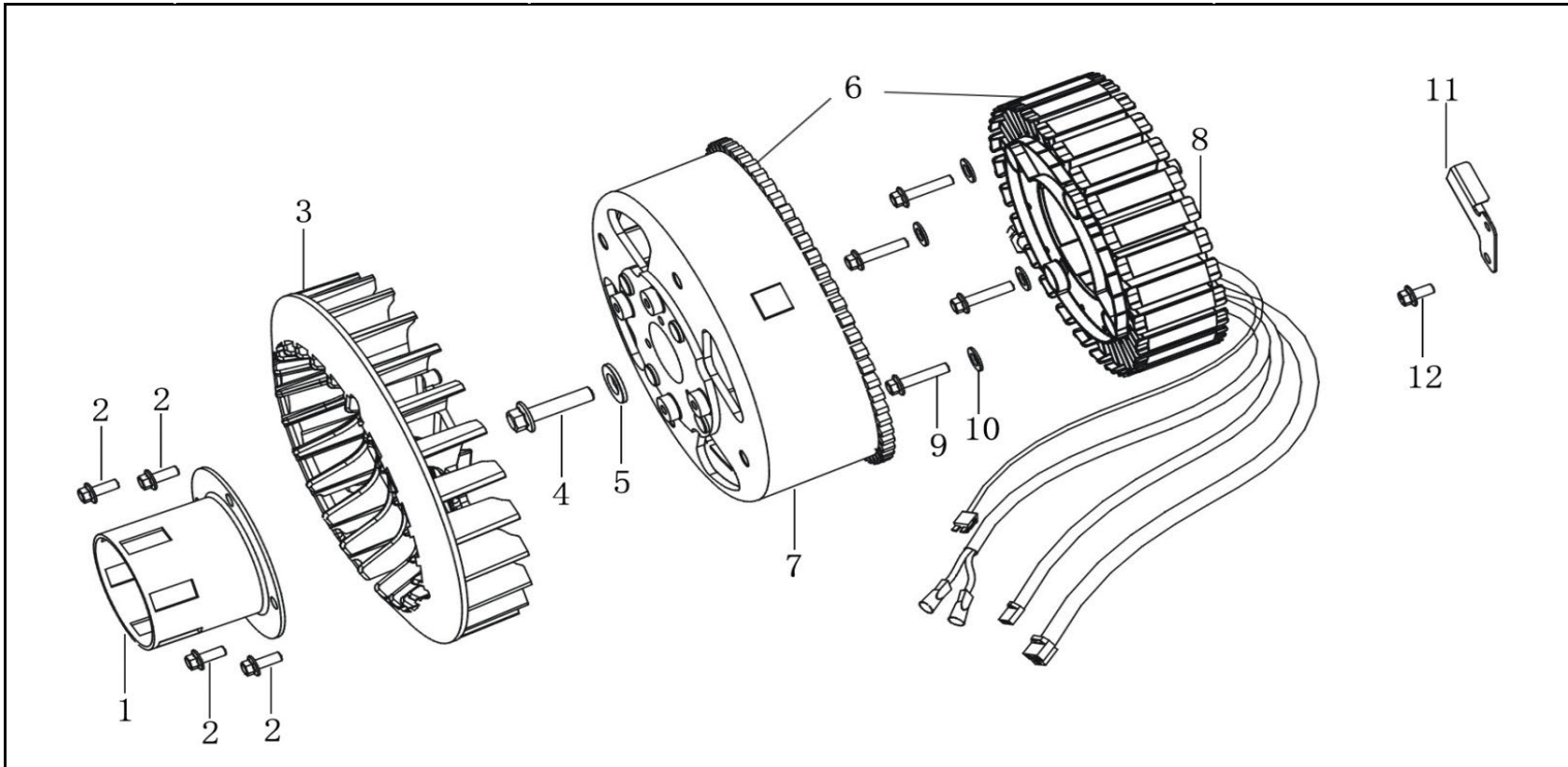

(ROTOR.STATOR)

Ser.No	Part No.	Description	Quantity
1	T70.2020.001.00.00	PULLEY, STARTER	1
2	5787.06014.00.01	BOLT,FLANGE M6×14	4
3	T70.2030.001.63.00	MOTOR FAN	1
4	5787.08030.00.01	BOLT,FLANGE M8×30	1
5	T70.4100.001.00.00	WASHER 8*34*4	1
6	487.4000.005.00.00	ALTERNATOR ASSY.	1
7	487.4000.005.00.01	MOTOR ROTOR	1
8	487.4000.005.00.02	MOTOR STATOR	1
9	0070.06050.00.04	INNER SIX ANGLE SCREW	3
10	0093.06000.00.01	WASHER,SPRING	3
11	T70.2090.002.00.00	PRESSING LINE PLATE	1
12	5787.06012.00.01	BOLT, FLANGE 6*12	1

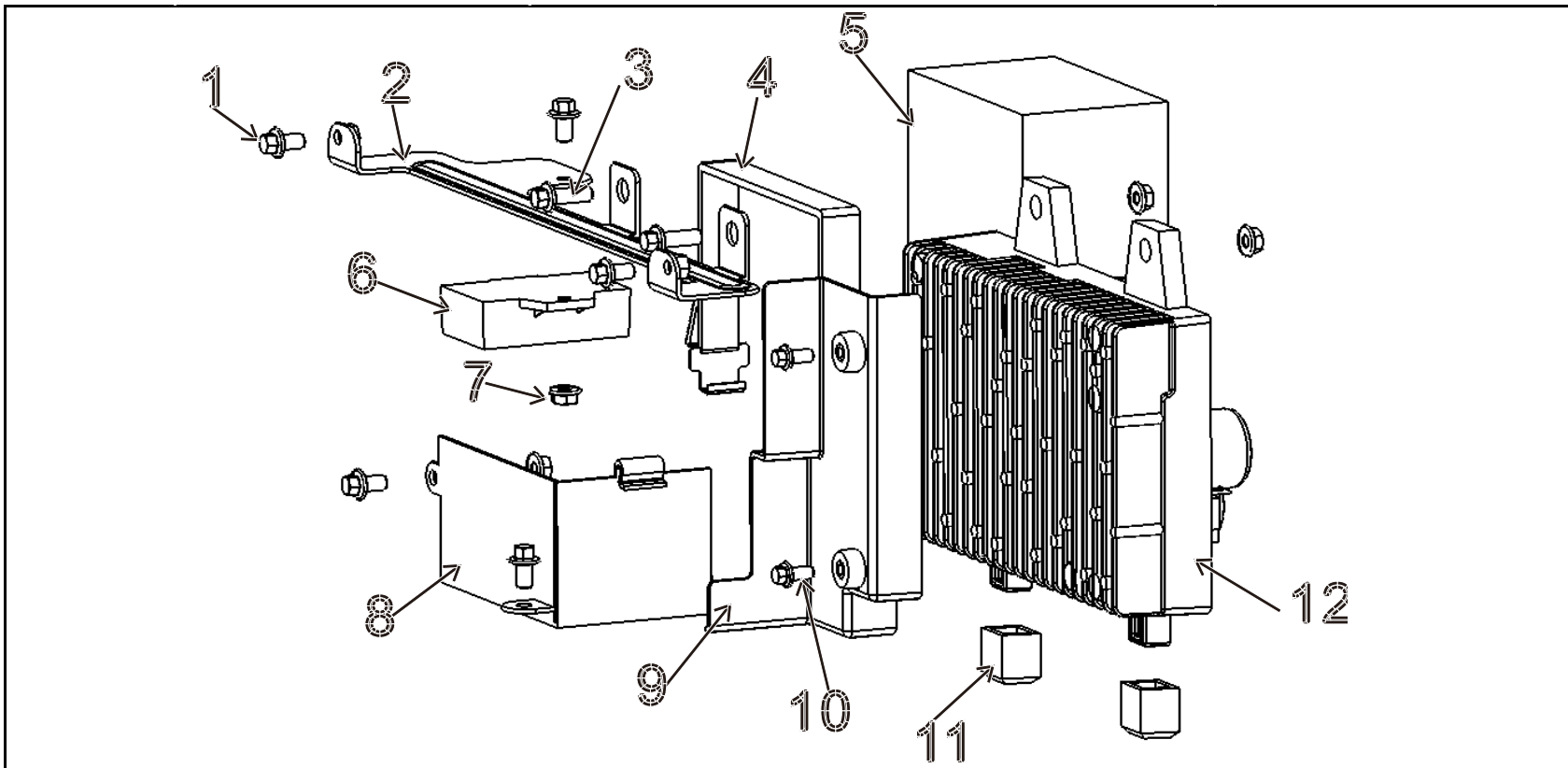

(INVERTER ASSY)

Ser.No	Part No.	Description	Quantity
1	5787.06012.00.01	BOLT ,FLANGE M6x12	5
2	487.2471.001.00.00	Inverter fixing plate	1
3	5787.06020.00.01	BOLT ,FLANGE M6x20	2
4	487.4695.001.00.00	Battery tape	1
5	487.2460.001.00.00	Battery 7Ah	1
6	487.6854.001.00.00	Voltage regulating rectifier 10A	1
7	6177.06000.00.01	Disc nut M6	4
8	487.3330.001.00.10	Battery box	1
9	487.6497.001.15.00	Inverter damper	1
10	5789.05012.00.01	BOLT ,FLANGE M5x12	2
11		Inverter cover	2
12	487.2470.001.00.00	inverter	1
13			

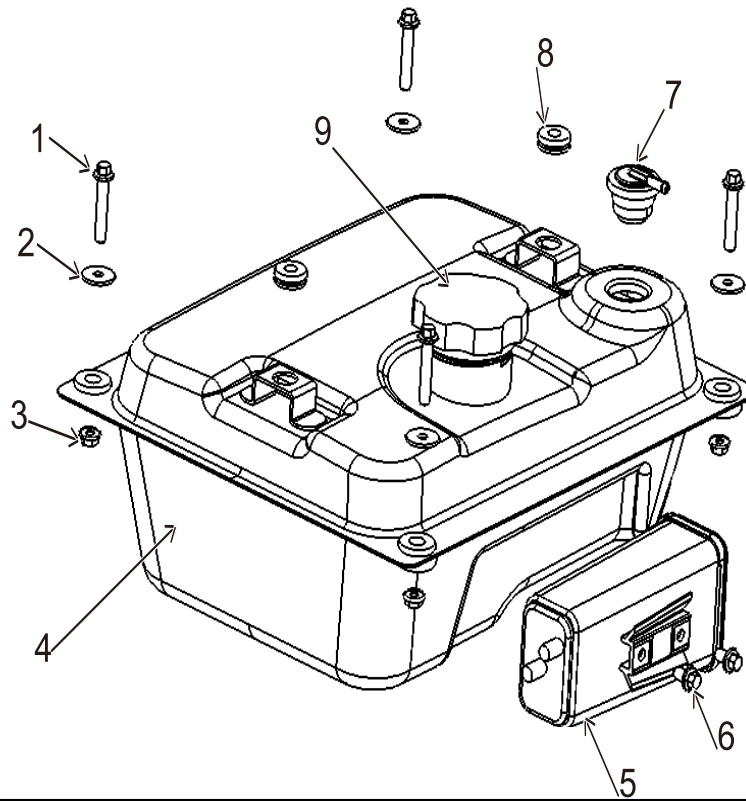

(FUEL TANK)

Ser.No	Part No.	Description	Quantity
1	5787.06040.00.01	BOLT ,FLANGE M6x40	4
2	460.4100.001.20.00	Flat pad 6*25*1.5	4
3	6177.06000.00.01	Disc nut M6	4
4	487.3200.003.00.00	tank	1
5	487.4440.001.00.00	Carbon canister 380cc	1
6	5787.06012.00.01	BOLT ,FLANGE M6x12	2
7	188.3200.C01.00.01	Check valve	1
8	467.5522.001.00.00	Tank support pad	2
9	487.3200.003.00.01	Tank cap	1
10			
11			
12			
13			

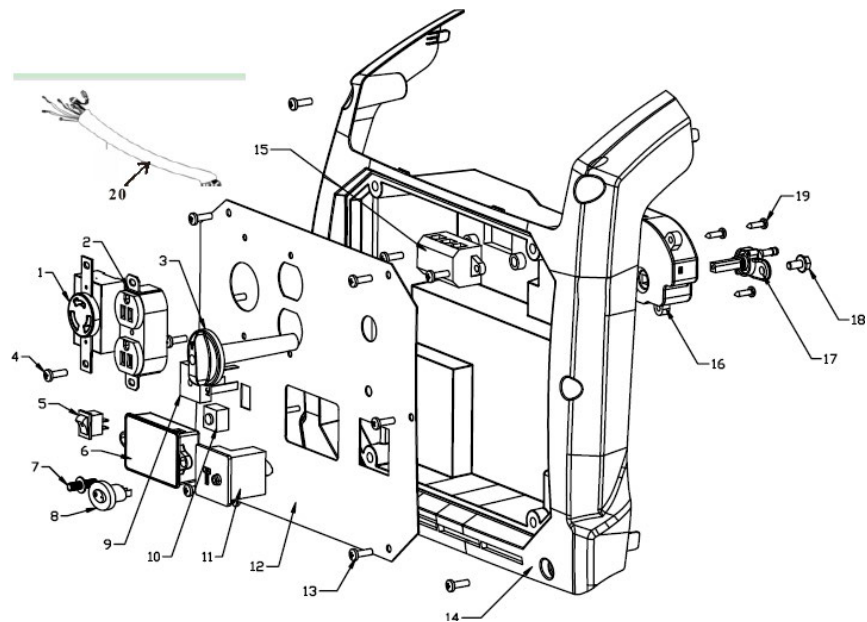

(CONTROL PANEL)

Ser.No	Part No.	Description	Quantity
1	520.3385.007.00.00	Socket	1
2	520.3385.007.00.00	Socket	1
3	487.7744.001.D7.00	Three in one switch handle	1
4	0818.05016.00.07	Cross recessed countersunk head screws M4*12	4
5	487.3370.007.00.01	Electric start switch	1
6	487.7590.001.00.00	Multifunctional digital display meter	1
7	487.3370.007.00.02	Ground terminal	1
8	487.3370.007.00.03	Energy-saving switch	1
9	487.6854.001.00.00	rectifier	1
10	487.3370.007.00.04	Cut-off switch	1
11	487.3370.007.00.07	DC socket (with over-current protection)	1
12	487.3370.007.00.00	panel	1
13	0818.05016.00.07	Cross recessed countersunk head screws M5*16	12
14	487.3370.001.04.01	Rear panel cover	1
15	487.3370.001.00.04	Terminal	1
16	487.2140.002.00.00	Three in one switch	1
17	487.3210.001.00.00	Oil switch	1
18	5787.06012.00.01	BOLT ,FLANGE M6x12	1
19	0845.42016.00.01	Self tapping screw ST4.2*16	3
20	487.3370.001.03.02	Wire harness	1

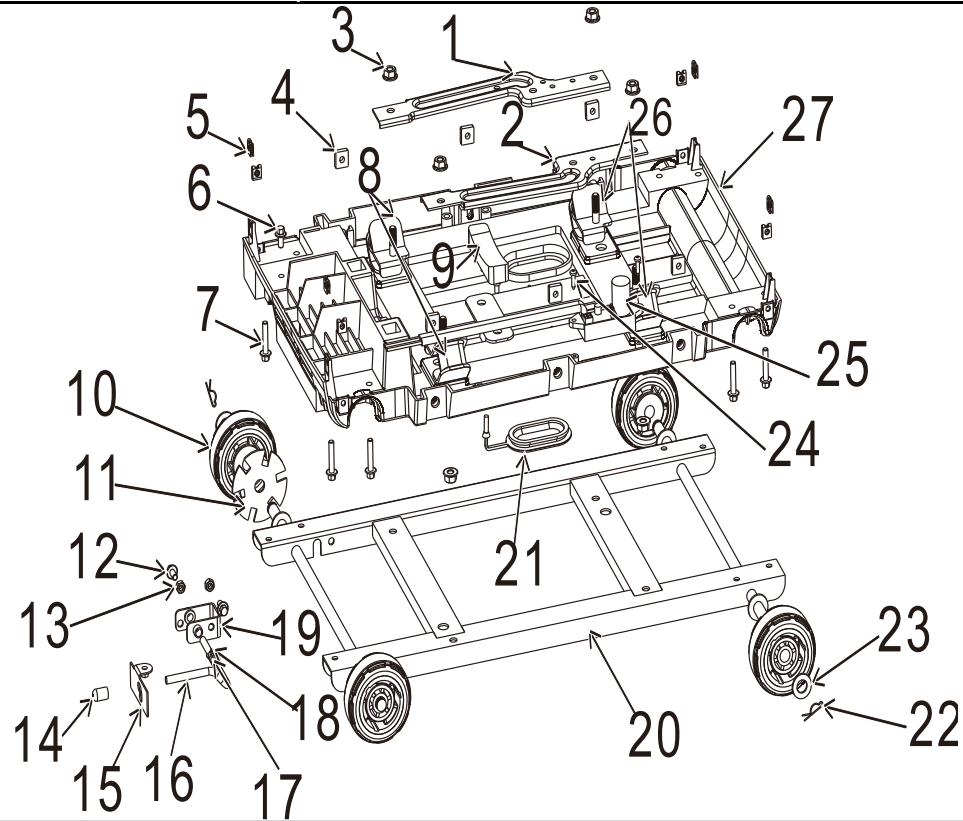

(FRAME)

Ser.No	Part No.	Description	Quantity
1	487.3340.001.00.00	Power plate 1	1
2	487.3340.002.00.00	Power plate 2	1
3	6177.08000.00.01	Disc nut M8	8
4	467.5926.001.00.00	Square nut M6	6
5	6178.05000.00.04	Clip nut M5	8
6	5787.06012.00.01	BOLT,FLANGE M6×12	1
7	5787.06030.00.01	BOLT,FLANGE M6×30	8
8	487.3360.001.00.00	Shock pad 1	2
9	487.3355.001.00.00	Dynamic support pad	1
10	487.3332.001.00.00	Wheels 3 inches	4
11	487.7721.002.00.00	Brake plate	1
12	5787.06012.00.01	Six angle flange bolt M6*12	2
13	0052.06000.00.02	Six angle nut M6	2

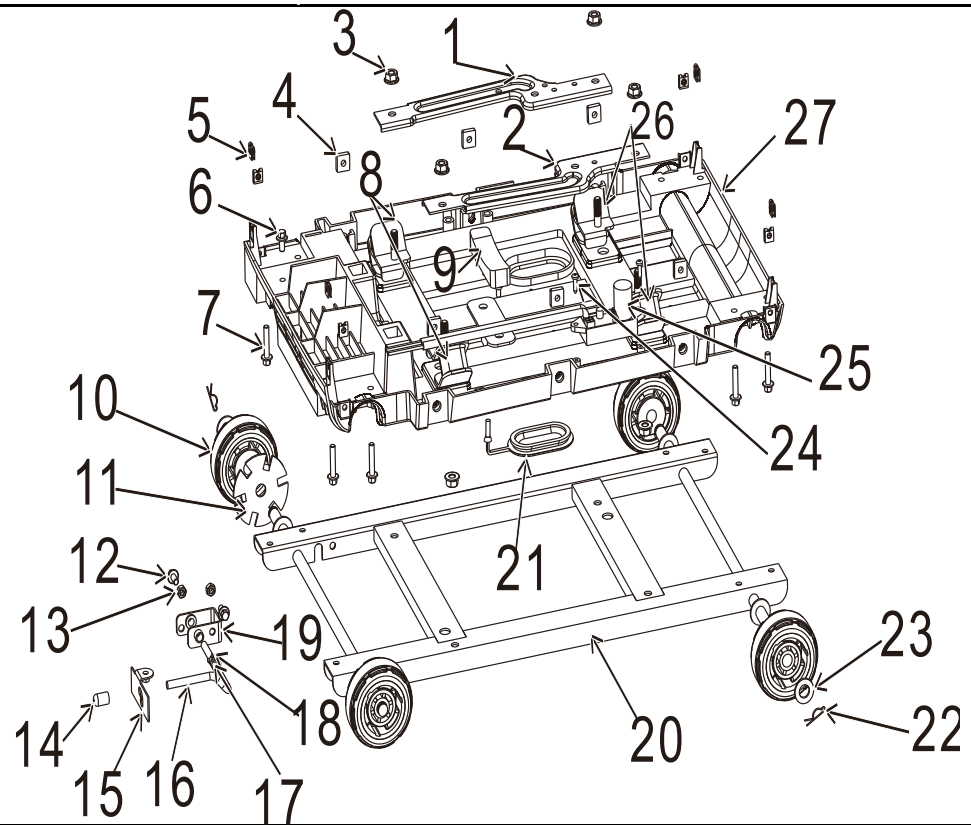

(FRAME)

Ser.No	Part No.	Description	Quantity
14	487.7722.001.00.01	Brake pull sleeve	1
15	487.7721.001.00.00	Brake gear plate	1
16	487.2272.001.00.00	Brake rail	1
17	487.1150.001.00.00	Brake spring	1
18	487.1176.001.00.00	Open circlip	1
19	487.7722.001.00.00	Brake mounting plate	1
20	487.3532.001.00.00	Floor assembly	1
21	487.3356.001.00.00	Chassis oil drain pad	1
22	168.1120.001.00.00	Swing lever lock	4
23	460.4100.002.20.00	Flat washer 13*24*2	4
24	0845.42016.00.01	Self tapping screw ST4.2*16	2
25	487.2110.002.00.00	Igniter	1
26	487.3360.003.00.00	Shock pad 3	2
27	487.4085.001.00.00	chassis	1

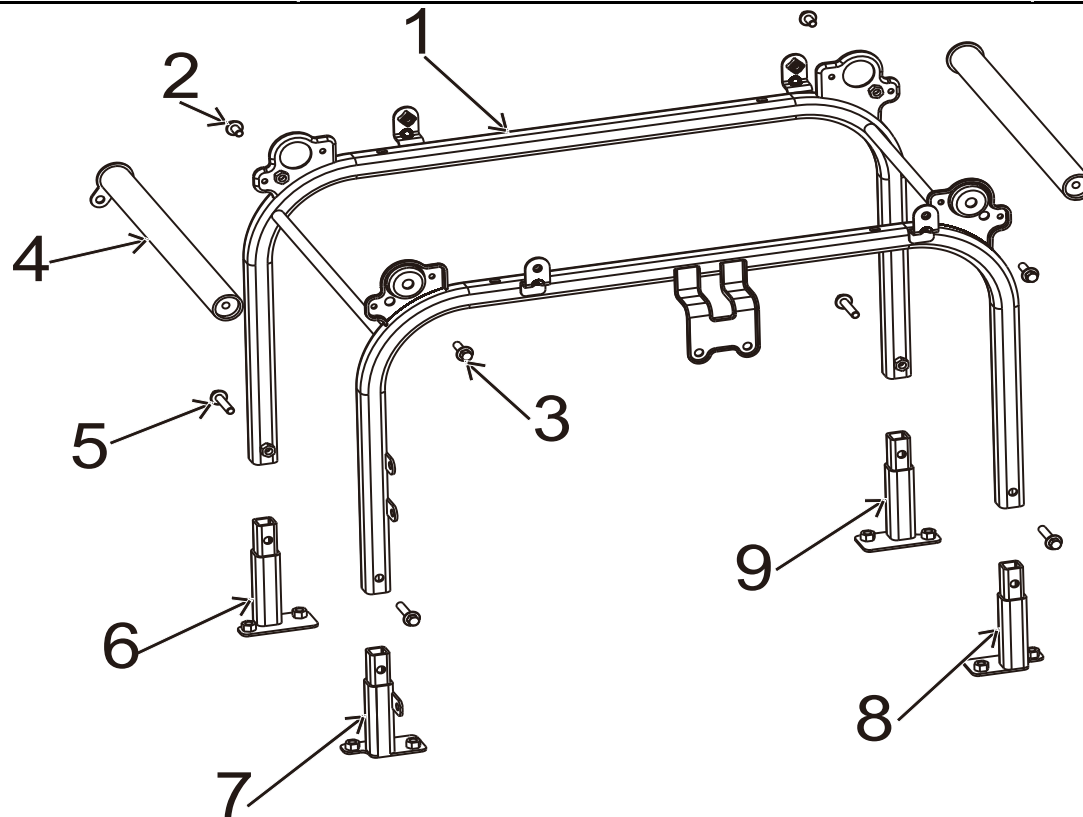

(FRAME)

Ser.No	Part No.	Description	Quantity
1	487.3330.002.B6.00	Frame	1
2	5787.06012.00.01	BOLT,FLANGE M6×12	2
3	5787.06020.00.01	BOLT,FLANGE M6×20	2
4	487.4821.001.J6.00	Handle tube	2
5	5787.06028.00.01	BOLT,FLANGE M6×28	4
6	487.3330.002.B6.01	Support foot 1	1
7	487.3330.002.B6.02	Support foot 2	1
8	487.3330.002.B6.03	Support foot 3	1
9	487.3330.002.B6.04	Support foot 4	1

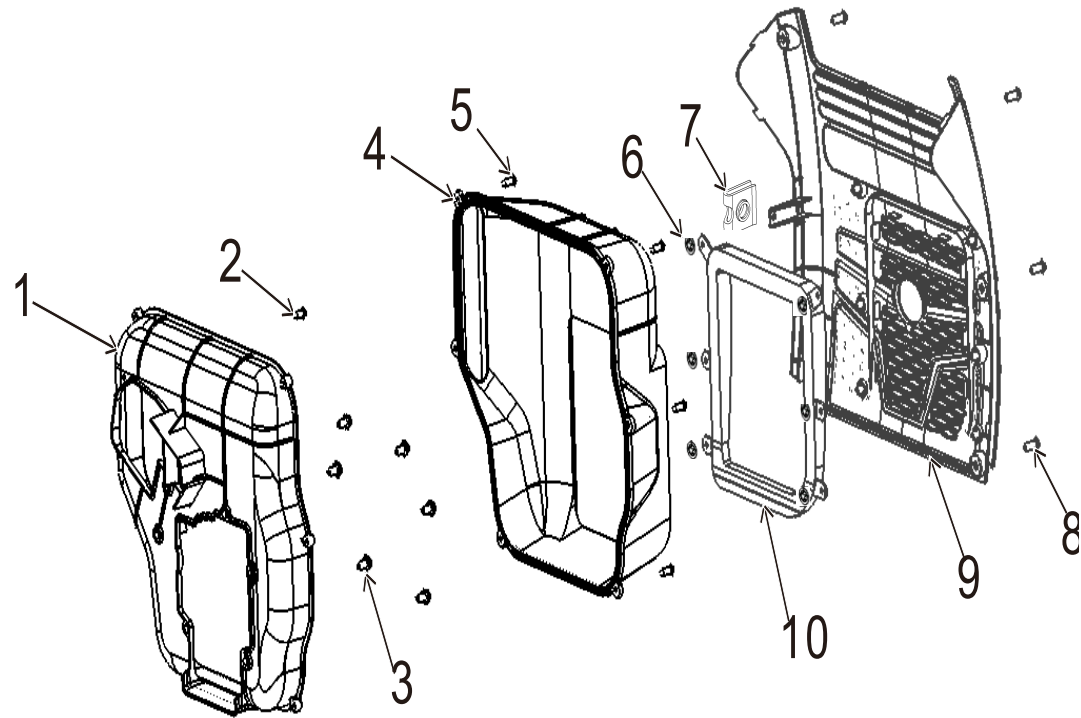

(PROTECTOR,MUFFLER)

Ser.No	Part No.	Description	Quantity
1	T70.2435.001.00.00	Muffler rear cover	1
2	0845.42013.00.01	Self tapping screw ST4.2*13	1
3	5789.05012.00.01	BOLT,FLANGE M5x12	6
4	T70.2402.001.00.00	Muffler front cover	1
5	0845.42013.00.01	Self tapping screw ST4.2*13	6
6	487.4100.001.00.00	Bearing thrust washerΦ5XΦ14X0.4	6
7	6178.05000.00.04	Clip nut M5	1
8	0818.05016.00.07	Cross recessed countersunk head screws (M5*16 H	5
9	487.4060.001.04.00	Tail cover	1
10	487.2450.001.00.00	Muffler insulation pad	1

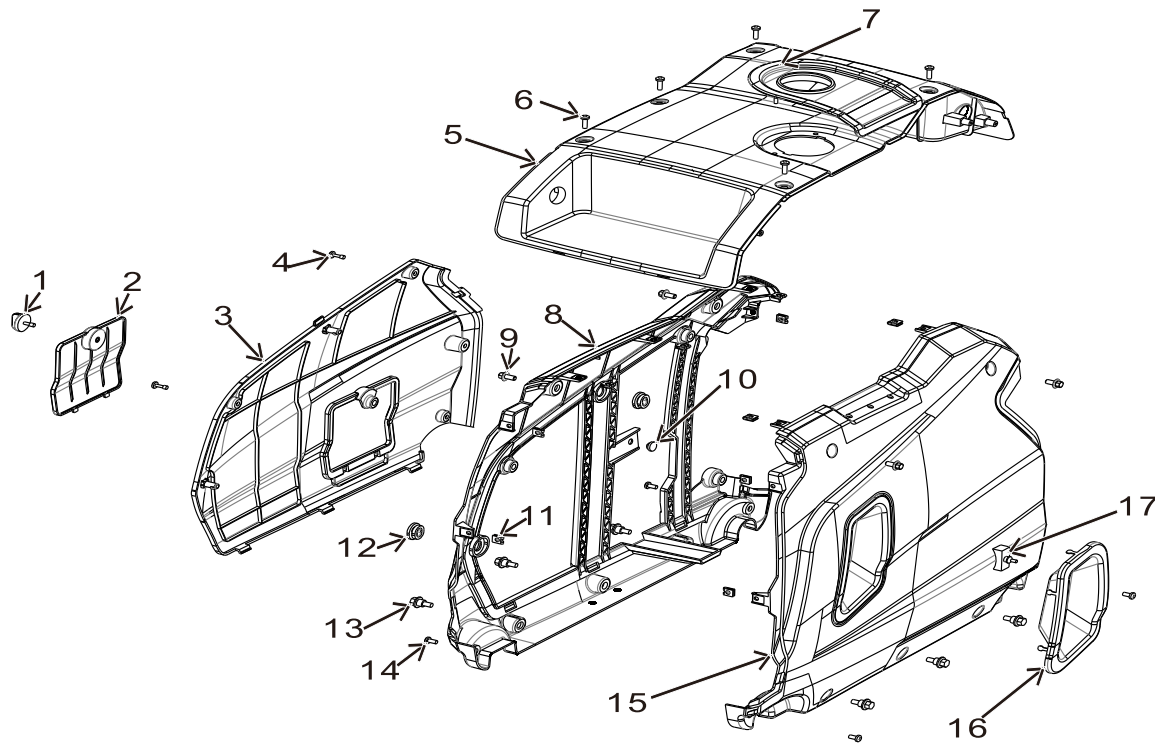

(APPEARANCE COVER)

Ser.No	Part No.	Description	Quantity
1	487.5572.001.00.01	Oil window handle	1
2	487.5572.001.00.00	Oil window	1
3	487.5576.003.00.00	Maintenance cover	1
4	0949.05014.00.07	M5*14.5 screw	4
5	487.5576.001.15.00	On the cover	1
6	0818.05016.00.07	Cross recessed countersunk head screws M5*16	5
7	487.4482.001.00.00	Oil guide rubber pad	1
8	487.5576.002.15.00	left cover	1
9	5787.06012.00.01	Plate boltM6*12	4
10	487.6612.001.00.00	Crash pad (cylinder head)	1
11	6178.05000.00.04	Clip nut M5	12
12	467.5522.002.00.00	Tank support pad B	2
13	467.4789.001.00.00	Step bolt M6	6
14	0818.05010.00.07	Cross recessed countersunk head screws M5*10/S=10.5	4
15	487.5576.004.15.00	Right cover	4
16	487.4629.001.00.00	Handle limit plate	1
17	487.6612.002.00.00	Crash pad (starting motor)	1