

TOMAHAWK

TG2000i
GASOLINE INVERTER GENERATOR

Operations Manual

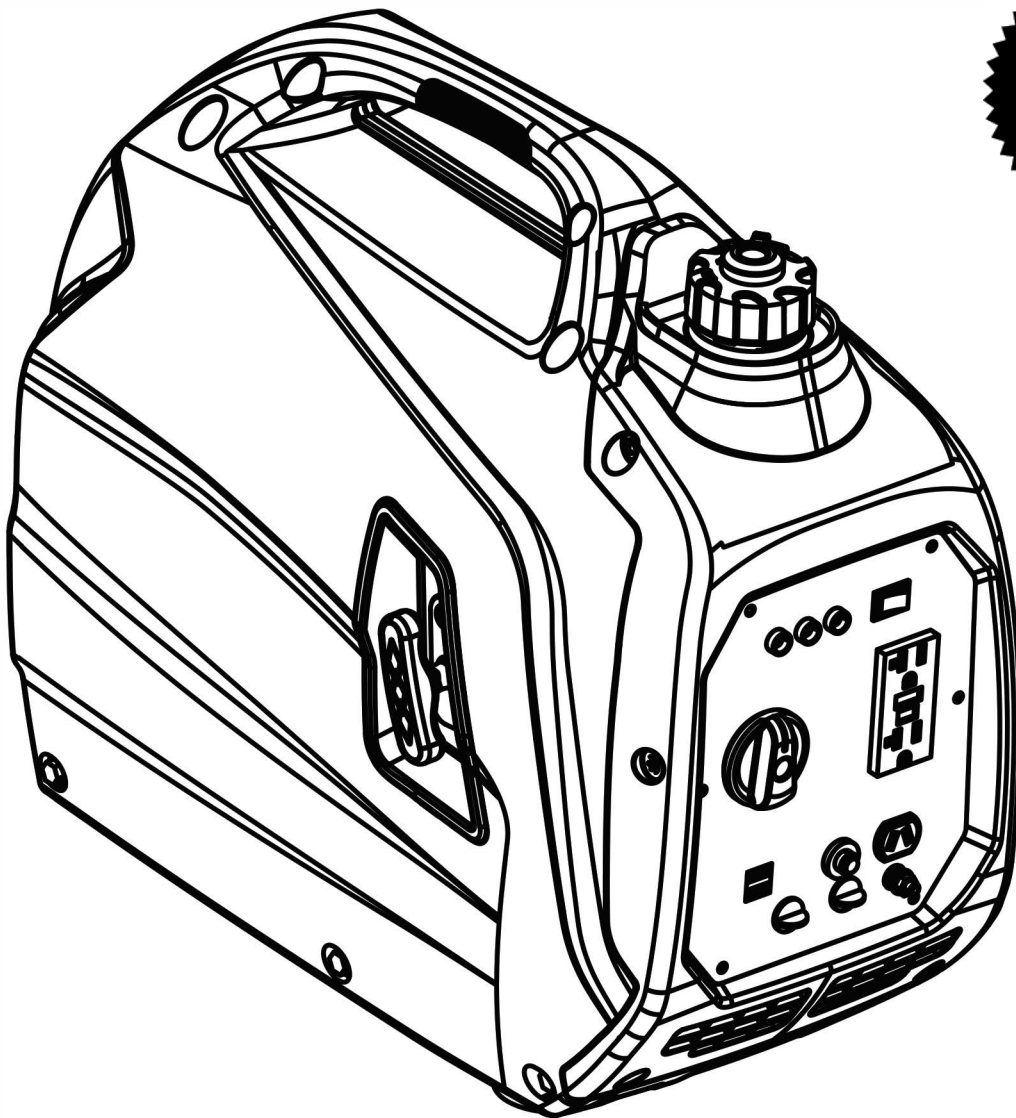

RUN WITH
SAE 10W-30 OIL
91 OCTANE GASOLINE



For safe operation follow all safety precautions in this Operations Manual. Improper use can cause serious injury.

Attention:

All information, illustrations and specifications in this manual are based on the latest information available at the time of publishing. The illustrations used in this manual are intended as representative reference views only. Moreover, because of our continuous product improvement policy, we may modify information, illustrations and/or specifications to explain and/or exemplify a product, service or maintenance improvement. Tomahawk Power LLC reserves the right to make any change at any time without notice. Some images may vary depending upon which model is shown.

Please Note:

California Proposition 65 Warning: The engine exhaust from this product contains chemicals known to the state of California to cause cancer, birth defects or other reproductive harm.

For Your Records:



This manual contains important instructions for operating this generator. For your safety and the safety of others, be sure to read this manual thoroughly before operating the generator. Failure to properly follow all instructions and precautions can cause you and others to be seriously hurt or killed.

Date of Purchase: _____ Generator Model Number: _____

Purchased from Store/Dealer: _____ Generator Serial Number: _____

Purchase Receipt: (retain your purchase receipt to ensure trouble-free warranty coverage)

Product Registration

To ensure trouble-free warranty coverage, it is important you register your Tomahawk generator. You can register your generator by either:

1. Filling in the product registration form below and mailing to:

Tomahawk Power LLC

1405 30th Street

San Diego, CA 92154

To register your generator you will need to locate the following information:

Model Number

Serial Number

Product Registration Form

PERSONAL INFORMATION

GENERATOR INFORMATION

First Name: _____ Model Number: _____

Last Name: _____ Serial Number: _____

Street Address: _____ Date Purchased: _____

Street Address: _____ Purchased From: _____

City, State, ZIP: _____

Country: _____

Phone Number: _____

E-Mail: _____

SAFETY DEFINITIONS

The words DANGER, WARNING, CAUTION and NOTICE are used throughout this manual to highlight important information. Be certain that the meanings of these alerts are known to all who work on or near the equipment.



This safety alert symbol appears with most safety statements. It means attention, become alert, your safety is involved! Please read and abide by the message that follows the safety alert symbol.

! DANGER

Indicates a hazardous situation which, if not avoided, *will* result in death or serious injury.

! WARNING

Indicates a hazardous situation which, if not avoided, *could* result in death or serious injury.

! CAUTION

Indicates a hazardous situation which, if not avoided, *could* result in minor or moderate injury.

NOTICE

Indicates a situation which can cause damage to the generator, personal property and/or the environment, or cause the equipment to operate improperly.

SAFETY SYMBOL DEFINITIONS

Symbol	Description
	Safety Alert Symbol
	Asphyxiation Hazard
	Burn Hazard
	Burst/Pressure Hazard
	Don't leave tools in the area
	Electrical Shock Hazard
	Explosion Hazard
	Fire Hazard
	Lifting Hazard
	Pinch-Point Hazard
	Read Manufacturer's Instructions
	Read Safety Messages Before Proceeding
	Wear Personal Protective Equipment (PPE)

SAFETY

GENERAL SAFETY RULES

! DANGER



Never use the generator in a location that is wet or damp. Never expose the generator to rain, snow, water spray or standing water while in use. Protect the generator from all hazardous weather conditions. Moisture or ice can cause a short circuit or other malfunction in the electrical circuit.

Never operate the generator in an enclosed area. Engine exhaust contains carbon monoxide. Only operate the generator outside and away from windows, doors and vents.

! WARNING



Voltage produced by the generator could result in death or serious injury.

- Never operate the generator in rain or a floodplain unless proper precautions are taken to avoid being subject to rain or a flood.
- Never use worn or damaged extension cords.
- Always have a licensed electrician connect the generator to the utility circuit.
- Never touch an operating generator if the generator is wet or if you have wet hands.
- Never operate the generator in highly conductive areas such as around metal decking or steel works.
- Always use grounded extension cords. Always use three-wire or double-insulated power tools.
- Never touch live terminals or bare wires while the generator is operating.
- Be sure the generator is properly grounded before operating.

⚠ WARNING



Gasoline and gasoline vapors are extremely flammable and explosive under certain conditions. Beware of Carbon Monoxide and odorless gas that kills.



- Always refuel the generator outdoors, in a well-ventilated area.
- Never remove the fuel cap with the engine running.
- Never refuel the generator while the engine is running. Always turn engine off and allow the generator to cool before refueling.
- Only fill fuel tank with gasoline.
- Keep sparks, open flames or other form of ignition (such as match, cigarette, static electric source) away when refueling.
- Never overfill the fuel tank. Leave room for fuel to expand. Overfilling the fuel tank can result in a sudden overflow of gasoline and result in spilled gasoline coming in contact with HOT surfaces. Spilled fuel can ignite. If fuel is spilled on the generator, wipe up any spills immediately. Dispose of rag properly. Allow area of spilled fuel to dry before operating the generator.
- Wear eye protection while refueling.
- Never use gasoline as a cleaning agent.
- Store any containers containing gasoline in a well-ventilated area, away from any combustibles or source of ignition.
- Check for fuel leaks after refueling. Never operate the engine if a fuel leak is discovered.

COMPONENT IDENTIFICATION

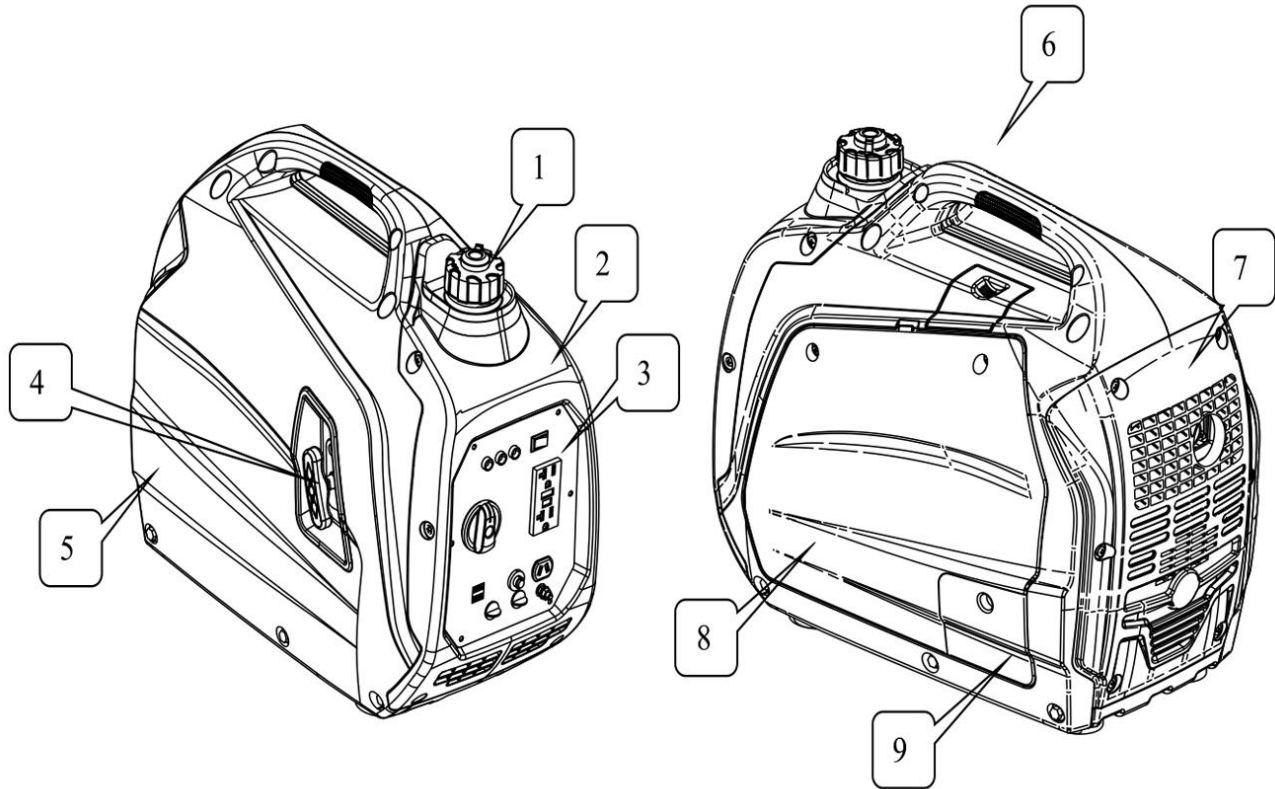

- 1. Fuel Tank Gap
- 2. Control Panel Base
- 3. Control Panel
- 4. Recoil Starter Grip
- 5. Left Shell

- 6. Handle
- 7. Muffler Cover Plate
- 8. Appearance Cover Plate
- 9. Engine Oil Cover Plate

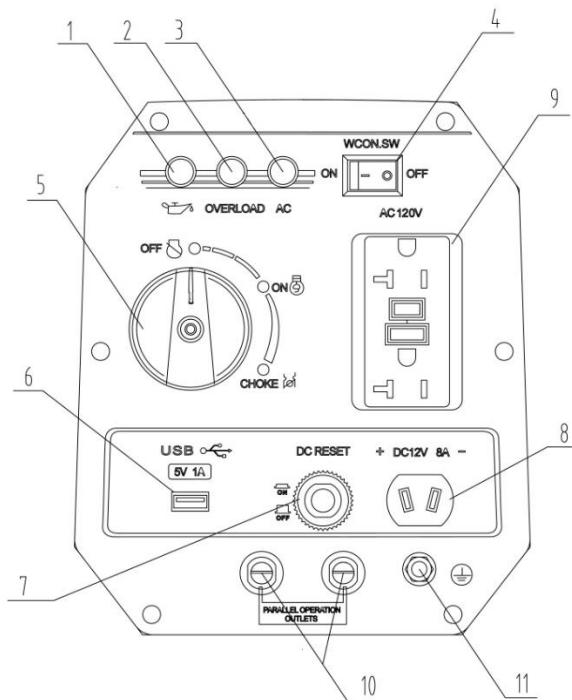

CONTROL PANEL

- 1. Low Oil Alert
- 2. Overload Alert
- 3. AC Indicator
- 4. Idle Switch
- 5. Switch
- 6. USB Outlet
- 7. DC Protector
- 8. DC Outlet
- 9. AC Outlet
- 10. Parallel Rectacle
- 11. Ground Terminal

BEFORE STARTING THE GENERATOR



Before starting the generator, review *Safety on page 7*.

Location Selection – Before starting the generator, avoid exhaust and location hazards by verifying:

- You have selected a location to operate the generator that is outdoors and well ventilated.
- You have selected a location with a level and solid surface on which to place the generator.
- You have selected a location that is at least 6 feet (1.8 m) away from any building, other equipment or combustible material.
- If the generator is located close to a building, make sure it is not located near any windows, doors and/or vents.

⚠ DANGER	⚠ PELIGRO
<p>USING A GENERATOR INDOORS CAN KILL YOU IN MINUTES. GENERATOR EXHAUST CONTAINS CARBON MONOXIDE. THIS IS A POISON YOU CANNOT SEE OR SMELL.</p>	<p>USAR EL GENERADOR EN INTERIORES LO PUEDE MATAR EN MINUTOS. EL ESCAPE DEL GENERADOR CONTIENE MONÓXIDO DE CARBONO. ESTE GAS ES UN VENENO QUE NO SE PUEDE VER NI OLER.</p>
<p>NEVER USE INSIDE A HOME OR GARAGE, EVEN IF DOORS AND WINDOWS ARE OPEN.</p>	<p>NUNCA USE EL GENERADOR DENTRO DEL HOGAR O EL GARAJE, AUN SI LAS PUERTAS Y VENTANAS ESTÁN ABIERTAS. SOLO ÚSELO EN EXTERIORES Y LEJOS DE VENTILACIONES, PUERTAS Y VENTANAS ABIERTAS.</p>
<p>ONLY USE OUTSIDE AND FAR AWAY FROM WINDOWS, DOORS, AND VENTS.</p>	

! WARNING



Always operate the generator on a level surface. Placing the generator on non-level surfaces can cause the generator to tip over, causing fuel and oil to spill. Spilled fuel can ignite if it comes in contact with an ignition source such as a very hot surface.

NOTICE

Only operate the generator on a solid, level surface. Operating the generator on a surface with loose material such as sand or grass clippings can cause debris to be ingested by the generator that could:

- Block cooling vents
- Block air intake system

Weather – Never operate your generator outdoors during rain, snow or any combination of weather conditions that could lead to moisture collecting on, in or around the generator.

Dry Surface – Always operate the generator on a dry surface free of any moisture.

No Connected Loads – Make sure the generator has no connected loads before starting it. To ensure there are no connected loads, unplug any electrical extension cords that are plugged into the control panel receptacles.

NOTICE

Starting the generator with loads already applied to it could result in damage to any appliance being powered off the generator during the brief start-up period.

Grounding the Generator – The National Electric Code (NEC), as well as many local electrical codes, require the generator to be connected to earth ground before operating. Before starting the generator, make sure it is connected to earth ground by connecting the ground terminal on the control panel (see Figure 12) to earth ground using copper wire (minimum 10 AWG). Consult a qualified electrician for local grounding requirements.



Figure 12 – Ground Terminal on the Control Panel

OPERATION

! WARNING



Be sure the generator is properly connected to earth ground before operating. The generator must be grounded to prevent electrical shock due to faulty appliances.

POWER CORD

Using Extension Cords

Tomahawk assumes no responsibility for the content within this table. The use of this table is the responsibility of the user only. This table is intended for reference only. The results produced by using this table are not guaranteed to be correct or applicable in all situations as the type and construction of cords are highly variable. Always check with local regulations and a licensed electrician prior to installing or connecting an electrical appliance.

Extension Cord Wire Gauge Size

AMPS	LENGTH OF EXTENSION CORD (ft)								
	10	20	30	40	50	60	80	100	120
5	20	18	16	14	12	12	10	10	8
10	18	16	14	12	12	10	10	8	8
15	16	14	12	12	10	10	8	8	6
20	14	12	12	10	10	8	8	6	6
25	12	12	10	10	8	8	6	6	6
30	12	10	10	8	8	6	6	6	6
35	10	10	8	8	6	6	6	6	6

ADDING / CHECKING ENGINE FLUIDS AND FUEL



Before adding/checking engine fluids and fuel, review *Safety on page 7*.

! DANGER



Filling the fuel tank with gasoline while the generator is running can cause gasoline to leak and come in contact with hot surfaces that can ignite the gasoline.

Before starting the generator, always check the level of:

- Engine oil
- Gasoline in the fuel tank

Once the generator is started and the engine gets warm, it is not safe to add gasoline to the fuel tank or engine oil to the engine while the engine is running or the engine and muffler are hot.

Checking and / or Adding Engine Oil

! WARNING



Internal pressure can build in the engine crankcase while the engine is running. Removing the oil fill plug/dipstick while the engine is hot can cause extremely hot oil to spray out of the crankcase and can severely burn skin. Allow engine oil to cool for several minutes before removing the oil fill plug/dipstick.

The unit as shipped does not contain oil in the engine. You must add engine oil before starting the generator for the first time. See *Checking Engine Oil on page 28* and *Adding Engine Oil on page 29* for instructions on checking engine oil level and the procedure for adding engine oil.

NOTICE

The generator does not contain engine oil as shipped. Attempting to start the engine without adding engine oil can permanently damage internal engine components.

Adding Gasoline to the Fuel Tank

! WARNING



Never refuel the generator while the engine is running.



Always turn the engine off and allow the generator to cool before refueling.

Required Gasoline – Only use gasoline that meets the following requirements:

- Unleaded gasoline only
- Gasoline with maximum 10% ethanol added
- Gasoline with an 91 octane rating or higher

Filling the Fuel Tank – Follow the steps below to fill the fuel tank:

1. Shut off the generator.
2. Allow the generator to cool down so all surface areas of the muffler and engine are cool to the touch.
3. Move the generator to a flat surface.
4. Clean area around the fuel cap.
5. Remove the fuel cap by rotating counterclockwise.
6. Slowly add gasoline into the fuel tank. Be very careful not to overfill the tank. The gasoline level should NOT be higher than the filler neck (see *Figure 15*).
7. Install the fuel cap by rotating clockwise until you hear a click, indicating the cap is completely installed.

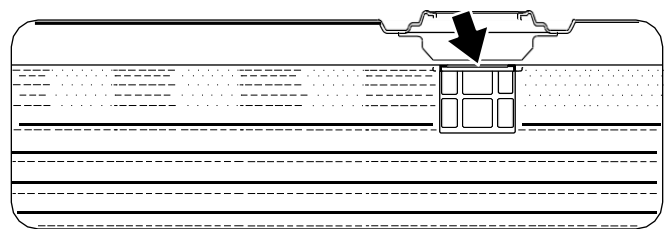

Figure 15 – Maximum Gasoline Fill Level

! CAUTION



Avoid prolonged skin contact with gasoline. Avoid prolonged breathing of gasoline vapors.

OPERATION

STARTING THE GENERATOR



Before starting the generator, review Safety on page 7.

Before attempting to start the generator, verify the following:

- The engine is filled with engine oil (see *Checking Engine Oil on page 28*).
- The generator is situated in a proper location (see *Location Selection on page 19*).
- The generator is on a dry surface (see *Weather and Dry Surface on page 19*).
- All loads are disconnected from the generator (see *No Connected Loads on page 19*).
- The generator is properly grounded (see *Grounding the Generator on page 19*).

! DANGER



Never use the generator in a location that is wet or damp. Never expose the generator to rain, snow, water spray or standing water while in use. Protect the generator from all hazardous weather conditions. Moisture or ice can cause a short circuit or other malfunction in the electrical circuit.

Never operate the generator in an enclosed area. Engine exhaust contains carbon monoxide. Only operate the generator outside and away from windows, doors and vents.

NOTICE

The engine is equipped with a low oil shutdown switch. If the oil level becomes low, the engine will shut down and will not start until the oil is filled to the proper level.

Be sure the engine has the proper oil level before using. Failure to verify that the engine has the proper oil level could result in engine damage.

Disconnect all loads from the generator before starting. Failure to verify all loads are disconnected prior to starting the generator could result in damage to the connected appliances.

Manually Starting a Generator

NOTE: This procedure can also be used on an electric start generator.

1. Make sure the circuit breakers are properly set (see *Figure 16*).

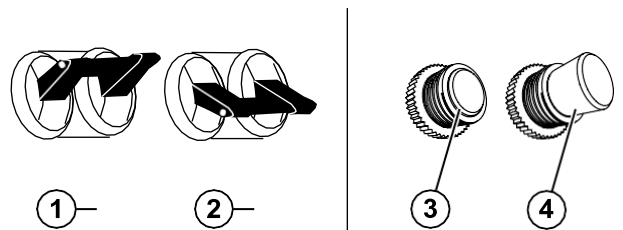

Figure 16 – Breakers

1 - 240/120V Main Circuit Breaker Operating Position

2 - 240/120V Main Circuit Breaker Tripped Position

3 - 120V Circuit Breaker Operating Position

4 - 120V Circuit Breaker Tripped Position

- 1) Fuel Tank Cap
 - a. Open the fuel tank cap Counterclockwise

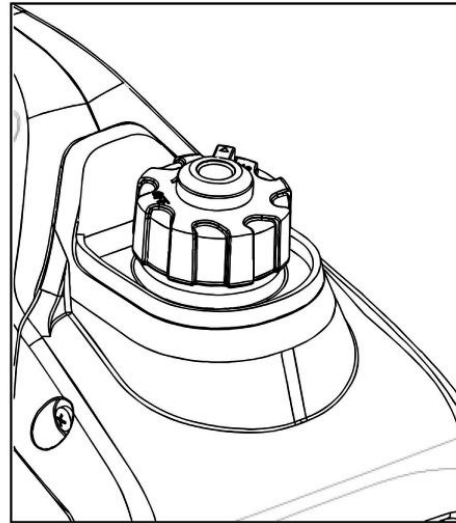

- 2) Grounding Terminal
 - a. To prevent electrical shock, ground the generator. The grounding terminal is located on the control panel.

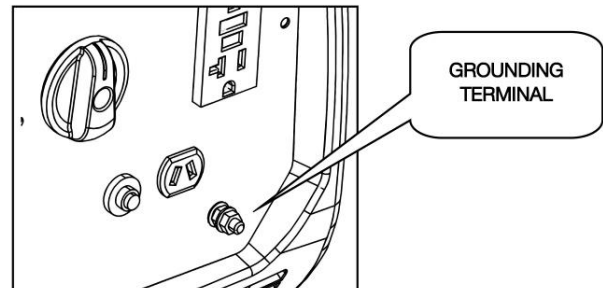

- 3) Start the Generator
 - a. Put the ECO switch to the "OFF" position
 - b. Twist the cap ventilation button to the "ON" position
 - c. Twist the switch to the "CHOKE" position
 - i. Open the fuel
 - ii. Open the Ignition System
 - iii. Close the Choke

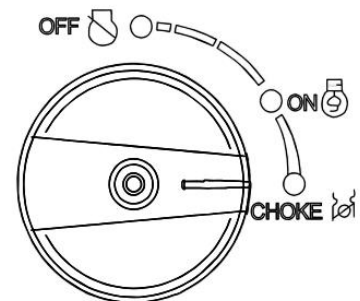
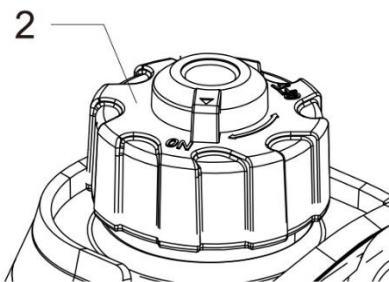

Note: If the generator is hot when starting the engine, do not close the choke. Turn the switch to the "ON" position.

- 4) Pull the recoil cord slightly. When you feel the recoil force, pull the handle forcefully.

Note: Hold the handle of the inverter generator when pulling the recoil cord. This is to prevent the generator from tipping over.

1) STOPPING THE GENERATOR

- a. Turn the ECO Switch to the "OFF" position
- b. Stop all electrical equipment
- c. Turn the knob to the "OFF" Position.
- d. Close the fuel and ignition system
- e. Turn the fuel cap ventilation buton to the "OFF" position when the generator is totally cold

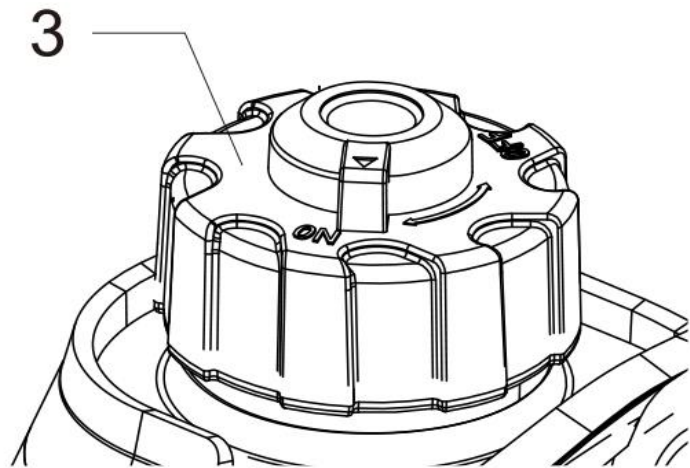
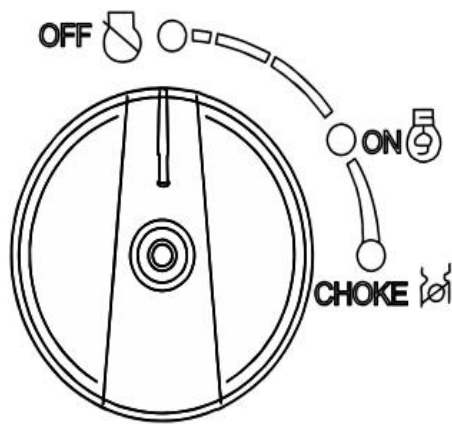

MAINTENANCE

MAINTENANCE



Before performing maintenance on the generator, review *Safety on page 7* and the following safety messages.

! WARNING	
	Avoid accidentally starting the generator during maintenance by removing the spark plug boot from the spark plug. For electric start generators, also disconnect the battery cables from the battery (disconnect the black negative (-) cable first) and place the cables away from the battery posts to avoid arcing.
	Allow hot components to cool to the touch prior to performing any maintenance procedure.
	Internal pressure can build in the engine crankcase while the engine is running. Removing the oil fill plug/dipstick while the engine is hot can cause extremely hot oil to spray out of the crankcase and can severely burn skin. Allow engine oil to cool for several minutes before removing the oil fill plug/dipstick.
	Always perform maintenance in a well-ventilated area. Gasoline fuel and fuel vapors are extremely flammable and can ignite under certain conditions.

! CAUTION	
	Avoid skin contact with engine oil or gasoline. Prolonged skin contact with engine oil or gasoline can be harmful. Frequent and prolonged contact with engine oil may cause skin cancer. Take protective measures and wear protective clothing and equipment. Wash all exposed skin with soap and water.

Maintenance Schedule

! WARNING	
	Failure to perform periodic maintenance or not following maintenance procedures can cause the generator to malfunction and could result in death or serious injury.

NOTICE	
	Periodic maintenance intervals vary depending on generator operating conditions. Operating the generator under severe conditions, such as sustained high-load, high-temperature, or unusually wet or dusty environments, will require more frequent periodic maintenance. The intervals listed in the maintenance schedule should be treated only as a general guideline.

Following the maintenance schedule is important to keep the generator in good operating condition. The following is a summary of maintenance items by periodic maintenance intervals.

Table 1: Maintenance Schedule - Owner Performed

Maintenance Item	Before Every Use	After First 20 Hours or First Month of Use	After 50 Hours of Use or Every 3 Months	After 100 Hours of Use or Every 6 Months	After 300 Hours of Use or Every Year
Engine Oil	Check Level	Change	Change	–	–
Cooling Features	Check/Clean	–	–	–	–
Air Filter	Check	–	Clean ¹	–	Replace
Spark Plug	–	–	–	Check/Clean	Replace
Spark Arrestor	–	–	–	Check/Clean	–

¹ Service more frequently if operating in dry and dusty conditions.

Table 2: Maintenance Schedule – Authorized Tomahawk Service Dealer Performed

Maintenance Item	Before Every Use	After First 20 Hours or First Month of Use	After 50 Hours of Use or Every 3 Months	After 100 Hours of Use or Every 6 Months	After 300 Hours of Use or Every Year
Valve Clearance	–	–	–	–	Check/Adjust
Fuel Filter	–	–	–	Check/Clean	–
Idle Speed	–	–	–	–	Check/Adjust

ENGINE OIL MAINTENANCE

Engine Oil Specification

1. Only use the engine oil specified in *Figure 25*.
2. Only use 4-stroke/cycle engine oil. NEVER USE 2-STROKE/CYCLE OIL. Synthetic oil is an acceptable substitute for conventional oil.

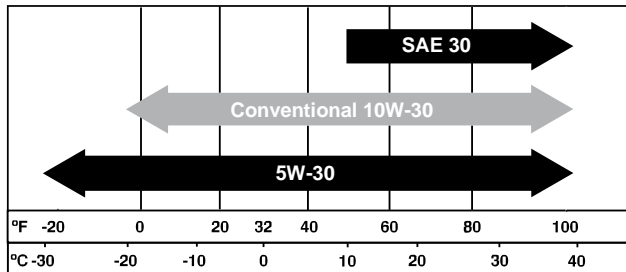

Figure 25 – Recommended Oil

Checking Engine Oil

NOTICE

Always maintain proper engine oil level. Failure to maintain proper engine oil level could result in severe damage to the engine and/or shorten the life of the engine.

Always use the specified engine oil. Failure to use the specified engine oil can cause accelerated wear and/or shorten the life of the engine.

Engine oil level should be checked before every use.

1. Always operate or maintain the generator on a flat surface.
2. Stop engine if running.
3. Let engine sit and cool for several minutes (allow crankcase pressure to equalize).
4. With a damp rag, clean around the oil fill plug/dipstick.
5. Remove oil fill plug/dipstick

Check oil level:

When checking the engine oil, remove the oil fill plug/dipstick and wipe it clean. Thread the oil fill plug/dipstick all the way back in and then remove and check the oil level on the oil fill plug/dipstick.

- Acceptable Oil Level – Oil is visible on the cross-hatches between the H and L lines on the oil fill plug/dipstick (*see Figure 27*).
- Low Oil – Oil is below the L line on the oil fill plug/dipstick.

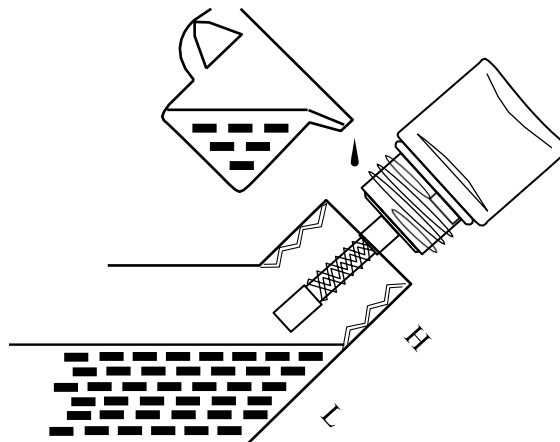

Figure 27 – Checking Oil Level

MAINTENANCE

Adding Engine Oil

1. Always operate or maintain the generator on a flat surface.
2. Stop engine if running.
3. Let engine sit and cool for several minutes (allow crankcase pressure to equalize).
4. Thoroughly clean around the oil fill plug/dipstick.
5. Remove oil fill plug/dipstick and wipe clean.
6. Select the proper engine oil
7. Using the supplied funnel and tube, slowly add engine oil to the engine. Stop frequently to check the level to avoid overfilling).
8. Continue to add oil until the oil is at the correct level.

Changing Engine Oil

1. Stop the engine.
2. Let engine sit and cool for several minutes (allow crankcase pressure to equalize).
3. Place oil pan (or suitable container) under the oil drain plug.
4. With a damp rag, thoroughly clean around the oil drain plug.

5. Remove the oil drain plug. Once removed, place the oil drain plug on a clean surface.
6. Remove the oil fill plug so the oil can drain more easily from the oil drain port.
7. Allow oil to completely drain.
8. Replace oil drain plug.
9. Fill crankcase with oil following the steps outlined in

NOTICE

Never dispose of used engine oil by dumping the oil into a sewer, on the ground, or into groundwater or waterways. Always be environmentally responsible. Follow the guidelines of the EPA or other governmental agencies for proper disposal of hazardous materials. Consult local authorities or reclamation facility.

10. Dispose of used engine oil properly.

AIR FILTER MAINTENANCE

! WARNING



Never use gasoline or other flammable solvents to clean the air filter. Use only household detergent soap to clean the air filter.

MAINTENANCE

Cleaning the Air Filter

The air filter must be cleaned after every 50 hours of use or 3 months (frequency should be increased if generator is operated in a dusty environment).

1. Turn off the generator and let it cool for several minutes if running.
2. Move the generator to a flat, level surface.
3. Unclip the clips on the top and bottom of the air filter cover and remove the air filter cover.

4. Remove the black coarse outside air filter
5. Remove the gray fine inside the air filter

6. Wash the foam air filter elements by submerging the elements in a solution of household detergent soap and warm water. Slowly squeeze the foam to thoroughly clean.

NOTICE

NEVER twist or tear the foam air filter element during cleaning or drying. Only apply slow but firm squeezing action.

7. Rinse in clean water by submerging the air filter elements in fresh water and applying a slow squeezing action.

NOTICE

Never dispose of soap cleaning solution used to clean the air filter by dumping the solution into a sewer, on the ground, or into groundwater or waterways. Always be environmentally responsible. Follow the guidelines of the EPA or other governmental agencies for proper disposal of hazardous materials. Consult local authorities or reclamation facility.

8. Dispose of used soap cleaning solution properly.

9. Dry the air filter elements by again applying a slow firm squeezing action.
10. Once the air filters are dry, coat the air filters with clean engine oil (see *Figure 33*).
14. Install the air filter cover by clipping the clips on the top and bottom of the air filter assembly

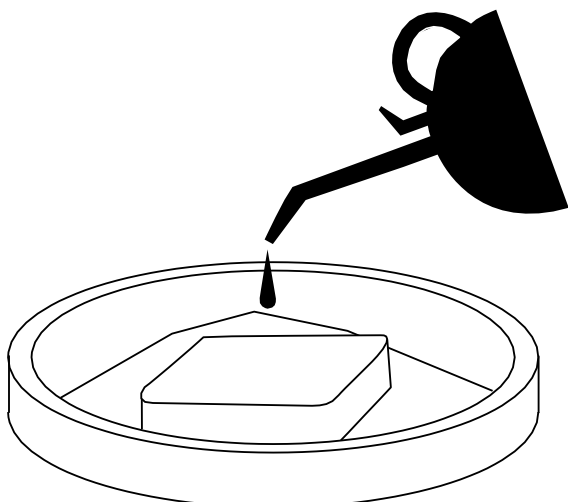

Figure 33

11. Squeeze the filters to remove any excess oil (see *Figure 34*).

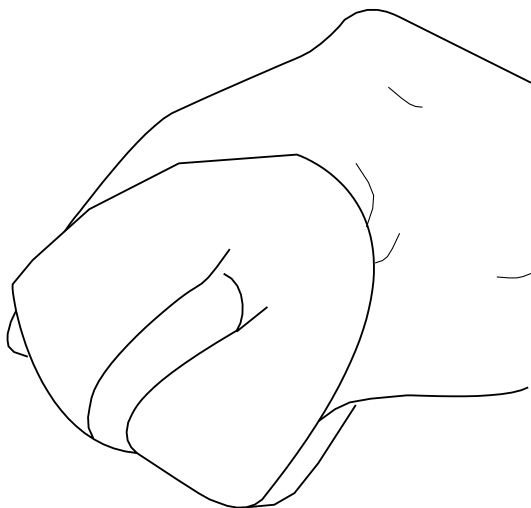

Figure 34

12. Install the gray fine inside air filter into the air filter housing first.
13. Install the black coarse outside air filter on top of the fine filter.

MAINTENANCE

SPARK PLUG MAINTENANCE

The spark plug must be checked and cleaned after every 100 hours of use or 6 months and must be replaced after 300 hours of use or every year.

1. Stop the generator and let it cool for several minutes if running.
2. Move the generator to a flat, level surface.
3. Remove the spark plug boot by firmly pulling the plastic spark plug boot handle directly away from the engine.

NOTICE

Never apply any side load or move the spark plug laterally when removing the spark plug. Applying a side load or moving the spark plug laterally may crack and damage the spark plug boot.

4. Clean area around the spark plug.
5. Using the 13/16" spark plug socket wrench provided, remove the spark plug from the cylinder head.

6. Place a clean rag over the opening created by the removal of the spark plug to make sure no dirt can get into the combustion chamber.
7. Inspect the spark plug for:
 - Cracked or chipped insulator
 - Excessive wear
 - Spark plug gap (the acceptable limit of 0.024 – 0.032 in. [0.60 – 0.80 mm]) (see *Figure 38*).

If the spark plug fails any one of the conditions listed above, replace the plug with a Champion RN9YC plug or equivalent.

8. Install the spark plug by carefully following the steps outlined below:
 - a - Carefully insert the spark plug back into the cylinder head. Hand-thread the spark plug until it bottoms out.
 - b - Using the 13/16" spark plug socket wrench provided, turn the spark plug to ensure it is fully seated.
 - c - Replace the spark plug boot, making sure the boot fully engages the spark plug's tip.

Recommended Spark Plug Replacement:

AutoLite	63
Champion	RN9YC
Bosch	WR7DS
Torch	F6RTC

NOTICE

Only use the recommended spark plug (Champion RN9YC or equivalent). Using a non-recommended spark plug could result in damage to the engine.

MAINTENANCE

NOTICE

Dispose of the used battery properly according to the guidelines established by your local or state government.

2. Install the new battery into the generator frame.
3. Connect the red positive (+) battery cable to the battery first.
4. Connect the black negative (-) battery cable to the battery second.
5. Install the battery hold-down plate using the nuts

removed in step 2.

6. Install the spark plug wire onto spark plug.

The battery is the same as a motorcycle/utility battery.

Type	14L-A2
Tomahawk Model No.	100284
Batteries Plus Model No.	WKPC12-14NB
Volts	12
Amp	14
Dimensions (L x H x W)	6.0 x 3.75 x 3.75 in. (15.2 x 9.4 x 9.4 cm)

CLEANING THE SPARK ARRESTOR

Check and clean the spark arrester after every 100 hours of use or 6 months.

1. Stop the generator and let it cool for several minutes if running.
2. Move the generator to a flat, level surface.
3. Using a flathead screwdriver, loosen the spark arrester band clamp (see Figure 42).

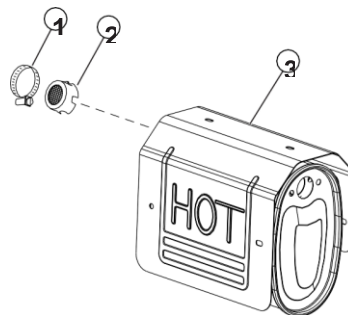

1 - Spark Arrester Band Clamp

3 - Muffler

2 - Spark Arrester Screen

4. Slide the spark arrester band clamp off the spark arrester screen.
5. Pull the spark arrester screen off the muffler exhaust pipe.
6. Using a wire brush, remove any dirt and debris that may have collected on the spark arrester screen.
7. If the spark arrester screen shows signs of wear (rips, tears or large openings in the screen), replace the spark arrester screen.
8. Install the spark arrester components in the following order:
 - a - Place spark arrester screen over the muffler exhaust pipe. Push on the screen until it fully bottoms out.
 - b - Place the spark arrester band clamp over the screen and tighten with a flathead screwdriver.

MAINTENANCE

STORAGE

! WARNING



Never store a generator with fuel in the tank indoors or in a poorly ventilated area where the fumes can come in contact with an ignition source such as a: 1) pilot light of a stove, water heater, clothes dryer or any other gas appliance; or 2) spark from an electric appliance.

NOTICE

Gasoline stored for as little as 60 days can go bad, causing gum, varnish and corrosive buildup in fuel lines, fuel passages and the engine. This corrosive buildup restricts the flow of fuel, preventing an engine from starting after a prolonged storage period.

Proper care should be taken to prepare the generator for any storage.

1. Clean the generator
2. Drain all gasoline from the fuel tank as best as possible.
3. With the fuel shutoff valve open, start the engine and allow the generator to run until all the remaining gasoline in the fuel lines and carburetor is consumed and the engine shuts off.
4. Close the fuel shutoff valve.
5. Change the oil (*see Changing Engine Oil on page 29*).
6. Remove the spark plug (*see Spark Plug Maintenance on page 32*) and place about 1 tablespoon of oil in the spark plug opening. While placing a clean rag over the spark plug opening, slowly pull the recoil handle to allow the engine to turn over several times. This will distribute the oil and protect the cylinder wall from corroding during storage.
7. Replace the spark plug (*see Spark Plug Maintenance on page 32*).
8. Move the generator to a clean, dry place for storage.

TROUBLESHOOTING

! WARNING



Before attempting to service or troubleshoot the generator, the owner or service technician must first read the owner's manual and understand and follow all safety instructions. Failure to follow all instructions may result in conditions that can lead to voiding of the EPA certification or product warranty, serious personal injury, property damage or even death.

PROBLEM	POTENTIAL CAUSE	SOLUTION
Engine is running, but no electrical output.	1. Circuit breakers are tripped.	1. Reset the circuit breakers and check for overload condition (<i>see pages 23 and 25</i>).
	2. The power cord's plug connector is not fully engaged in the generator's outlet.	2. Verify plug connector is firmly engaged in the generator's outlet. If using the 240V outlet, make sure plug connector is rotated 1/4 turn in the clockwise direction.
	3. Faulty or defective power cord	3. Replace power cord.
	4. Faulty or defective electrical appliance	4. Try connecting a known good appliance to verify the generator is producing electrical power.
	5. GFCI outlet is tripped	5. Press the reset button on the GFCI outlet (<i>see page 33</i>).
	6. If trying 1-5 above does not solve the problem, the cause might be the generator has a fault.	6. Take the generator to your nearest authorized service dealer.

TROUBLESHOOTING

PROBLEM	POTENTIAL CAUSE	SOLUTION
Engine will not start or remain running while trying to start.	1. Fuel shutoff valve is in the OFF position.	1. Move the fuel shutoff valve to the ON position (see pages 24 and 25).
	2. Generator is out of gasoline.	2. Add gasoline to the generator (see page 22).
	3. Fuel flow is obstructed.	3. Inspect and clean fuel delivery passages.
	4. Unit is overchoked.	4. Move the choke lever halfway between the ON and OFF positions (see pages 24 and 25).
	5. Starting battery may have insufficient charge	5. On electric start models only. Check battery output and charge battery as necessary.
	6. Dirty air filter	6. Check and clean the air filter (see pages 29-31).
	7. Low oil level shutdown switch is preventing the unit from starting.	7. Check oil level and add oil if necessary (see pages 28 and 29).
	8. Spark plug boot is not fully engaged with the spark plug tip.	8. Firmly push down on the spark plug boot to ensure the boot is fully engaged (see pages 32 and 33).
	9. Spark plug is faulty.	9. Remove and check the spark plug. Replace if faulty (see pages 32 and 33).
	10. Dirty/plugged spark arrestor	10. Check and clean the spark arrestor (see page 34).
	11. Stale fuel	11. Drain fuel and replace with fresh fuel (see page 22).
	12. If trying 1-11 above does not solve the problem, the cause might be the generator has a fault.	12. Take the generator to your nearest authorized service dealer.
Generator suddenly stops running.	1. Generator is out of fuel.	1. Check fuel level (see page 22). Add fuel if necessary.
	2. The low oil shutdown switch has stopped the engine.	2. Check oil level and add oil if necessary (see pages 28 and 22).
	3. Too much load	3. Restart the generator and reduce the load.
	4. If trying 1-3 above does not solve the problem, the cause might be a fault in the generator.	4. Take the generator to your nearest authorized service dealer.
Engine runs erratic; does not hold a steady RPM.	1. Choke was left in the ON position.	1. Move choke to the OFF position (see pages 24 and 25).
	2. Dirty air filter	2. Clean the air filter (see pages 29-31).
	3. Applied loads may be cycling on and off	3. As applied loads cycle, changes in engine speed may occur; this is a normal condition.
	4. If trying 1-3 above does not solve the problem, the cause might be a fault in the generator	4. Take the generator to your nearest authorized service dealer.

TOMAHAWK

Tomahawk Power, LLC
San Diego, CA

Sales Support

(866) 577-4476

sales@tomahawk-power.com

Service and Registration

support@tomahawk-power.com

www.tomahawk-power.com