

TOMAHAWK

PORTABLE TROWEL

MODEL NUMBER: JXPT30T

Operation Manual

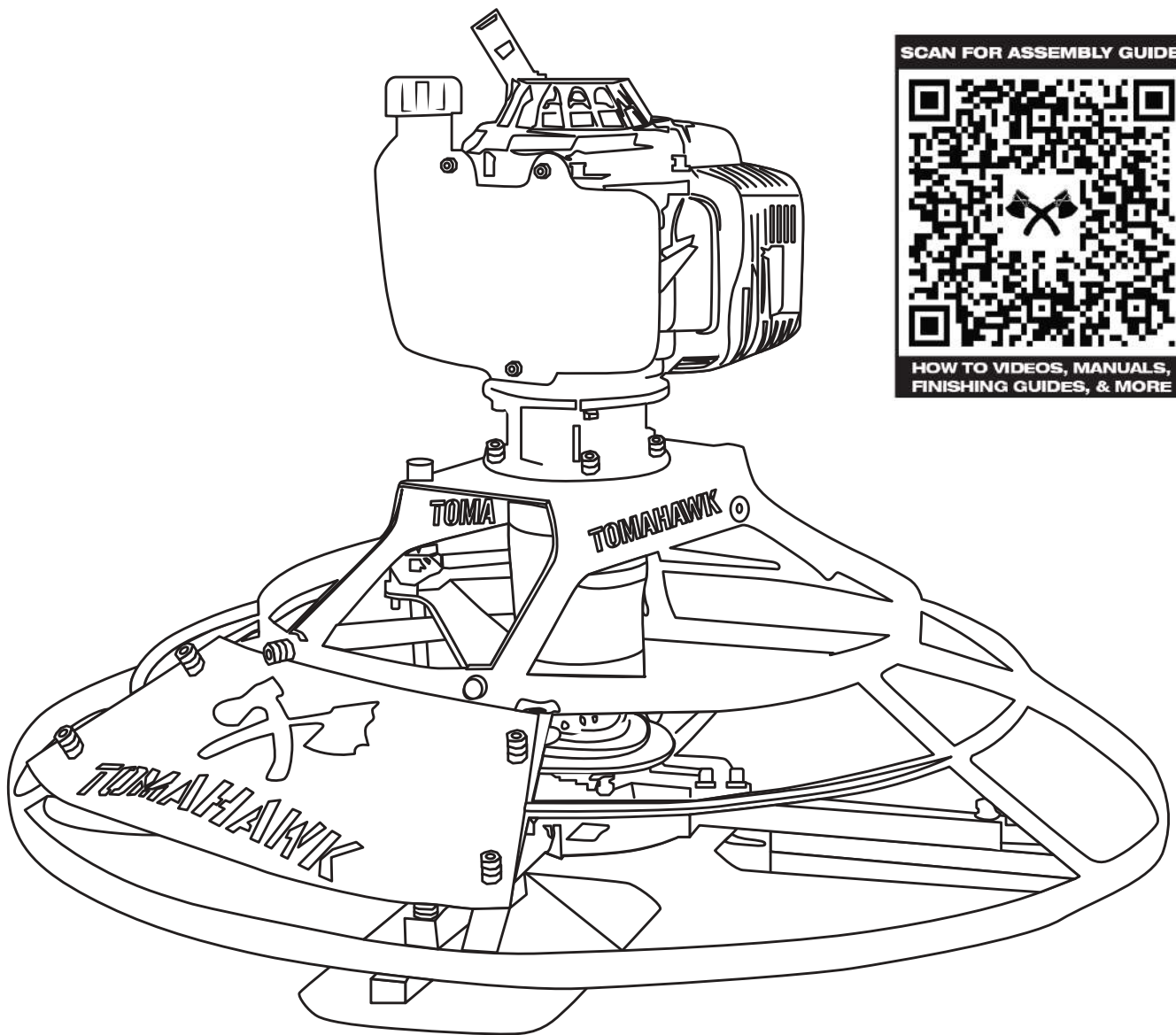

To reduce the risk of injury, the user must read and understand the Operator's Manual before using this product. Save these instructions for future reference.

TOMAHAWK

Table of Contents

1. SAFETY INFORMATION	4
1.1 Laws Pertaining to Spark Arresters	5
1.2 Operating Safety	5
1.3 Safety While Using Combustion Engines	6
1.4 Service Safety	6
2. GENERAL INFORMATION	7
2.1 Intended Use	7
2.2 Trowel Familiarization	7
3. TECHNICAL DATA	8
3.1 Specifications	8
3.2 Product Features	8
3.3 Parts Included	8
4. OPERATION	9
4.1 Before Operation	9
4.2 Connecting the Handles	9
4.3 Starting the Machine	10
4.4 Stopping the Machine	10
4.5 Using the Trowel	10
4.6 Pitching the Blades	11
4.7 Floating Operation	11
4.8 Finishing Operation	11
5. MAINTENANCE	12
6. STORAGE & CLEANING	13
7. ACCESSORY OPTIONS	14
9. TOMAHAWK CATALOG & COUPON	18

Register Your Equipment

Thank you for purchasing TOMAHAWK equipment! Your product is covered by the TOMAHAWK Warranty policy, but in order to activate your warranty, we need you to register your product. In addition to activating your equipment warranty, product registration will grant you access to important product updates, streamlined customer service and more.

INCLUDED WITH YOUR REGISTRATION

- ✓ Equipment Warranty Activation
- ✓ Product Updates
- ✓ Streamlined Customer Service
- ✓ Exclusive Discounts and Sales

STEPS TO REGISTER YOUR EQUIPMENT

1. Visit www.tomahawk-power.com
2. Choose “Product Registration” at the bottom of the page
3. Enter your equipment’s serial number to get started
4. Provide all required information
5. Submit Registration

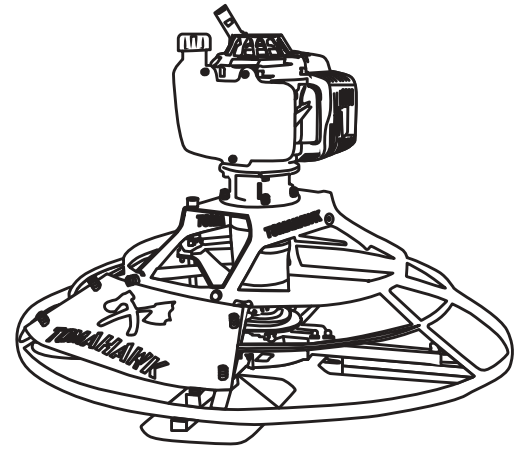

Equipment Resources

Tomahawk Customer Service doesn’t stop at checkout. We understand to keep a job-site running smoothly - the proper equipment, spare parts, instruction manuals, and more are needed at the drop of a hat. Visit www.tomahawk-power.com to gain access to the incredible resources below.

How To Video Library

More of a visual person? Visit our Video Library for equipment assembly instructions, troubleshooting tips, and more!

Found on each product listing or the Service Videos Page

Manual and Assembly Guide Library

Visit our Manual Library if you are looking for a lost operations manual or a particular spare part?

Found on each product listing or the Tomahawk Manuals Page

Service Requests

In need of a quick fix or a service center referral? Submit a Service Request and a Tomahawk Technician will respond shortly to get you the help you need.

Choose “Service Request” at the bottom of www.tomahawk-power.com



This manual provides information and procedures to safely operate and maintain this equipment. For your own safety and protection from injury, carefully read, understand and observe the safety instructions described in this manual.

Keep this manual or a copy of it with the equipment. If you lose this manual or need an additional copy, please contact Tomahawk Power LLC or visit www.tomahawk-power.com. This equipment is built with user safety in mind; however, it can present hazards if improperly operated and serviced. Follow operating instructions carefully. If you have questions about operating or servicing this equipment, contact Tomahawk Power.

The information contained in this manual is based on equipment's production at the time of publication. Tomahawk Power reserves the right to change any portion of this information without notice.

No part of this publication may be reproduced in any form or by any means, electronic or mechanical, including photocopying, without express written permission from Tomahawk Power.

Any type of reproduction or distribution not authorized by Tomahawk Power represents an infringement of valid copyrights and will be prosecuted. We expressly reserve the right to make technical modifications, even without due notice, which aim at improving our machines or their safety standards.

1. SAFETY INFORMATION

This manual contains DANGER, WARNING, CAUTION, and NOTE call-outs which must be followed to reduce the possibility of personal injury, damage to the equipment, or improper service.



This is the safety alert symbol. It is used to alert you to potential personal injury hazards. Obey all safety messages that follow this symbol to avoid possible injury or death.



DANGER indicates an imminently hazardous situation which, if not avoided, will result in death or serious injury.



WARNING indicates a potentially hazardous situation which, if not avoided, could result in death or serious injury.



CAUTION indicates a potentially hazardous situation which, if not avoided, may result in minor or moderate injury.

CAUTION: Used without the safety alert symbol, **CAUTION** indicates a potentially hazardous situation which, if not avoided, may result in property damage.

1.1 Laws Pertaining to Spark Arresters

Notice: State Health Safety Codes and Public Resources Codes specify that in certain locations spark arresters be used on internal combustion engines that use hydrocarbon fuels. A spark arrester is a device designed to prevent accidental discharge of sparks or flames from the engine exhaust. Spark arresters are qualified and rated by the United States Forest Service for this purpose.

In order to comply with local laws regarding spark arresters, consult the engine distributor or the local Health and Safety Administrator.

1.2 Operating Safety



WARNING

Familiarity and proper training are required for the safe operation of equipment! Equipment operated improperly or by untrained personnel can be dangerous! Read the operating instructions contained in both this manual and the engine manual and familiarize yourself with the location and proper use of all controls. Inexperienced operators should receive instruction from someone familiar with the equipment before being allowed to operate the machine.

1.2.1 NEVER allow anyone to operate this equipment without proper training. People operating this equipment must be familiar with the risks and hazards associated with it.

1.2.2 NEVER touch the engine or muffler while the engine is on or immediately after it has been turned off. These areas get hot and may cause burns.

1.2.3 NEVER use accessories or attachments that are not recommended by Tomahawk Power. Damage to equipment and injury to the user may result.

1.2.4 NEVER leave machine running unattended.

1.2.5 ALWAYS be sure operator is familiar with proper safety precautions and operation techniques before using machine.

1.2.6 ALWAYS wear ANSI Z87.1-approved safety goggles or safety glasses with side shields, or when needed, a face shield. Use a dust mask in dusty work conditions. Also use non-skid safety shoes, hardhat, gloves, dust collection systems, and hearing protection when appropriate. This applies to all persons in the work area.

1.2.7 ALWAYS close fuel valve on engines equipped with one when machine is not being operated.

1.2.8 ALWAYS store equipment properly when it is not being used. Equipment should be stored in a clean, dry location out of the reach of children.

1.2.9 ALWAYS operate machine with all safety devices and guards in place and in working order. DO NOT modify or remove safety devices. DO NOT operate machine if any safety devices or guards are missing or inoperative.

1.2.10 ALWAYS read, understand, and follow procedures in Operator's Manual before attempting to operate equipment.

1.3 Safety while using Combustion Engines



DANGER Internal combustion engines present special hazards during operation and fueling! Read and follow warning instructions in engine owner's manual and safety guidelines below. Failure to follow warnings and **DANGER** safety guidelines could result in severe injury or death.

1.3.1 DO NOT run machine indoors or in an enclosed area such as a deep trenches unless there is adequate ventilation, through such items as exhaust fans or hoses are provided. Gasoline exhaust from the engine contains poisonous carbon monoxide gas; exposure to carbon monoxide can cause loss of consciousness and may lead to death.

1.3.2 DO NOT smoke while operating machine.

1.3.3 DO NOT smoke when refueling engine.

1.3.4 DO NOT refuel hot or running engine.

1.3.5 DO NOT refuel engine near open flame.

1.3.6 DO NOT spill fuel when refueling engine.

1.3.7 DO NOT run engine near open flames.

1.3.8 ALWAYS refill fuel tank in well-ventilated area.

1.3.9 ALWAYS replace fuel tank cap after refueling.

1.3.10 ALWAYS check fuel lines and fuel tank for leaks and cracks before starting engine.

1.3.11 DO NOT run machine if fuel leaks are present or fuel lines are loose.

1.4 Service Safety



WARNING Poorly maintained equipment can become a safety hazard! In order for the equipment to operate safely and properly over a long period of time, periodic maintenance and occasional repairs are necessary.

1.4.1 DO NOT attempt to clean or service machine while it is running. Rotating parts can cause severe injury.

1.4.2 DO NOT crank a flooded engine with the spark plug removed on gasoline-powered engines. Fuel trapped in the cylinder will squirt out the spark plug opening.

1.4.3 DO NOT test for spark on gasoline-powered engines, if engine is flooded or the smell of gasoline is present. A stray spark could ignite fumes.

1.4.4 DO NOT use gasoline or other types of fuels or flammable solvents to clean parts, especially in enclosed areas. Fumes from fuels and solvents can become explosive.

1.4.5 ALWAYS keep area around muffler free of debris such as leaves, paper, cartons, etc. A hot muffler could ignite them, starting a fire.

1.4.6 ALWAYS replace worn or damaged components with spare parts designed and recommended by Tomahawk Power.

1.4.7 ALWAYS disconnect spark plug on machines equipped with gasoline engines, before servicing, to avoid accidental start-up.

1.4.8 ALWAYS keep machine clean and labels legible. Replace all missing and hard-to-read labels. Labels provide important operating instructions and warn of dangers and hazards.

1.4.9 ALWAYS check for damaged parts before each use. Carefully check that the trowel will operate properly and perform its intended function. Replace damaged or worn parts immediately. Never operate the trowel with a damaged part.

1.4.10 ALWAYS inspect the machine prior to placing in storage and before re-use. Store the trowel in a dry, secure place out of the reach of children when not in use.

1.4.11 ALWAYS use only accessories that are recommended by the manufacturer for use with the trowel . Accessories that may be suitable for one trowel may create a risk of injury when used with the equipment.

1.4.12 ALWAYS keep blades clean when not in use and guards in place and in working order.

2. GENERAL INFORMATION

2.1 Intended Use

Leave laborious hand-finishing tasks in the past with the Tomahawk Porta Trowels! Densify concrete floors with ease for your ideal finishing results on projects including driveways, footpaths, tilt/precast concrete panels, residential foundations, and more!

2.2 Trowel Familiarization

Tomahawk Power Trowels are designed for the floating and finishing of concrete slabs. Analyze your trowel and take notice of each component: the engine, blades, air filter, centrifugal stop switch, clutch and pulley system. Be sure that there is always oil in the engine.

2.3 Engine

Tomahawk Power Porta Trowels are powered by Tomahawk Engines. For further assistance or to receive a new manual, contact Tomahawk Power customer service at (866) 577-4476 or refer to the Manuals Page on the Tomahawk Power website.

2.4 Guard Ring

Avoid placing your hands or feet within the guard ring while the engine is in operation. Exercise caution when using the Tomahawk PortaTrowel. Never operate with the Tomahawk PortaTrowel a damaged guard ring or wit the guard ring removed.

2.5 Blade Pitch Control

Rotate the handle in a clockwise direction to raise the blade pitch, and in a counter-clockwise direction to lower it.

2.6 ON/OFF Switch

ON/OFF Switch is conveniently located for easy access.

2.7 Handle

The Tomahawk PortaTrowel handle consists of multiple clip-together handles. The number of handles joined together should be limited to three, as exceeding this limit will result in reduced control of the unit. It is essential to adjust the handle length according to the specific requirements of each job.

2.8 Throttle Control

Adjust the lever downward to increase the engine speed and upward to decrease it.

2.9 Gearbox

The gearbox transfers power from the engine to the spider. Ensure that no debris accumulates on the gearbox and clean it regularly to prevent overheating.

2.10 Spider Plate and Trowel Arm

These components enable blade rotation and smooth operation. After each use, it is crucial to clean and maintain the spider plates and trowel arms to prevent uneven blade wear on the concrete surface.

2.11 Combination Blades

Concrete trowel combination blades are specialized tools used in concrete finishing and smoothing processes. They typically consist of multiple blades attached to a trowel machine or power trowel. These blades are designed to achieve a smooth and level concrete surface by effectively troweling and finishing the concrete.

3. TECHNICAL DATA

3.1 Specifications

Engine	Tomahawk 4 Stroke
Power	37.7cc
Blade Speed	40 - 70 RPM
Rotor Diameter	30" (76.2cm)
Blade Pitch	0-28°

Blades Included	4
Handles Included	4 (4ft/1.2m Each)
Fuel Type	SAE 10W30
Oil Type	89 Octane
Weight	56 lbs (25.4 kg)

3.2 Product Features

Make Flat Work Less Work with TOMAHAWK® Portable Trowels – leaving laborious hand-finishing tasks in the past! Easy to store, transport, and use, Tomahawk Portable Trowels are a game-changer in concrete finishing. Weighing less than 60 lbs (27.2 kg) assembly is a breeze – simply connect up to three handles matching your slab size. No need to wait! The trowel's compact, lightweight design allows concrete finishing up to 45 minutes earlier, while you work up to 20ft (6m) outside the formwork!

3.3 Parts Included

- A) Trowel
- B) Handles
- C) Throttle Kit
- D) Four 4ft Poles

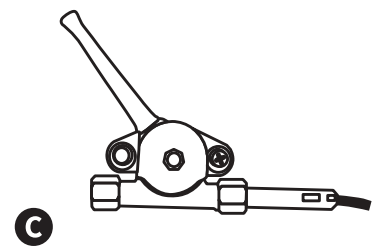
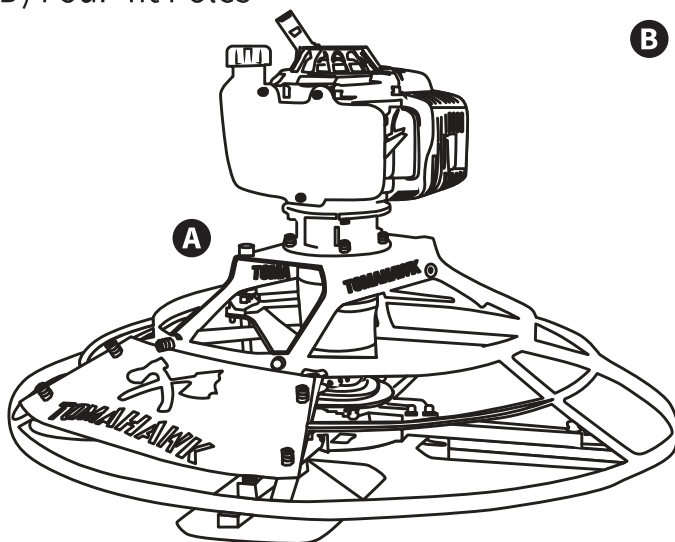

4. OPERATION

4.1 Before Operation

Before using the Tomahawk PortaTrowel, it is essential to perform a daily inspection of the following parts.

- Engine Fuel is 89 Octane
- Oil Level with SAE10W-30 4-Stroke Oil
- Blade condition and pitch control operation
- Proper assembly of handles

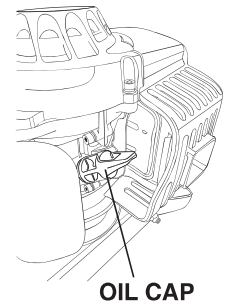
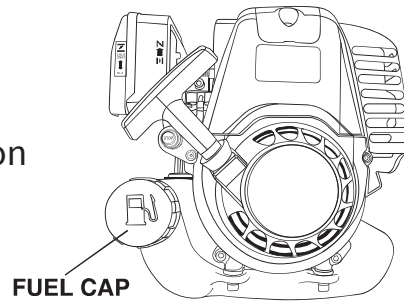

4.2 Connecting the Handles

The Tomahawk PortaTrowel is compatible exclusively with Tomahawk 4ft Clip-Together Handles.

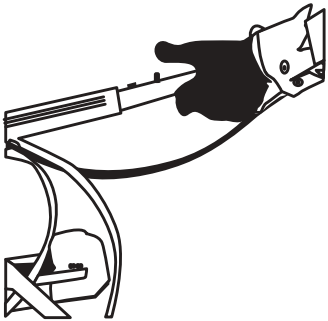

1 Locate the handles with the two holes meant to attach the throttle. Insert the silver end of the handle, featuring the push button locking pin, into the handle slot of the trowel. Ensure that it is properly inserted and locked into position.

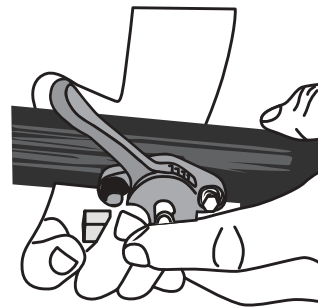

2 Connect the throttle by placing two rubber washers over the screws, then insert the screws into the right side of the pole.

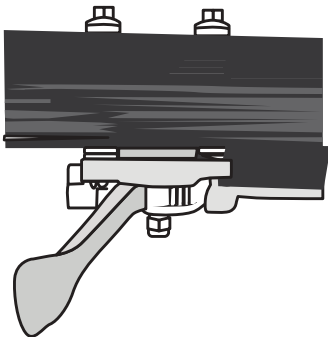

3 Add the remaining rubber washers, metal washers, and nuts to the end of the screws and fasten tightly using an 8mm wrench and phillips head screw driver.

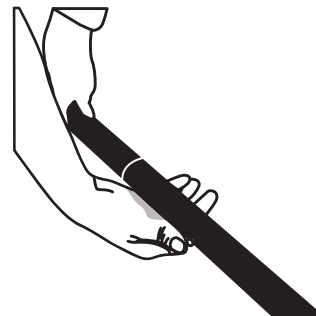

4 Connect the additional 4ft clip-together poles as needed. If this is your first time using the machine, Tomahawk suggests starting with 1-2 poles until you are comfortable operating the machine.

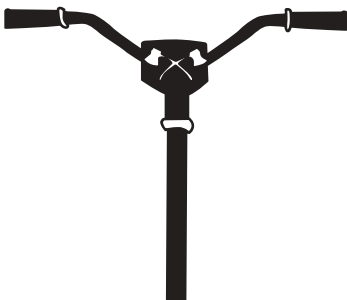

OPTIONAL

The trowel's handles add extra operator stability & comfort during operation, however they are not necessary to operate the machine, if you choose to use 1-2 poles.

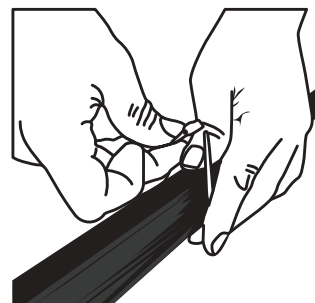

OPTIONAL

Tie down the throttle cable with a zip-]tie to prevent damage or dragging.

4.3 Starting the Machine

Perform the following steps to start the engine and begin troweling:

4.3.1 To start a cold engine, move the choke lever (Figure 1) to the CLOSED position. If restarting a warm engine leave the choke lever in the OPEN position.

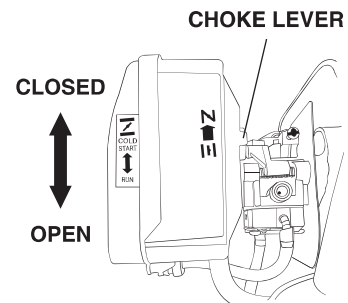

Figure 1

4.3.2 Press the priming bulb (Figure 2) repeatedly until fuel can be seen inside the fuel lines.

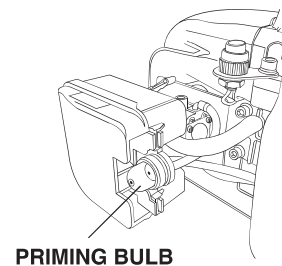

Figure 2

4.3.3 Move the throttle lever slightly to give the engine some speed.

4.3.4 Pull the starter rope (Figure 3) lightly until you feel resistance, then pull briskly in the direction of the arrow. Return the starter rope gently.

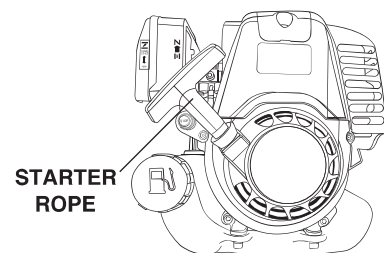

Figure 3

4.3.5 Once the engine has started, open the choke and allow engine to idle for 3 to 5 minutes to warm-up.

4.4 Stopping the Machine

To stop the machine, press the red engine stop button, to the left of the engine's recoil starter

RED ENGINE
STOP BUTTON

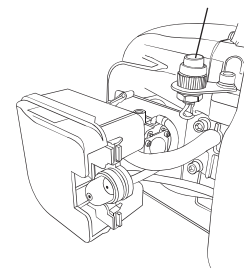

Figure 4

4.5 Using the Trowel

4.4.1 To maneuver the trowel in a forward and backward motion, push the handle away from your body and then pull it back towards you, similar to how you would handle a bull float.

4.4.2 To move the trowel from left or right, gently adjust the handle upward or downward using a slow and gentle motion.

4.6 Pitching the Blades

4.5.1 To pitch the blades upwards, turn the handle clockwise.

4.5.2 To lay the blades flat, turn the handle counter-clockwise.

4.5.3 The trowel's pitch adjustment feature enables swift and precise changes in the blade angle, eliminating the need to switch blade types during a job to accommodate different surface conditions on the slab. This capability allows the operator to work more efficiently, resulting in faster progress and a superior finish on the slab.

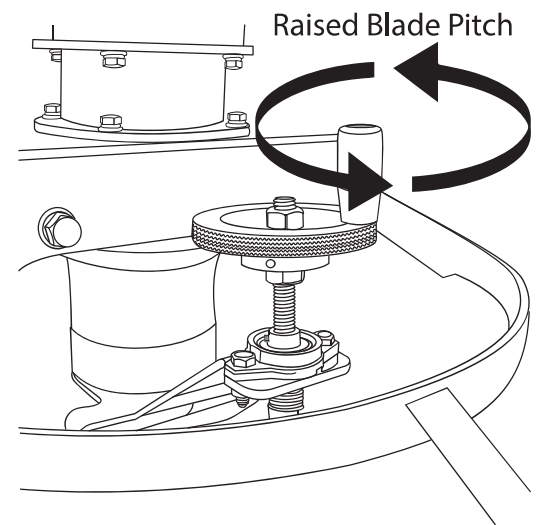

Avoid allowing the machine to remain stationary in a single spot on soft concrete. Once the floating operation is finished, lift the trowel from the slab surface.

4.7 Floating Operation

For optimal floating performance, it is advisable to maintain the trowel blades in a level position while operating between $\frac{1}{2}$ to $\frac{3}{4}$ of the maximum speed. Each pass should overlap the previous one by half the width of the trowel.

To achieve the desired finish, an additional trowel pass may be necessary. For this pass, it is recommended to use a crossover floating technique, adjusting the blade pitch slightly higher and operate the trowel at approximately $\frac{3}{4}$ of the maximum speed. Once the floated slab has adequately set, it is ready for the finishing process.

4.8 Finishing Operation

To achieve the desired concrete surface finish, the operator should make adjustments to the blade pitch, taking into account the hardness or plasticity of the concrete. For wet or plastic concrete, begin with the blades positioned flat or at a slight angle on the surface. As the concrete adequately hardens, increase the blade pitch while considering the concrete hardness and the desired finish. Regularly assess the achieved concrete finish and modify the blade pitch accordingly. Generally, a greater blade pitch results in a smoother finish, but excessive pitch can lead to accelerated blade wear.

To fix a hole or reduce a hump, move the trowel back and forth over the area. Additional passes may be necessary to achieve the desired surface finish.

5. MAINTENANCE

Maintain the trowel in accordance with the following recommended procedures. Refer to the engine manufacturer's instruction manual for additional information about engine maintenance. The following chart is based on a normal operation schedule.

	DAILY BEFORE STARTING	AFTER FIRST 20 HOURS OR 3 MONTHS	AFTER FIRST 50 HOURS OR 6 MONTHS	AFTER FIRST 100 HOURS OR EVERY YEAR	AFTER FIRST 200 HOURS OR EVERY 2 YEARS
Check the fuel level	●				
Check the engine oil level	●				
Inspect the fuel lines	●				
Inspect the air filter and replace if needed	●				
Check and tighten the external hardware	●				
Change the engine oil		●			
Clean the air filter			●		
Change the engine oil			●		
Check and clean the spark plug			●		
Clean the fuel strainer				●	
Check and adjust the valve clearance					●
Clean the cylinder head					●
Replace the spark plug					●

6. STORAGE AND CLEANING

6.1 Cleaning

Keep the unit clean and free from concrete build up.

6.2 Storage

Clean the Engine: Thoroughly clean the exterior of the engine to remove any dirt, debris, or grime. This helps prevent corrosion and ensures a clean storage environment.

Change the Oil: Replace the engine oil with a fresh one. Used oil may contain contaminants that can cause damage during storage. Follow the manufacturer's recommendations for the correct oil type and change procedure.

Stabilize the Fuel: Add a fuel stabilizer to the gas tank and run the engine for a few minutes to allow the treated fuel to circulate through the system. This prevents the fuel from deteriorating and causing issues when starting the engine later.

Empty the Fuel Tank: If the engine will be stored for an extended period (more than a few months), it's advisable to drain the fuel tank completely. Storing the engine with fuel can lead to fuel degradation and carburetor problems.

Run the Engine: Start the engine and allow it to run for a few minutes. This helps distribute the stabilized fuel throughout the system and prevents the formation of deposits.

Remove the Spark Plug: Remove the spark plug and add a small amount of engine oil (about one tablespoon) into the spark plug hole. Slowly pull the starter cord a few times to distribute the oil inside the cylinder. This helps prevent rust formation during storage.

Clean or Replace the Air Filter: Check the air filter and clean it if necessary. A clean air filter ensures proper airflow and prevents debris from entering the engine during storage.

Store in a Dry and Covered Area: Find a dry and well-ventilated storage area to protect the engine from moisture and dust. Use a cover to shield it from direct sunlight and potential damage.

Battery Maintenance: If the engine has a battery, remove it and store it separately in a cool, dry place. Regularly charge the battery according to the manufacturer's instructions to maintain its health during storage.

Periodic Inspection: While the engine is in storage, periodically inspect it for any signs of damage, corrosion, or pests. This allows for early detection and timely maintenance if required.

7. ACCESSORY OPTIONS

7.1 Blades



Blades should be changed when they fail to finish concrete in a satisfactory manner.

Blades are a vital part of finishing concrete. This Tomahawk Trowel has been designed to finish concrete and is built to stringent quality standards out of the finest trowel steel. If you need replacement blades, consult your parts list in this manual for part numbers and order them from the Tomahawk Website or your Tomahawk parts dealer.

7.2 Combo Blades

This trowel was equipped with combination FLOAT/FINISH (Figure 15) blades as original equipment. These blades have been designed for optimum performance in both the floating and finishing operations. These blades are versatile and should take care of most troweling needs.

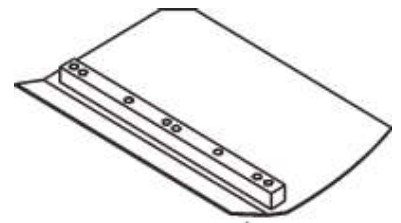

FIGURE 15

7.3 Finishing Blades (Optional)

These blades have been specifically designed for finish operations with this trowel. They will provide a premium surface finishing capability from your trowel. They should only be used after the concrete has set to the point where the trowel does not sink into the concrete when placed on it.

7.4 Clip-On Float Blades (Optional)

These blades will clip (Figure 16) on to an existing installed blade, allowing your finisher to float on “wet” concrete so that the troweling operation can begin as early as possible. They are easily removable, so that after the floating operation, when the concrete is sufficiently cured, they can be removed to expose the finish blades for continued troweling.

7.5 Float Pans (Optional)

These round discs attach to the spiders and allow the machine to “float” on “wet” concrete. The disc design allows early floating and easy movement from wet to dry areas. They are also very effective in embedding large aggregates and surface hardeners.

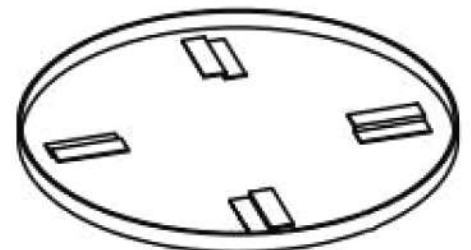

FIGURE 16



FAST TRACK YOUR CONCRETE JOB

Master your next concrete job with Tomahawk Concrete Power Screeds! Bundle & Save when choosing blades from 4ft-16ft helping you increase crew speed and jobsite efficiency!



Item #: TVSA-T, TVSA-H, eTVSA

VIBRATORY CONCRETE POWER SCREEDS

www.tomahawk-power.com





NEVER PUMP NEVER LOSE PRESSURE

Lose the manual pump and gain the power to spray **15,000 ft² in 10 minutes** or less while maintaining constant, adjustable pressure from 50-435 PSI with your ideal concrete sealant, cure, top cast, form release, and more!



Item #: TCS6.5

6.5 GAL MOTORIZED CONCRETE SPRAYER

www.tomahawk-power.com 





CUT CONCRETE FASTER

Tomahawk Green Concrete Saws cut contraction joints up to 1-3/16th inches deep - within the first 1-2 hours of finishing, to control stress cracking for the ultimate concrete results! Powered by the concrete industry's trusted Honda GX Series Engines, maintain clean cuts, while keeping debris out!

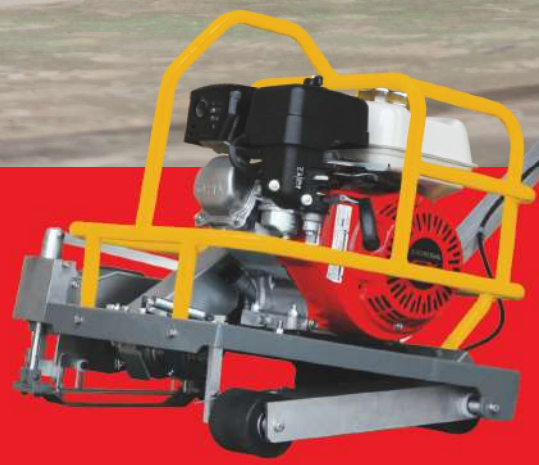

Item #: TFS6H

**6" EARLY ENTRY
GREEN CONCRETE SAW**

www.tomahawk-power.com 

TOMAHAWK

PRODUCT CATALOG

COMPACTION



HONDA
ENGINES

3,550 lbs/ft Vibratory Rammer
Part#: TR68H

3.6 HP Honda GXR120 Engine
Easily achieve a 100% compaction rating
3-in-One Fuel System with carburetor protection
13" x 11" plate for narrow trenches and corners
3 Year Engine Warranty & 1 Year Product Warranty



HONDA
ENGINES

3,400 lbs/ft Plate Compactor
Part#: TPC90H

5.5 HP Honda GX160 Engine
Easily achieve a 100% compaction rating
22" x 20" cold, rolled steel beveled base plate
Includes 3.5 gallon water tank for asphalt compaction
3 Year Engine Warranty & 1 Year Product Warranty



HONDA
ENGINES

KOHLER
ENGINES

3,000 lbs/ft Plate Compactor
Part#: TPC80 & TPC80H

6 HP Kohler CH260 & 5.5 HP Honda GX160 Engines
Easily achieve a 100% compaction rating
16.5" x 21.5" plate for narrow trenches and corners
Optional Honda Engine model: TPC80H
3 Year Engine Warranty & 1 Year Product Warranty

FINISHING



6.5 Gal Backpack Concrete Sprayer
Part#: TCS6.5

Maintain constant, adjustable pressure up to 450 PSI
Achieve superior concrete finishes with even spraying
Spray 15,000 sq ft in less than 10 minutes
Compatible with major manufacturer wands
1 Year Product Warranty



HONDA
ENGINES

1.6 HP Vibratory Concrete Screed
Part#: TVSA-H

1.6 HP Honda GX35 Engine
Aluminum Magnesium blades available from 8ft - 14ft
Finish concrete 4X faster than other screed methods
360° adjustable handle placement
3 Year Engine Warranty & 1 Year Product Warranty



HONDA
ENGINES

6" Early Entry Green Concrete Saw
Part#: TFS6H

5.5 HP Honda GX160 Engine
Maximum cutting depth of 1 3/16 inches
OSHA compliant vacuum port for dust collection
Includes 6" early entry concrete blade
3 Year Engine Warranty & 1 Year Product Warranty

FINISHING



HONDA
ENGINES

1.6HP Backpack Concrete Vibrator
Part#: TVIBH + TVW10-P

1.6 HP Honda GX35 engine
Consolidation with speeds of 10,000-12,000 VPM
Quick Connect centrifugal clutch vibrator
1" and 2" Diameter Whips Available in 10ft Length
3 Year Engine Warranty & 1 Year Product Warranty

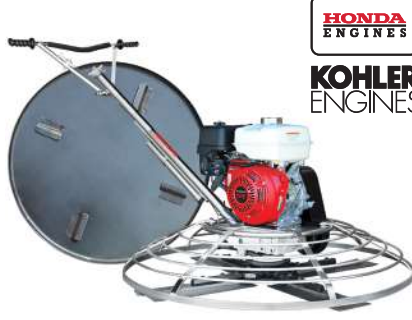

HONDA
ENGINES

KOHLER
ENGINES

36" & 46" Concrete Power Trowel
Part#: TPT36H/K & TPT46H/K

6 HP/14HP Kohler & 5.5HP/8.5HP Honda Engines
Adjust trowel blade pitch from 0-28°
60-115 RPM rotor speed for superior concrete finishes
Includes float pan and trowel blades
3 Year Engine Warranty & 1 Year Product Warranty



HONDA
ENGINES

8" Gas Powered Concrete Scarifier
Part#: TSCAR8H

5.5 HP Honda GX160 Engine
Remove traffic lines at 800 - 1,000 linear ft/hr
Tungsten Carbide Blade Kit Available
OSHA approved dust port for silica vacuum removal
3 Year Engine Warranty & 1 Year Product Warranty

HAVE QUESTIONS?

Contact us. *We're here to help!*

Email us at sales@tomahawk-power.com



USE CODE

SAVE10

AT CHECKOUT FOR

10% OFF YOUR ORDER AT

WWW.TOMAHAWK-POWER.COM

POWER / WELDING

INVERTER SERIES



2000 Watt Inverter Generator
Part#: TG2000I

2000 Max Watts, 1600 Rated Watts
Run Time of 8 hours on 1 gallon of gas
OSHA and GFCI Compliant
Parallel technology capable for double the power
2 Year Product Warranty

INVERTER SERIES



210 Amp Portable Welder Generator
Part#: TWG210A

Steady 50 - 210 Amp DC welding output
60% Duty Cycle for extended use
Suitable for welding rods from 6010 to 7024
Electric Key Start with battery included
2 Year Product Warranty



7000 Watt Generators
Part#: TG7000

7000 Max Watts, 5500 Rated Watts
Voltage Selector gives Full Wattage for 120V or 240V
Run Time of 8 hours at 50% Load
OSHA and GFCI Compliant
2 Year Product Warranty

PEST CONTROL



3.7 Gallon 3HP Backpack Fogger
Part#: TMD14

Turbo Boosted Pump with 40ft + Horizontal Reach
Sprays 1 acre in 30 minutes
10X Faster than Manual Pump Sprayers
Converts to Leaf Blower with 200 MPH Air Velocity
1 Year Product Warranty



4.75 Gallon Battery Power Sprayer
Part#: eTPS18

Reach Up to 30ft Horizontal Reach
Sprays 6000 sq ft in 10 minutes
10X Faster than Manual Pump Sprayers
70 PSI Commercial Grade Pump
1 Year Product Warranty



5 Gallon Backpack Power Sprayer
Part#: TPS25

Reach Up to 30ft Horizontal Reach
Sprays acres in 10 minutes
10X Faster than Manual Pump Sprayers
50-435 Adjustable PSI Commercial Grade Pump
1 Year Product Warranty

AND MORE



4 Gal. Backpack Fertilizer Spreader
Part#: TGS30

Reach up to 30ft Horizontally
Sprays 1 acre in 30 minutes
20X Faster than push spreaders
Converts to Leaf Blower with 200 MPH Air Velocity
1 Year Product Warranty



3" Full Trash Water Pump
Part#: TW3H

Moves liquids at a rate up to 375 gal/min
Handle solids up to 1.5"
Silicone carbide seals and a chrome plated volute
8 HP engine protected by rugged all purpose frame
3 Year Engine Warranty & 1 Year Product Warranty



Commercial 38" Push Sweeper
Part#: TOS38

Collect up to 14.5 gallons of dust and debris
Can be used indoors & outdoors on wet or dry surfaces
Includes integrated airflow control and fine dust filter
Lightweight design, capable of fitting through doorways
1 Year Product Warranty



* All coupons in this manual are valid only for orders placed on www.tomahawk-power.com, unless otherwise noted. Coupon codes may only be used once per customer and may not be combined with any other offer. Coupons may expire at any time without notice.

(866) 577-4476

WWW.TOMAHAWK-POWER.COM



POWER YOUR WORLD

Tomahawk understands to keep a job-site running smoothly the proper equipment and spare parts are needed at the drop of a hat. With same day shipping and faster delivery times, count on Tomahawk to keep you powered throughout the day! With long lasting parts and engines, Tomahawk equipment will be the star of your fleet for years to come. Visit www.tomahawk-power.com to get started today!

Tomahawk Power, LLC
San Diego, CA

Sales Support
(866) 577-4476
sales@tomahawk-power.com

Equipment Support
(866) 577-4476
support@tomahawk-power.com

www.tomahawk-power.com



FACEBOOK
facebook.com/TomahawkPowerUSA

YOUTUBE
youtube.com/TomahawkPower

INSTAGRAM
[@tomahawkpower](https://instagram.com/tomahawkpower)