

# Operation and Instruction Manual

# JUMPING JACK

***MODEL: JXPC50H / JXPC50K***

**FORWARD PLATE COMPACTOR**

**(Honda Gasoline Engine)  
(Kohler Gasoline Engine)**

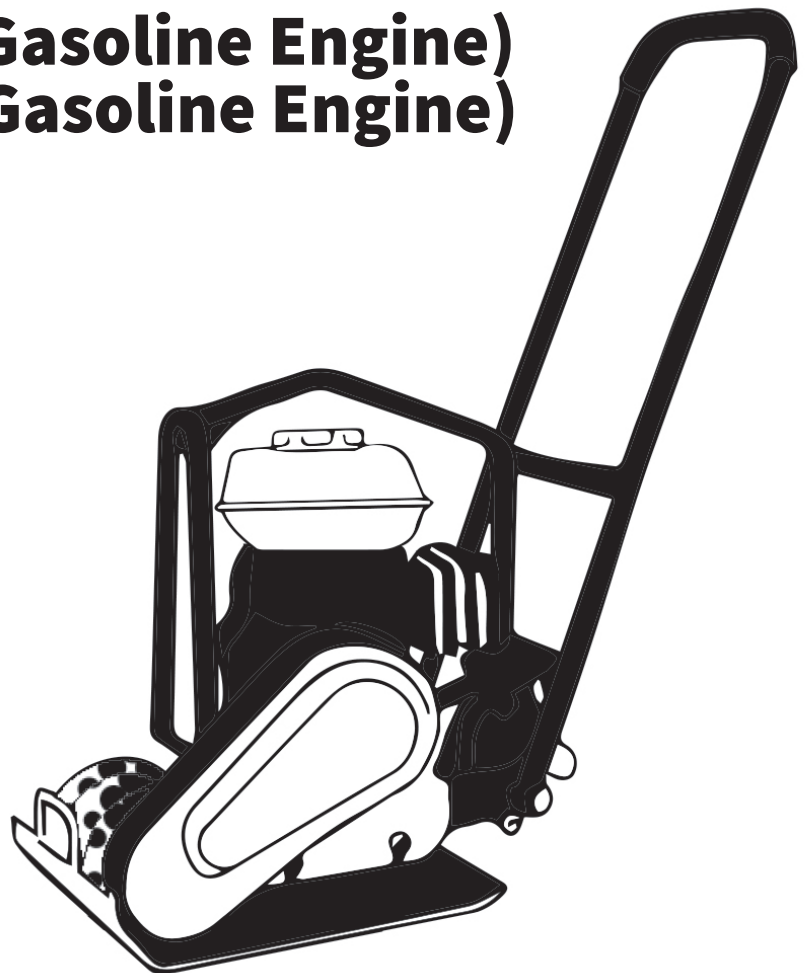

# Table of Contents

<b>1. Safety Information</b> .....	4
1.1 Laws Pertaining to Spark Arresters .....	5
1.2 Operating Safety .....	5
1.3 Operator Safety while using Gasoline Engines .....	7
1.4 Service Safety .....	7
<b>2. Technical Data</b> .....	7
2.1 Engine Data .....	7
2.2 Machine Data .....	7
<b>3. Operation</b> .....	8
3.1 Recommended Fuel .....	8
3.2 Before Starting .....	8
3.3 To Start .....	9
3.4 To Stop .....	10
3.5 Application .....	10
3.6 Operation .....	10
<b>4. Maintenance</b> .....	11
4.1 Periodic Maintenance Schedule .....	11
4.2 Cleaning Plate .....	11
4.3 Drive Belt .....	12
4.4 Exciter Lubrication .....	12
4.5 Spark Plug .....	13
4.6 Engine Oil .....	14
4.7 Air Cleaner .....	15
4.8 Cleaning Sediment Cup .....	15
4.9 Carburetor Adjustment .....	16
4.10 Troubleshooting .....	17
4.11 Storage .....	17
4.12 Lifting Machine .....	18
4.13 Transporting the Machine .....	18

<b>5. Compaction Tips</b>	19
5.1 Soil Drop Test	19
5.2 Soil Testing	19
5.3 Compaction Terms	20
<b>6. Spare Parts Manual</b>	22

This manual provides information and procedures to safely operate and maintain this model. For your own safety and protection from injury, carefully read, understand and observe the safety instructions described in this manual.

Keep this manual or a copy of it with the machine. If you lose this manual or need an additional copy, please contact JUMPING JACK or call 866-577-4476 This machine is built with user safety in mind; however, it can present hazards if improperly operated and serviced. Follow operating instructions carefully. If you have questions about operating or servicing this equipment, please contact JUMPING JACK.

The information contained in this manual is based on machines in production at the time of publication. JUMPING JACK reserves the right to change any portion of this information without notice.

No part of this publication may be reproduced in any form or by any means, electronic or mechanical, including photocopying, without express written permission from JUMPING JACK.

Any type of reproduction or distribution not authorized by JUMPING JACK represents an infringement of valid copyrights and will be prosecuted. We expressly reserve the right to make technical modifications, even without due notice, which aim at improving our machines or their safety standards.

## 1. Safety Information

This manual contains DANGER, WARNING, CAUTION, and NOTE callouts which must be followed to reduce the possibility of personal injury, damage to the equipment, or improper service.



This is the safety alert symbol. It is used to alert you to potential personal injury hazards. Obey all safety messages that follow this symbol to avoid possible injury or death.



DANGER

DANGER indicates an imminently hazardous situation which, if not avoided, will result in death or serious injury.



WARNING

WARNING indicates a potentially hazardous situation which, if not avoided, could result in death or serious injury.



CAUTION

CAUTION indicates a potentially hazardous situation which, if not avoided, may result in minor or moderate injury.

**CAUTION:** Used without the safety alert symbol, CAUTION indicates a potentially hazardous situation which, if not avoided, may result in property damage.

## 1.1 Laws Pertaining to Spark Arresters

Notice: State Health Safety Codes and Public Resources Codes specify that in certain locations spark arresters be used on internal combustion engines that use hydrocarbon fuels. A spark arrester is a device designed to prevent accidental discharge of sparks or flames from the engine exhaust. Spark arresters are qualified and rated by the United States Forest Service for this purpose.

In order to comply with local laws regarding spark arresters, consult the engine distributor or the local Health and Safety Administrator.

## 1.2 Operating Safety



Familiarity and proper training are required for the safe operation of equipment! Equipment operated improperly or by untrained personnel can be dangerous! Read the operating instructions contained in both this manual and the engine manual and familiarize yourself with the location and proper use of all controls. Inexperienced operators should receive instruction from someone familiar with the equipment before being allowed to operate the machine.

1.2.1 **NEVER** allow anyone to operate this equipment without proper training. People operating this equipment must be familiar with the risks and hazards associated with it.

1.2.2 **NEVER** touch the engine or muffler while the engine is on or immediately after it has been turned off. These areas get hot and may cause burns.

1.2.3 **NEVER** use accessories or attachments that are not recommended by JUMPING JACK. Damage to equipment and injury to the user may result.

1.2.4 **NEVER** operate the machine with the beltguard missing. Exposed drive belt and pulleys create potentially dangerous hazards that can cause serious injuries.

1.2.5 **NEVER** leave machine running unattended.

1.2.6 **ALWAYS** be sure operator is familiar with proper safety precautions and operation techniques before using machine.

1.2.7 **ALWAYS** wear hearing protection when operating equipment.

1.2.8 **ALWAYS** wear protective clothing appropriate to the job site when operating equipment.

1.2.9 **ALWAYS** wear hearing protection when operating equipment.

1.2.10 **ALWAYS** close fuel valve on engines equipped with one when machine is not being operated.

1.2.11 **ALWAYS** store equipment properly when it is not being used. Equipment should be stored in a clean, dry location out of the reach of children.

1.2.12 **ALWAYS** operate machine with all safety devices and guards in place and in working order. **DO NOT** modify or remove safety devices. **DO NOT** operate machine if any safety devices or guards are missing or inoperative.

1.2.13 **ALWAYS** read, understand, and follow procedures in Operator's Manual before attempting to operate equipment.

### 1.3 Operator Safety while using Internal Combustion Engines



Internal combustion engines present special hazards during operation and fueling! Read and follow warning instructions in engine owner's manual and safety guidelines below. Failure to follow warnings and **DANGER** safety guidelines could result in severe injury or death.

1.3.1 **DO NOT** run machine indoors or in an enclosed area such as a deep trench unless adequate ventilation, through such items as exhaust fans or hoses is provided. Exhaust gas from the engine contains poisonous carbon monoxide gas; exposure to carbon monoxide can cause loss of consciousness and may lead to death.

1.3.2 **DO NOT** smoke while operating machine.

1.3.3 **DO NOT** smoke when refueling engine.

1.3.4 **DO NOT** refuel hot or running engine.

1.3.5 **DO NOT** refuel engine near open flame.

1.3.6 **DO NOT** spill fuel when refueling engine.

1.3.7 **DO NOT** run engine near open flames.

1.3.8 **ALWAYS** refill fuel tank in well-ventilated area.

1.3.9 **ALWAYS** replace fuel tank cap after refueling.

1.3.10 **ALWAYS** check fuel lines and fuel tank for leaks and cracks before starting engine.

1.3.11 **DO NOT** run machine if fuel leaks are present or fuel lines are loose.

### 1.4 Service Safety



Poorly maintained equipment can become a safety hazard! In order for the equipment to operate safely and properly over a long period of time, periodic maintenance and occasional repairs are necessary.

1.4.1 **DO NOT** attempt to clean or service machine while it is running. Rotating parts can cause severe injury.

1.4.2 **DO NOT** crank a flooded engine with the spark plug removed on gasoline-powered engines. Fuel trapped in the cylinder will squirt out the spark plug opening.

1.4.3 **DO NOT** test for spark on gasoline-powered engines, if engine is flooded or the smell of gasoline is present. A stray spark could ignite fumes.

1.4.4 **DO NOT** use gasoline or other types of fuels or flammable solvents to clean parts, especially in enclosed areas. Fumes from fuels and solvents can become explosive.

1.4.5 **ALWAYS** keep area around muffler free of debris such as leaves, paper, cartons, etc. A hot muffler could ignite them, starting a fire.

1.4.6 **ALWAYS** replace worn or damaged components with spare parts designed and recommended by JUMPING JACK.

1.4.7 **ALWAYS** disconnect spark plug on machines equipped with gasoline engines, before servicing, to avoid accidental start-up.

1.4.8 **ALWAYS** keep machine clean and labels legible. Replace all missing and hard-to-read labels. Labels provide important operating instructions and warn of dangers and hazards.

## 2. Technical Data

### 2.1 Engine Data

Model	JXPC50H	JXPC50K
Engine Type	Honda GX160	Kohler CH255
Power	5.5 HP (4 kw)	5.5 HP (4 kw)
Weight	110 lbs (54 kg)	110 lbs (54 kg)
Frequency	5900 VPM	5900 VPM
Compaction Depth	2,250 lbs/ft <sup>2</sup>	2,250 lbs/ft <sup>2</sup>
Centrifugal Force	10 kN	10 kN
Compaction Depth	8 in (20 cm)	8 in (20 cm)
Travel Speed	70 ft/min	70 ft/min
Plate Size	17 x 12 in (43 x 31 cm)	17 x 12 in (43 x 31 cm)
Dimension	35 x 12 x 34 in (90 x 31 x 88 cm)	35 x 12 x 34 in (90 x 31 x 88 cm)

## **3. Operation**

### **3.1 Recommended Fuel**

The engine requires regular grade unleaded gasoline, 87 octane or higher. Use only fresh, clean gasoline. Gasoline containing water or dirt will damage fuel system. Consult engine owner's manual for complete fuel specifications.

### **3.2 Before Starting**

3.2.1 Read and understand safety and operating instructions at beginning of this manual.

3.2.2 Check:

- Oil level in engine
- Fuel level
- Condition of air cleaner
- Tightness of external fasteners
- Condition of fuel lines



### 3.3 TO Start (Fig.1)

3.3.1 Open fuel valve by moving lever to the right (a1).

**Note:** If engine is cold, move choke lever to close position (b1). If engine is hot, set choke to open position (b2).

3.3.2 Turn engine switch to "ON" (e1).

3.3.3 Open throttle by moving it slightly to left (d1).

3.3.4 Pull starter rope (c).

**Note:** If the oil level in the engine is low, the engine will not start. If this happens, add oil to engine. Some engines are equipped with an oil alert light that will come on while pulling the starter rope.

3.3.5 Open choke as engine warms (b2).

3.3.6 Open throttle fully to operate.

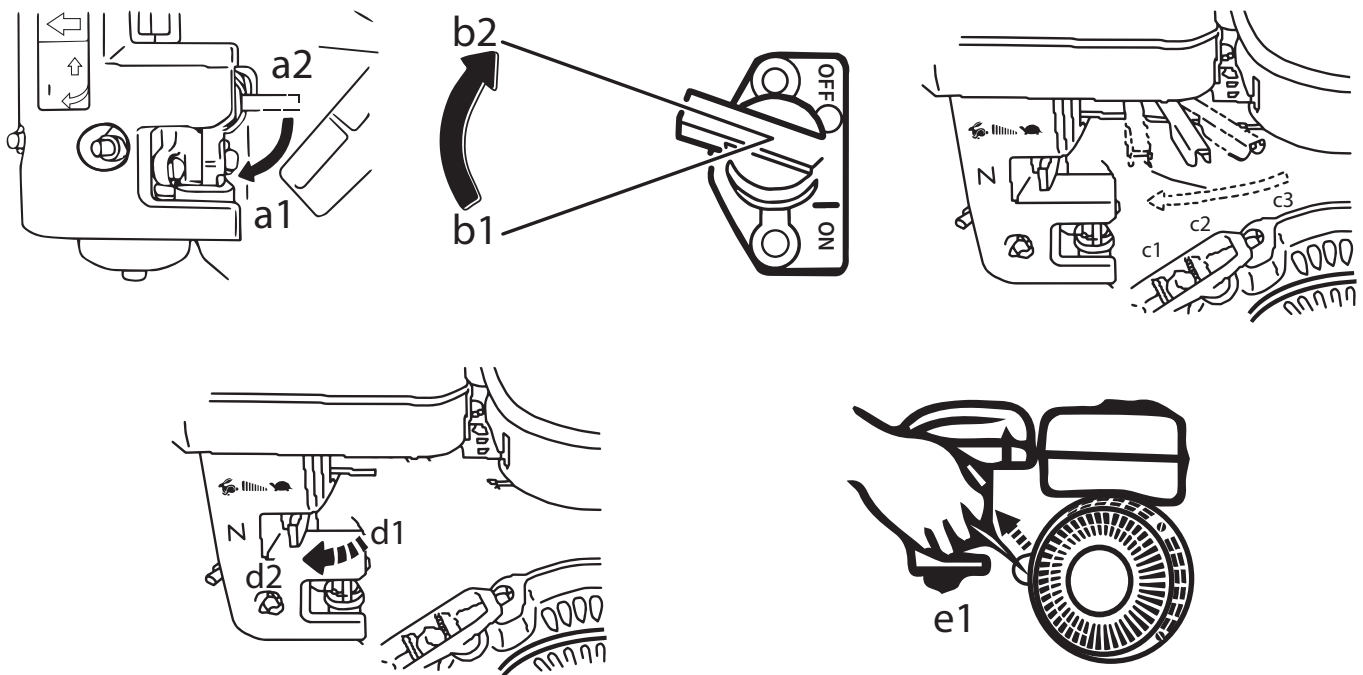

Fig. 1

### 3.4 To Stop

3.4.1 Reduce engine RPM to idle by moving throttle completely to right (d2).

3.4.2 Turn engine switch to "OFF".

3.4.3 Close fuel valve by moving lever to the left (a2).

### 3.5 Application

This plate is designed for compacting loose, granular soils, gravel, and paving stones. It is intended to be used in confined areas and areas next to structures such as walls, curbs, and foundations. Plates equipped with water tanks can be used for compacting asphalt.

### 3.6 Operation (Fig.2)

Run engine at full throttle and allow plate to pull itself along at its normal speed. When operating on an incline it may be necessary to assist plate by pushing it forward slightly. Depending on the material being compacted, three or four passes are recommended to achieve the best compaction.

While a certain amount of moisture in the soil is necessary, excessive moisture may cause soil particles to stick together and prevent good compaction. If soil is extremely wet, allow it to dry somewhat before compacting.

If soil is so dry as to create dust clouds while operating plate, some moisture should be added to the ground material to improve compaction. This will also reduce service to the air filter.

When using the plate on paving stones, attach a pad to the bottom of the plate to prevent chipping or grinding surface of the stones. A special polyurethane pad designed for this purpose is available as an optional accessory.

**CAUTION: DO NOT operate plate on concrete or on extremely hard, dry, compacted surfaces. The plate will jump rather than vibrate and could damage both plate and engine.**

## 4. Maintenance

### 4.1 Periodic Maintenance

The chart below lists basic engine maintenance. Refer to engine manufacturer's Operation Manual for additional information on engine maintenance.

	Daily before starting	After first 20 hours	Every 2 weeks or 50 hours	Every month or 100 hours	Every year or 300 hours
Check fuel level.	●				
Check engine oil level.	●				
Inspect fuel lines.	●				
Inspect air filter. Replace as needed.	●				
Check and tighten external hardware.	●				
Check and adjust drive belt.		●	●		
Clean air cleaner elements.			●		
Inspect shockmounts for damage.			●		
Change engine oil.		●		●	
Clean engine cooling fins.				●	
Clean sediment cup / fuel filter.				●	
Check and clean spark plug.				●	
Check and adjust valve clearance.					●
Change exciter oil.					●

### 4.2 Cleaning Plate

Clean the plate after use to remove dirt, stones, and mud caught under the engine console. If plate is being used in a dusty area, check engine cylinder cooling fins for heavy dirt accumulation. Keep engine cylinder fins clean to prevent engine from overheating.

### 4.3 Drive Belt (Fig.3)

On new machines or after installing a new belt, check belt tension after first 20 hours of operation. Check and adjust belt every 50 hours thereafter.

To change the belt:

4.3.1 Remove the beltguard and remove the four hex nuts (a) holding pulley halves (b) together. Remove outer pulley half and remove belt.

4.3.2 Install new belt on pulley and secure pulley halves together with hex nuts. Adjust tension on belt by adding or removing spacers (c) between pulley halves. The fewer spacers used between pulley halves, the tighter the belt will be. Three spacers with new belts should provide the correct tension. Belt deflection should be 6-10 mm (1/4-3/8"), checked half way between the clutch pulley and the exciter pulley (d). Place unused spacers on outside of pulley.

4.3.3 Replace beltguard.

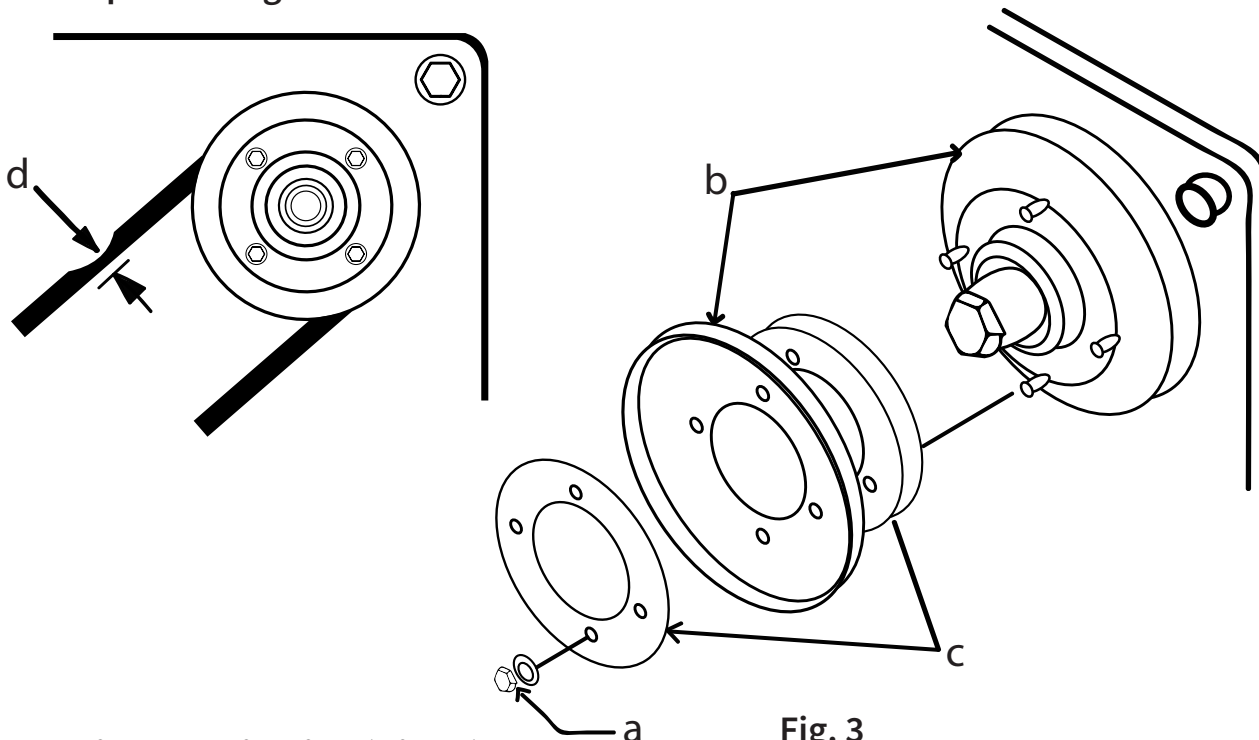

Fig. 3

### 4.4 Exciter Lubrication (Fig. 4)

The exciter assembly is a self-contained, sealed unit. The bearings are lubricated using automatic transmission fluid (see Technical Data for type). Change fluid once every year or 300 hours of operation. When changing fluid, replace O-ring (a).

To change fluid:

4.4.1 Remove beltguard, belt, and hose from water tank.

4.4.2 Remove four screws (b) securing console assembly to baseplate and lift console assembly from baseplate.

4.4.3 Remove end cover (c) from bearing exciter assembly. Outer bearing race will remain with cover.

4.4.4 Tip baseplate up and drain fluid from exciter assembly. Dispose of used fluid in an appropriate manner. Contact local recycling center.

4.4.5 Add 150 ml (5 ounces) of automatic transmission fluid to exciter housing and fasten end cover to exciter. Do not overfill exciter or bearings may overheat.

4.4.6 Set up console assembly to baseplate and install belt, beltguard, and hose to water tank.

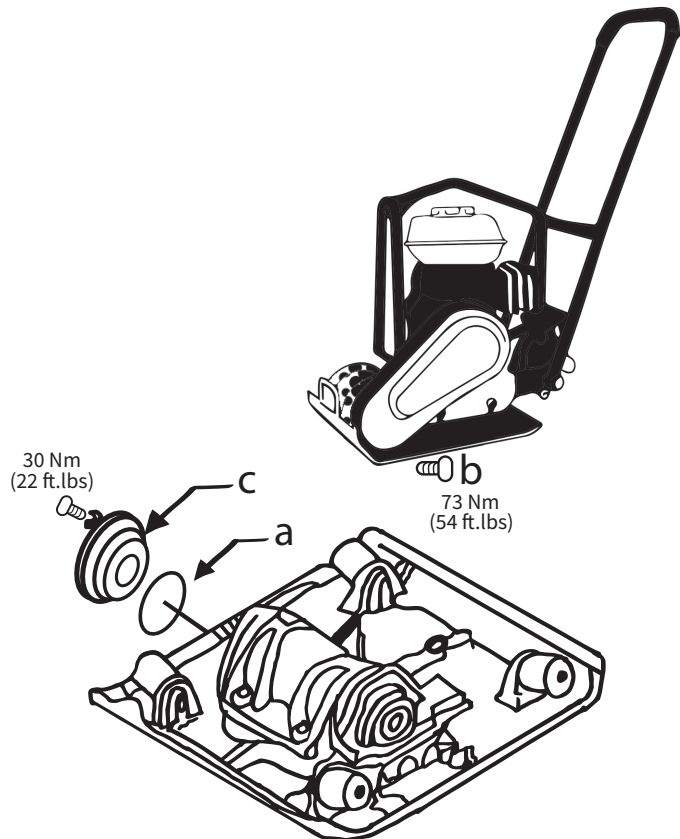

Fig. 4

#### 4.5 Spark Plug (Fig. 5)

Clean or replace spark plug as needed to ensure proper operation. Refer to the engine owner's manual.

The muffler becomes very hot during operation and remains hot for a while after stopping the engine. Do not touch the muffler while it is hot.

**Note: Refer to the Technical Data for the recommended spark plug type and the electrode gap setting (page 6).**

4.5.1 Remove spark plug and inspect it.

4.5.2 Replace plug if the insulator is cracked or chipped.

4.5.3 Clean spark plug electrodes with a wire brush.

4.5.4 Set the electrode gap (a).

4.5.5 Tighten spark plug securely.

**CAUTION: A loose spark plug can become very hot and may cause engine damage.**

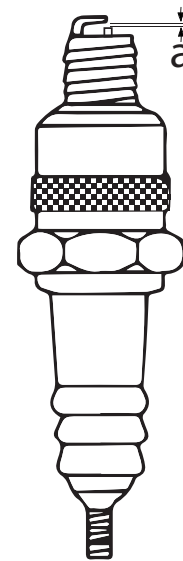

Fig. 5

#### 4.6 Engine Oil (Fig. 6)

4.6.1 Drain oil while the engine is still warm.

4.6.2 Remove the oil fill plug (a) and drain plug (b) to drain oil.

4.6.3 Install drain plug.

4.6.3 Fill the engine crankcase through the oil opening (b), to the upper mark on the dipstick (c). Do not thread in the dipstick to check the level. See Technical Data for oil quantity and type (page 6).

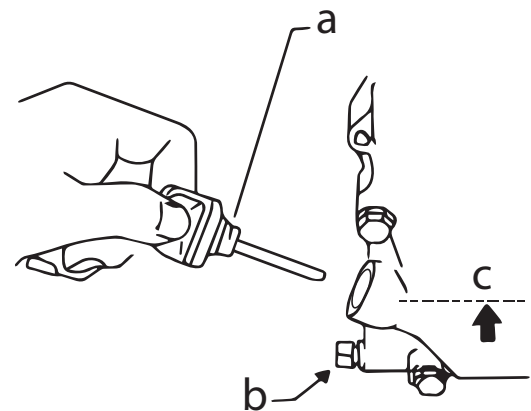

Fig. 6

4.6.4 When the crankcase is full, reinstall the dipstick.

**Note: In the interests of environmental protection, place a plastic sheet and a container under the machine to collect any liquid which drains off. Dispose of this liquid in accordance with environmental protection legislation.**

## 4.7 Air Cleaner (Fig. 7)



NEVER use gasoline or other types of low flash point solvents for cleaning the air cleaner. A fire or explosion could result.



NEVER run engine without air cleaner: Severe engine damage will occur.

The engine is equipped with a dual element air cleaner. Under normal operating conditions, elements should be cleaned once every week. Under severe, dry and dusty conditions, the elements should be maintained daily. Replace an element when saturated with dirt that cannot be removed.

4.7.1 Remove the air cleaner cover (a). Remove both elements and inspect them for holes or tears. Replace damaged elements.

4.7.2 Wash the foam element (b) in a solution of mild detergent and warm water. Rinse it thoroughly in clean water. Allow the element to dry thoroughly.

4.7.3 Tap the paper element (c) lightly to remove excess dirt or blow compressed air through the filter from the inside out. Replace the paper element if it appears heavily soiled.

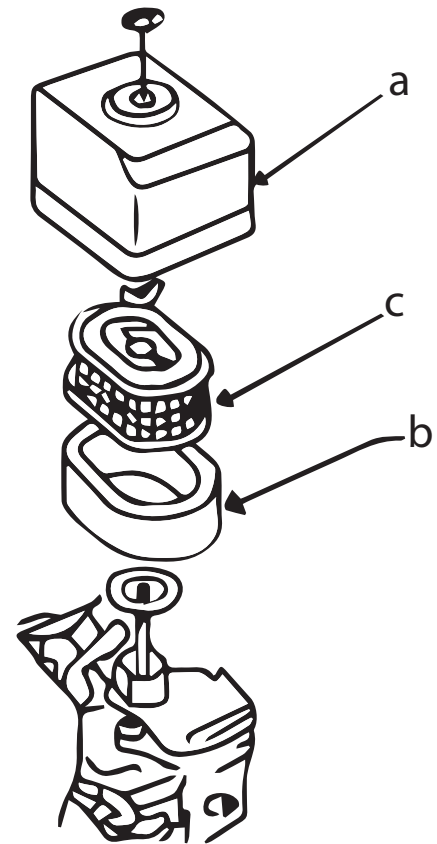

Fig. 7

## 4.8 Cleaning Sediment Cup (Fig. 8)

4.8.1 Turn fuel valve off.

4.8.2 Remove sediment cup (a) and O-ring (b).

4.8.3 Wash both thoroughly in a nonflammable solvent. Dry and reinstall them.

4.8.4 Turn fuel valve on and check for leaks.

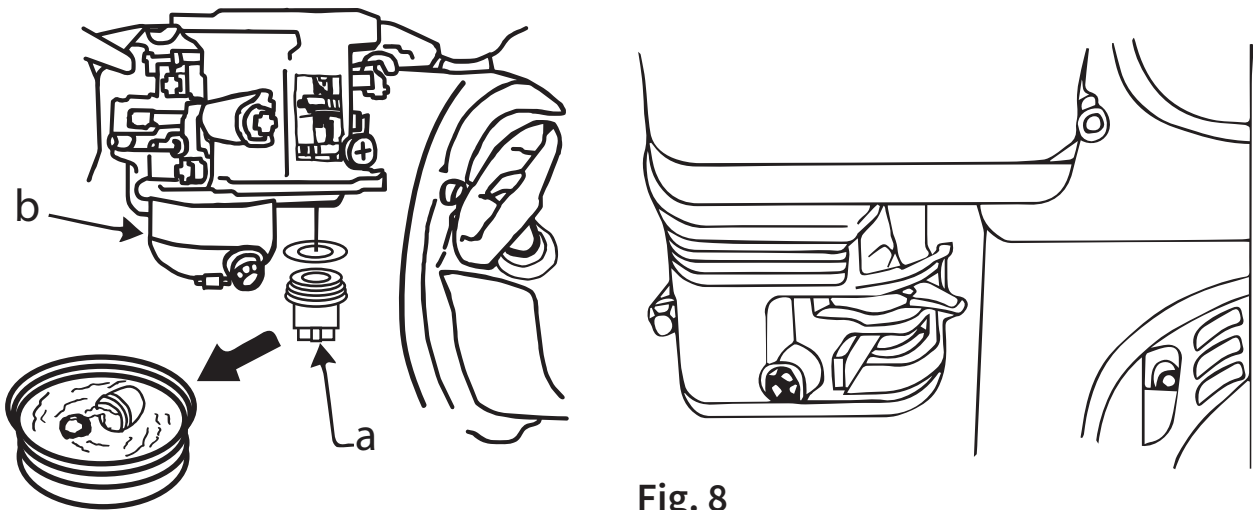

Fig. 8

#### 4.9 Carburetor Adjustment (Fig. 9)

4.9.1 Start the engine and allow it to warm up to operating temperature.

4.9.2 Set the pilot screw (a) 2 turns out. See Note.

4.9.3 With the engine idling, turn the pilot screw (a) in or out to the setting that produces the highest rpm.

4.9.4 After the pilot screw is adjusted, turn the throttle stop screw (b) to obtain the standard idle speed. See Technical Data.

**Note:** On some engines the pilot screw is fitted with a limiter cap (c) to prevent excessive enrichment of the air-fuel mixture in order to comply with emission regulations. The mixture is set at the factory and no adjustment should be necessary. Do not attempt to remove the limiter cap. The limiter cap cannot be removed without breaking the pilot screw.

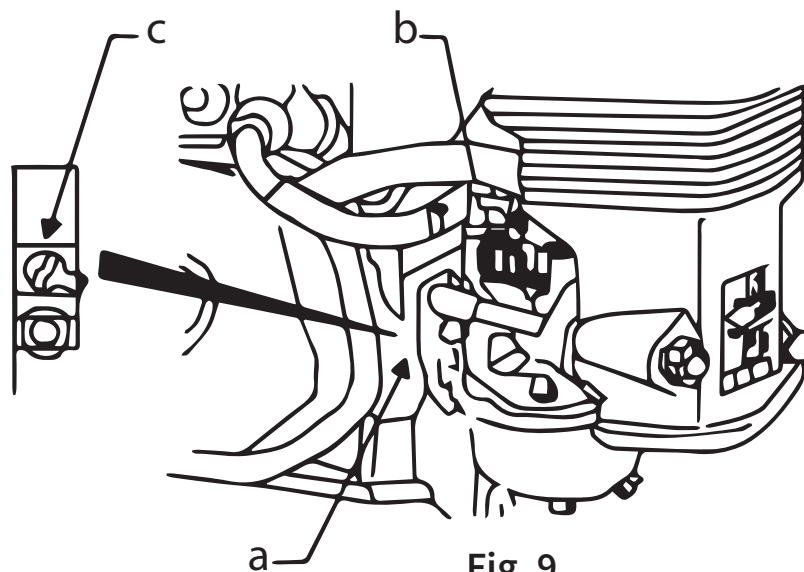

Fig. 9



## 4.10 Troubleshooting

Problem / Symptom	Reason / Remedy
<p>-Plate does not reach full speed.</p> <p>-Poor compaction.</p>	<ul style="list-style-type: none"> <li>• Engine throttle control is not completely open.</li> <li>• Throttle control is not adjusted correctly.</li> <li>• Ground is too wet, plate sticking. Allow soil to dry before compacting.</li> <li>• Drive belt is loose or worn, slipping on pulleys. Adjust or replace belt. Check that the engine mounting bolts are tight.</li> <li>• Exciter bearings binding. Check condition and level of oil in exciter. Add or change oil.</li> <li>• Air filter is clogged with dust, reducing engine performance. Clean or replace air filter.</li> <li>• Engine speed is too low. Check the engine speed with tachometer. Adjust or repair engine to run at correct the speed. Refer to engine manual.</li> </ul>
<p>-Engine running, no vibration.</p>	<ul style="list-style-type: none"> <li>• Engine throttle is not open.</li> <li>• Drive belt is loose or broken. Adjust or replace.</li> <li>• Clutch is damaged. Inspect and replace clutch.</li> <li>• Engine speed is low. Check engine speed.</li> <li>• Too much oil in exciter. Adjust oil to the correct level.</li> </ul>
<p>-Plate jumps or compacts unevenly.</p>	<ul style="list-style-type: none"> <li>• Ground surface is too hard.</li> <li>• Shockmounts loose or damaged.</li> </ul>

## 4.11 Storage

If plate is being stored for more than 30 days:

4.11.1 Remove loose stones and dirt from plate.

4.11.2 Clean engine cylinder cooling fins.

4.11.3 Clean or replace air filter.

4.11.4 Change exciter oil.

4.11.5 Change engine oil and follow procedures described in engine manual for engine storage.

## 4.12 Lifting Machine

See *Technical Data* for the weight of the machine.

### To lift machine manually:

4.12.1 Stop the engine.

4.12.2 Obtain help from a partner and plan the lift.

4.12.3 Grasp the machine by its cage and lifting slot.

4.12.4 Lift the machine.



To reduce risk of back injury while lifting, keep your feet flat on ground and shoulder width apart. Keep your head up and back straight.

### To lift machine mechanically:

**CAUTION:** Before attempting to lift, be sure that all lifting devices can safely handle the weight of the machine. See *Technical Data* (page 7) for the weight of the machine.

Attach hook, harness, or cable to the machine as shown and lift as desired.

**CAUTION:** DO NOT lift the vibroplate by its guide handle. The vibroplate can shift, causing it to fall.

## 4.13 Transporting the Machine



To avoid burns or fire hazards, let the engine cool before transporting the machine or storing indoors.

4.13.1 Turn the fuel valve to the off position and keep the engine level to prevent fuel from spilling.

4.13.2 Tie down the machine on vehicle to prevent the machine from sliding or tipping over.

## 5. Compaction Tips

**5.1 Soil Drop Test:** Soil preparedness refers to the “wetness” of the dirt or soil. Soil needs to be 50% dry and 50% wet, before starting compaction. A simple “hand test” can determine this. Pick up a handful of soil with your hand and squeeze the dirt. Observe whether the soil is powdery or if it breaks apart when dropped. If the soil does break apart, it means that it is too dry. If the soil keeps together in one piece when dropped, it is ready for compaction.

**5.2 Soil Testing:** Testing: The function of this step is to measure the density of an aggregate material to ensure the increase of density when driving out air. At a low moisture content level, there are more soil particles assembling together. In order to determine if the soil is compacted properly, there are several methods.

**5.2.1 Soil Testing:** Test strips are useful to determine the method of compaction and understand how many passes of your plate compactor are needed to achieve the optimum compaction. Every layer of compacted soil meets a specific percentage on the proctor curve. Through soil testing, it is possible to identify optimum moisture. Soil testing measures the soil density compared to the degree of compaction specifications, as well as the effect of the moisture.

A common laboratory method called the Proctor Compaction Test can be used to determine the optimal moisture content for a given soil type. The goal of this method is to understand the soil’s maximum dry density. A second method of soil testing is known as the California Test 216 and is used to find the relative compaction of untreated and treated soils.

Four factors account for optimum compaction including lift thickness, pressure, and soil moisture content. During the compaction process, the soil's moisture adds density and lubricates soil particles, until there is a maximum dry unit weight without voids in the soil. The table below explains the different outcomes and properties of fill materials.

Properties of Different Fill Materials			
	Foundation Support	Permeability	Compaction Difficulty
Gravel	Excellent	Very High	Very Easy
Sand	Good	Medium	Easy
Silt	Poor	Medium Low	Somewhat Difficult
Clay	Moderate	None	Very Difficult

## 5.3 Compaction Terms

**5.3.1 Cohesive soils:** Clays and mixes have a particular particle size of less than .003” or .002” and are typically classified as cohesive soils. This type of soil is primarily used for retaining pond beds and mound fills. These soils are dense due to the strongly bound molecular attraction. Cohesive soils and water will not mix easily, but only once the soils are moist it will feel sticky.



**5.3.2 Granular soils:** These soils have particle sizes of .003” or greater, like sand. Water drains easily through the soils particles of granular soils. The larger the particles, the larger the equipment needed to achieve lower frequencies and higher compaction force. Plate compactors are typically the best option for compacting granular soils - however, depending on the vibration frequency and particle size, reversible plate compactors and double drum rollers may be more appropriate for this type of work.



**5.3.3 Mixed soils:** Sometimes soils can be a mixture of both types, cohesive and granular. Thus choosing the appropriate compaction equipment is more difficult. We recommend testing your equipment to match the best machine to the desired job.



**5.3.4 Static force:** Found in the deadweight of machines, static force applies pressure downward on soil surfaces. As a result, soil particles compress in the topsoil layer.

**5.3.5 Vibratory force:** This force is engine-driven, creating a downward force, in addition to the machine's static weight. Vibrations compress the soil material closer together to increase density.

**5.3.6 Types of compaction:** There are four types of compaction that can be applied to soils or asphalt. Each one takes place using one of the two types of the forces explained above (static or vibratory).

1. Vibration: Periodic motion of particles with rotating weight in opposite directions from a position of equilibrium.
2. Impact: An action of one object coming into contact with another.
3. Kneading: Force is applied by alternating movement in adjacent positions.
4. Pressure: The process of continuous physical force against solid materials.

# SPARE PARTS MANUAL

# JUMPINGJACK

***MODEL: JXPC50H / JXPC50K***

**FORWARD PLATE COMPACTOR**

**(Honda Gasoline Engine)  
(Kohler Gasoline Engine)**

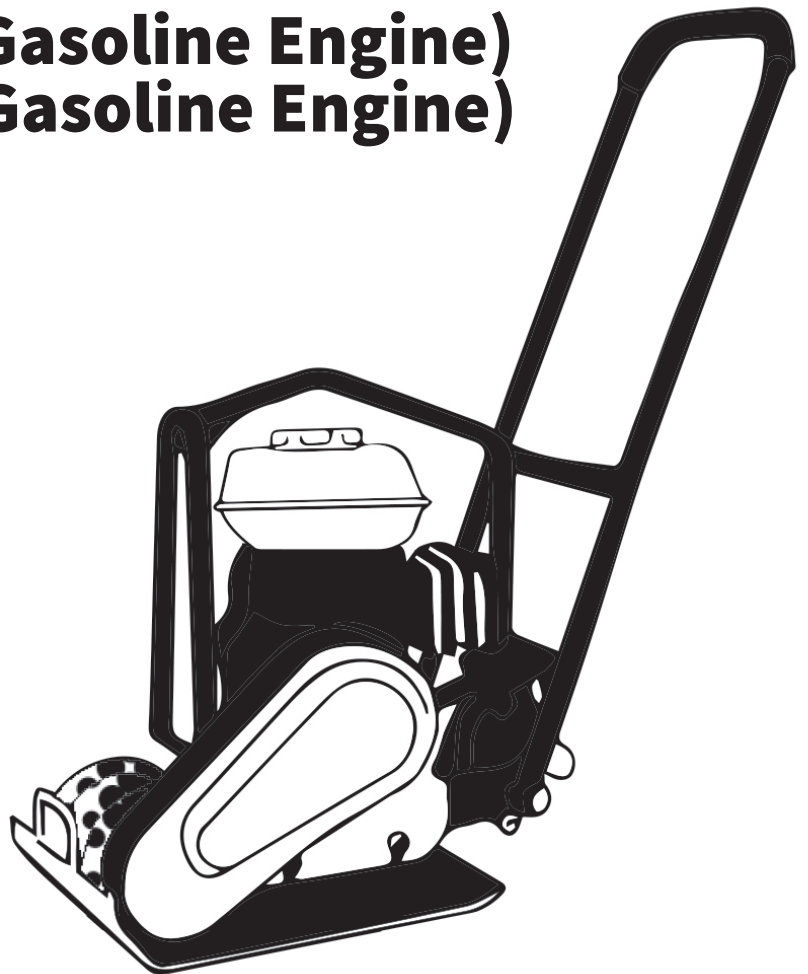

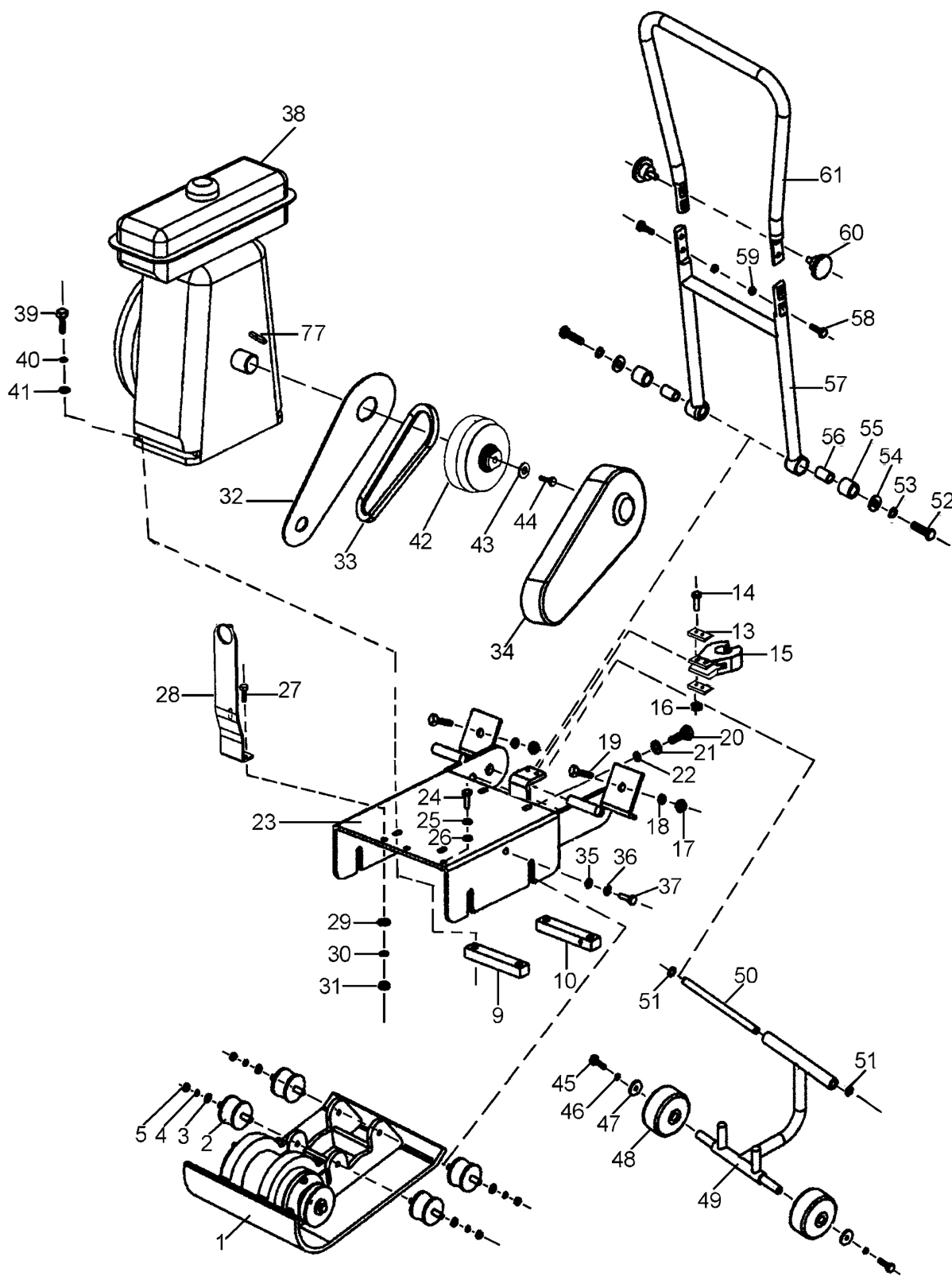

JXPC50

ITEM NO.	PART NO.	DESCRIPTION
1	Z500100001-A	BASE PLATE WITH VIBRATION BOX COVER
2	Z500100002	VIBRATION DAMPER
3	T95-1985-10	WASHER 10
4	T93-1987-10	SPRING WASHER 10
5	T41-1986-M10	NUT M10
9	Z500100003	ENGINE NUT
10	Z500100004	ENGINE NUT
13	Z500100005-A	BRACKET
14	T5782-1986-M4X25	BOLT M4X25
15	Z500100006-A	VIBRATION MOUNT
16	T6170-1986-M4	NUT M4
17	T41-1986-M10	NUT M10
18	T95-1985-10	WASHER 10
19	Z500100007	VIBRATION DAMPER
20	T5782-1986-M8X90	BOLT M8X90
21	T41-1986-M8	NUT M8
22	T93-1987-8	SPRING WASHER 8
23	Z500100008	ENGINE MOUNTING PLATE
24	T5782-1986-M8X15	BOLT M8X15
25	T93-1987-8	SPRING WASHER 8
26	T95-1985-8	WASHER 8
27	T5782-1986-M8X25	BOLT M8X25
28	Z500100009	LIFTING HOOK
29	T95-1985-8	WASHER 8
30	T93-1987-8	SPRING WASHER 8
31	T41-1986-M8	NUT M8
32	Z500100010	INSIDE BELT COVER
33	011544	V-BELT
34	Z500100011	BELT COVER
35	T95-1985-8	WASHER 8
36	T93-1987-8	SPRING WASHER 8
37	T5782-1986-M8X15	BOLT M8X15
38	Z500100012	CHINESE PETROL ENGINE
39	T5782-1986-M8X50	BOLT M8X50
40	T93-1987-8	SPRING WASHER 8
41	T95-1985-8	WASHER 8
42	Z500100013	PULLEY ASSY.
43	T5287-1985-8	WASHER 8
44	T5782-1986-M8X25	BOLT M8X25
45	T5782-1986-M8X20	BOLT M8X20



ITEM NO.	PART NO.	DESCRIPTION
46	T5287-1985-8	WASHER 8
47	T93-1987-8	SPRING WASHER 8
48	Z500100014	WHEEL
49	Z500100015	WHEEL SHAFT
50	Z500100016	SPINDLE
51	T894.2-1986-13	RETAINING RING 13
52	T5782-1986-M12X6	BOLT M12X60
53	T93-1987-12	SPRING WASHER 12
54	T95-1985-12	WASHER 12
55	Z500100017	RUBBER MOUNT
56	Z500100018	COLLAR
57	Z500100019	HANDLE-DOWN
58	T5782-1986-M10X3	BOLT M10X35
59	T41-1986-M10	NUT M10
60	Z500100020	KNOB
61	Z500100021	HANDLE-UPPER
77	Z500100028	KEY

ITEM NO.	PART NO.	DESCRIPTION
62	T5782-1986-M6X18	BOLT M6X18
63	T93-1987-6	SPRING WASHER 6
64	T95-1985-6	WASHER 6
65	Z500100022	BEARING COVER
66	Z500100023	O-RING
67	T276-6208	BEARING 6208
68	Z500100024	ECCENTRIC ROTATOR
69	T1096-1979-C8X15	KEY
72	Z500100026	BEARING COVER
73	Z500100027	PULLEY
74	T5287-1985-8	WASHER 8
75	T93-1987-8	SPRING WASHER 8
76	T5782-1986-M8X25	BOLT M8X25

