

Automatic fuel oil de-aerator comparison

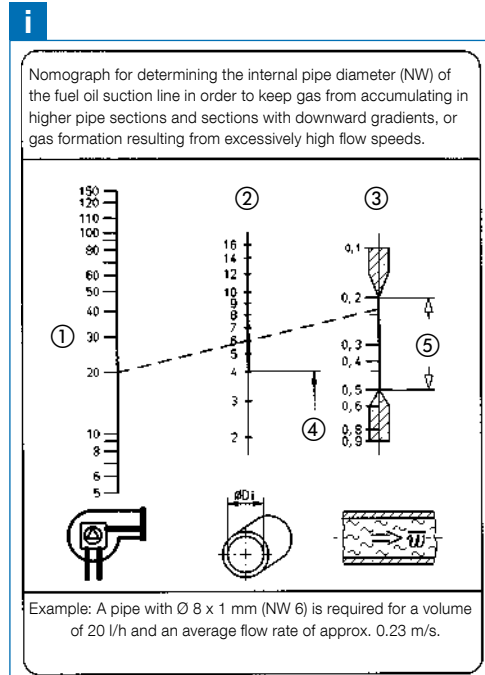

	Automatic fuel oil de-aerators		Automatic fuel oil de-aerators with filter		
Version	Flow-Control 3/K	Flow-Control 3/K HT	FloCo-Top-1K	FloCo-Top-2 KM Si	FloCo-Top-2 Optimum MC-18
Catalogue page	See page 140.	See page 141.	See page 145.	See page 142.	See page 144.
Application area	Single-line systems with return line				
Media	<ul style="list-style-type: none"> Fuel oil EL Diesel fuel Biofuel or bio-diesel with up to 20 % FAME 	<ul style="list-style-type: none"> Fuel oil EL Diesel fuel Biofuel or bio-diesel with up to 100 % FAME Vegetable oils (colza oil) 	<ul style="list-style-type: none"> Fuel oil EL Diesel fuel Biofuel or bio-diesel with up to 20 % FAME 	<ul style="list-style-type: none"> Fuel oil EL Diesel fuel Biofuel or biodiesel with up to 20 % FAME 	
Function	Continuous de-aeration		Continuous de-aeration and oil filtration	Continuous de-aeration and multiple oil filtration	
Filters	-	-	Sintered plastic filter	Sintered plastic filter	Opticlean ultra-fine filters
Vacuum gauge	-	-	-	-0.7/+0.9 bar	
Approval for construction products	Conformity certificate (ÜHP) as per EN 12514-2				

6



Our tip

Only installation by expert companies certified according to the applicable regulations ensures optimum operation of the automatic de-aerators. For optimum combustion, longer nozzle and filter service life and reliable function, the expert determines the following prior to installation and compares the values with the nomograph:

- Oil throughput per hour at burner nozzle
- Inside diameter of the (installed) oil suction line
- Vacuum (overpressure) in the oil carrying pipe upstream of the burner

The oil suction line is often too large. The flow rates of 0.2/0.5 m/s, required according to DIN 4755-2, are often not reached in systems converted from dual-line to single-line mode. The nomograph shows the proper values for sizing the suction line.

- ① Nozzle consumption l/h
- ② Inside diameter of the suction line in mm
- ③ Flow rate of the fuel oil in m/s
- ④ < $\varnothing 4$ not advisable
- ⑤ Recommended range as per DIN 4755-T2

Automatic fuel oil de-aerator

FloCo-Top-1K TÜV-tested

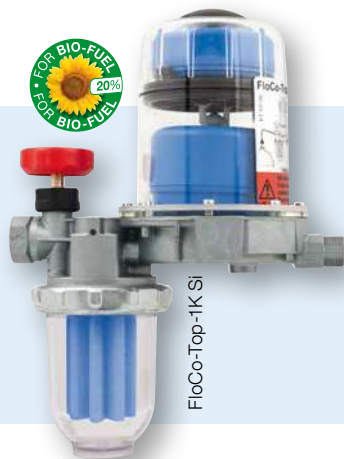

- Fuel oil de-aerator, filter and shut-off valve in a single, compact unit.
- Safety system keeps oil foam from escaping



Application For single-line systems with return line in oil fired systems for continuous de-aeration. Suitable for the following media: fuel oil EL (DIN 51603-1) and diesel fuel (EN 590) as well as biofuel and biodiesel with max. 20 % FAME. Also for use in flood hazard areas.

Description Automatic fuel oil de-aerator, safety version, with integrated filter and shut-off valve. Metal zinc die cast with G $\frac{3}{8}$ connection thread at the tank end and male G $\frac{3}{8}$ connection threads at the burner end with female cone at the burner end to connect the burner hoses. The de-aerator hood is made of transparent plastic and features two separate float chambers. The lower float chamber contains the operating float; the upper float chamber contains the safety float. The upper safety float chamber keeps oil from escaping through the vent opening. In addition, it is possible to detect malfunctions in the de-aeration system. Watertight up to 10 m water column.

Technical specifications

Burner connection

G $\frac{3}{8}$ male with 60° cone for burner hoses

Tank connection

G $\frac{3}{8}$ female

Nozzle capacity

Max. 100 l/h

Return flow

Max. 120 l/h

Separating capacity air/gas

Approx. 4 l/h

Mounting position

Float housing vertical to the top

Operating temperature range

Medium: Max. 60 °C

Ambient: Max. 60 °C

Operating overpressure

Max. 0.7 bar

corresponds to static oil column of approx. 8 m

Test pressure

6 bar

Dimensions

W x H x D: 165 x 221 x 99 mm

Material

Housing: Zinc die cast

De-aerator hood: Transparent plastic

Filter cup: Transparent plastic

Approval

TÜV-tested (S 133 2013 E2)

Approval for construction products

Conformity certificate (ÜHP)

as per EN 12514-2

Scope of delivery

- Fuel oil de-aerators
- Bracket with mounting material
- Cover for connection of the vent hose

DG: G, PG: 1	De-aerator hood	Filters	Filter cup	Part no.	Price €
FloCo-Top-1K Si	Plastic	Sintered plastic sieve short, 50 µm	Short	69960	
Spare part					
Bracket FloCo-Top-1 series	-	-	-	69946	