



Data Sheet

3M Scotchlok™

Self-Stripping Electrical Tap Connectors TTT-R, TTT-B, TTT-Y



Application

Use Scotchlok™ Tap Connectors 952, 952, or 953 to electrically tap into a wire in mid-span without cutting or stripping the wire. Connector then mates with a .250" (6.35 mm) male tab, making a reusable quick-connect wiring termination.

Wire Ranges

(See table for specific connector wire range) 22-12 AWG solid or stranded tinned or untinned (.5-3.0 mm sol. or str.) copper conductors. For use with common thermoplastic insulated wires such as: T, TW, TF, TFF, TFFN, THHN, AWM, TEW, SAE-GPT with a maximum wire insulation diameter of .150 inches (3.8 mm). Maximum recommended connector current:

22 AWG - 3.0 Amps	20 AWG - 4.0 Amps
18 AWG - 7.5 Amps	16 AWG - 10 Amps
14 AWG - 15 Amps	12 AWG - 20 Amps

Conn.#	Color	Wire Range (AWG-mm²)	Weight lb./gm
TTT-R	RED	22-18 (0,5-0,8)	.0023 (1,04)
TTT-B	BLUE	18-14 (0,8-2,0)	.0023 (1,04)
TTT-Y	YELLOW	12 (3,0)	.0022 (1,00)

Construction

Element - Tin plated brass, .03 in. (.8 mm) thick
 Insulator - Flame retardant nylon,
 See table for color

Recommended Installation Tools

3M™ Crimping Tool No. E-9BM
 Mechanics (slip joint) Pliers

Installation Instructions

⚠ WARNING

Turn power off before installing or removing terminal. All electrical work should be done according to appropriate electrical codes.

1. Do not strip run wire.
2. Place run wire in open channel.
3. Fold connector body until element contacts wire.
4. Crimp connector closed with pliers.
5. Slide completed T-Tap onto male tab.

Note: Tab not included. Suitable for field or factory installation. For field wiring, a suitable UL Recognized strain relief device is required.

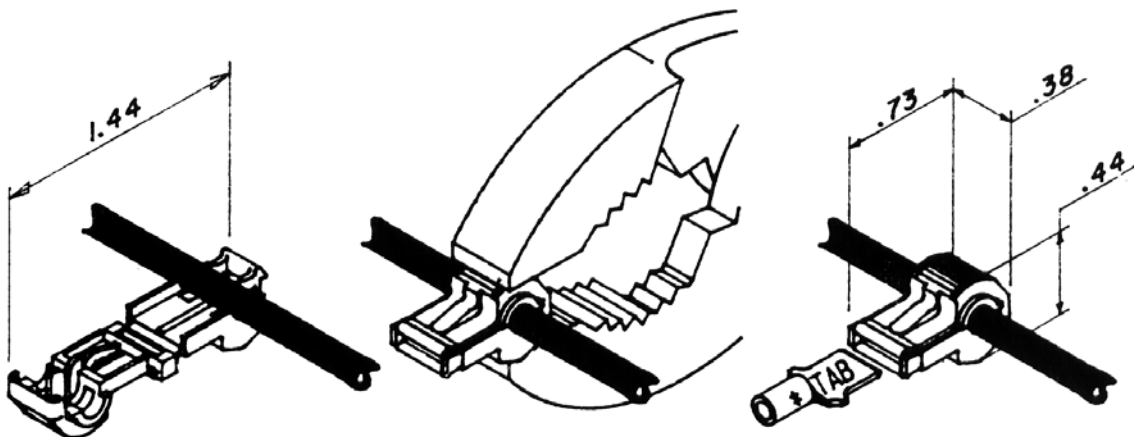

Regulatory Agencies

UL Listed - Tested per UL Standard 486C
UL file No. E23438

Voltage rated at 600 volts maximum, building wire:
1000 volts maximum, signs and fixtures.
Temperature rated at 105°C (221°F).

Note: UL Listed for AWG only.

CSA Certified-CSA Standard C22.2 No. 0,
188-M1983

CSA File No. LR15503

Operating Temperature: 105°C (221°F)

Voltage Rating: 600 volts max. building wire
1000 volts max. signs and luminaires.

Flammability Rating: C22.2 No. 0.6 V-2

Engineering Specification

Self-Stripping T-Tap Female Quick-Slide connector (as manufactured by 3M) capable of connecting to an insulated, solid or stranded copper wire, in mid-span, without cutting or stripping the wire; and of connecting to a .250 in. x.032 in. Male Tab such as a MNG14-250DMI, in a separable, reusable manner, forming a Quick Connect Wiring Termination.

The electrical connecting element shall be tin plated brass: the insulator body shall be molded nylon, color coded to run wire size: Part Nos. 951 Red (22-18 AWG), 952 Blue (18-14 AWG), 953 yellow (12 AWG). Connector shall be UL Listed and CSA Certified for 600 volts maximum, building wire: 1000 volts maximum, signs and fixtures, and temperature rated 105°C (221°F) maximum.

Federal Specification W-S-610D
"Commercial Packaging"

Type	Class	Kind	Style
II	I	Cu	F

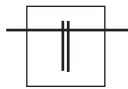

Tap Connector

3M and Scotchlok are trademarks of 3M Company.



is a trademark of Underwriters Laboratories.



is a trademark of Canadian Standards Association.

IMPORTANT NOTICE

Before using this product, you must evaluate it and determine if it is suitable for your intended application. You assume all risks and liability associated with such use.

Warranty; Limited Remedy; Limited Liability. This product will be free from defects in material and manufacture as of the date of purchase. **3M MAKES NO OTHER WARRANTIES INCLUDING, BUT NOT LIMITED TO, ANY IMPLIED WARRANTY OF MERCHANTABILITY OR FITNESS FOR A PARTICULAR PURPOSE.** If this product is defective within the warranty period stated above, your exclusive remedy shall be, at 3M's option, to replace or repair the 3M product or refund the purchase price of the 3M product. **Except where prohibited by law, 3M will not be liable for any loss or damage arising from this 3M product, whether direct, indirect, special, incidental or consequential regardless of the legal theory asserted.**