

DASH NO. RANGE	"D" DIA RANGE	"E" DIMENSION		"G"	"R"	"T" GAUGE	
		ALUMINUM	STEEL			ALUM	STEEL
-04SS THRU -08SS	1/4" THRU 1/2"	"D"/2 + .405	"D"/2 + .405	.062/.078	.062	.032	.032
-10SS THRU -12SS	5/8" THRU 3/4"	"D"/2 + .471	"D"/2 + .468	.062/.078	.109	.050	.032
-14SS THRU -16SS	7/8" THRU 1"	"D"/2 + .471	"D"/2 + .452	.062/.078	.109	.050	.032
-18SS THRU -30SS	1 1/8" THRU 1 7/8"	"D"/2 + .500	"D"/2 + .468	.094/.125	.125	.063	.032
-32SS THRU -48SS	2" THRU 3"	"D"/2 + .500	"D"/2 + .476	.125/.156	.125	.063	.040

MATERIAL CODES:

"SS" 304/321 STAINLESS STEEL PER TLC-MT-STA-001/STA-005. FINISH: NONE.

CUSHION: "G" GENERAL PURPOSE EPDM PER TLC-CM-ETH-001. COLOR: BLACK

REV.	CHANGE	DATE	BY	CHK'D	APPR
X	SEE DRAWING CHANGE RECORD ON FILE.	08/05/09	SMJ	JV	JV

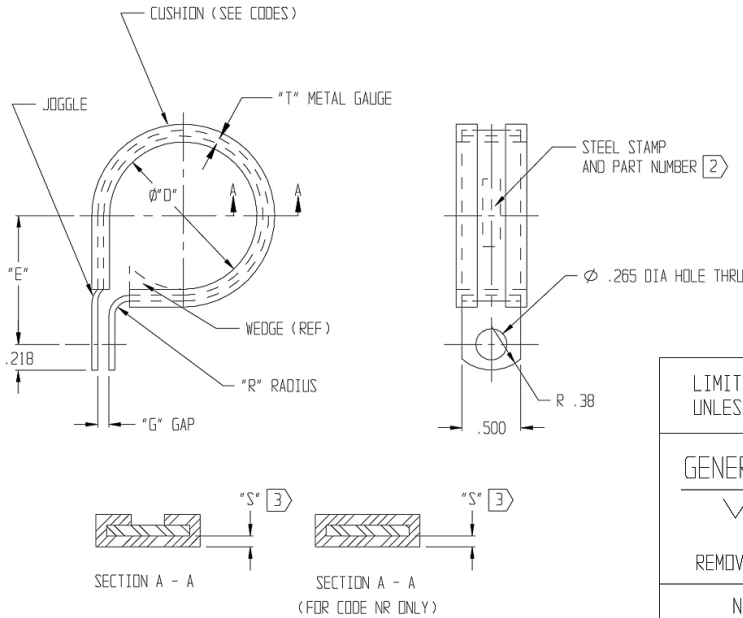

LIMITS ON DIMENSIONS UNLESS OTHERWISE SPECIFIED	ANGULAR	±
	DECIMAL	.XX ± .03 .XXX ± .015

GENERAL MACHINE FINISHES EXCEPT AS NOTED:
 PER ASME-Y14.5M

REMOVE ALL BURRS AND BREAK SHARP EDGES .010 MAX

NOTED	NOTED	ACT NIGHT
HEAT TREAT	FINISH	CALC NIGHT

		NOTED		NOTED		
REQ' MNTS PER ASSEMBLY	PART NUMBER	QTY REQ'D	MATERIAL AND/OR PART NAME	MATERIAL SPECIFICATIONS		
	1-800-942-2292			KEL	LJS	KWE
				09/30/55	07/24/06	07/24/06
				DRAWN	CHECKED	ENG' RING
				SCALE = NONE		
	CLAMP, LOOP TYPE SUPPORT, CUSHIONED 1/4" MOUNTING BOLT, LIGHT/MEDIUM DUTY			TLC-*		
No. REQ'D	NEXT ASSEMBLY	PART AND/OR ASSEMBLY NAME		PART NUMBER		